

Design of a Portable Test Facility for the ATLAS Tile Calorimeter Front-End Electronics Verification

H.Y. Kim*, H. Åkerstedt, F. Carrio, P. Moreno, T. Masike, R. Reed, C. Sandrock,
V. Schettino, A. Shalyugin, C. Solans, J. Souza, R. Suter, G. Usai, A. Valero

on behalf of the ATLAS Tile Calorimeter System

Abstract—The stand-alone test-bench deployed in the past for the verification of the Tile Calorimeter (TileCal) front-end electronics is reaching the end of its life cycle. A new version of the test-bench has been designed and built with the aim of improving the portability and exploring new technologies for future versions of the TileCal read-out electronics. An FPGA-based motherboard with an embedded hardware processor and a few dedicated daughter-boards are used to implement all the functionalities needed to interface with the front-end electronics (TTC, G-Link, CANbus) and to verify the functionalities using electronic signals and LED pulses. The new device is portable and performs well, allowing validation of the data transmission under realistic conditions. We discuss the system implementation and all the tests required to gain full confidence in the operation of the front-end electronics of the TileCal in the ATLAS detector.

Index Terms—LHC, ATLAS, TileCal, Maintenance, ADC

I. INTRODUCTION

THE Large Hadron Collider (LHC) [1] shown in Figure 1 is a particle accelerator which started operation in 2008 and was designed to provide proton-proton collisions at a center-of-mass energy of 14 TeV at CERN. It lies in a tunnel of 27 km in circumference and 100 m beneath the France-Switzerland border near Geneva, Switzerland. For the maintenance of the LHC and its experiments, the first Long Shutdown (LS1) started in 2013 and will continue through 2014.

The ATLAS experiment [2] shown in Figure 2 is one of the general purpose detectors of the LHC. Its physical dimension is 45 m long, 25 m in diameter, and it weighs 7,000 tons. Over 3000 collaborators from 175 institutions in 38 countries participate in this experiment. The main components of the detector are the muon spectrometer, the inner detector, the calorimeters, and the magnet system. Along with the CMS



Fig. 1. The LHC lies beneath the French-Swiss border. Its circumference is 27 km and its designed collision energy is up to $\sqrt{s} = 14 \text{ TeV}$

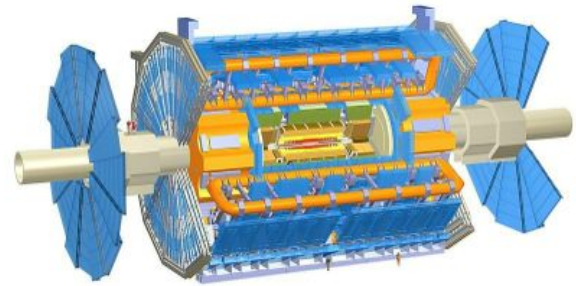

Fig. 2. The drawing of the ATLAS detector. It is mainly composed of an inner detector, EM and Hadronic calorimeters, a magnet system, and a muon spectrometer.

experiment, ATLAS contributed to the discovery of the Higgs boson in July 2012 [3].

The ATLAS calorimeter system [2] shown in Figure 3 is composed of an ElectroMagnetic (EM) calorimeter and three Hadronic Calorimeters (one of which is called TileCal). TileCal consists of plastic scintillating tiles interleaved between iron plates. It covers the pseudo-rapidity ($|\eta|$) range from -1.7 to 1.7, and is divided into three barrels: two extended barrels (EBC and EBA) and one central long barrel (LBA and LBC). Sixty-four modules (super-drawers) cover the entire azimuthal range of each barrel and are radially segmented into three layers.

When charged particles pass through the plastic scintillating tiles, photons are produced. Those photons are conveyed to the Photo Multiplier Tubes (PMTs) located in the front-end electronics drawers of TileCal at the outermost region. Groups of tiles that define calorimetric cells are redundantly read out on each side of the module by two PMTs.

The complete set of electronics is checked by following a certification procedure. Specific tests are designed to verify the

H.Y. Kim* is the corresponding author.

H.Y. Kim*, G. Usai, 502 Yates St. Science Hall Rm 108, Box 19059, Arlington, TX 76019, U.S.A. (e-mail: hee.yeun.kim@cern.ch).

H. Åkerstedt, The Department of Physics, Stockholm University, SE-106 91 Stockholm, Sweden

F. Carrio, A. Valero, IFIC, Catedrático Jos e Beltrán s/n, Paterna, Spa
P. Moreno, T. Masike, R. Reed, C. Sandrock, R. Suter, High Energy Physics Group, University of Witwatersrand, 1 Jan Smuts Ave, Johannesburg, South Africa

V. Schettino, J. Souza, UFJF, Rua Jos e Lourenço Kelmer s/n - Campus Universitário - Bairro São Pedro, Juiz de Fora - MG, 36036-900, Brazil

A. Shalyugin, JINR, Joliot-Curie 6, 141980 Dubna, Moscow region, Russia
C. Solans, CERN, Geneva 23, CH-1211 Switzerland

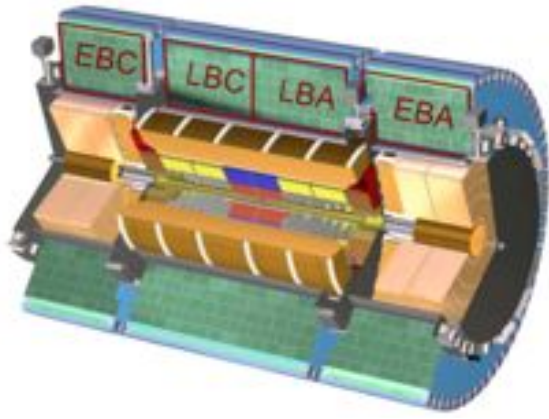

Fig. 3. The ATLAS TileCal system covers the region $-1.7 < |\eta| < 1.7$. There are 3 barrels, two extended barrels and one long barrel, that have 64 modules covering the entire azimuthal range of each barrel.

correct functionality of the various front-end elements. Any under-performing component is replaced and complementary reinforcements are made on the connectors. The certification is assessed twice: first, before any manipulation but after the super-drawer is extracted, and second, once the super-drawer is back into its final position. This first iteration is important because it allows the cross check of any problems identified during data acquisition before any hardware manipulation is made. The certification of the repairs is assessed through the Mobile Data Integrity Check (MobiDICK) system [4].

II. MOBIDICK

MobiDICK-4 shown in Figure 4 is a new generation of the portable test-bench for full certification and quality assurance of super-drawers in TileCal during maintenance periods. It replaces the obsolete VME technology with modern FPGA devices which control both commercial devices and custom components to provide the functionality required to certify a super-drawer. The new system is expected to increase the portability and reliability, provide a shorter turnaround time, and improve the overall test-bench coverage [5]. The hardware is interfaced through a GUI called Willy, which is implemented in C++. The GUI is adapted from a previous version of the system to reduce development time and ease the transition for maintenance personnel.

A. Hardware

Figure 5 show how the hardware components of the MobiDICK-4 are organized. The Xilinx ML507 evaluation board [6] is responsible for the overall control of the system and performs the data analysis processing. It is equipped with a Virtex-5 FX70T, including a PowerPC at 440 MHz, a Small Format Plug-gable (SFP) optical transceiver, an Ethernet port, and a compact flash drive slot. The ADC board digitizes the analog signal from the super-drawer. It has two ADS5271 12 bit ADC chips from Texas Instruments with a total of 16 ADC channels (8 channels on each ADC). Its sampling rate is 40 Msp/s and it has a serial LVDS output to the main board. A High Voltage board and a LED driver board are

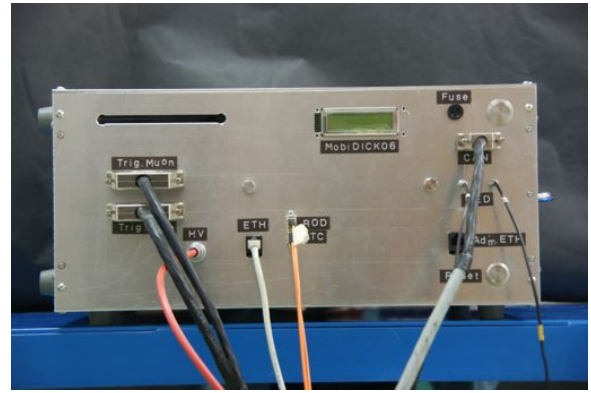

Fig. 4. MobiDICK-4 (Mobile Drawer Integrity ChecKing 4) system, the new generation of portable test-bench to certify the super-drawers' front-end electronics.

available for tests under realistic conditions. The HV board feeds PMTs with -830 V through a TTL input interface and the LED board is designed to generate 20 ns wide pulses to drive two LEDs through a TTL output interface. CANbus is used for the communication between MobiDICK-4 and the super-drawer's HV and integrator systems.

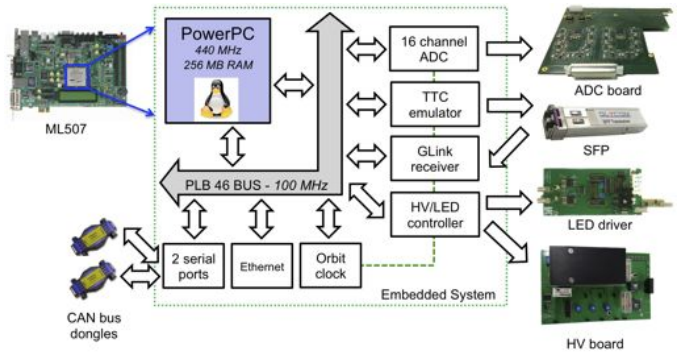

Fig. 5. Block diagram of the embedded system for the MobiDICK-4 system.

B. Software

MobiDICK-4 is based on a software system inherited from the previous version. It implements a client-server architecture between the ML507 (server) and a laptop (client). Willy allows users to manage the different tests needed for the certification. After the server extracts and processes data from the control hardware, it sends results back to Willy. Users are able to monitor the results in real-time and collect information through the GUI.

C. Portable design

The previous MobiDICK system was limited due to its poor maneuverability and its large dimensions. The increased mobility of the new MobiDICK was a considerable improvement. It is much better adapted to the maintenance conditions inside the ATLAS detector. Its volume is reduced to a portable dimension (35 cm x 40 cm x 20 cm) and a light custom aluminum box was used to reduce the weight. Overall, the

system weighs ~ 4 kg, which is a large reduction from the former weight is ~ 20 kg. A forced air cooling system is enclosed in the box to avoid heat-induced system failures.

III. PERFORMANCE AND CHARACTERIZATION SYSTEM TESTS

MobiDICK is implemented as real-time computing hardware designed for intense maintenance campaign periods. It is composed of commercial hardware and off-the-shelf components including the FPGA board itself. The implementation of new tests does not require knowledge of VHDL for firmware programming, as they can be implemented in C++ in the client. With this tool we extended the lifetime of the test-bench by 10 years and improved the quality assurance of the maintenance.

A. Improved Real-time processing

The new MobiDICK's Power PC embedded motherboard supplies the computing power to handle the data in real-time with a combination of VHDL modules and the C++ based data processing algorithms. The FPGA processes an large amount of data and selects it with the 100 kHz trigger rate. This data can be updated in real time and accessed in C++.

B. New Functionality

While existing functionality tests are the basis for the certification process, the new MobiDICK system adds a new stuck bit test [7]. A stuck bit test as shown in Figure 6 is implemented to detect upset bits in the samples caused by failures in the front-end digitizer boards. In this test, a set of pulses produced from the variation of 3 parameters (amplitude, time, and pedestal) are used to scan over all the 10 bits of the ADC. The results are displayed in the GUI window. Although the failure rate is low, it affects the data quality. Thus, this new functionality test was demanded and was implemented in the system.



Fig. 6. The stuck bit test is a new functionality test which detects upset bits that can cause failures in the digitizing process.

C. Characterization of the ADC board

The ADC board converts analog signals to digital sample data to test the analog trigger output. It plays a key role in the data analysis of the performance of the super drawer front-end. A Flat Filter method that is the integral of the signal area is implemented in the software to reconstruct the signals from the super-drawer. The comparison with an Optimal Filter [8] which is our best technique for pulse amplitude estimation is shown in Figure 7 and Figure 8. In Figure 7, the linearity of the reconstructed energy as a function of different charges is very good for both Flat and Optimal Filters. The difference between these two methods are not significant.

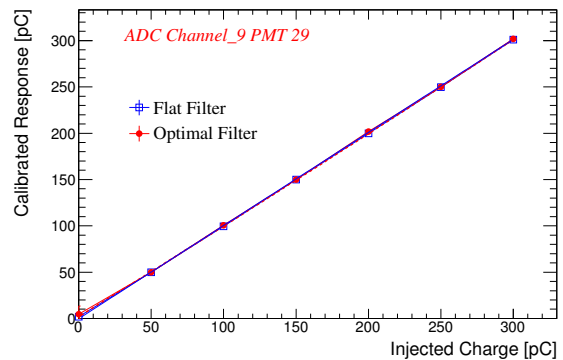

Fig. 7. An example of calibrated response as a function of injected charge reconstructed by the ADC board is shown.

The ADC channel responses for a given charge are overall uniform. The uniformity of the ADC channels is shown in Figure 8. The top plot is the reconstructed response versus channels and the bottom is the deviation from the mean. Both Flat Filter and Optimal Filter responses agree as seen in Figure 8. The ADC system has two ADCs to digitize all signals. Channels 0 to 7 are controlled by one ADC while the other ADC monitors channels 8 to 15. The difference between the two ADCs is found to be a negligible 0.1 %.

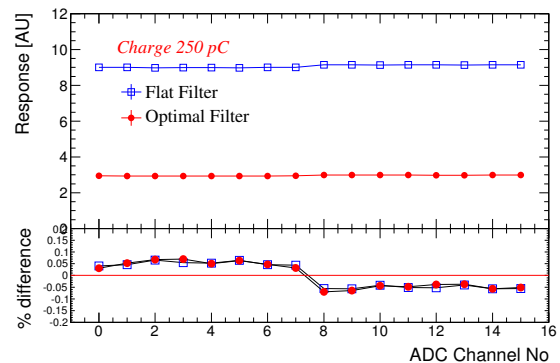

Fig. 8. Uniformity of the channels in the ADC board reconstructing at the charge of 250 pC.

Therefore, we conclude that the performance of the implemented reconstruction algorithm is good. Differences between the ADCs can be further improved by the inter-calibration.

D. Precision test of analog signal from the super-drawer with the ADC board

The analog output of the super-drawer can be monitored with the system acting as a digital scope. Up to 128 samples can be stored at a time and are obtained with a sampling rate of 40 Msps. MobiDICK-4 can provide pulse shape measurements from both tower and muon outputs of the super drawer were performed by through sampling the pulses at the certain injected charge. As expected, the muon outputs have a slightly wider pulse width, which is compatible with previous measurements [8].

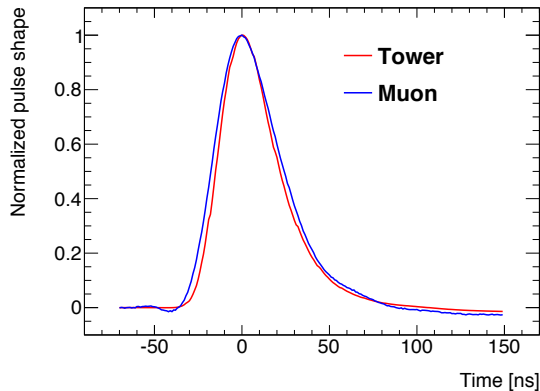

Fig. 9. Charge injection pulse shape for tower trigger and muon signal outputs.

IV. CONCLUSIONS

The MobiDICK system has been upgraded to improve the certification and verification of the performance of the front-end electronics of the TileCal. The MobiDICK hardware has been replaced with newer technologies and the software has been optimized to determine the characteristics of the super-drawers more efficiently. Moreover, the physical features such as weight, mobility and size are much better suited for the underground work environment. The implemented analysis method was verified to give correct results. Since all obsolete part have been replaced, it is clear that MobiDICK-4 has extended the lifetime of the system and when these part become obsolete they are easily replaced further extending the life of the system. MobiDICK-4 is currently being used at the actual scene of the maintenance campaign of the ATLAS experiment.

REFERENCES

- [1] L. Evans et al., *LHC Machine*, J. Instrum., vol. 3, p. S08001, 2008.
- [2] The ATLAS Collaboration, *The ATLAS experiment at the CERN Large Hadron Collider*, J. Instrum., vol. 3, p. S08003, 2008.
- [3] The ATLAS Collaboration, *Observation of a new particle in the search for the Standard Model Higgs boson with the ATLAS detector at the LHC*, Phys.Lett. B716 (2012) 1-29
- [4] R. Bonnefoy et al., *MobiDICK: a mobile test bench for the TileCal Super-Drawers*, ATL-TILECAL-2004-003, CERN, 2003
- [5] F. Carrio et al., *Design of an FPGA-based embedded system for the ATLAS Tile Calorimeter front-end electronics test-bench*, Topical Workshop on Electronics for Particle Physics 2013, Perugia, Italy
- [6] *Xilinx*. Xilinx Website: <http://www.xilinx.com>

- [7] C.Solans et al., *Computing challenges in the certification of ATLAS Tile Calorimeter front-end electronics during maintenance periods*, 20th International Conference on Computing in High Energy and Nuclear Physics 2013, Amsterdam, Netherlands
- [8] E. Fullana et al., *Digital signal reconstruction in the ATLAS hadronic Tile Calorimeter*, 2006 IEEE Transactions on Nuclear Science 53 21392143