

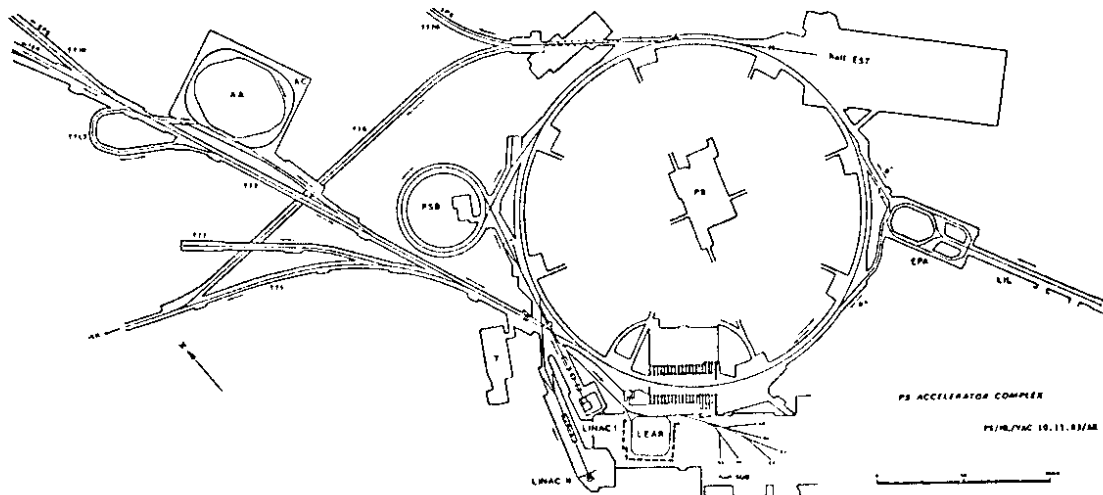

EUROPEAN ORGANIZATION FOR NUCLEAR RESEARCH

CERN/PS 84-1 (OP)

# STATISTICS OF PS OPERATION



# 1983

G. AZZONI AND K. PRIESTNALL

S T A T I S T I C S  
=====

O F P S O P E R A T I O N  
=====

1 9 8 3

Explanatory note

In order to clarify the figures quoted, it is necessary to give definitions of the headings for the various tables and to specify the time involved.

OVERALL PS SCHEDULED PERIOD is defined as the time which elapses between the end of one PS running period and the end of the next.

PS RUNNING PERIOD is defined as the time of continuous PS operation from the scheduled end of a PS start-up until the beginning of the next shut-down procedure and includes stops for breakdowns, etc.

HEP RUNNING PERIOD is a period of continuous PS operation for High Energy Physics. There are generally three such periods per PS running period, not necessarily of equal length and separated by a machine development period.

Changes since last year

- New table No. 21 : A VIEW OF PS PERFORMANCE FOR 1983
- New table No. 22 : LEAR STATISTICS
- New table No. 23 : ANNUAL STATISTICS FOR PS COMPLEX (Monthly)

# DEFINITIONS FOR A NORMAL RUNNING PERIOD

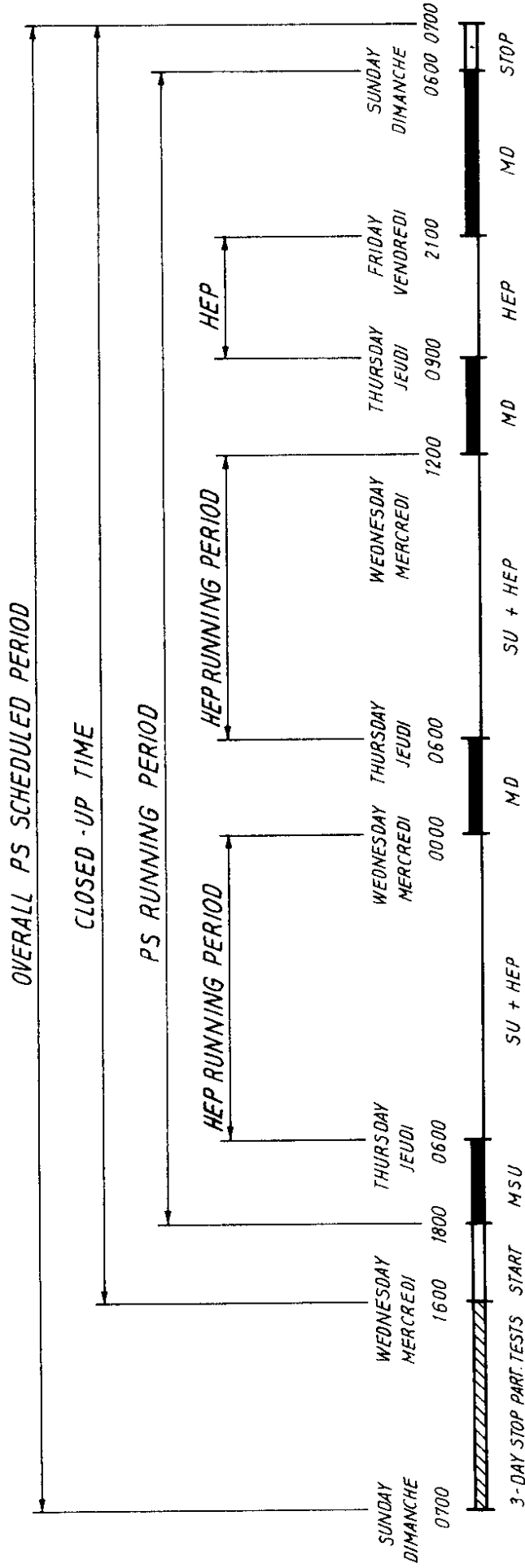

- MSU : Machine setting - up
- MD : PS and/or Booster Machine Development
- SU : Setting - up
- HEP : High Energy Physics (including ISR, SPS, AA and LEP)

• TABLE 1 : STATISTICS OF PS OPERATION

For each "overall PS scheduled period", the following statistics are given:

Clock time : total number of hours in the "overall PS scheduled period".

Closed-up time is the total of the following:

- HEP : time used for high energy physics
- MD : time used for machine development.
- MSU : time used for machine setting-up.
- Start/Stop : time allocated to starting up and stopping the PS.

Part. Tests (P.T.): time taken for magnet, Linac and PSB testing, prior to PS start-up.

Maintenance and Installation: self-explanatory.

Cooling-down and Miscellaneous: time allowed for PS cooling-down plus all the other time not included under the various headings of this chapter.

• TABLE 2 : DISTRIBUTION OF HEP TIME

Under this heading the time used for high energy physics is divided into four distinct categories (expressed as a percentage of total hours of HEP time), viz.:

ON TIME		<u>RUNNING %</u> : time during which the beam is actually used for high energy physics.
		<u>SETTING-UP %</u> : high energy operation setting-up time attributed to HEP
OFF TIME		<u>FAULTS %</u> : self-explanatory.
		<u>USER REQUEST %</u> : time during which PS is stopped at HEP users' request.

• TABLE 3 : HEP STATISTICS OF INTENSITY AND NUMBER OF PULSES

The total intensity, the total number of accelerated beam pulses and the average intensity are given. These are calculated for the entire HEP time in each "PS running period".

TABLE 4 : TOTAL DISTRIBUTION OF BEAM INTENSITY (HEP)

The distribution of the beam between the various targets and ejection systems is given for the HEP time of each "PS running period". Totals and percentages are quoted for the year 1983. (APST : Tests of AA injection and ejection at 3.5 GeV/c).

TABLE 5 : HEP STATISTICS

This gives the total number of hours of HEP time, the total number of accelerated beam pulses, the total intensity and the average intensity computed over the total time for the year 1983. The same figures are given for the period 1960-1982 inclusive and under "Grand Total" are given the overall totals and overall average for 1983 inclusive.

TABLE 6 : DISTRIBUTION OF MD TIME

Under this heading the time used for machine development is divided into two distinct categories, viz.:

ON TIME RUNNING % : self-explanatory.

OFF TIME FAULTS % : self-explanatory.

TABLE 7 : MD STATISTICS OF INTENSITY AND No. OF PULSES

The total intensity, the total number of accelerated beam pulses and the average intensity are given. These are calculated for the entire MD time in each "PS running period".

TABLE 8 : TOTAL DISTRIBUTION OF BEAM INTENSITY (MD)

The distribution of the beam between the various targets and ejection systems is given for the MD time of each "PS running period". Totals and percentages are quoted for the year 1983.

TABLE 9 : DISTRIBUTION OF MSU TIME

Under this heading the time used for machine setting-up is divided into two distinct categories, viz.:

ON TIME RUNNING % : self-explanatory.

OFF TIME FAULTS % : self-explanatory.

• TABLE 10 : MSU STATISTICS OF INTENSITY AND No. OF PULSES

The total intensity, the total number of accelerated beam pulses and the average intensity are given. These are calculated for the entire MSU time in each "PS running period".

• TABLE 11 : TOTAL DISTRIBUTION OF BEAM INTENSITY (MSU)

The distribution of the beam between the various targets and ejection systems is given for the MSU time of each "PS running period". Totals and percentages are quoted for the year 1983.

• TABLE 12 : PS STATISTICS

This gives the total number of hours of HEP + MD + MSU time, the total number of accelerated beam pulses, the total intensity and the average intensity computed over the total time for the year 1983. Under "Grand Total" are given the overall totals and overall average for 1960-1983 inclusive.

• TABLE 13 : FAULT DISTRIBUTION BY SYSTEM

This gives the breakdown time per "PS running period" according to the various PS systems\*. Totals and percentages for 1983 are given.

• TABLE 14 : VARIATION OF AVERAGE INTENSITY (HEP)

The evolution of average intensity during HEP time of each "PS running period" is plotted on a graph.

• TABLE 15 : PERCENTAGE OF FAULTS

This graph shows the percentage of faults per "PS running period".

• TABLE 16 : AVAILABILITY FOR THE SPS AND AA IN PERCENTAGE

This graph shows the availability for the SPS and AA in percentage. It is calculated for the HEP time of each "PS running period" according to the formulæ:

$$\text{and } \frac{\text{HEP time} - (\text{HEP faults} + \text{continuous transfer faults during HEP})}{\text{HEP time}} \quad \text{for the SPS}$$
$$\frac{\text{AA running-in time} - \text{total PS faults (as seen by AA)}}{\text{AA running-in time}} \quad \text{for AA}$$

\* See annex 1 for the meaning of each heading.

TABLE 17: FAULT DISTRIBUTION BY SYSTEM (No. of faults/total time)

This table gives the breakdown time for the year 1983, according to the various PS systems\*. The faults are further subdivided into particular time slices as follows:

0 to 10 minutes  
10 to 20 minutes  
20 min. to 1 hour  
1 to 3 hours  
3 to 6 hours  
more than 6 hours

TABLE 18: FAULT DISTRIBUTION BY SYSTEM FOR THE BOOSTER (No. of faults/total time)

This table gives the breakdown time for the Booster only, for the year 1983.

TABLE 19: STATISTIQUES AA (Y. Renaud)

Récapitulatif pour l'année 1983.

TABLE 20: 1983 PS SCHEDULE

TABLE 21: A VIEW OF PS PERFORMANCE FOR 1983

TABLE 22: STATISTIQUES LEAR - Mois de novembre et décembre 1983 (R. Ley)

TABLE 23: ANNUAL STATISTICS FOR PS COMPLEX (monthly)

Références

M. Bouthéon, OPERATION DU PS - EXPERIENCES DE PHYSIQUE, PS/OP/Notes 83-8, 83-14, 83-18, 83-21 et 84-2 ; MONTHLY MANAGEMENT REPORT-Technical parameters (décembre 1983)

Distribution (ouverte)

Liste PS/1 (Personnel Scientifique de la Division PS)

PS Co-ordinateur

L. Bernard  
F. Bonaudi  
G. Brianti  
H. Charmot  
M. Ciriani  
F. Coninckx  
C. Dutriat  
J. Guillet  
J.M. Hanon  
V. Hatton  
M. Höfert

M. Nielsen  
G. Plass  
G. Rau  
G. Rossat

A. Sullivan  
J.L. Vallet

\*See Annex 1 for the meaning of this heading.

TABLE 1

STATISTICS OF PS OPERATION

WEEK NO	CLOCK TIME (HOURS)	CLOSED - UP TIME												TOTAL SCHED (HOURS)	TOTAL WORKED (HOURS)	P T (HOURS)	MAINT. AND INSTAL. (HOURS)	COOLING DOWN AND MISCELLANEOUS (HOURS)
		HEP		MD		MSU		START/STOP (HOURS)										
		SCHEDULED (HOURS)	WORKED (HOURS)	SCHEDULED (HOURS)	WORKED (HOURS)	SCHEDULED (HOURS)	WORKED (HOURS)											
1-6	1056														240	816		
7-13	1176	920	920	78	78	20	20	20	20	27	27	1045	1045	34	24	24	73	
14-26	2184	2012	2012	21	21	26	26	26	26	3	3	2062	2062	34	24	24	64	
27	168															60	108	
28-34	1176	1008	1008	66	66	12	12	12	12	3	3	1089	1089	34	24	24	29	
35-40	1008	850	850	60	60	12	12	12	12	3	3	925	925	34	24	24	25	
41	168															60	108	
42-51	1680	1416	1403.30 <sup>1)</sup>	66	66	12	12	12	12	3	3	1497	1484.30 <sup>1)</sup>	34	24	24	125	
52	144																144	
TOTAL (HOURS)	8760	6206	6193.30	291	291	82	82	82	82	39	39	5618	5605.30	410	1056	1056	676	
PERCENT CLOCK TIME	100.0	70.8	70.7	3.3	3.3	0.9	0.9	0.9	0.9	0.5	0.5	75.5	75.4	4.7	12.1	12.1	7.7	
PERCENT CLOSED UP TIME	-	93.8	93.8	4.4	4.4	1.2	1.2	1.2	1.2	0.6	0.6	100.0	100.0	-	-	-	-	

1) Concerted work stoppage



**DISTRIBUTION OF HEP TIME IN HOURS (IN %)**

**TABLE 2**

WEEK N°	ON TIME		OFF TIME		TOTAL HOURS OF N.P. WORKED
	RUNNING	SETTING-UP	FAULTS	USER REQUEST	
1		<i>SCHEDULED</i>	<i>SHUT</i>	<i>DOWN</i>	
2		"	"	"	
3		"	"	"	
4		"	"	"	
5		"	"	"	
6		"	"	"	
7					
8					
9	8 32.55		74.04	13.01	920.00
10	(90.5)		(8.1)	(1.4)	
11					
12					
13					
14					
15					
16					
17					
18					
19	1 861.06		148.19	2.35	2 012.00
20	(92.5)		(7.4)	(0.1)	
21					
22					
23					
24					
25					
26					
27		<i>SCHEDULED</i>	<i>SHUT</i>	<i>DOWN</i>	
28					
29					
30	904.09		90.25	13.26	1 008.00
31	(89.7)		(9.0)	(1.3)	
32					
33					
34					
35					
36					
37	792.20		57.40		850.00
38	(93.2)		(6.8)		
39					
40					
41		<i>SCHEDULED</i>	<i>SHUT</i>	<i>DOWN</i>	
42					
43					
44					
45					
46	1 318.54		84.31	0.05	1 403.30
47	(94.0)		(6.0)	(-)	
48					
49					
50					
51					
52		<i>SCHEDULED</i>	<i>SHUT</i>	<i>DOWN</i>	
TOTAL %	92.2		7.3	0.5	100.0
TOTAL HOURS	5 709.24		454.59	29.07	6 193.30

# HEP STATISTICS OF INTENSITY AND N° OF PULSES

TABLE 3

WEEK N°	TOTAL INTENSITY [10 <sup>16</sup> pp <sup>+</sup> ]	AVERAGE INTENSITY [Tpp <sup>-1</sup> ]	NUMBER OF PULSES
1	<i>SCHEDULED</i>	<i>SHUT</i>	<i>DOWN</i>
2	"	"	"
3	"	"	"
4	"	"	"
5	"	"	"
6	"	"	"
7	1 583.3	8.17	1 938 926
8			
9			
10			
11			
12			
13			
14	3 058.5	10.34	2 958 485
15			
16			
17			
18			
19			
20			
21			
22			
23			
24			
25			
26			
27	<i>SCHEDULED</i>	<i>SHUT</i>	<i>DOWN</i>
28	1 170.6	7.02	1 666 853
29			
30			
31			
32			
33			
34			
35	1 032.3	7.23	1 428 463
36			
37			
38			
39			
40			
41	<i>SCHEDULED</i>	<i>SHUT</i>	<i>DOWN</i>
42	2 386.6	9.70	2 459 910
43			
44			
45			
46			
47			
48			
49			
50			
51			
52	<i>SCHEDULED</i>	<i>SHUT</i>	<i>DOWN</i>
<b>TOTAL</b>	<b>9 231.3</b>	<b>8.83</b>	<b>10 452 637</b>

1 Tpp<sup>-1</sup> = 10<sup>12</sup> pp<sup>-1</sup>

# TOTAL DISTRIBUTION OF BEAM INTENSITY (HEP)

ALL VALUES ARE IN 10<sup>16</sup> PROTONS

TABLE 4

WEEK No	DUMP TARGETS		CONTINUOUS TRANSFER	FAST EJECTIONS			SLOW EJECTION	TOTAL	
	APTST	93-97-D2		ISR + D2	16				62
					AA + D2	NEUTRINO			
7-13	2.7		59.0	31.8	222.2	1267.6	1583.3		
14-26	1.0		19.7	18.9	2721.2	296.5	3058.5		
28-34	0.4		577.9	17.3	550.6		1170.6		
35-40	1.0		779.8	6.1	210.6		1032.3		
42-51	1.3		1186.6	14.7	1167.5		2386.6		
TOTAL	6.4		2623.0	88.8	4872.1	1564.1	9231.3		
PERCENT	0.1		28.4	1.0	52.8	16.9	100.0		

# HEP STATISTICS

TABLE 5

YEAR	TOTAL HOURS WORKED	TOTAL NUMBER OF PULSES ACCELERATED	TOTAL NUMBER OF PROTONS [10 <sup>16</sup> ]	AVERAGE [T <sub>pp</sub> <sup>-1</sup> ]
TOTAL FOR 1983	<i>6 193.5</i>	<i>10 452 637</i>	<i>9 231.3</i>	<i>8.83</i>
TOTAL FOR 1960..1982	<i>112 868.3</i>	<i>162 765 530</i>	<i>52 038.3</i>	<i>3.20</i>
GRAND TOTAL [1960...1983]	<i>119 061. 8</i>	<i>173 218 167</i>	<i>61 269.6</i>	<i>3.54</i>

## DISTRIBUTION OF MD TIME IN HOURS (IN%)

TABLE 6

WEEK NO	ON TIME		OFF TIME		TOTAL HOURS OF MD WORKED
	RUNNING	SETTING-UP	FAULTS	USER REQUEST	
1		<i>SCHEDULED</i>	<i>SHUT</i>	<i>DOWN</i>	
2		"	"	"	
3		"	"	"	
4		"	"	"	
5		"	"	"	
6		"	"	"	
7					
8					
9	73.41		4.19		78.00
10	(94.5)		(5.5)		
11					
12					
13					
14					
15					
16					
17					
18					
19	21.00		-		21.00
20	(100.0)				
21					
22					
23					
24					
25					
26					
27		<i>SCHEDULED</i>	<i>SHUT</i>	<i>DOWN</i>	
28					
29					
30					
31	49.10		16.50		66.00
32	(74.5)		(25.5)		
33					
34					
35					
36					
37	54.58		5.02		60.00
38	(91.7)		(8.3)		
39					
40					
41		<i>SCHEDULED</i>	<i>SHUT</i>	<i>DOWN</i>	
42					
43					
44					
45	61.17		4.43		66.00
46	(92.9)		(7.1)		
47					
48					
49					
50					
51					
52		<i>SCHEDULED</i>	<i>SHUT</i>	<i>DOWN</i>	
TOTAL %	89.4		10.6		100.0
TOTAL HOURS	260.06		30.54		291.00

M D STATISTICS OF INTENSITY AND N° OF PULSES

TABLE 7

WEEK N°	TOTAL INTENSITY [10 <sup>16</sup> p <sup>+</sup> ]	AVERAGE INTENSITY [T <sub>pp</sub> <sup>-1</sup> ]	NUMBER OF PULSES
1	<i>SCHEDULED</i>	<i>SHUT</i>	<i>DOWN</i>
2	"	"	"
3	"	"	"
4	"	"	"
5	"	"	"
6	"	"	"
7	132.5	5.26	251 928
8			
9			
10			
11			
12			
13			
14	20.0	4.59	43 573
15			
16			
17			
18			
19			
20			
21			
22			
23			
24			
25			
26			
27	<i>SCHEDULED</i>	<i>SHUT</i>	<i>DOWN</i>
28	14.6	0.93	156 584
29			
30			
31			
32			
33			
34			
35	38.4	5.31	72 295
36			
37			
38			
39			
40			
41	<i>SCHEDULED</i>	<i>SHUT</i>	<i>DOWN</i>
42	215.1	8.18	263 012
43			
44			
45			
46			
47			
48			
49			
50			
51			
52	<i>SCHEDULED</i>	<i>SHUT</i>	<i>DOWN</i>
TOTAL	420.6	5.34	787 392

1 T<sub>pp</sub><sup>-1</sup> = 10<sup>12</sup> pp<sup>-1</sup>

# TOTAL DISTRIBUTION OF BEAM INTENSITY (M.D)

ALL VALUES ARE IN 10<sup>16</sup> PROTONS

TABLE 8

WEEK NO	APTST	DUMP TARGETS 93-97-D2	CONTINUOUS TRANSFER		FAST EJECTIONS				SLOW EJECTION	TOTAL
			SPS + D2		ISR + D2	16		NEUTRINO		
			SPS	D2		AA	D2			
7-13		122.5	0.6			9.4			62	132.5
14-26		2.5	4.0			13.5				20.0
28-34		11.6			1.7				1.3	14.6
35-40		19.9	18.5							38.4
42-51		188.3	21.6			5.2				215.1
TOTAL		344.8	44.7		1.7	28.1			1.3	420.6
PERCENT		82.0	10.6		0.4	6.7			0.3	100.0

**DISTRIBUTION OF MSU TIME IN HOURS (IN%)**

TABLE 9

WEEK NO	ON TIME		OFF TIME		TOTAL HOURS OF MSU WORKED
	RUNNING	SETTING-UP	FAULTS	USER REQUEST	
1		<i>SCHEDULED</i>	<i>SHUT</i>	<i>DOWN</i>	
2					
3					
4					
5					
6					
7					
8					
9	18.29		1.31		20.00
10					
11	(92.5)		(7.5)		
12					
13					
14					
15					
16					
17					
18					
19	21.13		4.47		26.00
20					
21	(81.5)		(18.5)		
22					
23					
24					
25					
26					
27		<i>SCHEDULED</i>	<i>SHUT</i>	<i>DOWN</i>	
28					
29					
30	12.00		-		12.00
31	(100.0)				
32					
33					
34					
35					
36					
37	6.09		5.51		12.00
38	(50.8)		(49.2)		
39					
40					
41		<i>SCHEDULED</i>	<i>SHUT</i>	<i>DOWN</i>	
42					
43					
44					
45					
46	11.06		0.54		12.00
47	(92.5)		(7.5)		
48					
49					
50					
51					
52		<i>SCHEDULED</i>	<i>SHUT</i>	<i>DOWN</i>	
TOTAL %	84.1		15.9		100.0
TOTAL HOURS	68.57		13.03		82.00



M S U STATISTICS OF INTENSITY AND N° OF PULSES

TABLE 10

WEEK N°	TOTAL INTENSITY [10 <sup>16</sup> p <sup>+</sup> ]	AVERAGE INTENSITY [I <sub>pp</sub> <sup>-1</sup> ]	NUMBER OF PULSES
1	SCHEDULED	SHUT	DOWN
2	"	"	"
3	"	"	"
4	"	"	"
5	"	"	"
6	"	"	"
7			
8			
9			
10	4.9	1.24	39 642
11			
12			
13			
14			
15			
16			
17			
18			
19			
20	14.8	2.79	53 122
21			
22			
23			
24			
25			
26			
27	SCHEDULED	SHUT	DOWN
28			
29			
30			
31	3.8	2.36	16 063
32			
33			
34			
35			
36			
37	6.1	3.09	19 740
38			
39			
40			
41	SCHEDULED	SHUT	DOWN
42			
43			
44			
45			
46	1.0	0.69	14 451
47			
48			
49			
50			
51			
52	SCHEDULED	SHUT	DOWN
TOTAL	30.6	2.14	143 018

1 I<sub>pp</sub><sup>-1</sup> = 10<sup>12</sup> pp<sup>-1</sup>

TOTAL DISTRIBUTION OF BEAM INTENSITY (M S U)

ALL VALUES ARE IN  $10^{16}$  PROTONS

TABLE 11

WEEK NO	DUMP TARGETS		CONTINUOUS TRANSFER		FAST EJECTIONS			SLOW EJECTION	TOTAL
	APTST	93-97-D2	SPS + D2		ISR + D2	16			
			AA	D2		NEUTRINO			
7-13		3.2					1.7		4.9
14-26	0.1	0.1	5.2			2.5	6.9		14.8
28-34	0.3		2.4					1.1	3.8
35-40			5.4					0.7	6.1
42-51			0.1		0.6			0.3	1.0
TOTAL	0.4	3.3	13.1		0.6	2.5	8.6	2.1	30.6
PERCENT	1.3	10.8	42.8		2.0	8.2	28.1	6.8	100.0

PS STATISTICS  
FOR HEP + MD + MSU

TABLE 12

YEAR	TOTAL HOURS WORKED	TOTAL NUMBER OF PULSES ACCELERATED	TOTAL NUMBER OF PROTONS [10 <sup>16</sup> ]	AVERAGE [T <sub>pp</sub> <sup>-1</sup> ]
TOTAL FOR 1983	6 566.5	11 383 047	9 682.5	8.51
TOTAL FOR 1960...1982	115 957.8	165 899 991	53 133.5	3.20
GRAND TOTAL [1960...1983]	122 524.3	177 283 038	62 816.0	3.54

TABLE 13

YEAR	1/1	14/2	4/3	4/7	11/7	29/8	10/10	17/10	26/12	TOTAL			
1983	13/2	3/3	3/7	10/7	28/8	9/10	16/10	25/12	31/12				
TIME WORKED HEP+MD+MSU (HOURS)	DOWN	1018	2059	DOWN	1086	922	DOWN	1481.30	DOWN	6566.30			
BREAK-DOWN TIME (HOURS)	SHUT	79.54	153.06	SHUT	107.15	68.33	SHUT	90.08	SHUT	498.56			
BREAK-DOWN TIME %	SCHEDULED	7.8	7.4	SCHEDULED	9.9	7.4	SCHEDULED	6.1	SCHEDULED	7.6			
FAULT DISTRIBUTION BY SYSTEM (HOURS)										PERCENTAGE			
										OF TOTAL TIME WORKED = 6566. <sup>h</sup> 30	OF TIME LOST = 498. <sup>h</sup> 56		
MACHINE	MAIN MAGNET & AUXIL.	4.43	1.03		3.59	5.03		7.43		22.31	0.34	4.5	
	MAIN GENERATOR	-	2.11		2.55	0.39		10.19		16.04	0.25	3.2	
	LINAC	5.28	7.47		7.45	7.50		14.54		43.44	0.67	8.8	
	BOOSTER	DOWN	6.17	57.14	DOWN	32.44	3.20	DOWN	16.15	DOWN	115.50	1.76	23.2
	INJECT.		3.12	15.10		5.41	0.43		13.48		38.34	0.59	7.7
	ACCEL.	SHUT	6.18	10.22	SHUT	5.54	2.24	SHUT	5.57	SHUT	30.55	0.47	6.2
	VACUUM		0.47	1.13		0.15	3.30		-		5.45	0.09	1.2
	EJECT. & TARGETS	SCHEDULED	2.22	7.02	SCHEDULED	0.03	0.27	SCHEDULED	-	SCHEDULED	9.54	0.15	2.0
	CONTROL		19.09	21.36		10.51	25.41		10.12		87.29	1.33	17.5
	BEAM TRANSPORT		26.55	5.11		9.53	-		2.56		44.55	0.68	9.0
	MISCELL.		4.40	1.54		-	1.03		8.04		15.41	0.24	3.1
EXTER. FAULTS		0.03	22.23		27.15	17.53		-		67.34	1.03	13.6	

TABLE 14

VARIATION OF AVERAGE INTENSITY  $[I_{pp}^{-1}]$   
 PER "HEP RUNNING PERIOD"  
 (PROGRAMMED INTENSITY)

1983

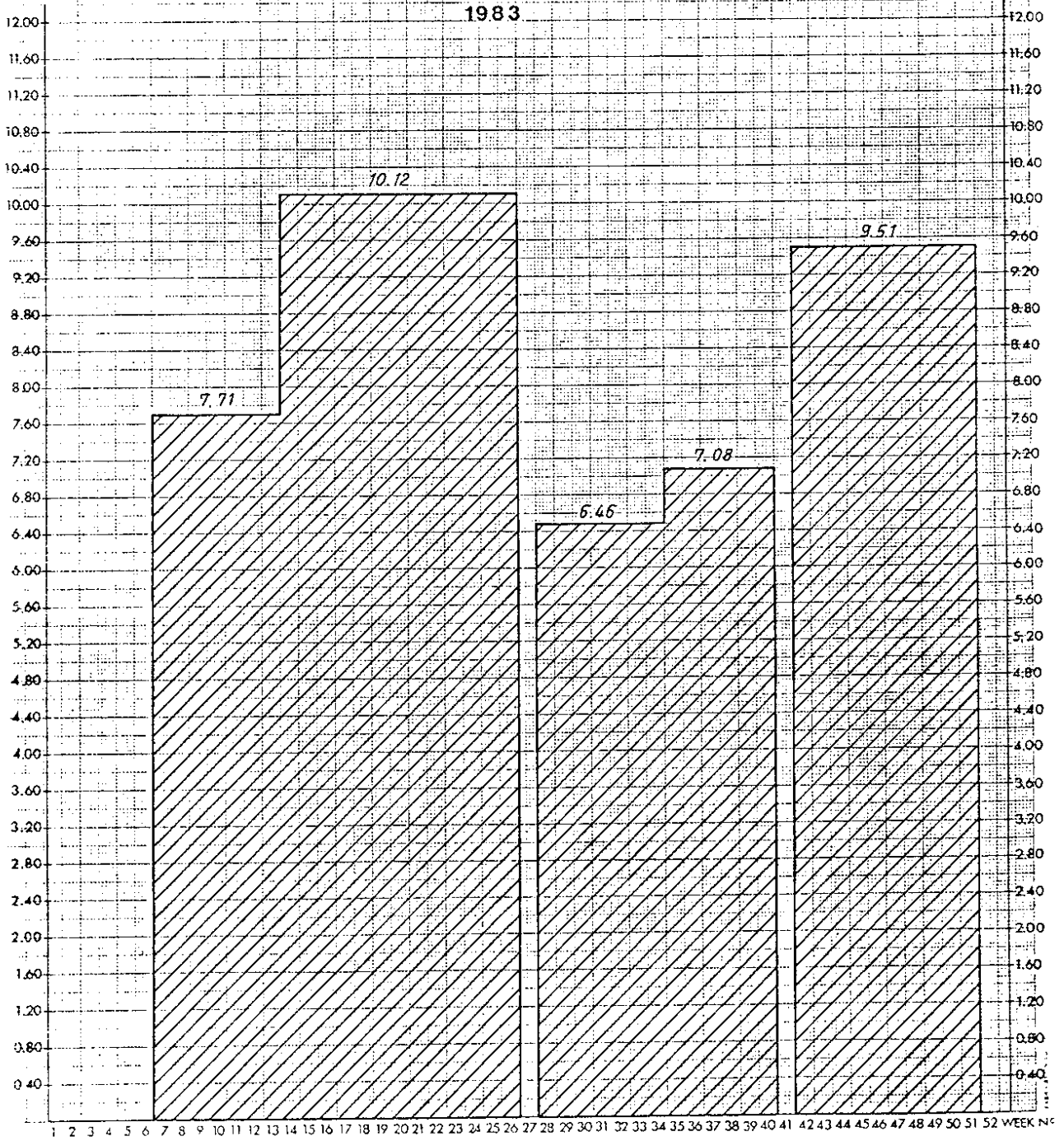



**AVAILABILITY FOR THE SPS AND AA IN PERCENTAGE  
PER "HEP RUNNING PERIOD"**

(AA)  
1983

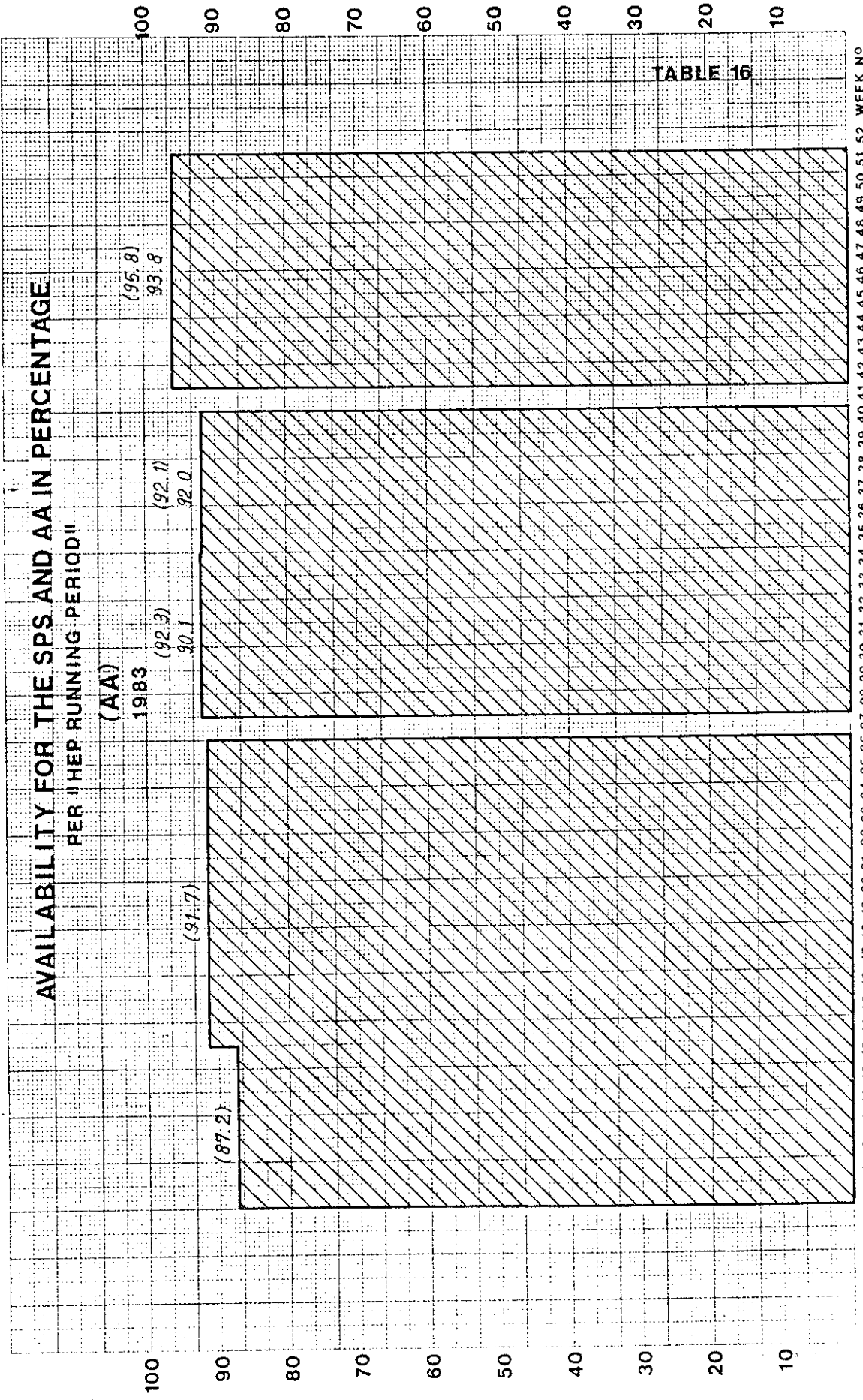

TABLE 16

1 2 3 4 5 6 7 8 9 10 11 12 13 14 15 16 17 18 19 20 21 22 23 24 25 26 27 28 29 30 31 32 33 34 35 36 37 38 39 40 41 42 43 44 45 46 47 48 49 50 51 52 WEEK NO

TABLE 17

## FAULT DISTRIBUTION BY SYSTEM (Number of faults/Total time)

YEAR	0'-10'	10'-20'	20'-1H	1H-3H	3H-6H	> 6H	TOTAL
1983	359/26. <sup>h</sup> 40	163/36. <sup>h</sup> 21	180/104. <sup>h</sup> 30	92/146. <sup>h</sup> 01	18/75. <sup>h</sup> 16	11/110. <sup>h</sup> 08	823/498. <sup>h</sup> 56
MAIN MAGNET & AUXILIARIES	43/2.33	10/2.10	13/7.08	2/4.02	2/6.38		70/22.31
MAIN GENERATOR	7/0.35	2/0.27	5/2.49	3/4.24		1/7.49	18/16.04
LINAC	69/5.18	23/4.51	22/14.20	8/12.38	2/6.37		124/43.44
BOOSTER	51/4.55	30/6.40	32/17.27	16/27.09	4/17.49	4/41.50	137/115.50
INJECTION	41/2.07	11/2.32	19/10.54	11/18.14	1/4.47		83/38.34
ACCELERAT.	20/1.38	25/5.46	14/8.53	11/14.38			70/30.55
VACUUM	1/0.08	4/0.53	1/0.47	2/3.57			8/5.45
EJECTION & TARGETS	24/1.30	11/2.15	5/3.24	2/2.45			42/9.54
CONTROL	91/7.01	40/9.14	52/27.53	23/34.49	2/8.32		208/87.29
BEAM TRANSPORT	7/0.35	3/0.43	10/5.46	8/14.00	3/14.08	1/9.43	32/44.55
MISCELL.	1/0.03	2/0.22	3/1.54	2/2.05	1/4.40	1/6.37	10/15.41
EXT. FAULTS	4/0.17	2/0.28	4/3.15	4/7.20	3/12.05	4/44.09	21/67.34
STOP ON REQUEST (Rx)							



TABLE 18

**FAULT DISTRIBUTION BY SYSTEM FOR THE BOOSTER (Number of faults/Total time)**

YEAR	0'-10'	10'-20'	20'-1H	1H-3H	3H-6H	> 6H	TOTAL
1983	51/4 <sup>h</sup> 55	30/6 <sup>h</sup> 40	32/17 <sup>h</sup> 27	16/27 <sup>h</sup> 09	4/17 <sup>h</sup> 49	4/41 <sup>h</sup> 50	137/115 <sup>h</sup> 50
AIMANT	7/0.39	5/1.09	2/0.59	7/13.32	2/10.14		23/26.33
ALIMENTAT.	37/3.49	21/4.39	24/13.43	5/6.39	2/7.35	1/8.38	90/45.03
KICKERS		1/0.11		1/1.48		1/10.05	3/12.04
ACCELERAT.			1/0.36			2/23.07	3/23.43
VACUUM							
CONTROL	5/0.17	1/0.10	2/0.56	3/5.10			11/6.33
MISCELL.	2/0.10	2/0.31	2/0.45				6/1.26
EXT.FAULTS			1/0.28				1/0.28

STATISTIQUES AA

Période : 1 9 8 3

I FONCTIONNEMENT AA

Heures prévues par schedule : 5091h

Heures effectivement réalisées : 5236h

ObservationsII PANNES PS

Total des pannes PS (vues par le AA) : 397h

Disponibilités du PS pour le AA : 92,3%

III PANNES AA

Total des pannes AA : 259h45

AA down time (sans perte de stack) : 5%

AA down time (avec " " " ) : 9,6%

Répartition des différentes pannes

AA inj. line : 68h46 Vacuum : 1h13

AA ej. line : 1h04 Comput controls : 13h58

AA ring el : 6h20 Timing : 13h28

Kickers : 25h37 Security : 1h30

Shutters : 9h36 Water : 33h37

RF : 12h00 Miscellaneous : 21h25

Stoc. cooling : 60h31

IV FONCTIONNEMENT EFFECTIF DU AA

a) Sans tenir compte des pertes de stack : 4976h soit 95%

b) En tenant compte des pertes de stack : 4733h soit 90,4%

V PRODUCTION D'ANTIPROTONS : 9816,4E<sup>9</sup> (en env. 2709h.)  
(env. 3,62 E<sup>9</sup>)VI PERTES DE STACK : 824,5 E<sup>9</sup>

représentant un temps d'accumulation de : 242h45



VII STACK MAXIMUM DURANT LA PERIODE : 2,83 x 10<sup>11</sup> le 17.11.1983



# 1983 ACCELERATOR SCHEDULE





MACHINE: PS

MD 

MD $\alpha$  

	JAN					FEB				MAR			
	1	2	3	4	5	6	7	8	9	10	11	12	13
MO	3	10	17	24	31	7	14	21	28	7	14	21	28
TU					1				1				<i>p-p</i>
WE									↓				<i>SPS</i>
TH						<i>ISR</i>			<i>AA SPS</i>				31
FR										<i>P1</i>			1
SA	<sup>1</sup>												
SU	<sup>2</sup>	9	16	23	30	6	13	20	27	6	13	20	27

	APR					MAY				JUN			
	14	15	16	17	18	19	20	21	22	23	24	25	26
MO	4	11	18	25	2	9	16	23	30	6	13	20	27
TU									31				
WE									1				
TH													30
FR						<i>P2</i>							
SA				30									
SU	10	17	24	1	8	15	22	29	5	12	19	26	3

	JUL					AUG				SEP			
	27	28	29	30	31	32	33	34	35	36	37	38	39
MO	4	11	18	25	1	8	15		29	5	12	19	26
TU													
WE									31				
TH							<i>α α</i>		1				30
FR					<i>P3</i>					<i>P4</i>			1
SA													
SU	10	17	24	31	7	14	21	28	4	11	18	25	2

← AA STOP →



	OCT					NOV				DEC			
	40	41	42	43	44	45	46	47	48	49	50	51	52
MO	3	10	17	24	31	7	14	21	28	5	12	19	26
TU					1							<i>p-p</i>	
WE									30			<i>SPS</i>	
TH													
FR			<i>P5</i>										
SA													31
SU	9	16	23	30	6	13	20	27	4	11	18	25	

TABLE 21

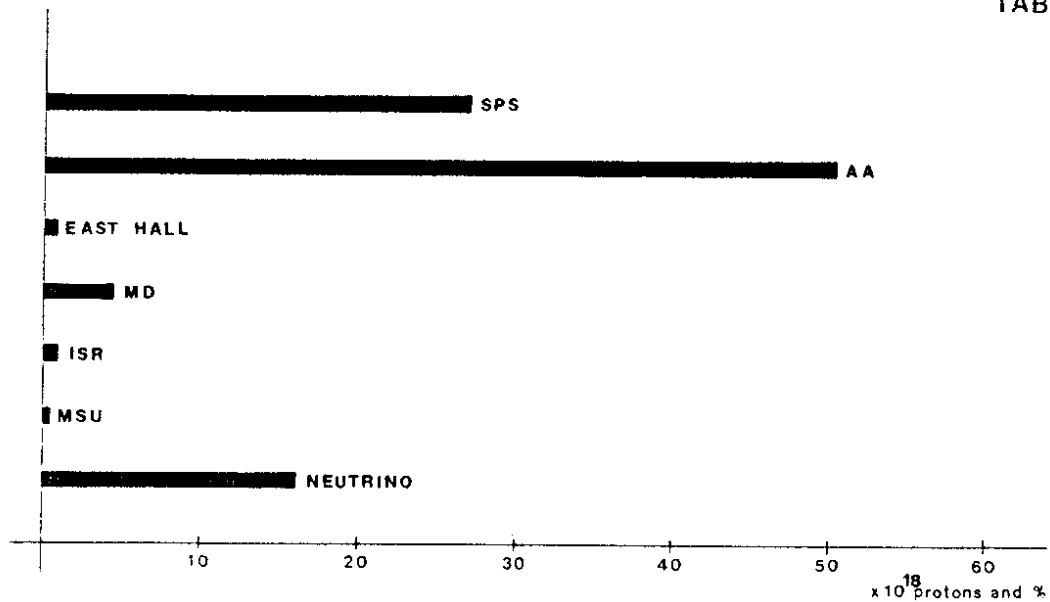

Fig.1 GENERAL DISTRIBUTION OF p ACCELERATED BY THE PS IN 1983

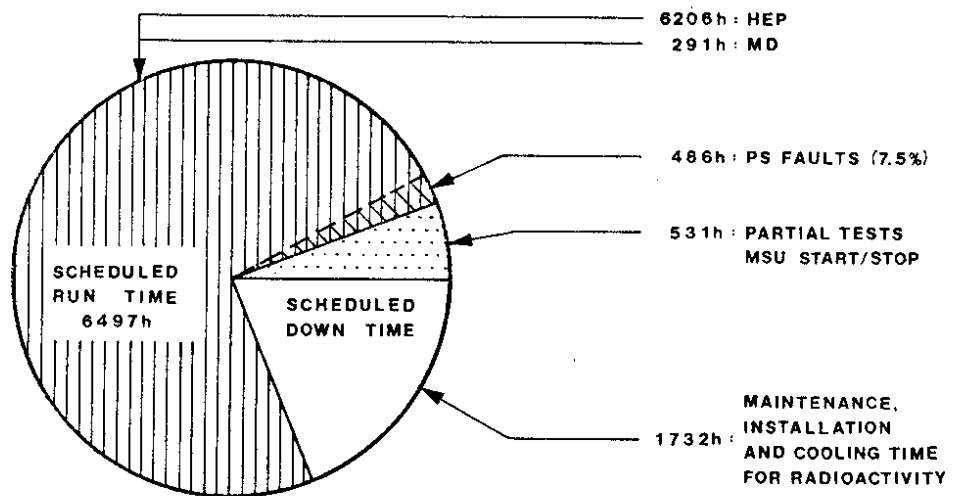

Fig.2 DIVISION OF PS CAKE FOR 1983

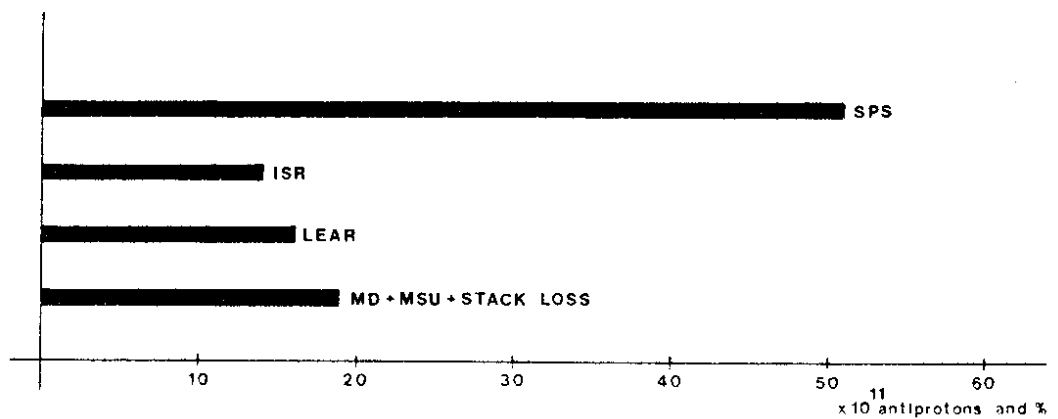

Fig.3 GENERAL DISTRIBUTION OF p̄ BY AA IN 1983

STATISTIQUE LEAR POUR NOVEMBRE 1983

		p	$\bar{p}$
MD +	Jours prévus <sup>*)</sup>	13,5	
	Jours réalisés	13	
P H Y S I Q U E	Jours prévus <sup>**)</sup>		9
	Jours réalisés		9
	total impulsions <sup>***)</sup>		84
	Impulsions réalisées		72
	Impulsions perdues		12

STATISTIQUE LEAR POUR DECEMBRE 1983

		p	$\bar{p}$
MD +	Jours prévus	2 <sup>*)</sup>	2 <sup>**)</sup>
	Jours réalisés	2	2
P H Y S I Q U E	Jours prévus		15 <sup>**)</sup>
	Jours réalisés		13
	total impulsions		149 <sup>***)</sup>
	Impulsions réalisées		135
	Impulsions perdues		14

<sup>\*)</sup> 24 h/24 h

<sup>\*\*)</sup> 12 h/24 h

<sup>\*\*\*)</sup> Spill de 1 heure

R. Ley

TECHNICAL PARAMETERS

ACCELERATORS	JANUARY	FEBRUARY	MARCH	APRIL	MAY	JUNE	JULY	AUGUST	SEPTEMBER	OCTOBER	NOVEMBER	DECEMBER	TOTAL
SC													
Hours scheduled for physics	372	616	664	280	656	612	288		S	608	672	448	5216
Hours given to physics	358	606	664	154	605	573	276		H	80	643	428	4387
Hours given/hours scheduled	96.2%	98.4%	100%	53.6%	92.2%	93.6%	95.8%		U	13%	97.5%	95.5%	84.1%
Hours scheduled for MD+Setting-up	28	16	18	16	52	8	8		T	48	8	20	222
Hours given to machine development	25	10	9	28	50	38	6		D	48	16	17	247
Total hours scheduled	400	632	682	296	708	620	296		O	656	680	468	5438
Total hours realised	383	616	673	182	655	611	282		W	128	659	445	4634
PS									N				
Hours scheduled for physics		208	708	574	688	720	430			400	654	528	6206
Hours given to physics		197	645	523	646	667	396		684	366	612	502.3)	5738
Hours given/hours scheduled		94%	91.1%	91.1%	93.9%	92.6%	92.1%		632	91.5%	93.6%	95.1%	92.4%
Hours scheduled for MD+Setting-up		88	36	15	14	-	66		92%	45	66	1	412
Hours given to machine development		83	36	13	11	-	66		36	40	61	1	368
Total hours scheduled		296	744	589	702	720	495		31	445	720	529	6618
Total hours realised		280	681	536	657	667	461		663	406	673	503	6106
- LINAC 2													
Hours scheduled		296	744	589	702	720	496		720	445	720	529	6618
Hours realised		296	740	585.5	700	717	496		712	438	714	515.3)	6564
Hours realised/hours scheduled		100%	99.5%	99.4%	99.7%	99.6%	100%		99%	98.4%	99.2%	97.5%	99.2%
- PSB													
Hours scheduled		296	744	589	702	720	496		720	445	720	529	6618
Hours realised		294	738	567	679	708	480		708	435	708	514.3)	6472
Hours realised/hours scheduled		99%	99%	96%	97%	98.3%	96.8%		98.3%	97.8%	98.3%	97.3%	97.8%
- AA													
Hours scheduled		651	651	565	702	720	416		390	350	720	528	5236
Hours realised		583	583	542	686	614	350		383	316	607	446.3)	4719
Hours realised/hours scheduled		90%	90%	96%	97.7%	85%	84%		98.2%	90%	84.3%	84.5%	90%
- LINAC 1													
Hours scheduled													
Hours realised													
Hours realised/hours scheduled													
LEAR													
Hours scheduled for physics (p̄)													
Number of spills given to physics <sup>2</sup>													
Number of spills lost													
Efficiency													
Hours scheduled for MD+Setting-up (p̄p̄)													
Hours given													

1) Included p̄ stack losses  
 2) 1 h. p̄ spill time  
 3) Included concerted work stoppage

FAULT DISTRIBUTION BY SYSTEM

1. Main magnet and auxiliaries

Here are gathered all the faults of the PS magnets (PR.BHZ), the cooling system, the PFWs (PP.W), the "high energy" quadrupoles (PR.Q ), the sextupoles (PR.X ), the Tekelecs type power supplies (PP.T ), the power supplies for type "D" (PP.D ), the power supplies for type "M" (PP.M ), the equipment for "B" and "BO.1" train generation (PX.TB ), the shims, the octupoles (PR.O ) and the dipoles (PR.D).

2. Main generator

All the faults concerning the main magnet power supply are classed in this section.

3. Linacs I and II

All the Linac faults (including controls) for the old (Linac I) and the new (Linac II) are found here, except for vacuum faults (see the vacuum diagram annexed).

4. Booster

All the Booster faults (vacuum, RF, controls, etc.) are classed here, beginning from I-VS2 (BI.VVS10) up to T-VS5 (BTP.VVS20) for the vacuum; the ejection line to the PS up to T-Q05 (BTP.QN010) inclusive (transfer line) for the magnet units; the transfer line up to and including TIS (PI.SMH42) for the magnet power supplies and for demineralized water supply.

5. Injection

This section comprises all the faults related to 50 MeV and 800 MeV injection, viz.:

Inflector 26 (PI.SMH26), injection quadrupoles (PI.QNO), BLW (PI.DHZ), vertical dipoles (PI.DVT), KM28 (PI.KFA28), BD44 (PTE.DVT10), kicker 22 (PI.KSW22) and 30 (PI.KSW30), skewed quadrupoles (PI.QSK ), injection sextupoles (PI.XNO et SK), the Booster injection line to the PS (transfer line), i.e. the magnet after T-Q05 (BTP.QN010), ((T-Q06 .....10, BTP.QN020 ...60), T-DH03 ...5 (BTP.DHZ20 ...40), T-DV05 ...9 (BTP.DVT10 ...50), BLM (PR.MBL ), T-TRI (PI.TFA), T-TR2 (BTP.TRA , Sem Grids (PR.MSG), TV30-34-46 (PR.MTV30-34-46), TU2...5 (BTP.UES00...30), TIK (PI.KFA45), TIS (PI.SMH42), SB40...44 (PI.BSM40...44)), beam dumper (PR.STP ), and the new equipment: the fast kicker (PI.KFA28), horizontal dipoles (PTE.DHZ10), Sem Grid 26 (PI.MSGH26L, MSGH26P, MSGV26L), TV 26 (PR.MTV26).

## 6. Acceleration

All the faults related to the radio-frequency (beam control, cavities, etc.) which can be defined as active equipment are found here; plus all the faults concerning what can be called the passive part, I measuring system (PR.TRA72), the ACEM detectors (PR.MBL ), the pick-up stations (PR.U). (See annex 2 for passive part).

## 7. Vacuum

All faults related to the PS, Linac I, Linac II, FA58, ligne FT16 and LEAR are found here, according to their position in the layout (see vacuum diagrams annexed).

## 8. Ejection - targets

Here are classed all the faults concerning the FAK (PR.KFA), fast bumpers (PE.BFA), the septa (PR.SMH), the internal targets (PR.TP, PR.TM), the dump targets (PR.TD), the ejected beam servo system, the minitoposcopes (PR.MTO), the "Cerenkovs", the TV's (PR.MTV), the septa and external targets lighting equipment, the measuring transformer for extracted beam, the SEC's and the BLM's (PR.MBL ).

## 9. Control

All the faults of the various parts of the centralised PS computer system are found here, plus the security ((beam stoppers (BI.STP.BRI. STP-BTP.STP), fire detection equipment, barriers, etc.)), the timing (pulse distribution to linac, MCR, CB, etc.).

Note: 1) The faults due to security are put here.

2) As indicated in 3. and 4., the controls faults are included for the Linacs and the Booster as in the past.

## 10. Miscellaneous

All the faults found here will be dealt with in detail in Annex 3.

## 11. Beam transport

All the faults related to the separators, the magnets, the quadrupoles and their cooling system, the vacuum ejected beams, the septa (ex. MNP 35/1-2) and the hydrogen targets are to be found in this section; plus the ATP1, ATP2, FTD, TT2 and FA58 lines.

## 12. External faults

All the faults which are not attributed to an element found in or around the PS, i.e. thunderstorms, mains failures, stops due to SB causes (water supply, water pump below door 4, ventilation, etc.) are classed here. (Details in Annex 4).



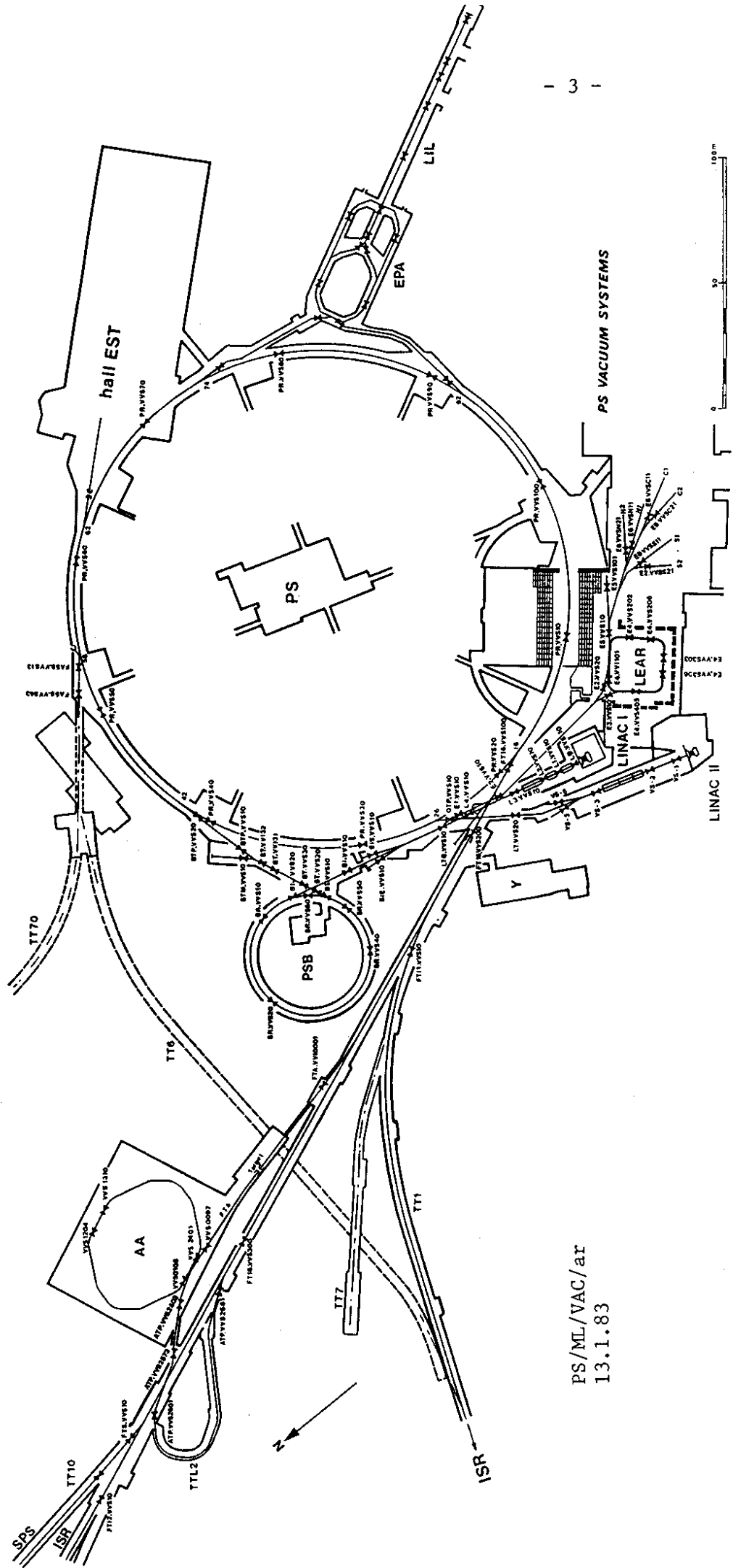

PS/ML/VAC/ar  
13.1.83

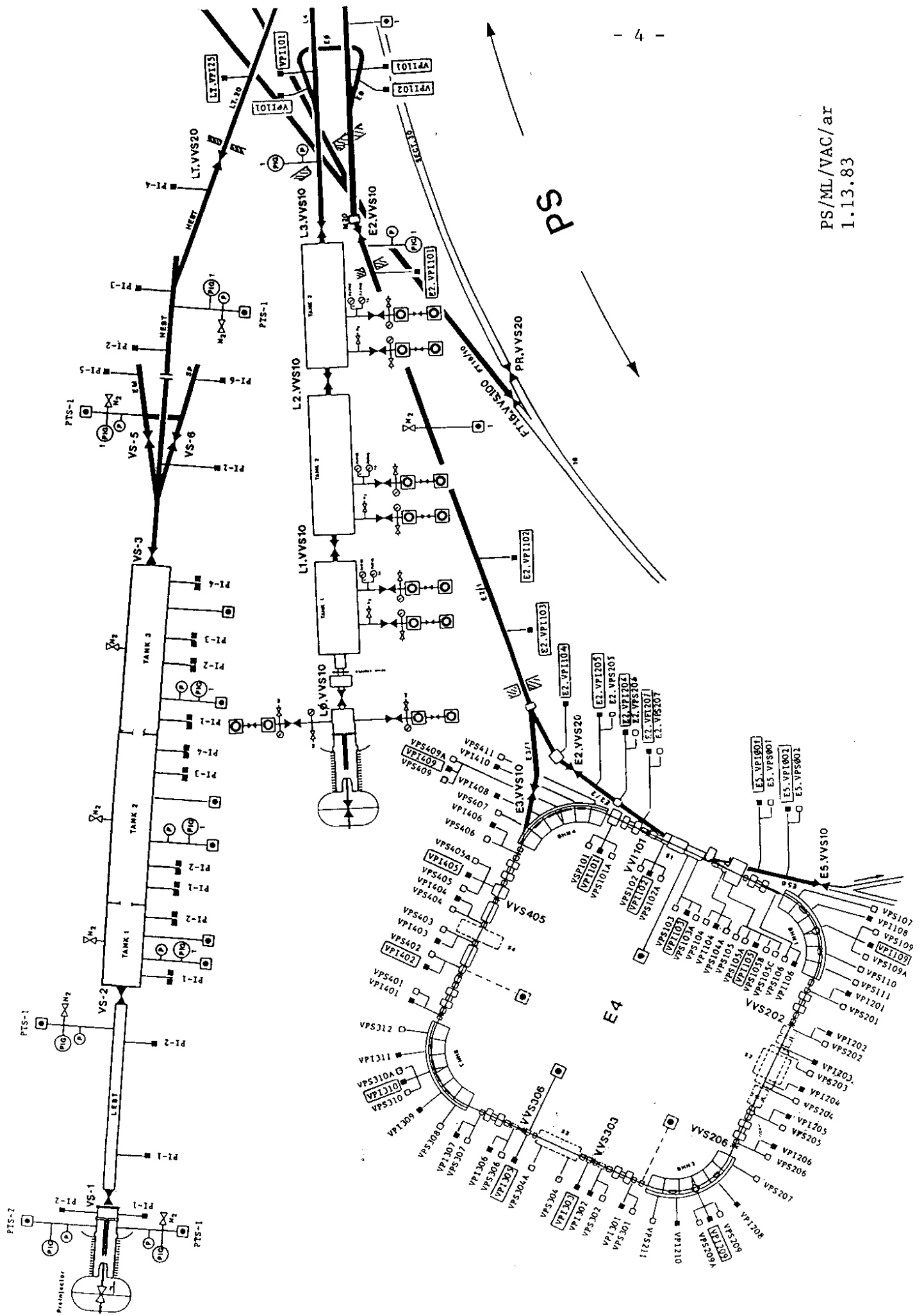

PS/ML/VAC/ar  
1.13.83



# LINAC 1

PS/ML/VAC/ar  
13.1.83

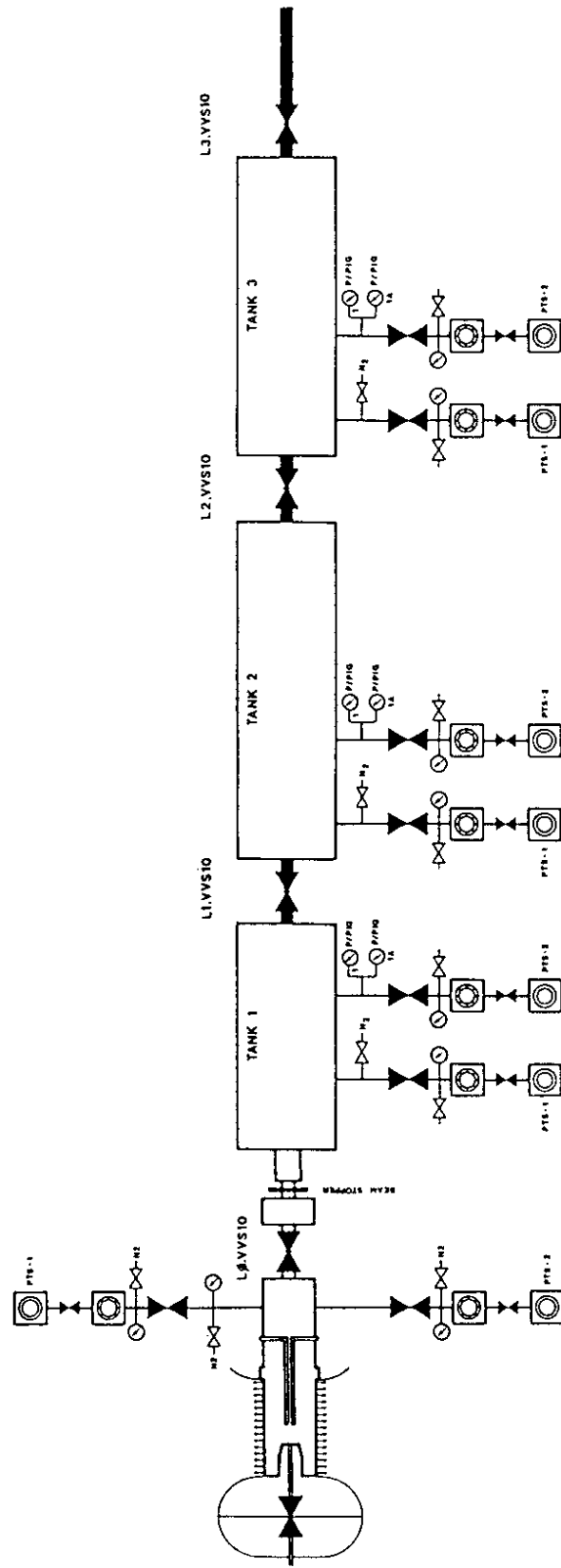

# LINAC II

PS/ML/VAC/ar  
13.1.83

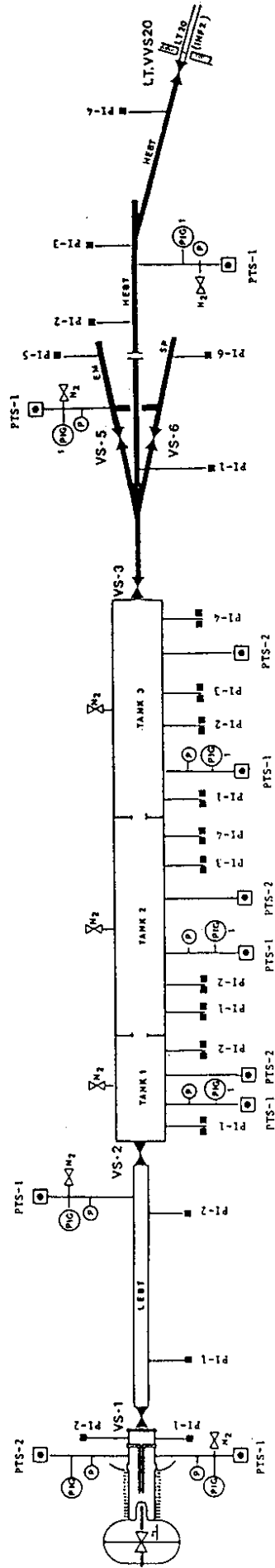

PS/ML/VAC/ar  
13.1.83

# LIGNE FT16

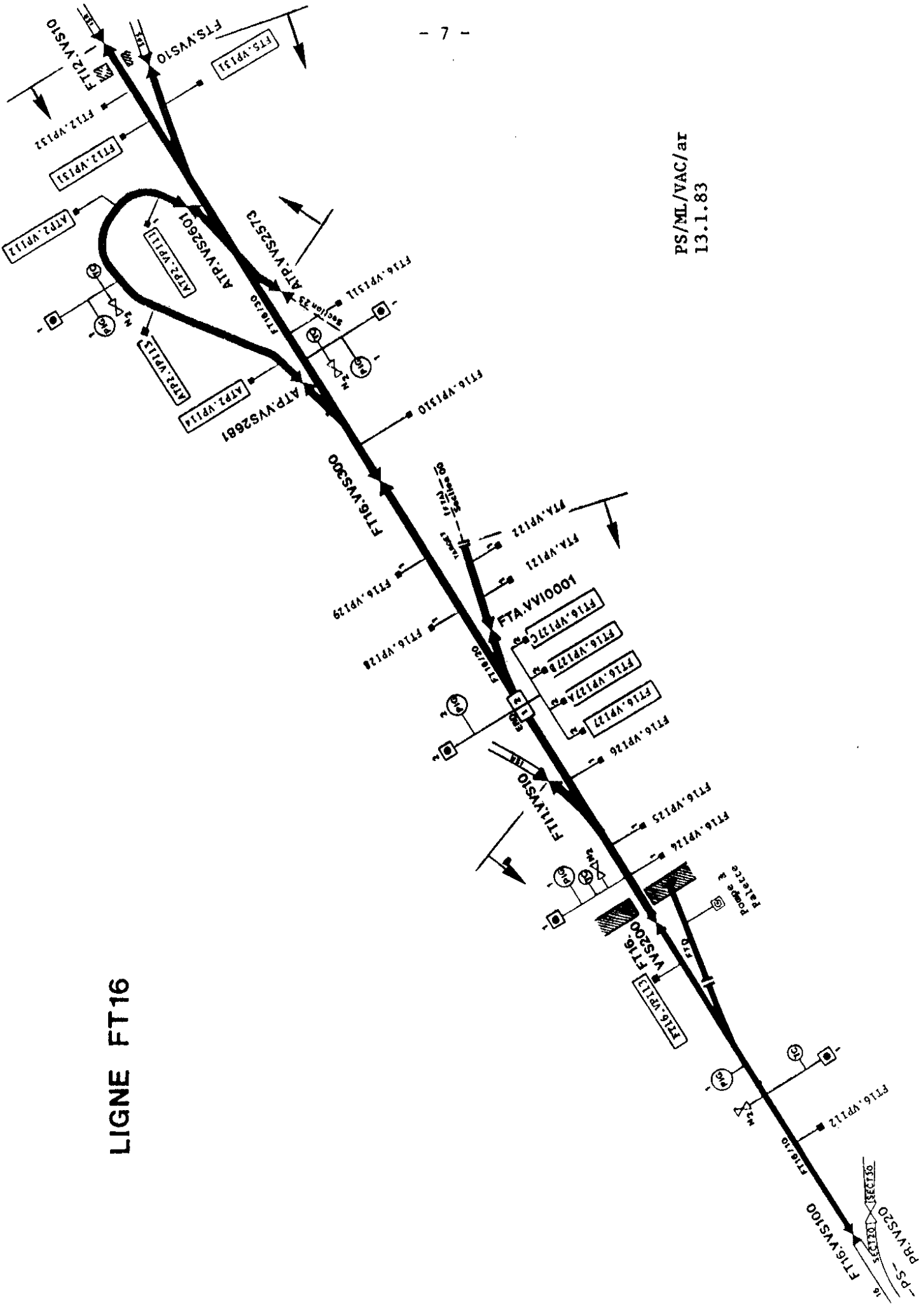

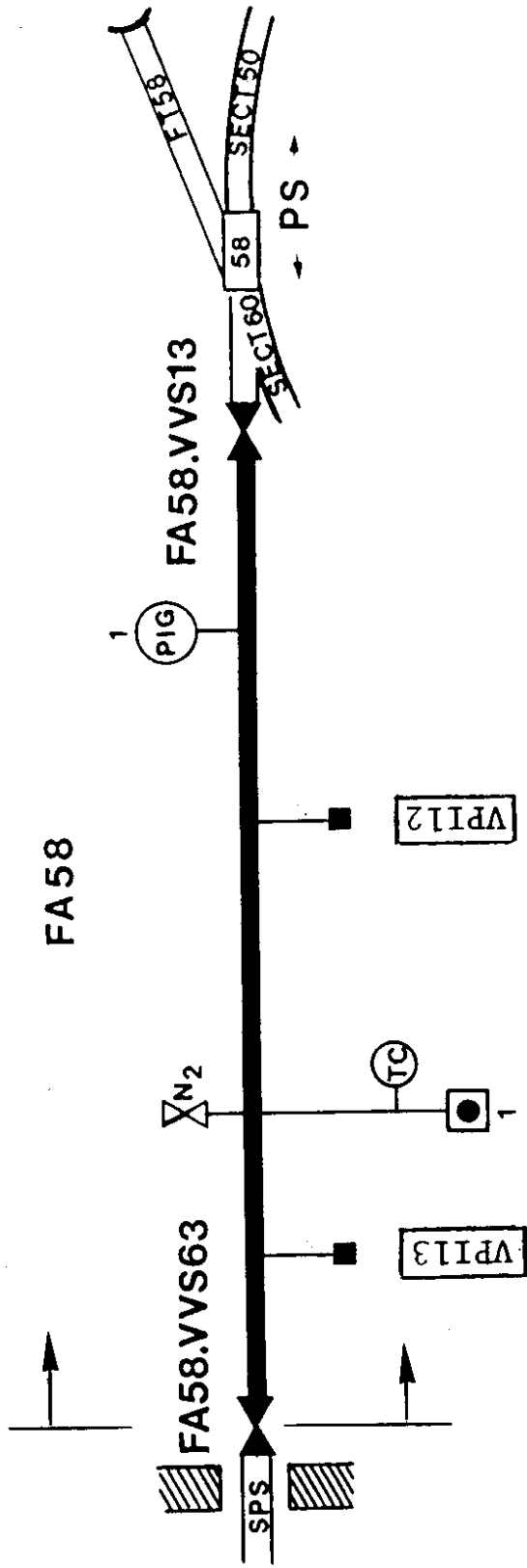

PS/ML/VAC/ar  
13.1.83

PASSIVE PART ACCELERATION FAULTS (No. of hours) 1983

	0h30	Transversal feedback (Period 1)
	<u>0h14</u>	Transversal feedback (Period 3)
TOTAL	0h44	



MISCELLANEOUS FAULTS (No. of hours) 1983

4h40	Operating fault	(Period 1)
0h40	Low energy racks switched off by PS Staff	(Period 2)
0h20	LEAR - VACUUM	" "
0h54	" "	" "
0h03	Ejection 16 Security (AA fault)	(Period 4)
1h00	No reason found	" "
0h11	LEAR (adj.)	(Period 5)
1h05	Operating fault	" "
0h11	LEAR (adj.)	" "
<u>6h37</u>	CCR modification (resulting in a short circuit)	" "
TOTAL	15h41	

EXTERNAL FAULTS (No. of hours) 1983

0h03	Ejection 16 Security (SPS fault)	(Period 1)
0h17	Mains failure	(Period 2)
0h11	" "	" "
1h23	" "	" "
0h02	" "	" "
0h05	" "	" "
2h45	" "	" "
17h40	" "	" "
2h06	Mains failure	(Period 3)
0h07	" "	" "
3h17	SIG - OPERATING FAULT	" "
11h29	Mains failure	" "
0h50	" "	" "
0h50	" "	" "
1h06	" "	" "
7h30	" "	" "
3h55	Mains failure	(Period 4)
4h53	" "	" "
0h46	" "	" "
0h49	" "	" "
7h30	" "	" "
<u>TOTAL</u>	67h34	

FAULTS EXCEEDING 6 HOURS (No. of hours) 1983

9h43	TT7 SAFE - QF 229 (over temp. protection fault)	(Period 1)
17h40	Mains failure	(Period 2)
8h38	PSB - PI.SMH42	" "
15h59	PSB RF Cavity	(Period 3)
10h05	PSB - BI.KSW	" "
11h29	Mains failure	" "
7h30	" "	" "
7h30	" "	(Period 4)
7h08	PSB RF Cavity	(Period 5)
6h37	CCR modification (resulting in a short circuit)	" "
7h49	Main Generator (speed sensor)	" "
<u>TOTAL</u> 110h08		