



CLIC – Note – 936

COMPARATIVE STUDY OF EXPERIMENTAL SIGNALS FOR MULTIPACTOR AND BREAKDOWN

M. Dehler^(1,2), S. Verdú-Andrés^(3,4), W. Wuensch⁽²⁾, A. Faus-Golfe⁽⁴⁾, B. Gimeno Martinez⁽⁵⁾,
J. Kovermann⁽²⁾, V. Boria⁽⁶⁾, D. Raboso⁽⁷⁾

⁽¹⁾European Organization for Nuclear Research CERN, Switzerland

⁽²⁾Paul Scherrer Institut PSI, Switzerland

⁽³⁾TERA Foundation, Italy

⁽⁴⁾Instituto de Física Corpuscular, IFIC (CSIC-UV), Spain

⁽⁵⁾Universidad de Valencia, Spain

⁽⁶⁾Universidad Politécnica de Valencia, UPV, Spain

⁽⁷⁾High Power RF laboratory of European Space Agency, Spain

Abstract

Performance limiting high-power rf phenomenon occur in both transmitter systems in satellites and high-gradient accelerating structures in particle accelerators. In satellites the predominant effect is multipactor while in accelerators it is breakdown. Both communities have studied their respective phenomena extensively and developed particular simulation tools and experimental techniques. A series of experiments to directly compare measurements made under multipactor and breakdown conditions has been initiated with the objective to crosscheck and compare the physics, simulation tools and measurement techniques.

Presented at: MULCOPIM, Valencia, September 21-23, 2011

Geneva, Switzerland
May 2012



Comparative study of experimental signals from multipactor and breakdown

M. Dehler^(1,2), S. Verdú-Andrés^(3,4), W. Wuensch⁽⁵⁾, A. Faus-Golfe⁽⁶⁾, B. Gimeno Martinez⁽⁷⁾, J. Kovermann⁽⁸⁾,
V. Boria⁽⁹⁾, D. Raboso⁽¹⁰⁾

⁽¹⁾*European Organization for Nuclear Research CERN
CH-1211 Geneva 23, Switzerland
Micha.Dehler@psi.ch*

⁽²⁾*Paul Scherrer Institut
CH-5232 Villigen PSI, Switzerland*

⁽³⁾*TERA Foundation
Via G. Puccini, 11
I-28100 Novara, Italy
Silvia.Verdu.Andres@cern.ch*

⁽⁴⁾*Instituto de Física Corpuscular, IFIC (CSIC-UV)
Edificio Institutos de Investigación
E-46100 Paterna (Valencia), Spain*

⁽⁵⁾*European Organization for Nuclear Research CERN
CH-1211 Geneva 23, Switzerland
Walter.Wuensch@cern.ch*

⁽⁶⁾*Instituto de Física Corpuscular, IFIC (CSIC-UV)
Edificio Institutos de Investigación
E-46100 Paterna (Valencia), Spain
Angeles.Faus-Golfe@uv.es*

⁽⁷⁾*Universidad de Valencia
E-46100 Burjasot (Valencia), Spain
Benito.Gimeno@uv.es*

⁽⁸⁾*European Organization for Nuclear Research CERN
CH-1211 Geneva 23, Switzerland
Jan.Kovermann@cern.ch*

⁽⁹⁾*Universidad Politécnica de Valencia, UPV
Camino de Vera s/n
E-46022 Valencia, Spain
vboria@dcom.upv.es*

⁽¹⁰⁾*High Power RF laboratory of European Space Agency
Universidad Politécnica de Valencia
Camino de Vera s/n, CPI (Edificio 8G - Acceso B - Planta B),
E- 46022 Valencia, Spain
David.Raboso@esa.int*

ABSTRACT

Performance limiting high-power rf phenomenon occur in both transmitter systems in satellites and high-gradient accelerating structures in particle accelerators. In satellites the predominant effect is multipactor while in accelerators it is breakdown. Both communities have studied their respective phenomena extensively and developed particular simulation tools and experimental techniques. A series of experiments to directly compare measurements made under multipactor and breakdown conditions has been initiated with the objective to crosscheck and compare the physics, simulation tools and measurement techniques.

INTRODUCTION

An important part of particle accelerators are RF accelerating structures, microwave resonators driven by high power transmitter tubes as klystrons used to accelerate the particle beam.

Compact normal conducting high-gradient linacs, those with accelerating gradients in the range of 50 -100 MV/m are being considered in a number of applications including free electron lasers, Compton scattering sources and linear colliders. Additionally, carbon ion cancer therapy linacs are being proposed with surface gradients as high as for the aforementioned machines. The application with the highest gradient requirement is the CLIC study planned to be a 3.0 TeV electron positron collider with an overall footprint of 48 kilometers size. Important elements of this are RF accelerating structures operating at elevated accelerating gradients (leading in the case of CLIC to surface gradients of 200-300 MV/m). A large number of these are needed (~100'000) and breakdown in one single structure already leads to a loss of beam for the whole pulse, so the probability of a break down needs to be extremely low ($3 \cdot 10^{-7}$ per pulse per meter for an RF pulse length of 240 ns) in comparison with the standard accelerator applications. The common feature among all of the applications is that RF breakdown thresholds give one of the main performance limitations.

In that context, CERN, within a worldwide collaboration with KEK (Japan) and SLAC (USA), conducts an experimental program to manufacture and test accelerator structures. The current progress is such, that a base line production process has been established yielding the specified performance, but research focused onto simplified, mass production techniques while retaining reproducible high performance results will be an important goal in the future. Better understanding the critical parameters of the underlying physical processes should be extremely useful in that respect.

Lots of the physics relevant in describing RF breakdowns is also relevant in the study of multipactor and intermodulation effects in waveguides and microwave filters. So this proposal seeks to identify synergies and possibly define first evaluative experiments, which we can be carried out at the facilities of VALSPACE, a consortium formed by the Generalitat Valenciana, the city hall of Valencia, Universidad Politécnic de Valencia and Universidad de Valencia Estudi General to conduct scientific research and technological development in the space sector. The proposal centers on developing practical methods to characterize the free charge distribution in the pre breakdown (field emission) and breakdown (plasma) phase using different methods like probe signals or intermodulation. The continuous and predictable nature of multipactor makes it the logical place to start the development.

Instead of a fully featured RF structure, we plan to use a relatively basic RF resonator running at modest power levels, which allows a relatively wide spectrum of measurements. The main objective is to develop passive and active means of probing free electrons which are produced in high power phenomenon like multipactor and breakdown. The continuous and predictable nature of multipactor makes it the logical place to start the development.

The hardware system needed to make such measurements is described here. If the efforts are successful, they should be useful in providing basic data for benchmarking multipactor simulations. The techniques will also then be applied to rf breakdown in high gradient structures. A second objective here is to provide basic data for benchmarking the ongoing breakdown simulations.

BACKGROUND TO HIGH POWER PHENOMENA

Nonlinear electromagnetic effects affect the operation of RF cavities in various ways. Resonant multipactor often happen in coaxial type couplers of lower frequency standing wave cavities up to 1.5 GHz and can create regions of operation, where the available drive power dominantly flows into the multipacting process instead of feeding the resonance.

Where the critical parameters describing multipacting are the second secondary electron yield of the materials used and a resonance condition given by the local geometry of the resonator in combination with the field gradient, a second class of phenomena is caused by field emission.

High electric gradients on metallic surfaces lead to the field emission of electrons. They are able to tunnel from the conduction band into free space, an effect described by the Fowler Nordheim equation [1]. The critical parameters are the local field gradient, possibly enhanced by surface roughness and material impurities as oxide layers, and the work function of the bulk material, which may be affected by material impurities and defects in the crystal structure. The emitted electrons get accelerated by the rf fields, before (typically) hitting other surfaces and being absorbed. The current is not directly visible from the outside, so it is labeled as dark current. In practice, it becomes visible in the field energy absorbed by the emitted and accelerated electrons. If we raise the field amplitude in the structure, the internal quality factor of the structure goes down, as the power absorbed by the dark current starts to dominate over conduction losses in the resonator wall. In addition the distribution of the heat load on the cavity walls will change, from locations with high current density to those getting hit by field emitted electrons.

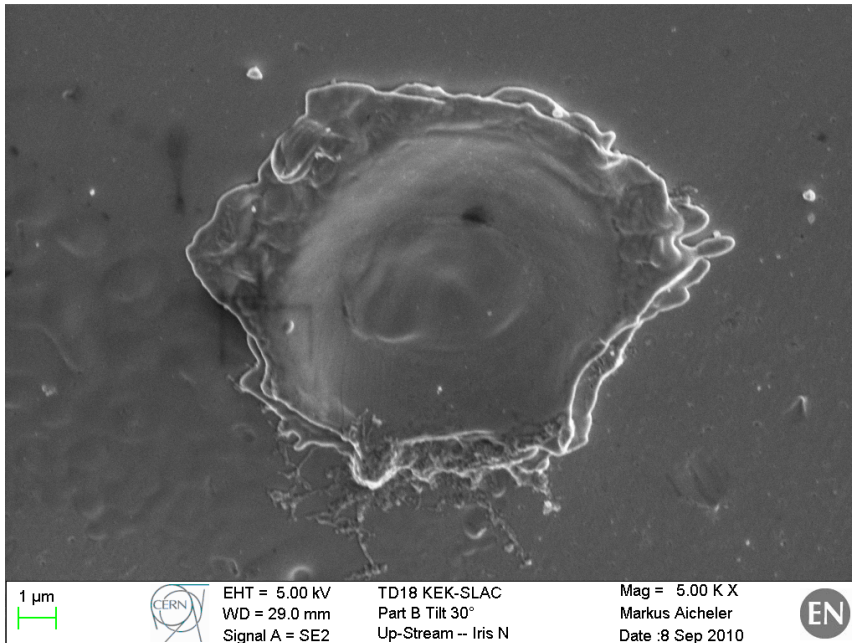

Fig. 1. SEM picture showing damage from RF breakdown

High gradient accelerating structures are typically run in a regime where breakdowns, a field emission runaway condition, occur periodically. The breakdown phenomenon is extremely complex and is being actively studied. Local heatup occurs, caused by a combination of high current density in the vicinity of the emission sites, surface defects and neutrals emitted from surface cracks, the emission process becomes more and more thermionic. As the temperature increases further, ions and neutral atoms get emitted from the bulk material and a buildup of hot plasma of electrons and ions in various charge states ensues. Space charge effects, which before limited the current density, are getting neutralized by the free ions allowing the current density to rise by orders of magnitude, enough for the breakdown to melt and evaporate material on the surface (see e.g. [2] for a basic description), leading to local damages (Fig. 1).

Different from multipacting and dark current effects, breakdown is a highly non linear and stochastic, not systematically reproducible process. Seen from a macroscopic perspective, lots of variables are influencing it in high power RF structures. Apart from the properties governing the field emission as material, field gradient and surface roughness also factors like the local magnetic field, temperature and dynamic temperature play a role. Diffusion of impurities and the amount of grain defects influence the rate, with which breakdowns occur.

There is a long history of empirical models trying to explain breakdown limits and rates as the function of various parameters. Early models concentrated on the surface electrical field, which is defined by the structure geometry and the machining quality/surface roughness causing a local, microscopic field enhancement. Scaling down structures geometrically, that way raising the operating frequency, was supposed to allow higher gradients [3,4]. Pulse surface heating – the temperature in a layer of few tens of nanometer at the conductor surface can rise by up to 50 degrees during the typical RF pulse creating mechanical stress – was empirically proven to be an important criterion (for experimental results see e.g. [5,6]). While giving already important design principles, this approach does not fully predict structure performance. It looked like the frequency dependency slowly vanished above 12 GHz, also, group velocities and bandwidths inside such a structure seemed to play an important role. To address these and also inspired by better physical explanations of the breakdown process, other heuristics were introduced normalizing the power flux with typical structures dimensions or using values of a pseudo Poynting vector on the surface as a relevant parameter [7].

While being inspired by physics, these are not true quantitative physical models. Specifically material properties like purity, grain size and the long term diffusion of defects in the lattice are not accounted for, but empirically known to have important effects. Trying to put all this on a firm footing, a collaboration between the Institute of Physics at Helsinki University (HIP) and CERN is in the process of developing a set of codes to comprehensively model all this. Molecular dynamics codes are used to model atomic processes inside the bulk material and special particle in cell codes cover the interaction between electromagnetic fields and particles as well as collision and ionization processes between the particle families (electrons, ions, neutral atoms) in free space [8-17]. First results were able to reproduce basic features of the break down process, but more work is needed.

In parallel there has been work on DC break down effects. While not completely replicating the physics of RF breakdowns, there are multiple advantages: Test setups are simpler and testing cycles take relatively short time. In addition, the DC setup is accessible to instrumentation for basic breakdown research like plasma spectroscopy, it is easy to measure temperature dependencies, the electrical characteristics of the arc and to do a fast post mortem SEM analysis

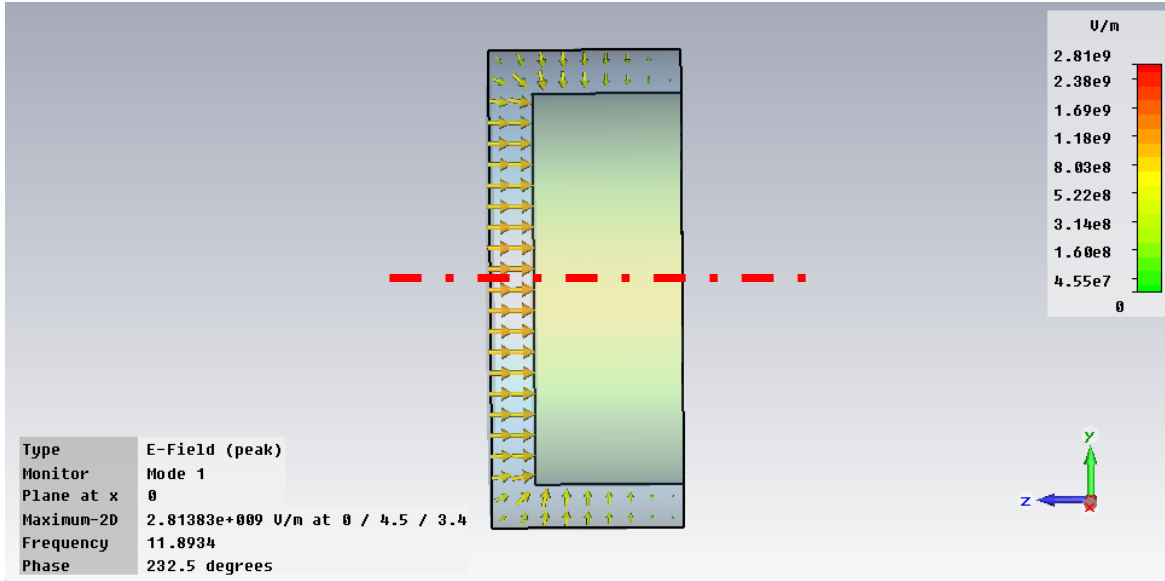

Fig. 2. Cylindrical multipactor resonator showing electric field of driven mode

of the sample surfaces. It allows the ranking a multitude of surface and material preparation techniques which are not yet covered by theoretical predictions and the setups are more easily replicated in the computational effort mentioned above and so are very important for validation. In the last years, an effort was made at CERN to benchmark the DC setup to RF structure tests in order to understand similarities and differences between breakdowns in both environments [18]. The experience gained from the DC breakdown tests seems to be well applicable to RF discharges.

PROBING ELECTRON DENSITY IN HIGH FIELD RESONATORS

The classical signature of free charges in accelerating structures is given by the reflection and transmission of the fundamental drive power. Whereas multipacting is not a typical effect in high gradient cavities, field emission and the associated dark current, is and shows up in a reduced transmission through the travelling wave structure. A breakdown with its concomitant formation of plasma will show up as a fluctuation in reflected power, while the transmission goes to zero. This is acceptable for applications like high power RF processing but not sufficient for a detailed study, since this contains only information on the location and distribution of the free electrons in the structure.

For a first experiment, we concentrate only on measuring free electrons. The idea is to have a single-cell standing-wave cavity driven at kW range power levels, which would be consistent with CW operation. The space charge in the gap is created by designing the cavity gap to exhibit two point multipactor at nominal levels. As a material, aluminum is a very good choice; having simultaneously relatively good electric conductivity and a high secondary electron yield of approximately two [19]. In addition to the fundamental power driving the multipacting process, probe signals can be injected. Apart from measuring the simple linear transmission of the probe signals, interesting alternatives are to look at intermodulation effects, either between different probe signal frequencies or between probe and fundamental frequency, or to magnetize the breakdown plasma inside the structure with an external magnetostatic field.

Table 1. Typical dimensions and RF parameters of the resonator.

Cell Length	Cell Radius	Spark Gap Radius	Spark Gap	Freq	Quality factor	Power	Acc. Field
L_{cell} [mm]	R_{cell} [mm]	R_{gap} [mm]	g [mm]	F [GHz]	Q	P_{loss} [kW]	E_0 [MV/m]
4.4	5.5	4.5	1	11.9	1280	2	8.6

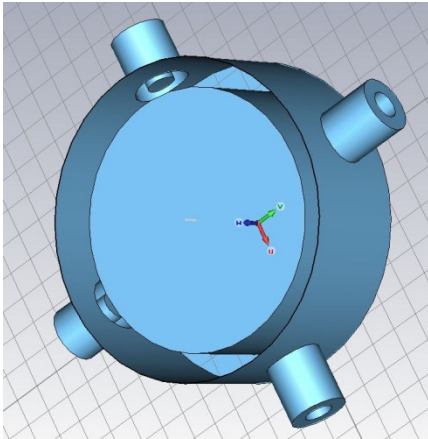

Fig. 3. Generic layout with coaxial couplers

Fig. 2 shows the basic layout of such a cavity designed for multipactor. Features like vacuum pumping, RF couplers and cooling are not shown. The mode driven by external power is the fundamental TM mode giving a maximum in the electric field in the center of the cavity, where we want to drive a multipacting process. According to [19], Aluminum has its peak value in secondary electron yield for electron energies of roughly 400 eV, where each electron impact will produce two secondaries. An analytical two plate resonator model as in [20] gives us a required electrical field gradient of 2.55 MV/m for a driving frequency of 12 GHz. Creating two point multipactor of the lowest order $N=1$ requires, that the width of the gap equals the distance, an emitted electron travels within an RF half period. This would result in a gap size of 250 μm , which would create problem with vacuum pumping. A feasible design should go for a multipacting order of $N=3$ or 5 resulting in a corresponding larger gap.

Table 1 shows typical dimensions and the electrical parameters of the resonator. The required electrical gradient can be reached with a few hundred Watts of drive power, which means that, with appropriate cooling, one may be able to do measurements in CW (or at least work using relatively long RF pulses.).

Fig. 4. Electric field of lowest dipole and quadrupole mode

Drive and probe signals could be coupled in coaxially at the outer cavity radius as indicated in Fig. 3. Having four couplers at a 90 degree angle will allow to excite the fundamental monopole mode as well as couple to both polarizations of the dipole modes and to one of the quadrupole modes (Fig. 4).

The free electrons are created by driving the fundamental TM mode and creating the necessary multipactor conditions in the spark gap. To measure the multipactor discharge, we have multiple options:

- Start in a classical way by monitoring the match of the fundamental drive power.
- Probe it via a passive measurement of the dipole or quadrupolar modes. With a high probability, the nonlinearity of the multipactor will feed energy into these resonances, so that one may see already signals that way. Apart from the amplitude of the discharge itself, the signal will depend on its location. The discharge needs to be asymmetric and will couple strongest, where the multipole modes have their electric field maxima.

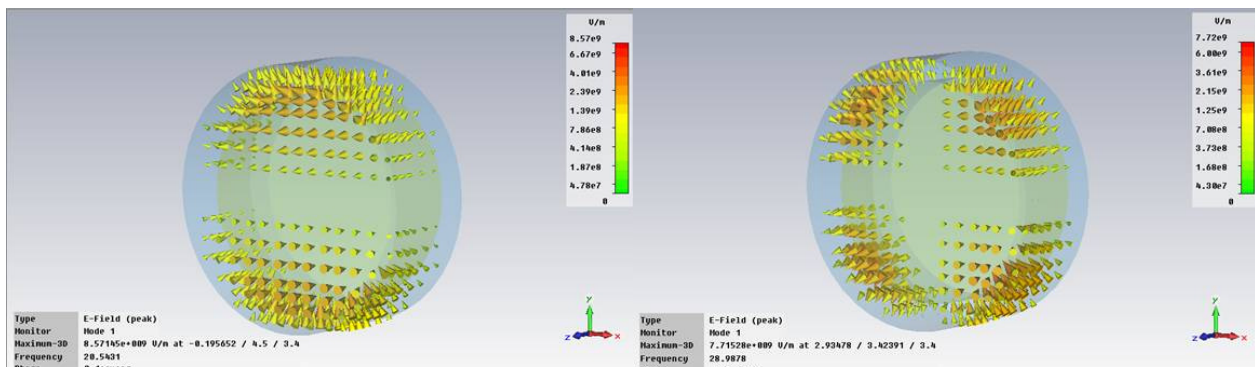
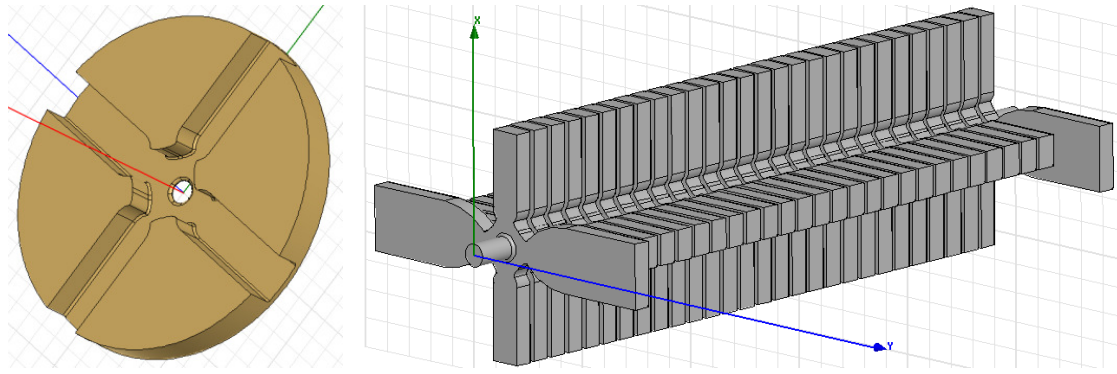

Fig. 4. Electric field of lowest dipole and quadrupole mode



• A

Fig. 5. Individual resonator disk with radial high order mode coupler (left) and full accelerator structure built from multiple resonators (right)

more systematic way is to excite the multipole modes with probe signals and measure the shift and width of the resonances. An interesting case is the measurement of the cross talk between the two different polarized dipole modes. Assuming ideal symmetry, it should be zero and any asymmetries in the discharge should be clearly visible in the signal.

- Furthermore magnetostatic fields could be applied during the measurement. Apart from influencing multipactor levels, the magnetized electron cloud starts to exhibit non reciprocity, a property, which would also show up in the transmission between the coupling ports.
- A last, slightly dangerous, variant is to increase the power and drive the resonator into a plasma type RF discharge. The goal would be to measure the transition from the field emission regime into a plasma discharge. The clear disadvantage is, that this is a destructive measurement, the measurement would have to be done with short, high power RF pulses. None the less the surface in the spark gap will degrade over time.

Talking about similarities and differences of effects in typical microwave circuits and accelerating structures, we can compare the setup used in [21] with our proposal here. The most significant difference is, that we are having a test structure with lots of different narrow resonances. While this does not make a difference in terms of the fundamental frequency, there may be subtle differences, if we think about the (fractional) harmonics showing up in the discharge current. Where in [21], the higher harmonics in the discharge see a rather flat (and for high frequencies resistive) impedance, the location of the upper resonances with respect to the harmonics may produce strongly varying impedance peaks. This may influence strongly the flux of energy between the fundamental, the electron cloud and the higher order modes, and in turn affect the discharge mechanism. This interaction is an interesting topic to understand in the numerical simulation.

How can results from the basic single cell cavity transferred to the real RF accelerator structure? As can be seen in Fig. 5, the resonator design of the CLIC structure [22] contains several coupling holes used to damp secondary resonances. These offer the interesting option to inject probe signals at a frequency different from the fundamental into the structure. Also transmission from cell to cell over a segment of the structure can be realized that way. The pattern of transmission through the structure will indicate the location and extent of the breakdown.

SUMMARY

Vacuum discharge effects as multipacting and dark current effects are purely based on the flux of free electrons. More complex is the mechanism for RF breakdowns, which is a true multi physics phenomenon being determined by field emission, ionization effects, the macroscopic power flux and crystal structure and diffusion in the bulk material. A detailed analysis and understanding is a critically important condition for the design of high performance RF accelerating structures. In the context of the CLIC project at CERN, a set of DC and RF based breakdown experiments is under way complemented by a large multi physics simulation effort designed to have an in depth view of the problem. To profit from the large experience accumulated in designing transmitter systems in satellite communications, we are proposing an evaluative experiment, which offers a wide variety of measurements. Combined with the modelling of the electron dynamics during discharge, this will be an important step in evaluating the possible development of in situ diagnostics for the standard accelerating structures in CLIC. Work is under way for a fully featured electrical design including couplers and vacuum pumping ports.

REFERENCES

- [1] Fowler, R.H.; Dr. L. Nordheim (1928-05-01). "Electron Emission in Intense Electric Fields", *Proceedings of the Royal Society of London* 119 (781): 173–181.
- [2] Zeke Insepov, Jim Norem, Thomas Proslie, Dazhang Huang, Sudhakar Mahalingam, Seth Veitzer, "Modeling rf breakdown arcs", *proc. PAC09*, Vancouver, BC, Canada, TU5PLP001 (2009)
- [3] W. D. Kilpatrick, "Criterion for Vacuum Sparking Designed to Include Both rf and dc", *Rev. Sci. Instrum.* **28**, p.824 (1957); DOI:10.1063/1.1715731.
- [4] T. J. Boyd, Jr., "Kilpatrick's criterion", *Los Alamos Group AT-1 report* AT-1:82-28, February 12, 1982
- [5] M. Aicheler, "Surface phenomena associated with thermal cycling of copper and their impact on the service life of particle accelerator structures," CERN-THESIS-2010-189.
- [6] L. Laurent, S. Tantawi, V. Dolgashev, C. Nantista, Y. Higashi, M. Aicheler, S. Heikkinen, W. Wuensch, "Experimental study of rf pulsed heating," *Phys. Rev. ST-AB*, 041001 (2011)
- [7] A. Grudiev, S. Calatroni, and W. Wuensch, "New local field quantity describing the high gradient limit of accelerating", *Phys. Rev. ST Accel. Beams* 12, 102001 (2009).
- [8] Rod Latham, "High Voltage Vacuum Insulation", Academic Press, ISBN 0-12-437175-2 (1995).[9] H. Timko, F. Djurabekova, K. Nordlund, L. Costelle, K. Matyash, R. Schneider, A. Toerklep, G. Arnau-Izquierdo, A. Descoeudres, S. Calatroni, M. Taborelli, and W. Wuensch, "Mechanism of surface modification in the plasma-surface interaction in electrical arcs", *Phys. Rev. B* 81 (2010)184109.
- [10] S. Parviainen, F. Djurabekova, A. Pohjonen, and K. Nordlund, "Molecular dynamics simulations of nanoscale metal tips under electric fields", *Nuclear Instruments and Methods in Physics Research Section B: Beam Interactions with Materials and Atoms*, in press.
- [11] A. Pohjonen, F. Djurabekova, A. Kuronen, K. Nordlund, and S. Fitzgerald, "Dislocation nucleation from near surface void under static tensile stress on surface in Cu", unpublished.
- [12] S. Calatroni, A. Descoeudres, J. W. Kovermann, M. Taborelli, H. Timko, W. Wuensch, F. Djurabekova, K. Nordlund, A. Pohjonen, and A. Kuronen, "Breakdown studies for the CLIC accelerating structures", *Proceedings of 2010 LINAC conference*, number MOP070, 2010.
- [13] F. Djurabekova, S. Parviainen, A. Pohjonen, and K. Nordlund, "Atomistic modeling of metal surfaces under electric fields: Direct coupling of electric fields to a molecular dynamics algorithm", *Phys. Rev. E* 83 (2011) 026704, Combined electro-dynamics-molecular dynamics model in PAR-CAS. 1
- [14] F. Djurabekova, J. Samela, H. Timko, K. Nordlund, S. Calatroni, M. Taborelli, and W. Wuensch, Crater formation by single ions, cluster ions and ion showers", *Nuclear Instruments and Methods in Physics Research Section B: Beam Interactions with Materials and Atoms*, in press.
- [15] S. Parviainen, F. Djurabekova, H. Timko, and K. Nordlund, "Electronic processes in molecular dynamics simulations of nanoscale metal tips under electric fields", *Computational Materials Science* In Press, in press.
- [16] H. Timko, K. Matyash, R. Schneider, F. Djurabekova, K. Nordlund, A. Hansen, A. Descoeudres, J. Kovermann, A. Grudiev, W. Wuensch, S. Calatroni, and M. Taborelli, "A One-Dimensional Particle-in-Cell Model of Plasma Build-Up in Vacuum Arcs", *Contrib. Plasma Phys.* 51 (2011) 5.
- [17] H. Timko, "2D Arc-PIC code description: methods and documentation", CLIC Note XXX, European Organization for Nuclear Research (CERN), 2011, unpublished.
- [18] Jan Kovermann, "Comparative Studies of High-Gradient Rf and Dc Breakdowns", CERN-THESIS-2010-196
- [19] Y. Lin and D.C. Joy, "A new examination of secondary electron yield data", *Surf. Interface Anal.* 2005; 37: 895-900
- [20] E. Sorolla et al., "An Analytical Model to Evaluate the Radiated Power Spectrum of a Multipactor Discharge in a Parallel Plate Region", *IEEE trans. Electron Devices*, Vol. 55, No. 8, pp 2252-2255, August 2008
- [21] M Jiménez, B Gimeno, C Miquel-Espanya, D Raboso, S Anza, C Vicente, J Gil, F Quesada, A Álvarez, M Taroncher, M Reglero and V E Boria, "Analysis of the electromagnetic radiation generated by a multipactor discharge occurring within a microwave passive component", *J. Phys. D: Appl. Phys.* 43 (2010) 395501
- [22] A. Grudiev, W. Wuensch, "Design of the CLIC Main Linac Accelerating Structure for CLIC Conceptual Design Report", *proc Linear Accelerator Conference LINAC2010*, Tsukuba, Japan, MOP068 (2010)