



European Coordination for Accelerator Research and Development

PUBLICATION

UA9 Status Report

Scandale, W (IN2P3)

25 April 2012

The research leading to these results has received funding from the European Commission under the FP7 Research Infrastructures project EuCARD, grant agreement no. 227579.

This work is part of EuCARD Work Package 4: **AccNet: Accelerator Science Networks**.

The electronic version of this EuCARD Publication is available via the EuCARD web site <<http://cern.ch/eucard>> or on the CERN Document Server at the following URL :
<<http://cdsweb.cern.ch/record/1443849>>

UA9 Status Report

Walter Scandale, IN2P3

April 2012

Recent experimental findings

In the last couple of years, a particular effort was made to evaluate the potential benefit of using primary bent crystals with low torsion installed in a better performing goniometer build at IHEP (Protvino, Russia), three times more accurate than the ones used up to 2009. The investigation was extended to the loss profile using a movable limiting aperture target installed in the high-dispersive area downstream of the crystal-absorber, by which the population of the off-momentum particles produced in the collimation process could be evaluated. The quick overview of the 2010 results sketched in [1] was complemented by [2]. Two issues should be highlighted:

1. The beam loss rate detected by beam loss monitors (BLM) close to the crystal was reduced by a factor about six in channeling orientation with respect to amorphous orientation. Such a reduction factor was larger than in 2009 data reported in [3] but still considerably smaller than the predicted value. By this result, one could exclude significant contribution of residual crystal torsion to the discrepancy between simulation and experimental results since in the new crystals the torsion was significantly smaller than the critical angle.
2. The off-momentum fraction of beam halo particles escaping from the collimation area was estimated by using the scraper of the TAL52196 station, shown in Fig 1. During the scans made from the garage position to the location of the crystal edge projection the scraper intersects the off-momentum halo and secondary particles generated in the scraper were detected by the BLM downstream. Off-momentum halo population observed for channeling orientation of the crystal was reduced few times in comparison with its amorphous orientation.

A description of the UA9 layout is given in Ref [4].

Crystal collimation of Pb ion beam

At the end of 2010, experiments on the crystal collimation were performed also with a Pb ion stored beam of 120 GeV/c per charge. The scattering induced by inner electric field of crystals depends on the ratio p/Z between the momentum and the charge of the incident particles.

The crystal channeling characteristics are thus the same for protons and Pb ions of the same momentum per charge. However, Pb ions produce larger ionization losses and nuclear interaction rate in the crystal, because of the much larger cross-sections with respect to protons. In our 2 mm long silicon crystals in amorphous orientation the mean energy loss for Pb ions exceeds 6 GeV. In these conditions, three passages of Pb ions through the nonaligned crystal should be on average sufficient to extract the particle from its RF-bucket. This induces a considerable increase of the oscillation amplitude in the dispersive regions of the accelerator. On the other hand, the total cross section of Pb ion beam attenuation in silicon, which includes inelastic nuclear interactions and electromagnetic dissociation, is 10 times larger than for protons, $\sigma_{\text{tot}} = 5.414$ b. The attenuation length equals 3.76 cm. Therefore more than 5% of Pb ions will be lost per passage through the non-aligned crystal.

Curve 1 in Figs. 2(a) and (b) shows the Pb ion beam losses as function of the orientation angle for crystal 3 (a) and crystal 4 (b). In the same Figs., the simulation results for the number of Pb ion inelastic interactions in the crystals are shown by curve 2. With crystal 3 the beam halo losses were reduced by about 60% in channeling conditions that is a loss reduction factor $R_{\text{in}} \approx 2.5$. The value of R_{in} is considerably smaller for Pb ions than for protons. This is caused by a considerably larger average energy loss in the interaction with the crystal in amorphous orientations that induces larger transverse oscillations to Pb ions trajectories. As a result, Pb ions reach more quickly the TAL, after a smaller number of crystal traversal. The loss profile as a function of the crystal angle is thus flattened with respect to the case of protons.

Although crystal 3 and crystal 4 were used in similar configurations for halo extraction, the beam loss reduction in channeling conditions for crystal 4 was $R_{\text{in}} \approx 3.5$, thus larger than for crystal 3. The distances from the orbit of crystal 3 and of the TAL were $X_{\text{CR3}} = 5.8$ mm ($5.7\sigma_x$) and $X_{\text{TAL}} = 10.4$ mm ($9.3\sigma_x$), respectively, whilst the distances from the orbit of crystal 4 and the TAL were $X_{\text{CR3}} = 3$ mm (about $3\sigma_x$) and $X_{\text{TAL}} = 7.9$ mm ($6.7\sigma_x$). To explain the different behavior of the two crystals we use the following argument. The deflecting planes are (110) for crystal 3 and (111) for crystal 4. The latter are non-equidistant. The channel width ratio is 3. The width of narrow channels is about 2.5 times smaller than for the (110) channels. Particles quickly dechannel from these narrow channels increasing the probability of inelastic interactions with the crystal nuclei. So, according to simulations, the probability of nuclear interactions in a single passage for parallel beam is 20% larger for crystal 3 than for crystal 4 with its (110) equidistant planes.

The loss reduction factors for perfect crystal alignment obtained in our simulations are $R_{\text{in}} = 8.3$ and 14.2 for crystal 3 and 4, respectively. The discrepancy with the data may be caused by

the residual cutting-error angle between the crystal surface and the crystallographic planes appearing as a result of the crystal sample production from a silicon ingot. In the case of a crystal with a large cutting error a halo particle with a small impact parameter should have the first encounter with the lateral face of the crystal where its momentum direction is far from the crystal plane direction. Passing through a large part of the crystal length the particle is deflected by multiple Coulomb scattering and only on the following turns it hits the front face of the crystal where it may be captured into channeling and extracted from the circulated beam. The first passage through the crystal as in amorphous substance increases the probability of inelastic nuclear interactions for this halo fraction. This point is still under investigation.

The Pb ion beam halo fraction deflected due to channeling by the crystal 3 was measured by intersecting the deflected beam with the LHC prototype collimator as was done in the case of the proton beam collimation [3]. Its value was found to be 74%, a value very close to that of protons.

Off-momentum halo dependence on the crystal orientation

Collimation leakage is formed by far off-momentum particles generated in the crystal and in the absorber, which, in the dispersion suppressor regions of the SPS, travel more and more deeply inside the absorber shadow. In a recent experimental run, the bottom of Roman pot in the high-dispersive area (RP3) was used to study the off-momentum halo. The bottom length along the beam and its transverse thickness are 30 mm and 0.8 mm, respectively. So, it was possible to monitor the local density of the halo when the RP bottom was placed at some distance inside the absorber shadow.

Fig.3 shows the beam loss dependencies on the orientation angle of the crystal 4 detected with the scintillation telescopes downstream the crystal (a) and in the high-dispersive area downstream of the Roman pot 3 (b). The roman pot in this case was placed at the distance about 2-3 mm inside the absorber shadow. It is clearly seen a strong correlation between two dependencies. When the crystal orientation is close to a perfect alignment with the beam envelope a large part of the beam halo is deflected in channeling states at the first or subsequent passages through the crystal and hit the absorber. These particles avoid inelastic nuclear interactions in the crystal that causes a deep minimum of beam losses detected by the telescope behind the crystal. Elastic nuclear interactions were also avoided by channeled particles. This causes a strong reduction of the off-momentum halo population detected in the high-dispersive area. For the considered case the loss reduction behind the crystal is about 9 while the off-momentum halo reduction in the HD area is about 5. A smaller reduction of the off-momentum halo population in the HD area may be caused by some additional production of off-momentum particles in the absorber. Anyhow we had preliminary indications that the off-momentum halo

reduction was increased approaching to the loss reduction in the crystal when the RP3 was placed deeply inside the absorber shadow.

Very recently we could substantially increase the proton stored intensity up to 5×10^{12} particles and reduce the beam lifetime down to 1 to 5 h. In these conditions we could collect preliminary loss maps around the whole ring during the angular scan of the crystal. The indication is that also in the other sextant of the SPS the beam loss are reduced when the crystal is in channeling orientation with respect to its amorphous orientation, as shown in Fig. 4. This observation holds in dispersive and in non-dispersive locations.

Conclusions

The UA9 experiments performed in the last year with protons and Pb ions at 120 GeV/c momentum per charge allow drawing the following conclusions.

1. In the case of Pb ions the beam halo can be efficiently deflected onto the secondary collimator-absorber with a bent crystal. It is important to perform a study of the crystal radiation resistance with high-energy heavy ion beams to better estimate the possibility of using a crystal primary collimator for the LHC ion beams. The smaller loss reduction for Pb ions, compared to protons, is caused by their larger ionization losses. As a result, their oscillation amplitudes increase considerably in the passages through the nonaligned crystal and bring them more quickly into the absorber.
2. There is a strong correlation between the reduction of the beam losses in the crystal and off-momentum halo population in channeling condition because of the suppression of both inelastic and elastic nuclear interactions for channeled particles in the crystal. Collimation efficiency should be increased whilst collimation leakage should be reduced with increasing channeling efficiency of the crystal primary collimator.
3. Loss maps around the SPS have given preliminary indications that the crystal in channeling orientation produces a smaller background rate than in its amorphous orientation in all the ring locations.

Crucial items for this exceptional performance are the high repeatability goniometer and the high quality low torsion crystal used as primary deflector of the halo particles.

List of seminars and workshops

15 April 2010 Seminar at Imperial College by W. Scandale

14 September 2010 Seminar at Roma University “La Sapienza” by W. Scandale

7 October 2010 Invited talk by W. Scandale at the conference “Channeling 2010”

2 November 2010 seminar at SLAC by U. Wienands

6 September 2011 Invited talk by W. Scandale at IPAC 11.

19 October 2011 invited talk at INP by W. Scandale

2 November 2011 invited talk of U. Wienands at the [LARP-CM15 workshop](#)

17 May 2011 invited talk by V. Previtalli at the [LARP-CM16 workshop](#)

6 February 2012 [Meeting on UA9 goniometer](#)

18-20 April 2012 [UA9 Meeting at CERN](#)

References

[1] UA9 status report for 2010, CERN-SPSC-2011-037/SPSC-SR-092.

[2] W. Scandale et al, Phys.Letters B 703 (2011) 547.

[3] W. Scandale et al, Phys.Letters B 692 (2010) 78.

[4] W. Scandale et al, 2011 JINST 6 T10002 [doi:10.1088/1748-0221/6/10/T10002](https://doi.org/10.1088/1748-0221/6/10/T10002) The UA9 experimental layout

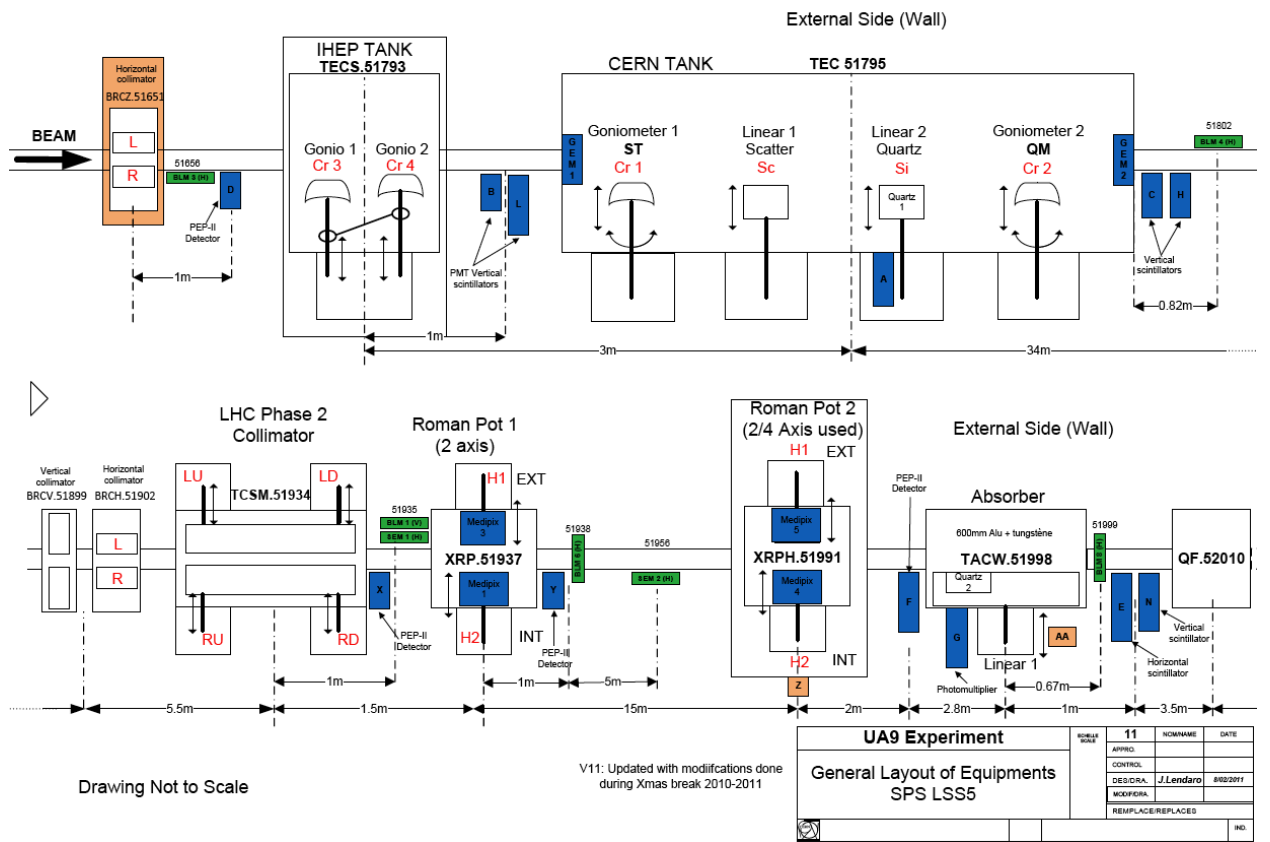
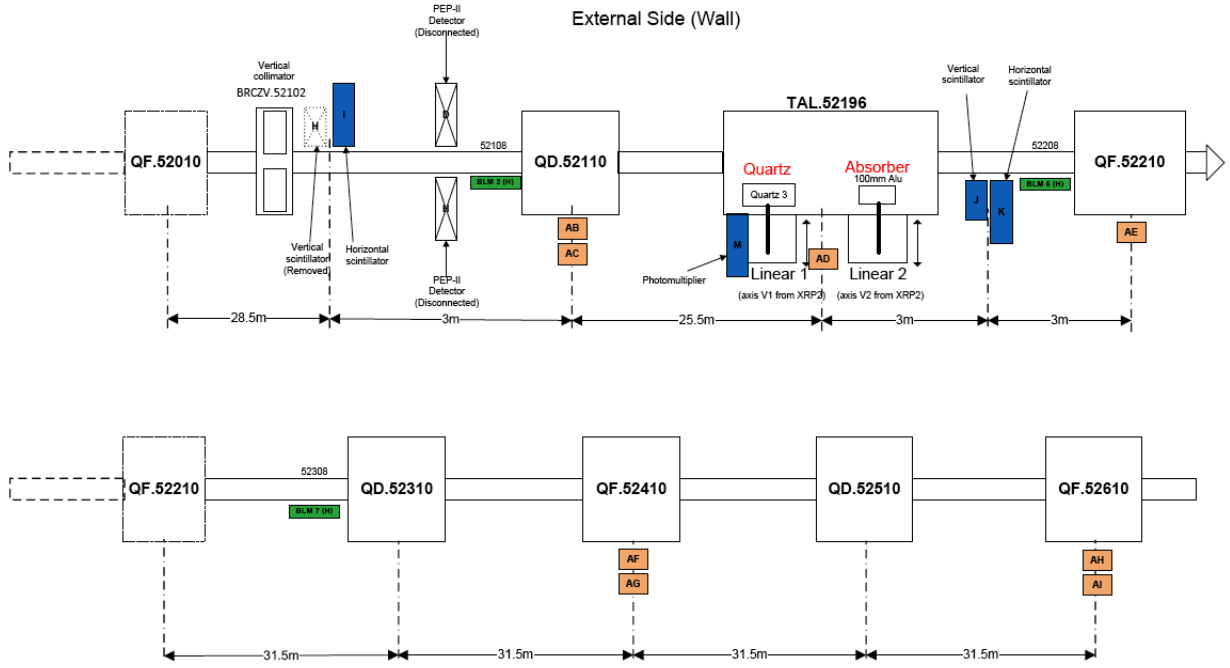

Fig.1. a) Layout of crystal-collimator area of UA9.



Drawing Not to Scale

Fig 1.b) Layout of the dispersive region of UA9.

UA9 Experiment		REVISE	11	HCNNAME	DATE
General Layout of Equipments		APPRO.			
SPS LSS5		CONTROL			
		DESIGNER	J.Lendaro		09/02/11
		MODIFIER			
		REPLACE/REPLACES			
					IND.

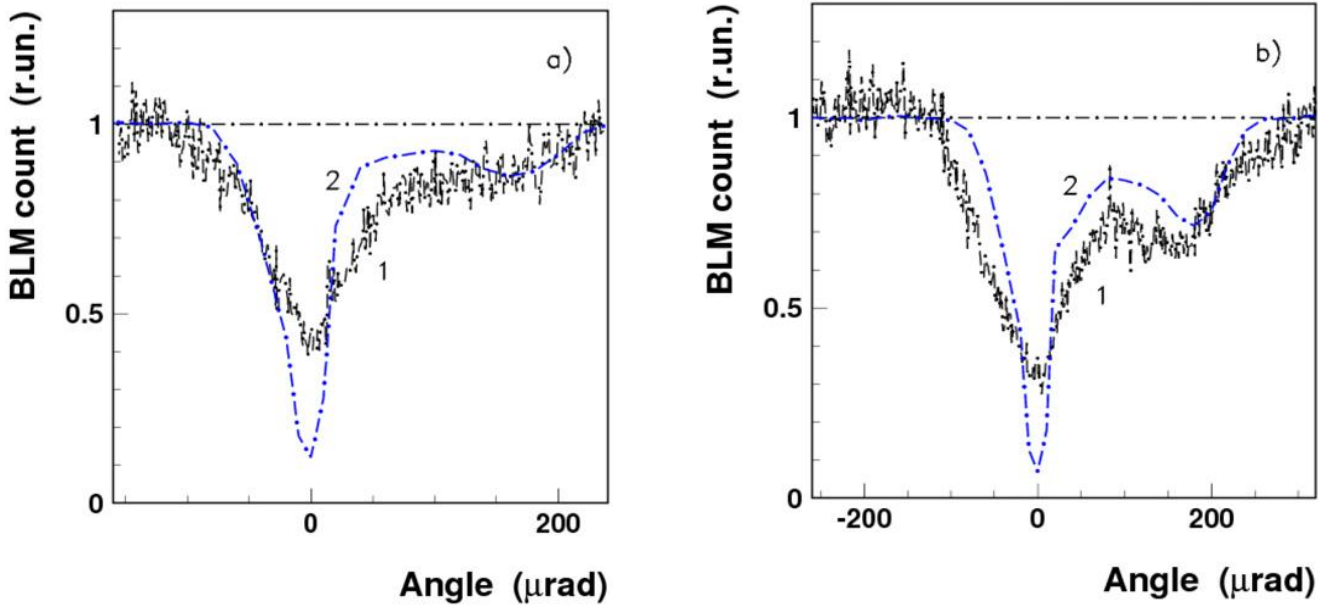

Fig.2. Pb ion beam collimation. (1) The dependences of the beam loss monitor signal on the angular position of the crystal 3 (a) and 4 (b) normalized to its value for the amorphous orientation of the crystal (dot-dashed line). (2) The simulation results for the number of inelastic nuclear interactions in the crystals.

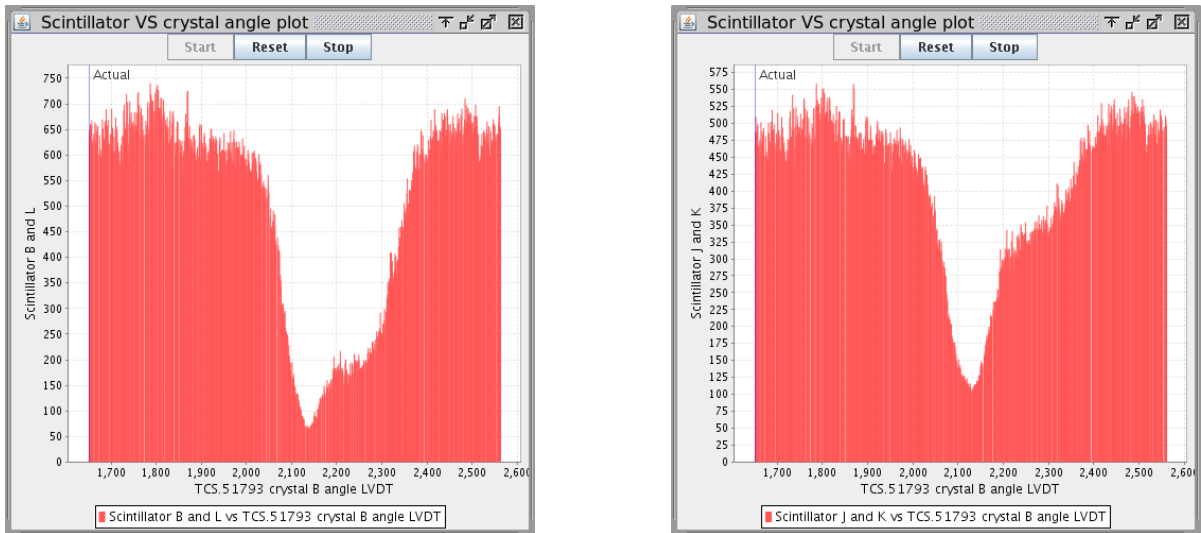
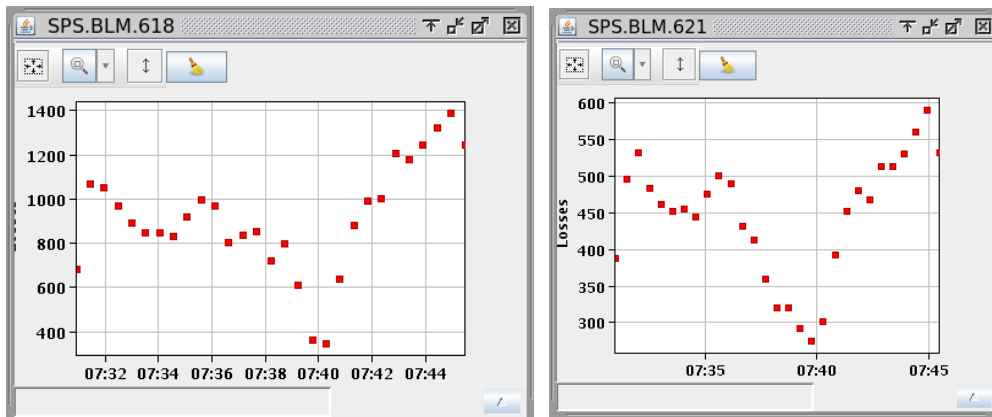
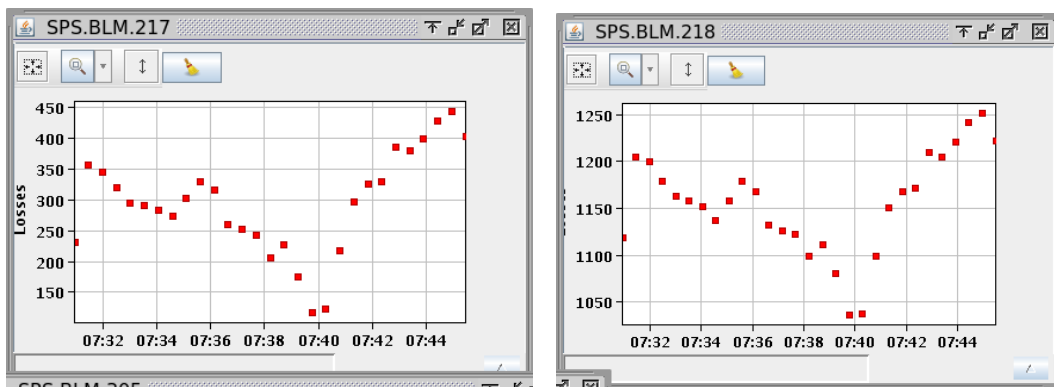

Fig.3. Beam loss dependencies on the orientation angle of the crystal 4 detected with the scintillation telescopes downstream the crystal (a) and in the high-dispersive area downstream of the collimator-absorber (b).



a) Loss in the long straight section of Sextant 6 in location with large horizontal β -function and very small dispersion.



b) Loss in the long straight section of Sextant 6 in location with large horizontal β -function and very small dispersion.

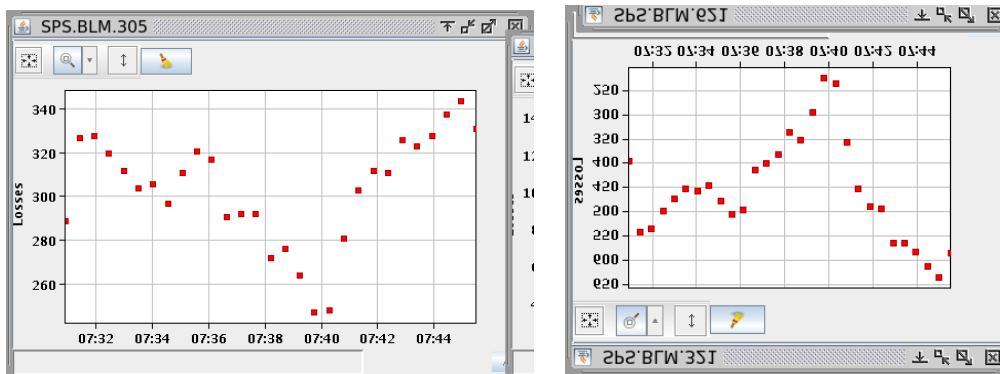

c) Loss in the in the arc and in the dispersion suppressor of Sextant 3 in locations with large vertical β -function and large dispersion.

Fig.4. Beam loss variations during the angular scan of the crystal 4 detected with the standard SPS beam loss monitors in some selected positions of the SPS ring.