



European Coordination for Accelerator Research and Development

PUBLICATION

Modified SRF Photoinjector for the ELBE at HZDR

Murcek, P (HZDR) *et al*

02 April 2012

The research leading to these results has received funding from the European Commission under the FP7 Research Infrastructures project EuCARD, grant agreement no. 227579.

This work is part of EuCARD Work Package **10: SC RF technology for higher intensity proton accelerators and higher energy electron linacs.**

The electronic version of this EuCARD Publication is available via the EuCARD web site <<http://cern.ch/eucard>> or on the CERN Document Server at the following URL :
<<http://cdsweb.cern.ch/record/1436390>>

Modified SRF photoinjector for the ELBE at HZDR

P.Murcek^{#1}, A. Arnold¹, H. Buettig¹, P. Michel¹, J. Teichert¹ and R. Xiang¹,
P. Kneisel²,

¹Helmholtz-Zentrum Dresden-Rossendorf, Dresden, Germany

²Jefferson Lab, Newport News, VA 23606

Abstract

The superconducting radio frequency photoinjector (SRF photoinjector) with Cs₂Te cathode has been successfully operated under the collaboration of HZB, DESY, HZDR, and MBI.[1] In order to improve the gradient of the gun cavity and the beam quality, a new modified SRF gun (SRF-gun 2008) has been designed.

The main updates of the new cavity design for the new photoinjector were published before. (ID THPPO022 on the SRF09 Berlin.) This cavity is being fabricated in Jefferson Lab.

In this paper the new ideas of the further parts of the SRF-gun 2008 will be presented. The most important issue is the special design of half-cell and choke filter. The cathode cooler is also slightly changed, which simplifies the installation of the cathode cooler in the cavity.

The next update is the separation of input and output of the liquid nitrogen supply, for the purpose of the stability of the nitrogen pressure as well as the better possibility of temperature measurement.

Another key point is the implementation of the superconducting solenoid inside the cryomodule. The position of the solenoid can be accurately adjusted with two stepmotors, which are thermally isolated to the solenoid itself.

INTRODUCTION

For ELBE LINAC (E)lectron L(inear) a(ccelerator) with high

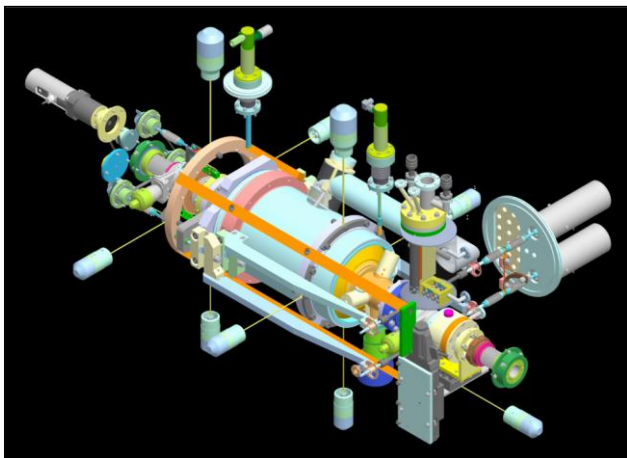

Fig. 1: View of the inside parts .

Brilliance and low Emittance) a new SRF-gun has been redesigned. (see Fig.1) This paper presents the revised design and discusses the advantages.

SPECIAL DESIGN OF HALF-CELL AND CHOKE FILTER



Fig. 2: The status of the cavity fabrication.

The Fig.2 is the latest photograph of the new cavity, which is currently produced and assembled in Jefferson Lab. There, the whole process, including production, tuning and welding in the tank will be done [2][3]:

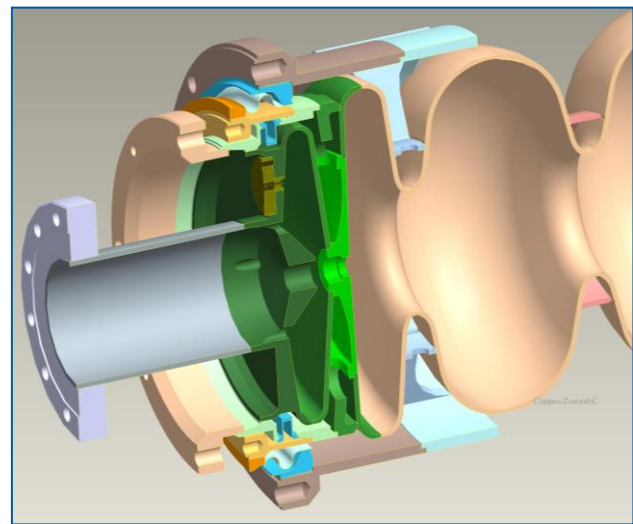

Fig. 3: New cathode opening design

- Welding of the resonator
- Etching
- Cleaning
- Cold test @ 2K
- Field profile measurement
(Details of the measurement are given in Ref. [4].)
- Passband / Choke
- Tank Welding
- Etching
- Cleaning

THE CATHODE COOLER

The cathode cooler and LN2 reservoir are slightly changed (Fig.4). It simplifies the assembly work in a clean room and prevents contamination of the cavity.

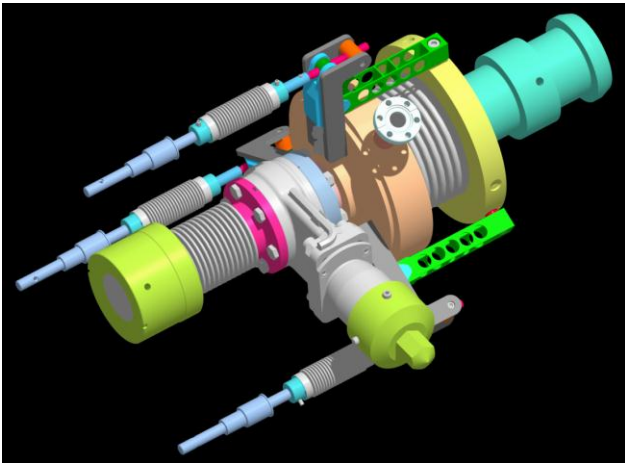

Fig. 4: 3D model of the cathode cooler.

The new cooler (Fig.5) is finished and currently tested for leaks. It is planned to be assembling with cavity in the following October.

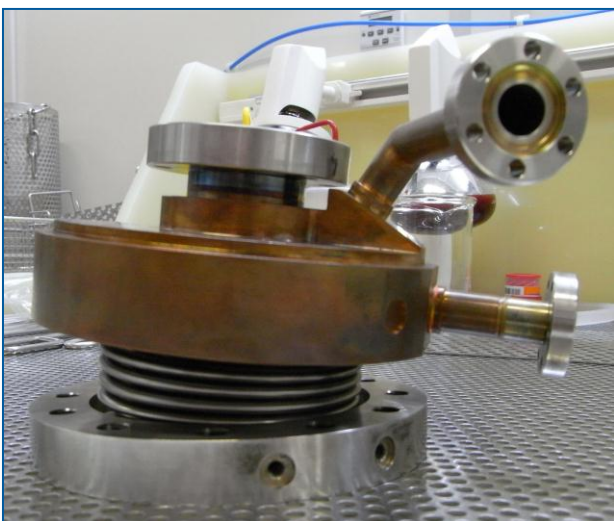

Fig. 5: New cathode cooler

SEPARATION OF INPUT AND OUTPUT OF THE LIQUID NITROGEN SUPPLY

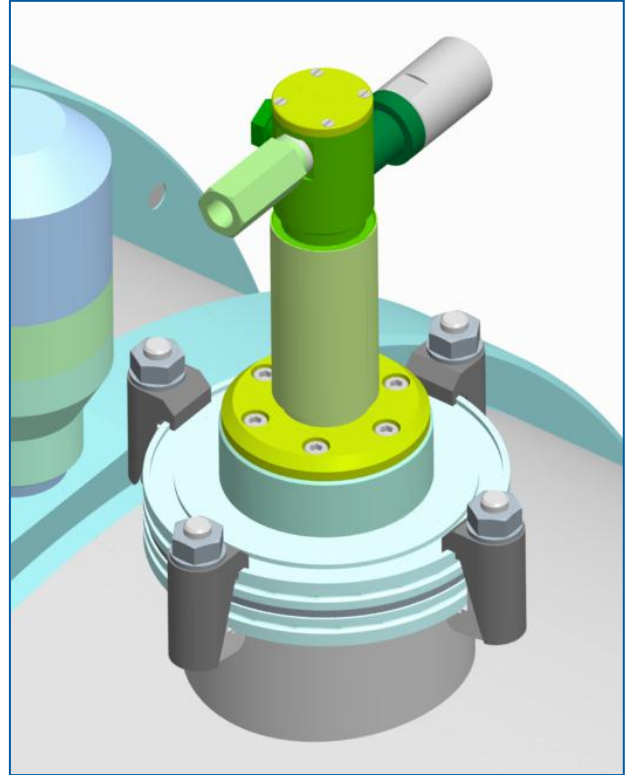

Fig. 6: Output of nitrogen supply

The next update is the separation of input and output of the liquid nitrogen supply, used for the purpose of the stability of the nitrogen pressure as well as the better possibility of temperature measurement. (Fig.6 and 7)

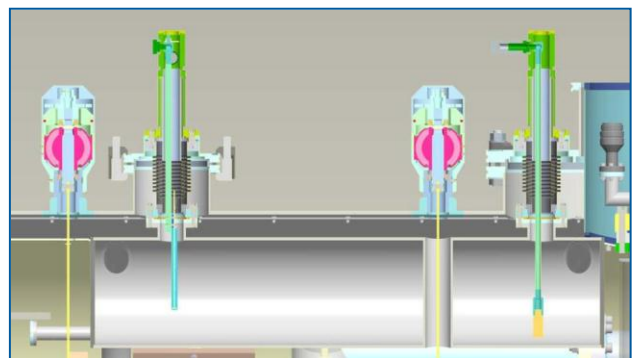

Fig. 7: Nitrogen supply with Tank

IMPLEMENTATION OF THE SUPERCONDUCTING SOLENOID INSIDE THE CRYOMODULE

In collaboration with HZB is pursued this idea: Helium-cooled superconducting solenoid is integrated into Cryomodule. Power supplies are realized through the inbuild line from helium tank.

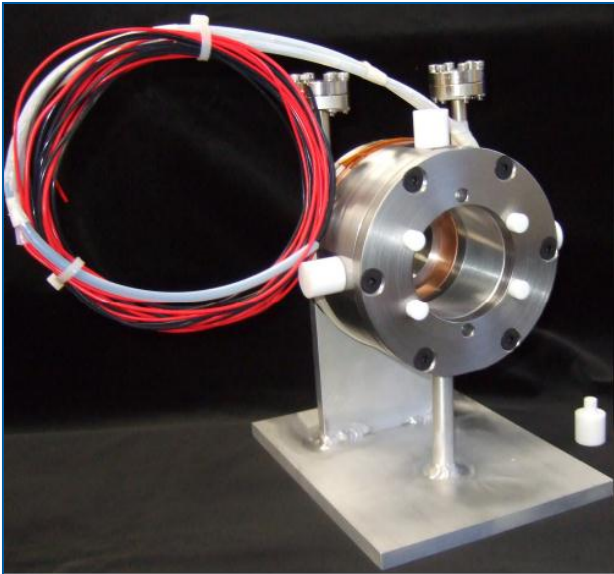

Fig. 8: The photo of solenoid

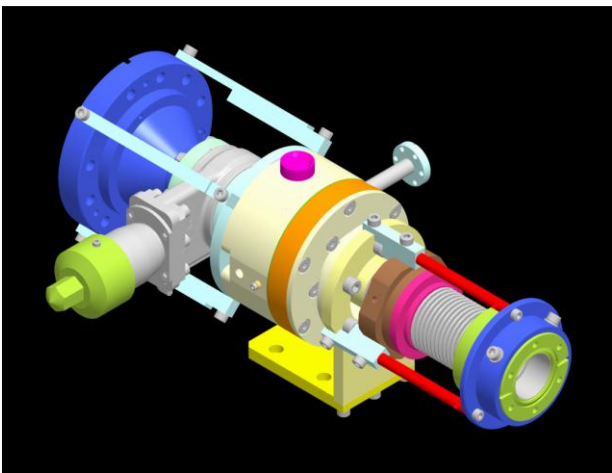

Fig. 9: completed solenoid part on the beam pipe

The position of the solenoid can be accurately adjusted with two step motors (Fig.10), which are thermally isolated to the solenoid itself.

Heat loading to the He system still must be optimized. After the calculation (Fig.11 to 13) and construction have been carried out, the practical tests will be performed.

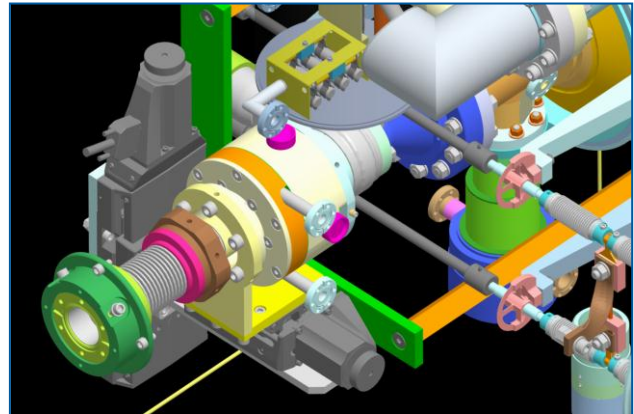

Fig. 10: Solenoid with two step motors

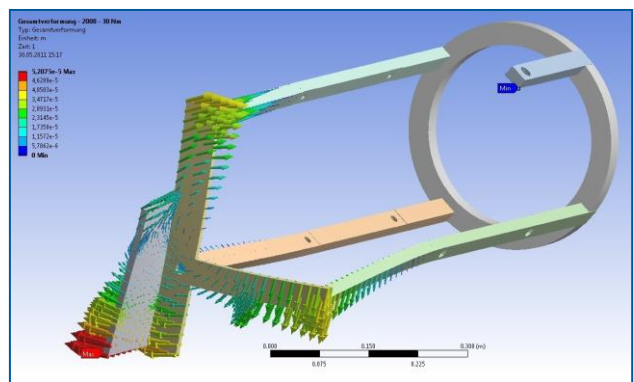

Fig. 11: Calculation of mechanical properties

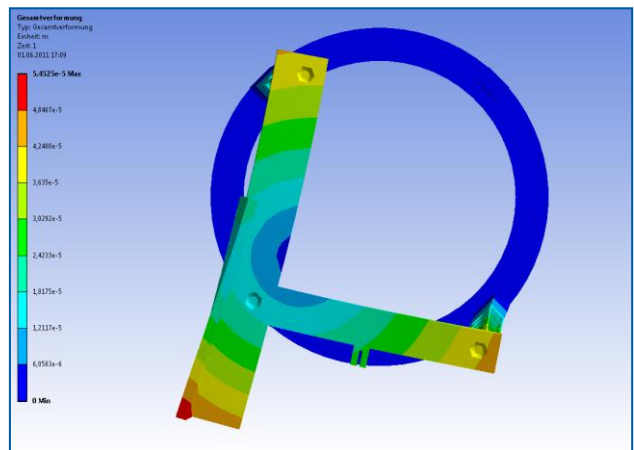

Fig. 12: Acceptable deflection

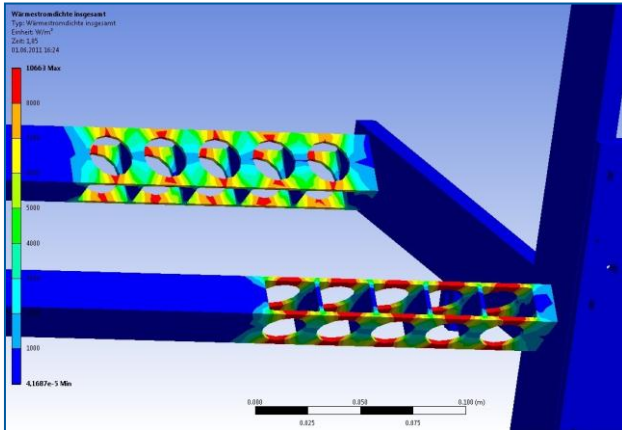

Fig. 13: Thermal calculation

REFERENCES

- [1] J. Teichert, et al, EPAC08, June 23-27, 2008, Genoa, Italy, p. 2755.A. Arnold et al., AIP Conf. Proc. 1149, 1125 (2009).
- [2] P. Kneisel, "Progress on Large Grain and Single Grain Niobium", SRF 2007, Beijing, China, paper TH102
- [3] P. Kneisel, et al, EPAC08, June 23-27, 2008, Genoa, Italy, p. 877
- [4] A. Andre, et al, SRF2011, "Fabrication, Tuning, Treatment and Testing of Two 3,5 Cell Photo-Injector Cavities for the ELBE Linac", these proceedings

ACKNOWLEDGEMENT

We acknowledge the support of the European Community-Research Infrastructure Activity under the FP7 programme (EuCARD, contract number 227579), as well as the support of the German Federal Ministry of Education and Research grant 05 ES4BR1/8.

We would like to thank all our colleagues at Jlab and Helmholtz-zentrum Dresden-Rossendorf, who supported this work.