

# BE Department Annual Report 2010

O. Brüning, E. Ciapala, P. Collier, R. Garoby, E. Hatziangeli, R. Jones,  
M. Lamont, A. Mackney, J.-P. Matheys

## Abstract

The Beams Department hosts the Groups responsible for the beam generation, acceleration, diagnostics, controls and performance optimization for the whole CERN accelerator complex. This Report describes the 2010 highlights for the BE Department.



# LHC:

## BE-ABP [Group](#)

### LHC commissioning (protons and heavy ions)

Participation in the LHC beam commissioning represented a large fraction of the ABP activities in 2010. Aperture measurements and data analysis were performed in collaboration with the OP team. The optics measurement and correction activity achieved excellent results both in terms of quality of the measurements, but also for the various correction techniques developed and successfully applied. The final result is a beta-beating under control and within tolerance throughout the whole LHC cycle. The optics correction using the standalone insertion magnets was performed in closed contact with the FiDeL team with a very fruitful collaboration allowing key improvements of the magnetic model of, e.g., the warm quadrupoles. The residual beta-beating, but also the much smaller than specified spurious dispersion measured in the machine, is then a clear signature of the magnet sorting strategy which was implemented during installation. This included the random  $a_2$  and  $b_2$  multiple imperfections of the main dipoles and quadrupoles for which no specific corrector knob would have been available in the LHC. The setting generation performed by OP using the optics computed by ABP and stored in the dfs data repository has become a routine operation. The domain of luminosity calibration and optimisation was also an area of intense efforts with key contributions in terms of tools, measurements, and data analysis.

A model was further developed to describe the trajectory and charge evolution of a macro particle falling into the beam as well as the resulting beam loss. The peak loss duration, the dependence of loss rate on beam intensity, and the time distance between possible multiple crossings all seem consistent with the observed UFO events.

Electron-cloud simulation activities were re-launched at the end of 2010. Surface properties of LHC vacuum chambers have been inferred from benchmarking simulations with observations. The simulations helped to define scrubbing and running scenarios for 2011, as well as to guide the longer-term operation modes and upgrade path. Complementary studies have addressed the heat load, beam stability and emittance growth from electron cloud.

The preparation and rapid commissioning of the spectacularly successful first heavy-ion run was also an important activity. Interpretation of the measurements, e.g., the beam losses from nuclear effects in the collisions and collimators, debunching and emittance blow-up, is also a field of intense activity. Mitigation measures for the well-known limitation due to the relative positioning of the TCTVB collimators and Zero-Degree Calorimeter around the ALICE experiment were proposed and analysed and will be implemented in a forthcoming shutdown.

### LHC Injector proton and ion operation

The LHC Injector Synchrotrons Section of the ABP group contributes to the operation of the accelerators of the PS-SPS Complex and LHC with a team of Machine Coordinators. During the whole LHC proton run particular effort has been devoted to transverse emittance preservation all through the chain, up to LHC high energy. This showed the feasibility of accelerating throughout the injector chain and of colliding in LHC beams with brightness at least 50% larger than nominal, culminating in a luminosity of  $2 \times 10^{32} \text{ cm}^{-2} \text{ s}^{-1}$ . Not only the quality but also the variety

of beams delivered by the injectors to the LHC in 2010 for commissioning and physics is impressive.

2010 has also marked the successful completion of the “Ions for LHC” Project with the ion physics run greatly exceeding the expectations thanks to the quality of the beam delivered by the injectors where bunch intensities above nominal by more than 30% have been obtained transverse emittances smaller than nominal and with remarkable stability.

## BE-BI [Group](#)

### LHC Beam Instrumentation / LHC Beam Position Measurements:

The LHC Beam Position Monitoring (BPM) system is composed of 1054 monitors. By design the system can function in neither a totally asynchronous acquisition mode, not requiring any external triggering nor synchronization signals. It was available since the first injection with a very low downtime of less than a few hours during LHC operation. On average 97% of the individual devices were active and working correctly, with the missing 3% mainly being the interaction region BPMs where cross talk between the two beams was an issue.

Commissioning of the LHC orbit feedback system started soon after the first beams were injected and this system has been successfully used ever since, with a very positive impact on the operational efficiency of the LHC.

The main issue encountered this year was the strong correlation observed between position drifts and thermal changes in the electronic racks. Over extended periods this effect limited the accuracy of the measurements to 300-400 $\mu\text{m}$ . During the summer a procedure was put in place to calibrate and automatically compensate for these temperature drifts. The final accuracy attained was  $\sim 100\mu\text{m}$ , still limited by the residual temperature dependence. For the longer term, thermally stabilized racks are envisaged to be installed.

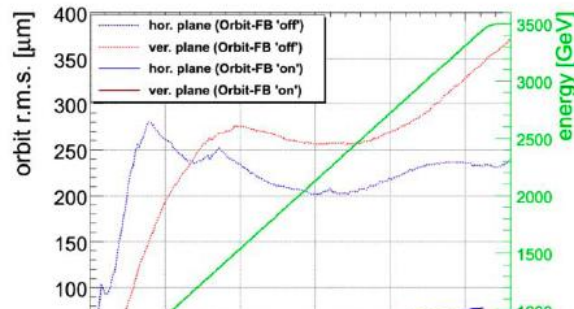

Comparison of orbit stability during the ramp with and without feedback

### LHC Beam Loss Measurements:

The LHC beam loss monitoring system is used both for the protection of equipment and for the tuning of the accelerator. After one full year of operation it can be stated that the system never failed to react for any of the hundreds of critical beam loss events. In addition, the number of false beam aborts was well below expectation. The injection, dump and collimation systems make continual use of the published data for system analysis and optimization. One example of its importance is in the reliance of the collimation upgrade planning on the actual measured losses for various scenarios. The calibration accuracy of the system was of great interest in terms of maximizing the availability of the LHC while minimizing magnet quenches. These thresholds had only ever been simulated before and therefore several intentional magnets quenches were provoked to verify the accuracy of the predictions. The thresholds were only found to be a factor 2 too high, which for this kind of system, can be regarded as excellent agreement between reality and simulation. This analysis has a strong impact on the prediction of LHC operation at 7 TeV

where the beam abort limits were found to be about a factor 5 lower than foreseen for nominal operation.

The beam loss system was also used to study spurious losses, which were found to occur at all locations around the ring. These losses, thought to be caused by “Unidentified Falling Objects” or UFOs, were found to have a duration of between 0.3 to 3 ms and in some cases were significant enough to cause a beam abort. The event rate of these UFOs was seen to be directly proportional to the number of stored bunches.

Some initial successful tests were also performed with diamond loss detectors, capable of distinguishing losses on nanosecond timescales.

Several more of these detectors will now be installed around the injection and collimation regions.

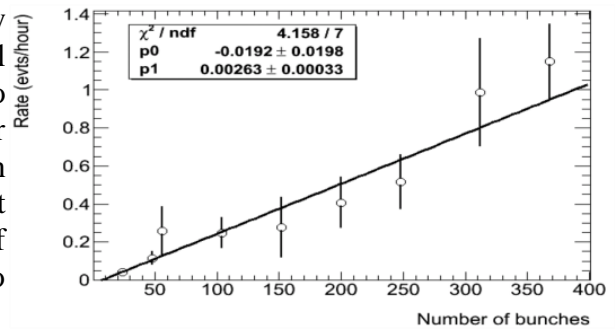

**Event rate dependence of UFOs on the number of bunches stored.**

### LHC Beam Current Measurements

During the year the intensity range covered by the BCTs in LHC spanned from a few  $10^9$  to several  $10^{13}$  charges. The DC Current Transformers performed well and within specifications with low intensity beams (and in particular during the ion run). Unfortunately, things degraded significantly with moving to 75 ns filling schemes where the DCCTs started to over or under estimate the number of protons stored in the machine depending on the filling pattern used. Some mitigation measures were attempted during the year but were ultimately unsuccessful. The real cause of the problems, saturation effects in one of the feedback loops, was only identified towards the end of the year when it became possible to simulate the same effects in the laboratory. A solution has now been found to remedy the situation and will be implemented during the end of year technical stop.

While these DCCTs are used to evaluate the total beam current circulating in the machine, the fast BCTs allow measurement of individual bunch intensity. This measurement is an important parameter for the luminosity calibration runs performed by the experiments. During the year a lot of effort was invested into assessing and understanding the performance of these monitors. Several issues were discovered, including a dependence on bunch length and the position of the beam within the transformer vacuum chamber, the latter being well outside the specifications given by the manufacturer of these toroids. BCT experts are currently investigating these effects but it is not clear if it will possible to find suitable cures for the existing monitors.

Despite these issues and thanks to our close collaboration the PH department and the well defined context of the dedicated luminosity calibration scans, it was nevertheless possible to achieve a performance level which is already close to the targets defined in the original LHC functional specifications for beam intensity monitoring. These results are described in details in the Lumi Days proceedings and in two notes dedicated to the April-May and October Van-de-Meer scans.

Another issue related to the absolute measurement of individual bunch intensity is the amount of beam which is not residing in the expected main bunch locations. In order to quantify these

satellite and ghost bunch populations a Longitudinal Density Monitor (LDM) relying on synchrotron light from the synchrotron light telescope (BSRT), was tested this year on Beam 2. Its aim is to produce a high-dynamic-range longitudinal intensity profile. So far a dynamic range better than  $10^4$  has been demonstrated with integration times of 5-10 minutes. As shown in the figure, this is sufficient for the detection and characterization of satellite and ghost bunches, which becomes very important to achieve the accuracy requested by the experiments during their luminosity scans. A measurement with lower dynamic range measuring the length, shape and relative current of all full bunches around the ring is possible to be obtained within a few seconds.

During the winter technical stop Beam 1 will also be equipped with an LDM and efforts are ongoing to incorporate the LDMs into the standard LHC control system (FESA) and have the relevant data logged.

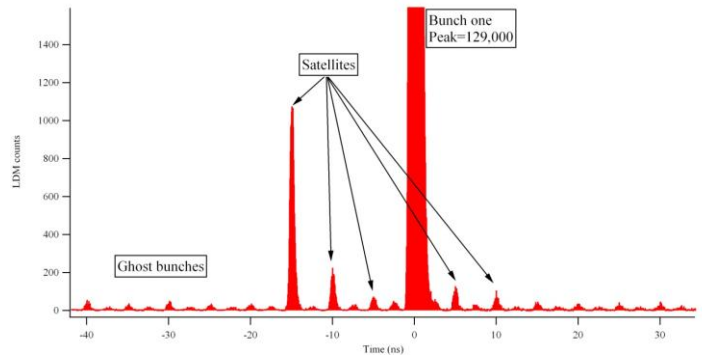

The amount of beam in the abort gap is monitored via the Abort Gap Monitor (BSRA), again using light from the synchrotron light telescope. This uses a sensitive, gated photomultiplier to look at the light produced from any particles in the 3 $\mu$ s preceding the 1<sup>st</sup> bunch: i.e. the abort gap required for the beam dump kicker. In 2010 these two Abort Gap Monitors, one per beam, were operational and were used not only to monitor the Abort Gap but also to study the efficiency of the transverse damper during machine development time dedicated to injection cleaning studies. They proved to have the required sensitivity to measure the Abort Gap population in the whole 450GeV-3.5TeV energy range with protons. During ion operation it was also confirmed that the light production for heavy ions is insufficient below 1TeV for effective use of the BSRA, and may be something that needs to be addressed in the future.

### LHC Luminosity Measurements

Although it was already possible in 2009 to observe signals from the various accelerator luminosity monitors (BRAN), they were only properly commissioned during the 2010 run. Three types of BRAN detectors are currently installed: fast ionization chambers from LBNL (BRAN-A), the CEA-LETI CdTe based (BRAN-B) and finally some plastic scintillators (BRAN-P). Both the BRAN-P and the BRAN-B are very sensitive and could already be used at very low luminosities, while the BRAN-A (commissioned by the Berkeley team) could only be used when the luminosity exceeded  $10^{30}$ .

All three systems were routinely used by operation to set up collisions for physics and proved reliable throughout the year. The figure shows typical BRAN readings versus time during a Van Der Meer scan, with the peak in collision rate clearly visible as the two beams are brought into overlap.

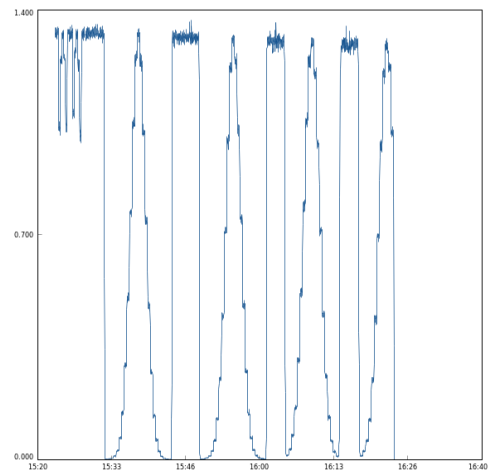

As expected, the BRAN-B and BRAN-P started suffering from pileup toward the end of the proton run when the luminosity was increased to above  $10^{31}$ .

For 2011 the BRAN-P will be removed as the scintillator material is not radiation hard and would not survive the expected 2011 luminosity. The BRAN-A will therefore become the default detectors for adjusting the machine for these higher luminosity levels after the commissioning of their pulse height mode.

### LHC Beam Profile Monitors

Two Beam Synchrotron Radiation Telescopes (BSRT) (one per beam) are installed around IR4 to image the synchrotron radiation emitted by protons and heavy ions. After their commissioning in 2009, the detectors were extensively used and studied during the 2010 run. This allowed their present limits in terms of sensitivity, accuracy and resolution to be established. For the first time in the world a synchrotron light image was captured from heavy ions, something which was already possible at 450 GeV by averaging 17 bunches for 20 ms. The upgrade to an intensified video camera capable of gating 25 ns also permitted the acquisition of single bunch profiles even with a LHC proton pilot bunch ( $\sim 5 \times 10^9$  protons) at 450 GeV and a single lead ion bunch ( $\sim 1 \times 10^8$  ions) from about 2 TeV. As shown in the figure these BSRT measurements could be used to clearly demonstrate the difference in transverse emittance between the different bunch trains. 2011 will be dedicated to providing the BSRT data in a fully automated, operational manner and in further assessing the accuracy and resolution of the measurements.

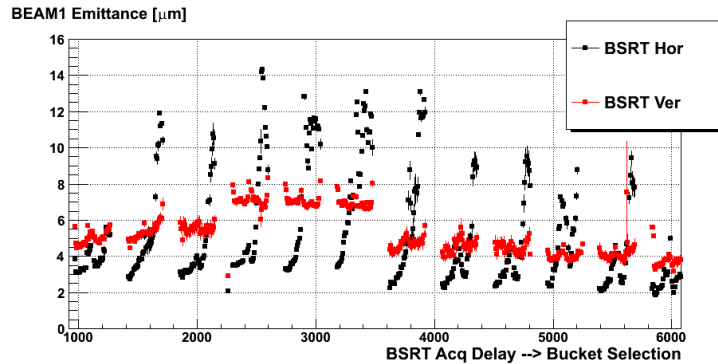

### LHC Tune and Chromaticity

The LHC tune, chromaticity and coupling measurements rely on the diode-based base-band-tune (BBQ) technique. Under most beam conditions the remarkable sensitivity of the BBQ system allowed a directly measurement of the tune using residual beam oscillations without the need for further external excitation.

With full magnet pre-cycling, the fill-to-fill tune reproducibility was typically observed to be  $\sim 2 \times 10^{-3}$ . However, during the early commissioning variations were significantly higher and the tune feedback system was therefore crucial to maintain the tune stable during the ramp. Even with feed forward control, it is still used routinely for all operational cycle.

The LHC transverse Schottky monitors were brought into operation during the summer and used with both proton and lead ion beams. In addition to the tune, the system is in principle also capable of providing the chromaticity, energy spread and emittance, but further study is required to verify and cross calibrate these.

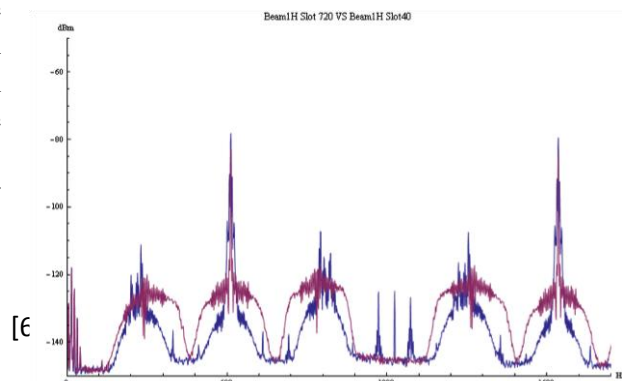



Strong coherent lines were visible for the proton Schottky spectra, making it difficult to accurately analyse the data. For lead ions, however, textbook spectra were obtained all the way from injection to collision. The figure shows a typical Schottky spectrum from protons (blue) and lead ions (red).

## BE-CO [Group](#)

### The LSA project

In 2010, the efforts of the LHC Software Architecture (LSA) team were focused on two areas - further improvements for the LHC settings management and deployment of the system for the PS machine as a part of the Injector Control Architecture (InCA) project.

The LHC settings have been enhanced by the introduction of Tune Feedback parameters, extensions to the Beam Loss Monitors and Collimator settings. To ensure coherent setup of the equipment, online checks of settings loaded to the hardware have been implemented for most of the equipment types. The functionality is used before each phase of the LHC cycle (from injection to physics) and on a regular basis for the other machines.

In addition, several concepts have been generalized and extended to fulfil the requirements of the PS complex, where the system is being successfully used since the end of June.

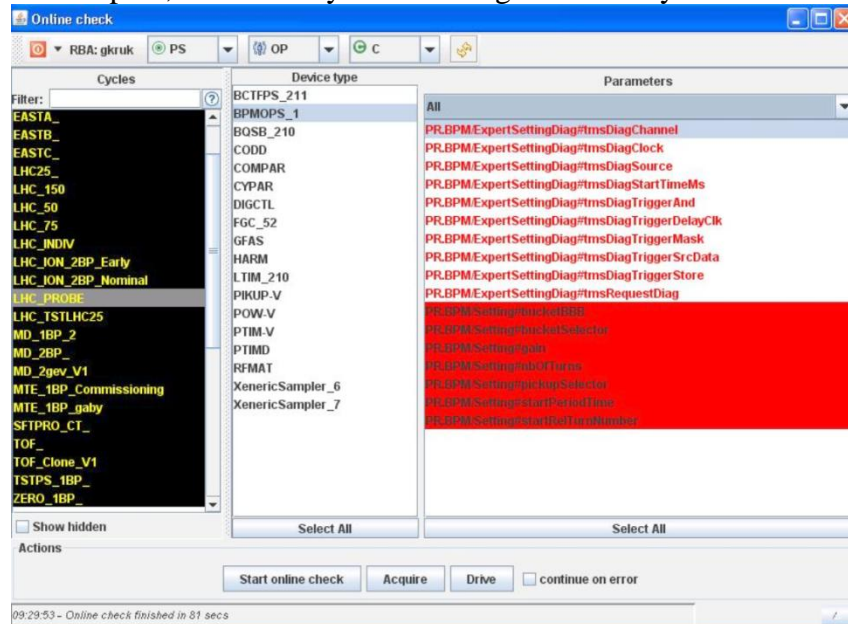

Online check GUI

### New LHC Sequencer Execution GUI

In 2010, members of the CO/AP section developed a new Execution GUI for the LHC Sequencer, which replaced the previous GUI that did not satisfy the needs of the operations team. The new GUI was developed in close collaboration with OP, with input from all EICs and from several operators. It builds on the experience gained during the first months of LHC operation, and focuses on user friendliness and safety.

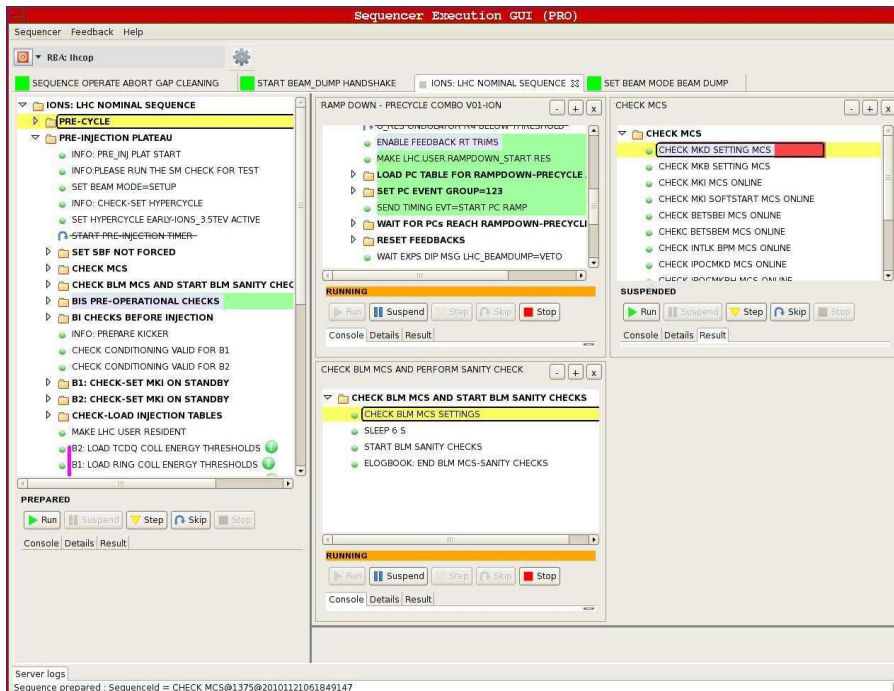

## The new Sequencer Execution GUI

### The Software Interlock System (SIS)

SPS and LHC SIS installations have entered their stabilization phase with over 5000 subscriptions and 2500 active channels each running in a very reliable manner throughout the year. A noteworthy change was an introduction of the LHC file browser allowing for quicker log viewing and faster operational interventions in case of problems. A direct connection to the Postmortem system was introduced which enables further analysis of SIS triggered dumps. The SIS concept has expanded to include ISOLDE where it surveys equipment and generates alarms in case of problems. Also the new Linac2 installation, intended to supersede the old watchdog software, was successfully tested and will enter production stage early 2011.

### The Post Mortem Analysis java project

During the year the Post Mortem Analysis (PMA) has significantly evolved into a mature reliable framework. The 4 analysis servers (processing Global Dumps and Powering Events information, performing external Post-Operational Check and Injection Quality Check) based on this framework became a part of decision chain for operations. Several new hardware systems were connected to PMA in order to provide their data for analysis. The summary of each analyzed event is stored into a database for easy searching and statistics. Apart from the analysis functionality, particular attention was paid to the data and result presentation. The framework allows plugging in so-called data viewers, which are developed by the domain experts. In addition, common data viewer was developed allowing displaying data from different information sources on one plot.



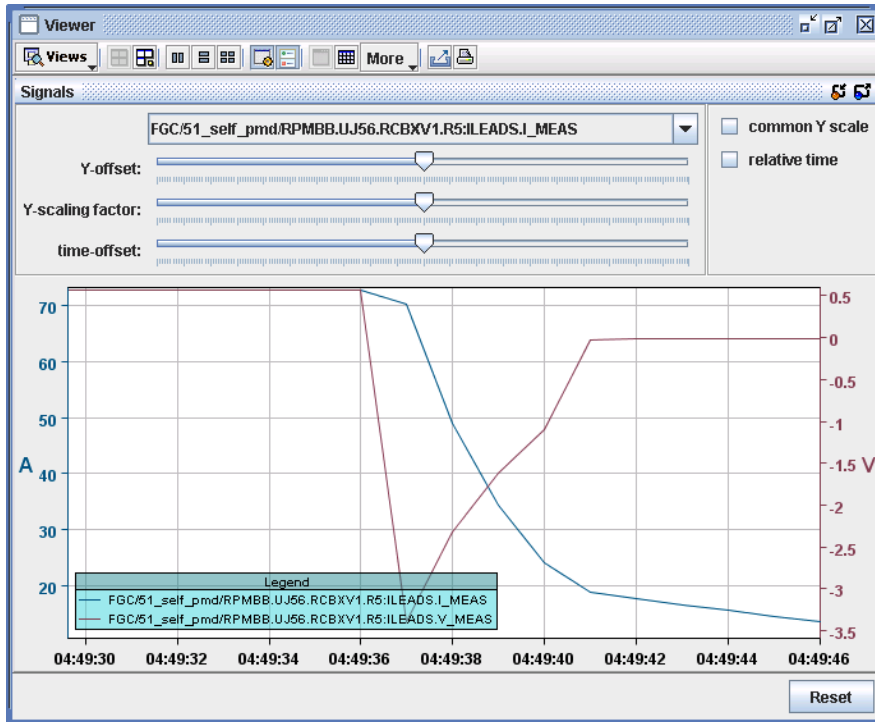

PM analysis data viewer

### The LHC BLM/BPM concentrators and framework

LHC BLM/BPM concentrators kept on serving data 24/7 to several OP applications throughout the year. The concentration framework was well stabilized and the middleware issues of the past were overcome. Some improvements helped efficiently communicate to a growing Post Mortem environment. New types of concentrators have also been identified by their main customers and, along with the refurbishments of existing infrastructure, will be provided for the 2011 startup.



Beam Loss Monitors GUI

## The State Machine framework and the Operational State Machine

The State Machine Framework provides a variety of functionalities to support building state machines. It was used for a production purpose for the first time during last year. Operational State Machine (OSM) was devised to support LHC operators in the process of driving the machine between major operational states, in a safe and sound way. OSM interacts with the LHC Sequencer to validate if state changes are possible by performing several well-defined checks through so-called checklist tasks.

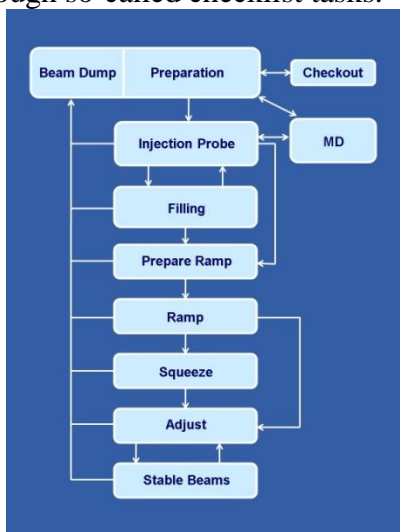

### Operational states

A dedicated GUI (an extension to the Sequencer GUI), has been created to support the users. Several additions are planned to increase the scope of Operational State Machine idea. The tools will be commissioned in the 2011 startup.

### The Controls Testbed

The CO testbed shall validate the core components of the control system before they are deployed in operations. In June 2010, a fellow was hired, who managed to prepare a first useful version. It covers components from Timing, FESA, CMW, proxies and JAPC, written both in Java and C/C++ and running on various computer architectures and operating systems. A series of function tests are executed every hour. In the course of the year, they found several non-conformities in the core libraries. Unfortunately, deploying new versions of controls system components proved to be tedious for the developers, which limited the usefulness of the testbed. The fellow therefore focused on automating the deployment, which was easy for Java components, thanks to common build, the automatic build system. For C/C++ no such system exists, and it was decided to put one in place as a collaboration between BE/CO, EN/ICE and PH/ADO. The system shall provide reproducible builds, versioning and dependency management. At the end of 2010, a proof-of concept prototype was ready. It is based on Maven technology and capable of building versioned binaries of FESA, CMW, and Timing (PPC4 only). Thanks to this tool, deployments to the testbed will be fully automated in 2011 and validation in the testbed shall become a mandatory step in the CO development process.

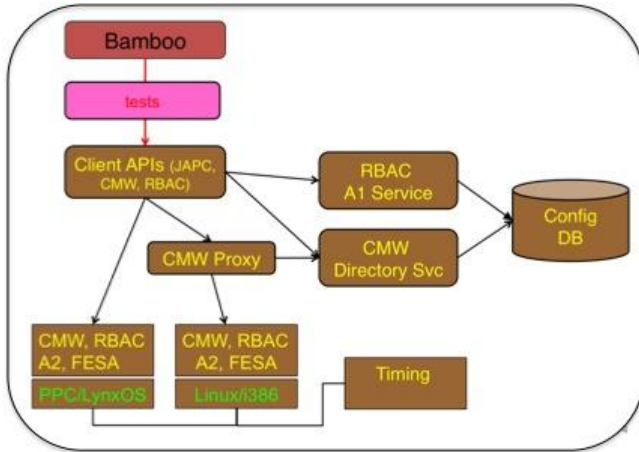

The CO testbed and the core components under test

### The Logging Service

The Logging Service captures time-series data from accelerator equipment, in order to provide the means to get a better understanding of the machine behavior and performance. With the sustained LHC beam operation throughout the year, the share of beam observation data gained enormously in importance, data rates and data volumes. Unfiltered data rates, publicly accessible in the short-term “Measurement” database, exceeded 250 GB/day. The accumulated filtered data in the long-term “Logging” database has reached an impressive 60 TB with an average of 110 GB/day over the period of beam operation. The configuration of the 200’000+ channels, from their FESA device source to their signal name, is now fully described in the database, simplifying laborious configuration management procedures.

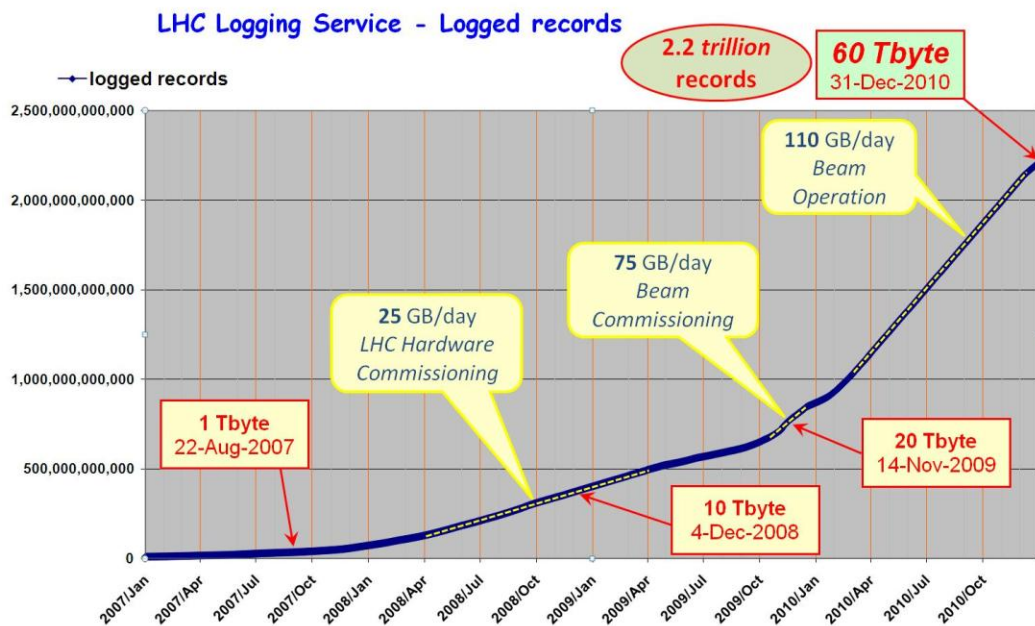

The LHC experiments expressed their strong interest in machine data such as beam and bunch intensities, positions, sizes and luminosities. To fulfill their requirements, an extensive programmatic interface was developed and deployed, enabling software applications to retrieve and process logged data. As a consequence, by the end of 2010, more than 80 custom

applications make use of this interface for a wide variety of analysis purposes such as statistics, post-mortem, data mining with respect to the hump, etc. The interface also allows correcting and computing time-series data, for example to eliminate systematic errors in bunch intensities or to calculate transverse beam emittances. In addition, the augmented use of the Logging Service for the injector chain is noticeable, both for data storage as for data analysis.

TIMBER, the interactive graphical tool of the Logging Service is used extensively in the CCC and from office desktops. Its functionality has considerably evolved, permitting flexible and configurable selection criteria (e.g. based on LHC fill number and beam modes). With the drastically increased usage of the Logging Service, the monitoring infrastructure has been enhanced as well, which helped to ensure the smooth operation and robustness of this service throughout the year.

## **BE-OP [Group](#)**

### **LHC beam operation**

The LHC saw its first beam end February, after 2 month of Hardware Commissioning devoted to the final protection validation of the new QPS system (nQPS). Closed orbits and captured beams were established rapidly using the 2009 settings for the orbit correctors. Commissioning of the machine to 3.5 TeV with low intensity took place in March and led to first collisions with pilot bunches at 3.5 TeV on March 30th 2010. In April and May 2010 the number of bunches was increased up to 13 per beam, with bunch populations of  $2-3 \times 10^{10}$  protons.

In June the machine was setup for operation with bunches of nominal intensity. First ramp attempts showed that the beam became unstable due to head-tail modes. The beams could be stabilized with octupoles, larger longitudinal emittance and transverse damper. In July the first collisions were provided to the experiments with nominal bunch intensities and for a  $\sigma^*$  of 3.5 m. In the course of July the number of bunches per beam was increased to 24, leading into a machine protection stability run with 1 MJ of stored energy in August. At the end of August the number of bunches was increased to 50 per beam, and the luminosity exceeded  $10^{31} \text{ cm}^{-2}\text{s}^{-1}$ .

To push the luminosity by a large factor from that point, it was decided to switch to operation with 150 ns bunch spacing since this mode had the potential to increase the number of bunches above 400. Three weeks were devoted to perform a cleaning of the machine settings, introduce crossing angles in all phase including stable beams, set up the collimators for all conditions and perform all the machine protection validation tests. First stable beams with 150 ns spacing were provided on September 22nd with 48 bunches. The intensity was then gradually increased in steps of approximately 50 bunches. At each step at least 3 fills with 20 hours of stable beams had to be provided without machine protection issues to allow for the next intensity step. By the end of October collisions with 368 bunches were provided to the experiments and the luminosity reach  $2 \times 10^{32} \text{ cm}^{-2}\text{s}^{-1}$ : the luminosity target for 2010 had been achieved. The integrated luminosity of ATLAS and CMS was  $48 \text{ pb}^{-1}$ . The stored energy of the LHC beams at 3.5 TeV reached 25 MJ, an order of magnitude larger than at Tevatron and SPS.

During the bunch train period the first electron cloud driven vacuum pressure increase was observed near cold-warm transitions close to the four LHC experiments. It was also demonstrated that the electron cloud effects in those regions could be cured by small solenoid windings installed around the warm vacuum chambers. Tests with 50 and 75 ns beams suffered from even strong electron cloud effects, but the beneficial effect of scrubbing at injection was

demonstrated. So-called UFOs (Unidentified Flying Objects) perturbed LHC operation as the intensity was increased. The signature is a very fast beam loss on the time scale of 1 ms leading occasionally to beam dumps (in 18 cases). The UFO appeared essentially anywhere along the circumference. It is believed that UFOs are dust particles, plastic foils or other small objects falling into the beam. The trigger mechanisms and the exact nature of the UFOs are not yet understood.

### LHC run 2010

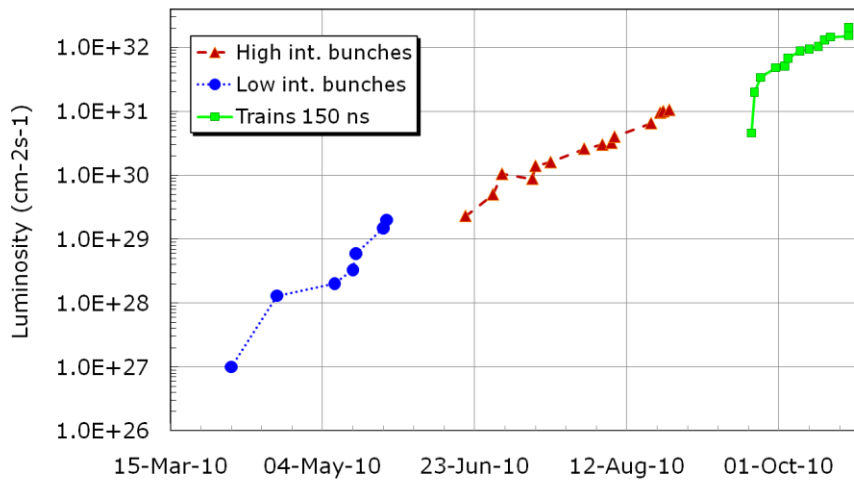

Evolution of the peak luminosity for proton operation.

In November operation switched from protons to Pb<sup>82+</sup> ions in a record time: after around 48 hours the first ion beams collided in the experiments. This led the way to a very successful and smooth lead ion run based on the ‘early ion scheme’. The peak luminosity reached  $3 \times 10^{25} \text{ cm}^{-2} \text{ s}^{-1}$  with up to 139 bunches per beam. The integrated luminosity was  $8 \text{ fb}^{-1}$ . The last ion beam was dumped on December 6<sup>th</sup> at 18:00.

### LHC Pb ion run 2010

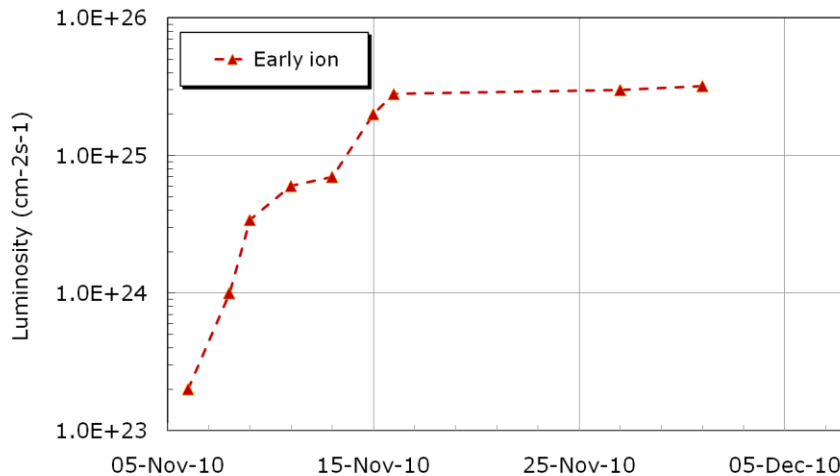

Evolution of the luminosity for ion operation.

## Technical Infrastructure

2010 was a year of uneven work load for the technical infrastructure operation with calm periods during LHC operation and very busy periods during the technical stops.

The number of telephone calls handled by the TI operators over the year clearly shows steady load between 100 and 200 calls per day during week-days when LHC is running and peak activity during technical stops with 300 to 400 calls per day and the end of year shutdown with 500 to 600 calls per day treated. A second operator is affected to the TI shift during technical stops as far as resources are permitting to help cope with the load.

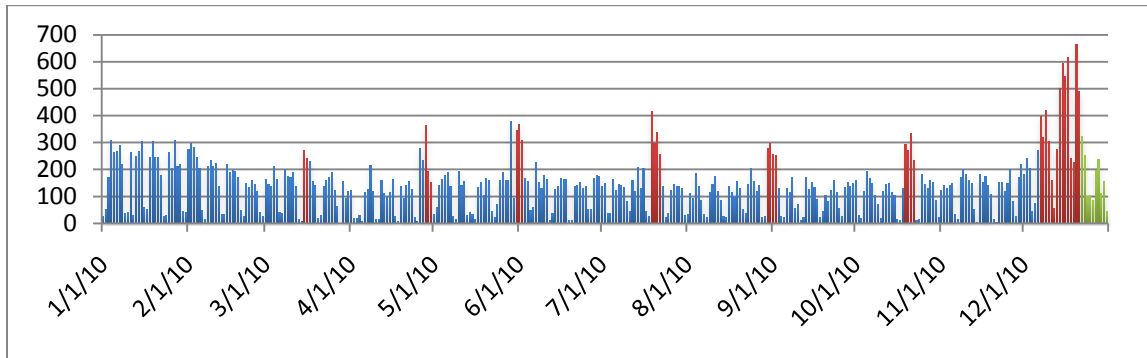

Number of phone calls treated by TI by day in 2010

2010 was also a record year for major event reports, with a 100% increase in the number of reports compared to the previous year (94 events reported in 2010 against 46 in 2009). Although the data is still being analyzed, there are some indications of why the number of events is rising; for instance, electrical perturbations went from two in 2009 to 14 in 2010 with indications that some are false events, where trips of the LHC machine will trigger events on the equipment detecting external electrical perturbations.

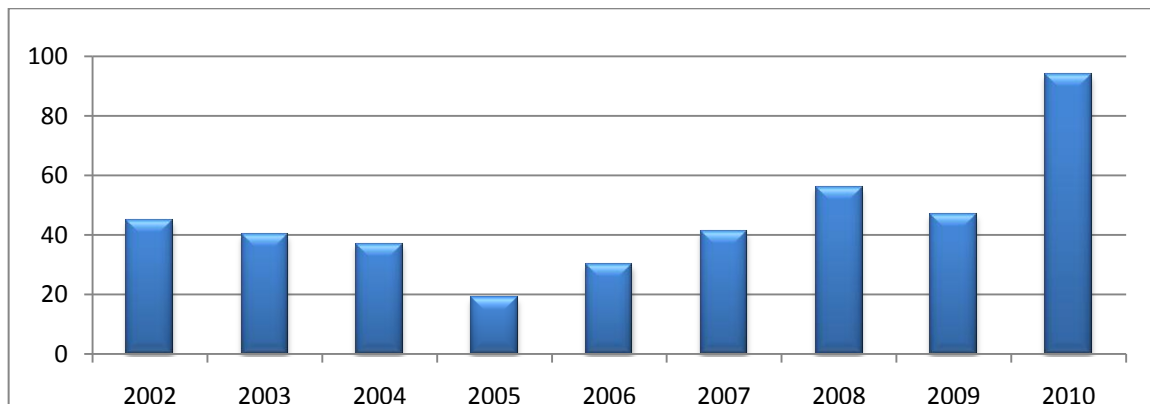

Number of Major Event reports edited by year



## **BE-RF Group**

### **LHC ACS Main RF Accelerating Systems**

#### **LHC high power and SC cavities:**

The year was marked by very successful operation of the LHC, and all the major systems, including the RF systems. The experience gained with the ACS (accelerating cavity systems) together with a substantial effort to improve reliability resulted in sustained trouble-free operation of RF equipment.

The RF cavities performed well, with only one ongoing issue. Since the LHC start-up, in November 2009, a strong field limitation of 2.2 MV had been observed on cavity 3 beam 2 (3B2), with sharp helium pressure spikes and relatively high radiation levels. The cavity is very stable below 1.2 MV, but has a rather unpredictable behavior between 1.2 and 2.2 MV; long stable periods are interrupted by sudden helium pressure spikes and temperatures increase of one of the four HOM antennas. Multipactor in the cavity equator region could be the culprit. Time would have been needed to further investigate and to try to re-condition this cavity, but this was not easily available with the tight LHC and cryogenics system schedules.

In 2010 SC cavity activity also took place in the SM18 area: the test cavity which had been polluted in an incident in 2008 was dismantled, then rinsed and reassembled in 2009, was successfully retested at high power and can be considered as fully recovered. A consolidation program for the fabrication of new spare LHC cavities to reduce replacement time in case of serious problems in LHC was also prepared and launched.

The key problem outstanding in 2010 for the RF power system was the klystron collector power limitation: all klystrons were limited to 7A and 50kV (instead of the nominal 8.4A, 58kV). The new design of the water collector jacket could be successfully validated in November, and four collectors were replaced during the winter shutdown.

In 2010, two klystrons had to be replaced in LHC due to different problems. Both could finally be repaired in the B112 test place and can now be considered as spares. Improvements of the high voltage system were also launched:

- The klystron current, and therefore the RF power, is controlled with a modulating anode. This HV control system is embedded in an oil tank which comprises the klystron heater transformer, measurements circuitry, and the modulation anode divider. The tetrodes which are used in the voltage divider scheme have a limited lifetime, and are no longer produced. A mid-term replacement solution was therefore deemed necessary. Development of a modulator based on a solid state solution was pursued and validation tests should take place in 2011.
- The klystron fast protection system is based on a five-gap thyatron crowbar. In case of an arc occurring inside a klystron, due to the high d.c. operating voltage, the high voltage must be removed from the klystron within less than one microseconds in order to avoid damage. The diversion of the HV energy is achieved by triggering the thyatron which then becomes conducting and acts as a short circuit to the HV power supply. Double ended thyatrons require very fine adjustment and are very sensitive to noise. Although they are very reliable from the safety point of view, they suffer, from time to time, from auto-firing, which result in beam dumps. Development of a solid state replacement was initiated.

### Progress with beam seen from RF

By the end of 2009 LHC had come back into operation with the successful capture of both beams and collisions at 450 GeV. On March 26th 2010 a first single bunch pilot was ramped to 3.5 TeV and RF test done. The bunch was captured with 8 MV, with a synchrotron frequency of 65.3 Hz. The voltage was increased to 12 MV before the ramp with a synchrotron frequency of 80 Hz, and then kept constant. Bunch lengthening was as expected from adiabatic evolution in the ramp and nothing dramatic was observed when crossing the much feared 50 Hz synchrotron frequency. Lifetimes were found to be good, and the bunch lengthening was around 30 ps/hour at injection energy and 6 ps/hour at 3.5 TeV, with these RF voltages. Bunch intensity was increased in the following months to reach the nominal  $1.1 \cdot 10^{11}$  p/bunch intensity. During initial ramps with bunch lengths of the order of 1.2 ns and low longitudinal emittance ( $< 0.4$  eVs) the bunch was violently unstable, the bunch length decreasing during ramping to below 500 ps with consequent loss of Landau damping. With longitudinal emittance blow-up not yet available yet in the LHC blow-up was done in the SPS to get an injected bunch length of 1.7 ns, (0.6-0.7 eVs), the maximum for injection in the LHC 400 MHz bucket. This was not ideal for capture losses; longitudinal emittance blow-up in LHC was therefore quickly made available, with first tests on June 15th. The system injects phase noise dynamically centered on the synchrotron frequency while continuously monitoring the bunch length. The functionality is mainly software based, running in the CPU of the beam control crate. Initially tests were very successful and the system rapidly optimized. Now with a smaller SPS bunch length of 1.5 ns ( $\sim 0.5$  eVs) and appropriate RF parameters the blow up could be adjusted to keep the bunch length constant at this value all through the ramp. This figure was reduced to 1.2 ns in September to prepare for bunch trains, resulting in a 1.6 eVs emittance on flat top. The LHC RF was operated with these longitudinal parameters (voltage and bunch length) for the rest of the year.

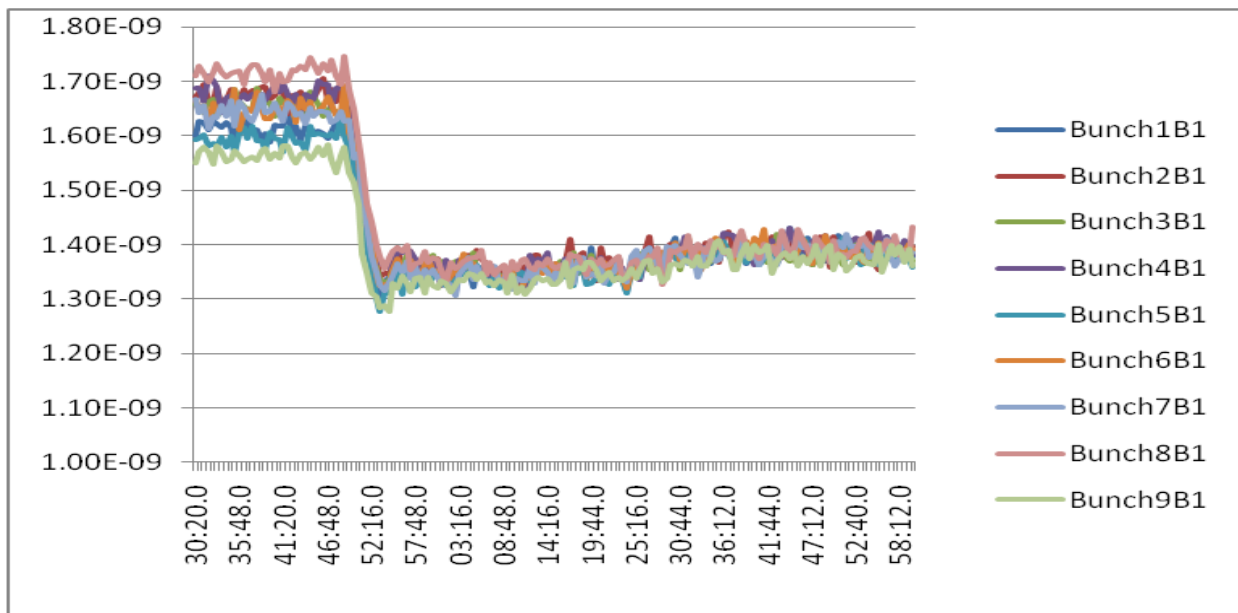

**Example of longitudinal blow-up in LHC: Bunch length (s) vs time (min).  
The initial bunch length decreases at start of ramp then is held constant by the feedback system.**

In the early part of 2010, with low beam intensities, the RF was run with not all cavities powered, a simple way of avoiding the klystron collector power limitation. From September, the

RF system was configured to operate with all klystrons on to avoid risk of instabilities from cavities operating without the active feedback needed to reduce their effective impedance. No major problems were encountered. Running continued smoothly, the number of bunches increasing to 368 nominal bunches at 150 ns spacing (12% of nominal ring intensity) by the end of proton running in October. However, with the increased number of injections, the injection dump would fire on occasion, triggered by radiation measured and found above threshold by the Beam Loss Monitors (BLMs). The problem was traced to a small amount of beam, un-captured at each injection, and slowly drifting in the machine.

RF noise had been a major concern in the RF design, particularly with the use of klystrons where HV ripples translate into phase modulation, with 50 Hz harmonics extending to 600 Hz. At 3.5 TeV the synchrotron radiation damping time is about two hundred hours. The target for longitudinal emittance blow-up growth time from RF noise was 13 hours minimum, corresponding to the synchrotron radiation damping time at 7 TeV. During acceleration the synchrotron frequency crosses the 50 Hz line and problems had been expected. The LLRF was therefore carefully designed to reduce noise sources, with a dedicated klystron feedback loop, and minimize impact on the beam.

All LLRF electronics worked perfectly in 2010: there are more than 50 VME crates installed with approximately 400 VME modules of 36 different types, all custom-designed. The only faults were caused by damaged cables and connectors: all SMC cables in the Cavity Controllers are to be replaced with higher-quality during the 2011 technical stops.

### LHC ADT Transverse Damper Systems

As part of the 2010 LHC start-up, the LHC transverse feedback system was successfully commissioned with beam. Damping times better than nominal were achieved and the system was run at high gain on the 450 GeV plateau. Following successful tests during the ramp and with colliding beams, operation of the LHC with the transverse feedback system rapidly became the standard procedure. This included operation with Pb-ions, but excluded the squeeze and periods of chromaticity measurements. The transverse feedback system contributed to the preservation of the smaller than nominal emittances by limiting emittance increase due to injection errors, the impact of external perturbations ("hump") and curing instabilities observed with chromaticity close to zero. See below a block diagram of the transverse damper system.

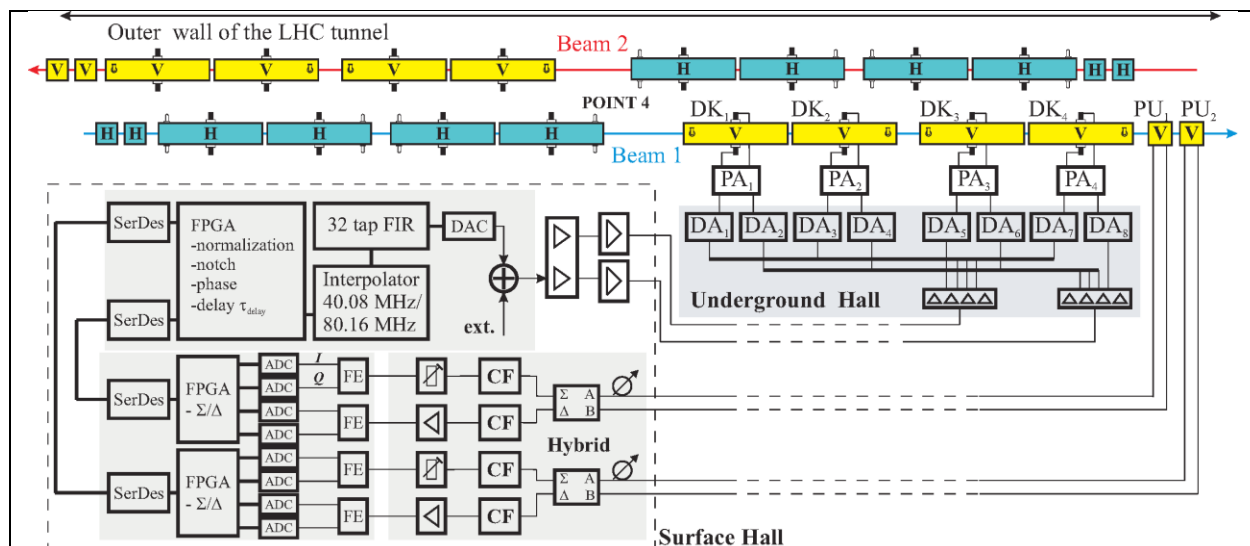

There are a total of 16 power amplifiers installed directly under the kicker tanks in point 4 of LHC. Per plane and beam a set of two coupler pick-ups is available to detect the transverse oscillations. Pick-ups and kickers are installed at locations with high beta function in order to have a high signal and a large impact of the correcting kicks on the beam oscillations.

The signal processing comprises an FIR filter to shape the response of the system with frequency in amplitude and phase as well as a scheme to combine the signals from the set of two pick-ups as vectorial sum either directly or after shifting them in phase using an FIR filter. In 2010 the system was run at the full available bandwidth (20 MHz low pass filter in the digital part) and with a phase compensating filter adjusting for the theoretical phase response of the power amplifiers with a 3 dB point of 1 MHz. The phase response of the 3/8" drive cables has been corrected by an analogue filter at the end of the cables in UX45 which was added in the shutdown 2009/2010.

The different phases of commissioning in 2010 with beam are listed in the table below:

22.04. 2011	first damping loop successfully closed with pilot bunches
17.06. 2011	full operation for nominal bunch intensity at 450 GeV
04.07. 2011	damper becomes operational with colliding beams
06.09.2011	signal-to-noise improvement by a factor two and operation with higher gain at 450 GeV
17.11.2011	commissioning with bunch trains of 50 ns and 75 ns, “scrubbing run”
21.11.2011	commissioning with ion beams at 450 GeV
23.11.2011	following tests with colliding ion beams, operationally used in collision with ions

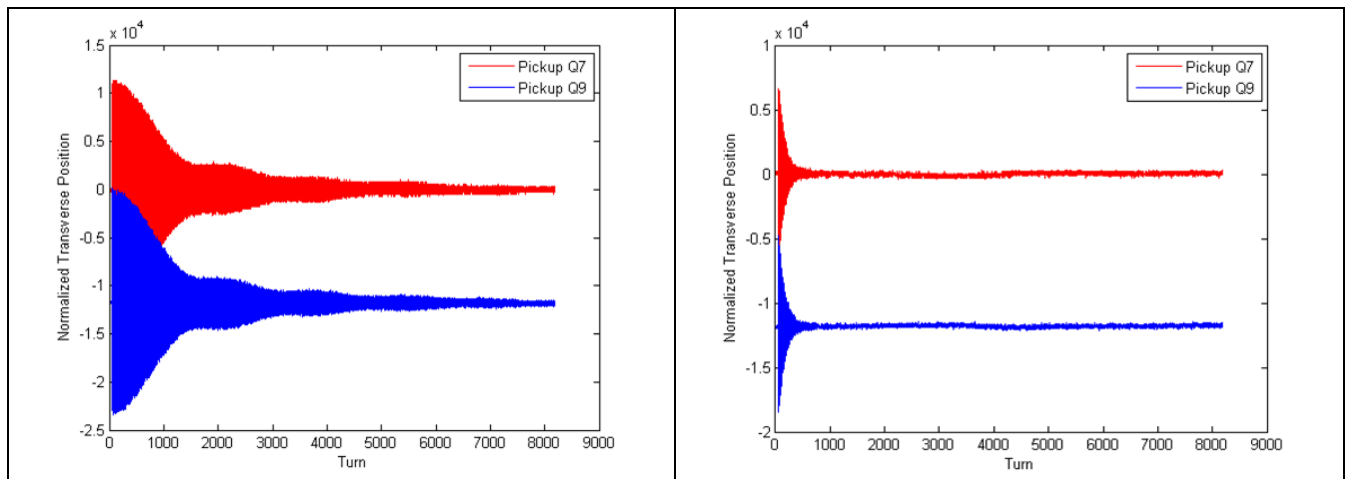

**The first damping of injection oscillations as achieved on 22.04.2010.**

Damping times were quantitatively analyzed and the nominal damping times of 40 turns achieved. Towards the second part of the run in 2010 the damper gain was increased to reduce the impact of external perturbations (“hump”) causing a transverse blow-up of the beam.

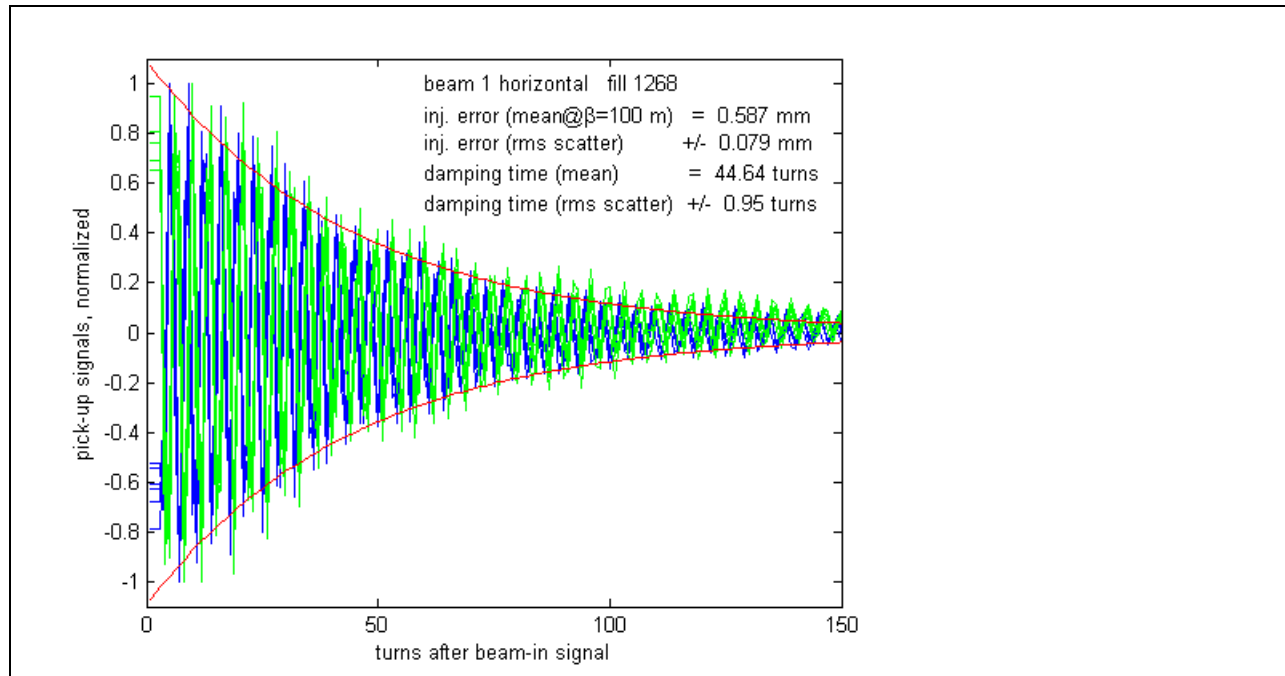

**Damping times for single bunches (horizontal, beam 1) in fill 1268. Injection errors and damping times are very reproducible**

The data from the pick-ups of the damper system can be used to evaluate not only the transverse injection errors and their damping but it also gives an abundant amount of information that can be used for beam diagnostics purposes. From summer 2010 onwards data from all eight pick-ups used by the damper system was stored in the logging data base for the first 8192 turns after each injection, and also visualized with the injection oscillation display.

## LHC Injector Upgrade and Neutrino Factory Studies

### BE-ABP Group

The so-called Transverse Mode Coupling Instability (TMCI) limits to  $1.6 \times 10^{11}$  protons the maximum single bunch population that can be injected in the SPS with no transverse emittance blow-up. The theoretical models describing this instability show that the TMCI threshold can be increased by modifying the optics of the machine and in particular by reducing the so-called transition energy of the machine. An elegant optics solution has been found and successfully tested during machine study, allowing the injection of more than  $3 \times 10^{11}$  protons in a single bunch with no sign of instability.

In 2010 the LIS section has also completed the design of a Negative Momentum Compaction optics for a new proton synchrotron replacing the PS (PS2). This includes the specifications for the linear and non-linear correction magnetic systems, the specification of the maximum magnetic errors for the main magnets of the machine and of the elements required for a Multi-Turn Extraction based on the capture of particles in Stable islands of the transverse phase space.

The contribution to the Interim Design Report for a Neutrino Factory with the evaluation of the performance of the muon front-end has been provided in the frame of the EUROnu Design Study in the Framework Programme 7 of the European Community.

## **LHC injector chain (Linac 2, Linac3, PSB, LEIR, PS, Experimental Areas and Associated Facilities)**

### **BE-ABP Group**

#### **LINAC2**

Linac2 ran for 6800 hours in 2010, and with an uptime of 99.2%, showing a very high level of reliability. However it still represents a significant risk for LHC operation due to the lack of maintainability of certain features of the cavity design. The impact of a failure to a quadrupole in the tank was reduced by the design and construction of an in situ drift-tube girder elevation system.

#### **LINAC3**

Linac3 produced ions for the first LHC ion run as well as 13 weeks of setting up of the LHC injector chain and 13 weeks of internal testing and setting up. Changing the plasma chamber material from aluminum alloy to stainless steel produced a dramatic increase in stability, at the expense of a considerable increase in RF microwave power requirement and an increase in x-ray emission. The improved stability contributed to a smoother operation period than would have previously been possible.

A Memorandum of Understanding was signed with iThembaLabs in South Africa. This first collaboration between CERN and an African Organization will help to pave the way to testing the production of different ions from the GTS-LHC ECR ions source, in order enlarge the range of ions available for acceleration in the LHC Ion Injectors.

In spite of the heavy load on the injectors due to the commissioning of the LHC the injectors have provided record integrated proton intensities for fixed target physics and in particular for CNGS where the expectations have been exceeded with a record of more than  $4 \times 10^{19}$  protons on target achieved.

#### **Fixed Target Proton and Ion Programme**

The last two weeks of the 2010 run were dedicated to a feasibility test for the production of light ion beams for NA61 in the H2 beam line using a lead primary beam from SPS at low energies (13 GeV/ and 80 GeV/u). One of the main issues for the operation at these low energies is the large beam size of the extracted beam which requires different optics in the extraction transfer line TT20 to the North Area. The design of a new optics has allowed to increase the transmission of the beam along the line by almost a factor 2 and to better match the size of the beam to that of the target.



## **BE-BI Group**

### **PSB Instrumentation**

The trajectory measurement in the Booster transfer line to the PS and ISOLDE was often perturbed by beam losses due to the high load impedance of the existing electrostatic pick-ups. It was therefore decided to replace these with inductive pick-ups which should be much less sensitive to such beam losses, while at the same time adding a further two such pick-ups to the ISOLDE line in order to improve the beam steering in this region. Despite manufacturing issues with the ceramic chambers used in these pick-ups half of the 12 pick-ups concerned have now been installed, with the remainder foreseen for installation during the 2011-12 technical stop.

### **PS Instrumentation**

The new PS orbit acquisition system (BPMOPS) is now fully operational and therefore in agreement with the end-users (OP/ABP), the old CODD will be dismantled during the 2010-2011 winter technical stop.

Several performance studies were made in 2010 on the renovated wire-scanners in the PS complex. Emittance and position measurements were compared to SEM-grid and Mean Radial Position measurements for different beam intensities and beam types in order to validate the system in collaboration with OP-PSB. Thanks to these measurements, hardware and calibration issues were detected and corrected, leading to a much improved performance by the end of 2010.

On request from OP, a study was launched to improve the accuracy of the beam current monitors in the PS complex. As a result, the calibration of the DCCT was reviewed and the error on their absolute accuracy determined to be around 1% rms for high intensity beams. The situation with the fast BCTs was less favorable since a large fraction of the error is believed to come from the monitors themselves. The low level acquisition chain and the calibration process for these systems was nevertheless reviewed, with the conclusion that a relative accuracy between consecutive shots on different fast BCT monitors should also be possible at the 1% rms level. These improvements are being implemented and should allow the performance necessary for optimizing operation with most beam-types to be reached in 2011.

## **BE-OP Group**

### **Booster operation highlights 2010**

The PS Booster had a very long and successful 2010 operation period. Right in the beginning of the year the Booster took part in a dedicated run of the injector complex to provide beams to the AMS experiment in the SPS North Area. Once this mission was completed, the Booster took up operation as LHC injector and delivered reliably the different flavors of LHC-type beams within specifications and on request. Starting with the early single-bunch beams for commissioning, soon the LHC requested multi-bunch beams with increasing intensity. Requests from the LHC were dealt with in a flexible way, e.g. the new 150ns beam, set up in single-batch transfer to the PS and routinely used by the LHC. In parallel, machine developments continued to push the LHC beams to ultimate intensity limits.

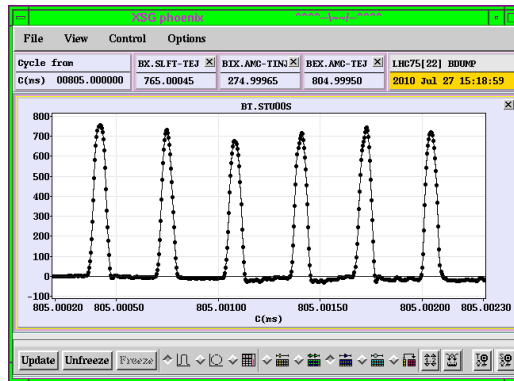

**LHC 150 ns beam in the PSB**

In parallel, and transparent for the LHC, the Booster delivered beams for the entire non-LHC physics program, with its main user of protons being the ISOLDE facility. For the CNGS beams a record intensity of  $3.7E13$  protons per cycle could be extracted within specifications. The average availability of the Booster beams for all users amounts to 92%.

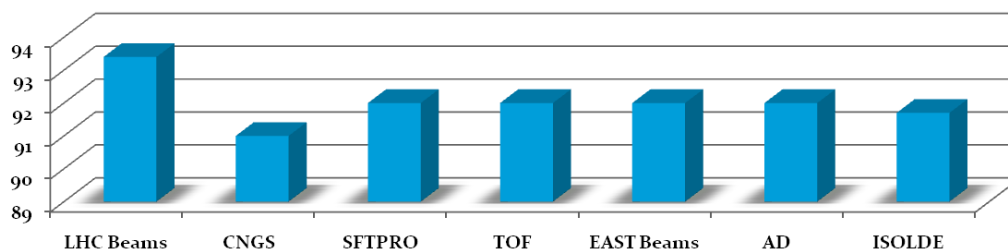

**PSB beam availability 2010**

Besides the physics program a wealth of machine developments was performed, notably in view of a potential upgrade of the beam energy to 2 GeV. A vast upgrade and consolidation program has been launched in order to enable the Booster to continue reliable operation and to satisfy future requests for ultimate LHC beam parameters.

### **BE-OP-PS**

The 2010 PS machine run started early and finished late. The main objective for the PS was providing the LHC with good quality beams of different types and varying parameters, whenever required. Besides this important task the PS had also to provide beam to the SPS for the rich fixed target program, CNGS, the various experiments and test beam lines in the East experimental area, the AD and the nTOF facility.

After a very short shutdown period the PS restarted in the second half of January, but was stopped immediately due to a problem with the motor-generator set that normally supplies the power to the main magnets. A repair of several weeks had to take place, but the AMS experiment in the SPS north area was requesting beam during the first week of February. In parallel to the repair of the motor-generator set, the PS was nevertheless started with beam using power from an 11 MVA transformer that is available as backup solution in case of problems with the motor-generator set. This limits enormously the PS capabilities, but the AMS cycle was well in reach.

Once the motor-generator set was repaired and the AMS experiment had finished data taking, the motor-generator set was re-commissioned and successfully used for the remainder of the year.

By mid-February the first LHC low intensity single bunch beams were produced in the PS and sent to the SPS, followed by the setting up of a complete new flavour of LHC beam. Besides the well known multi-bunch beams LHC25, LHC50 and LHC75 with bunch spacing's of respectively 25 ns, 50 ns and 75 ns an LHC150 with a bunch spacing of 150 ns was required. In a very short time this beam was setup, but the longitudinal emittance at extraction was compromised slightly by longitudinal quadrupolar bunch instabilities just after transition crossing in the PS for a bunch intensity of  $\sim 8 \times 10^{10}$  protons. The intensity was nevertheless pushed to the nominal  $1.1 \times 10^{11}$  and the LHC has successfully used 8 out of the 12 bunches possible per PS cycle throughout an important part of the run.

All the other LHC beam flavours were also setup for the many machine developments in the LHC injector chain and later, towards the end of the 2010 run, the LHC50 and LHC75 were taken by the LHC for e-cloud studies.

Another important result for the PS in 2010 was the nTOF integrated intensity that surpassed by 24% the total number of protons planned in 2010 for nTOF. Before the run  $9.6 \times 10^{18}$  protons were planned to be delivered to nTOF and on the 21st of November when the protons run was stopped  $1.194 \times 10^{19}$  protons were delivered on target

The main ingredient for this success was the increase of the dedicated nTOF beam intensity, which was pushed from  $7 \times 10^{12}$  ppp to  $8.5 \times 10^{12}$  ppp thanks to the dedication of the Ps operations team. This  $8.5 \times 10^{12}$  ppp has now become the new nominal intensity for the dedicated nTOF beam. Other contributors to this success were the continuous optimization of the number of nTOF cycles in the super cycle and the better than anticipated machine availability of  $\sim 93\%$  instead of  $85\%$  in 2009.

The PS also started delivering the fixed target and CNGS beams to the SPS using the Multi Turn Extraction (MTE) scheme, replacing the so-called continuous transfer (CT) scheme, which is well known for its losses at extraction. It distributes the beam losses, estimated at  $\sim 6\%$  of the total beam intensity, around the entire PS machine during the 5 turn extraction. After an initial period of running with the MTE a radiation survey around the machine showed the effectiveness for the MTE scheme. The radiation level around the entire machine went down considerably with respect to the previous years. However, the small number of losses, estimated at  $\sim 1\%$ , due to the extraction of de-bunched beam, were concentrated on the massive extraction septum (SMH16), which had become rather activated, making hands-on maintenance after a reasonable cool down period impossible. The MTE was stopped and the PS returned to the classical CT extraction in anticipation of a solution for the activation issue. Presently improvements are under study and the first tests with an alternative MTE scheme will be carried out in 2011.

The PS high level control system was also changed for an LHC Software Architecture (LSA) based solution. The Injector Controls Architecture (InCA) was deployed in the PS on Tuesday 29 June during normal beam operation. The new system is database driven and the initial aim was to obtain the same level of control as previously used. However, it came immediately with very useful functionalities like a history of all the changes made to all the machine parameters to which the machine could be reverted. Some initial bugs were solved and the system is now under further development to include the acquisition of machine parameters. With the introduction of InCA we have again a solid support team available for the PS high level control system.

The 2010 PS run was finished on a high note with a lead ion run for the LHC, but also for the SPS north area fragmented ion test. The delivered bunch intensity out of the PS was well above

the design values for the early beam version and the beam availability not taking into account the planned LINAC3 over re-fills was ~ 95% at the exit of the PS.

## **BE-RF Group**

In 2010, with the implementation of the automatic tuning for the 40 MHz cavities of the PS, the mechanical tuner, originally built for these cavities, started clearly showing its limits. Nowadays, during a single run, this tuner is asked to perform some 200000 displacements. For this reason a project for the renovation of the mechanical tuner system was launched and, within a crash program, a prototype has been fabricated on time to be installed during the end-of-the-year technical stop.



The consolidation of the 10 MHz system in the PS has significantly progressed with the installation at the beginning of the year and test, during the whole 2010 run, of the new low level control electronics, which was extensively tested with all operational beams. This was an important achievement that allowed the production and installation of the new electronics on all 11 cavities for the 2011 run.

### **LLRF in the PS:**

A brand new LHC beam variant was constructed in just two weeks, which was only possible thanks to all the previous advances with single-batch transfer from the Booster. This proton beam, with 150ns spacing, was originally mooted as a special low-intensity request by the ion

experiment, ALICE. In the end, however, it was the only multi-bunch used for all the experiments. This was achieved despite the unanticipated appearance of quadrupolar coupled-bunch instability during acceleration. Towards the end of the run, small numbers of bunches at 50ns spacing were taken by the LHC for scrubbing tests.

Lead ions were also delivered. The so-called early beam was used for physics at the LHC and the nominal beam, with its complicated batch expansion and bunch splitting gymnastics, was used for setting-up in the SPS.

In addition, ultimate and beyond ultimate LHC-type beams were produced for MDs. Thus, the 25ns beam was delivered to the SPS with  $1.7E11$  protons per bunch and a single-bunch beam was delivered at twice this intensity.

A sizeable reorganization of the low-level beam control for LHC-type proton beams in the PS saw a simplification and paring down of the hardware involved. Nevertheless, all four bunch spacing variants, 25, 50, 75 and 150ns, were made simultaneously available in the same supercycle.

## **LEIR**

The LEIR LLRF system confirmed its flexibility and excellent reliability during the 2010 run, where ion beams were routinely accelerated to be injected into LHC. Very few specialist interventions were required and the system ran virtually flawlessly. Effort was spent in improving the displaying capabilities under OASIS, in terms of trigger choice and display time base. Some time had also to be spent in re-commissioning the system integration within the controls infrastructure owing to upgrades in the controls interface (InCA). Last but not least, a cavity voltage calibration based upon the use of the Tomoscope application and a dedicated Mathematica™ program was successfully used in operation. Overall, the precision of this method is estimated to be of about 5%, i.e. much higher than the traditional hardware measurements done in many accelerators.

## **PSB LLRF renovation**

Remarkable progress was obtained in 2010 on the PSB LLRF renovation project, thanks to excellent teamwork. The main benefits of the new LLRF are its full remote and cycle-to-cycle controllability, built-in observation capability and flexibility. The overall aim is to improve the robustness, maintainability and reliability of PSB operation as well as to make it compatible with injection from the future Linac4. The new PSB LLRF system is the evolution of the one successfully deployed in LEIR. The building blocks are conceptually the same, but differences exist in the actual hardware and software implementation.

In 2010 the main decisions on the hardware building blocks were taken and prototypes were built. In particular, the VME Switched Serial (VXS) enhancement of the VME64x standard was chosen. This supports switched serial fabrics over a new, high-speed P0 connector, thus allowing a high number of flexible high-speed digital links between boards. The VITA57 standard FPGA Mezzanine Card (FMC) was selected as the daughtercard standard.

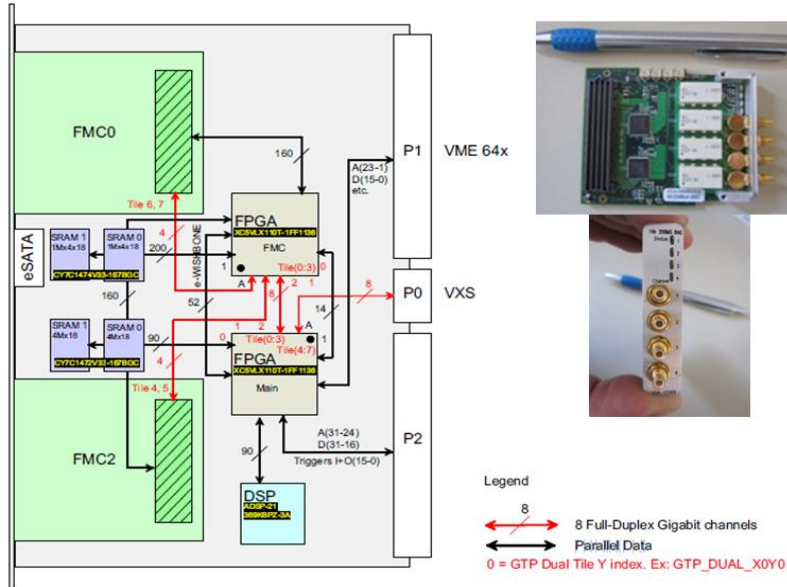

Conceptual design of the new motherboard (left) and prototype of one FMC daughtercard (right).

## SPS:

### BE-BI Group

The next generation of LHC collimator will be equipped with button pick-ups, which should provide the position of the jaw with respect to the beam with accuracy better than 5 $\mu$ m. A first prototype has been produced and tested in the SPS (see blue button on the collimator jaw picture). Two beam tests were scheduled in 2010 and demonstrated the good behaviour of the pick-up response even when the collimator was scraping the beam. Work is now concentrating on a novel electronic readout system for this system, which should allow for resolutions of much better than a micron to be achieved.

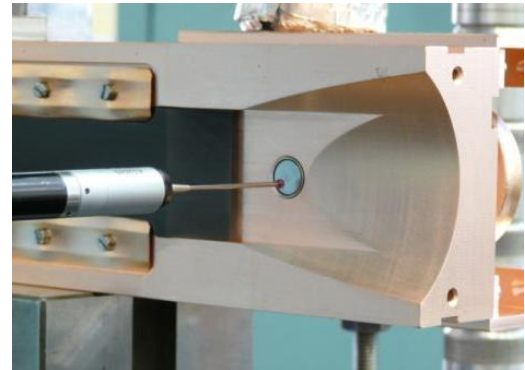

Installation of the instrumentation for HiRadMat is proceeding well, with the BPM system, fast BCT, BTV Screen and BLMs all foreseen to be ready for start-up of the facility in 2011. Their integration into the SPS control system should be relatively straightforward as they are all based on the existing SPS to LHC transfer line instrumentation.

The TI2 transfer-line is being equipped with several new pick-ups and a dual-plane position read-out system (as was already installed for TI8) during the winter technical stop.

The beam instrumentation electronics of the North Area Experimental Halls has undergone extensive renovation over the past few years. To conclude this effort, the controls infrastructure



was expected to be updated from LynxOS to the Linux based CPUs in 2011. Unfortunately, laboratory tests have shown that the more than 200 operational VME boards were not compatible with the new CPU modules. Work is still on-going in collaboration with BE-CO to find a solution for this issue.

## **BE-CO Group**

SPS Larger fixed displays have been greatly improved and runtime selection of currently displayed pages has been introduced together with the automatic BCT signal selection based on the timing content of the supercycle.

Many stability issues due to a large data set have been solved including data point filtering in LHC based applications and resolving delays in the injector chain applications. Work has been started to introduce SPS Page2 fixed display application at startup 2011.

## **BE-OP Group**

### **SPS operation in 2010**

2010 was a very long operational year for the SPS. It started the first of February with setting up the beam for the LHC together with a special AMS run in the North Area, and it ended on the 6<sup>th</sup> of December with ion beams for the LHC and NA61.

The CNGS beam was delivered at the end of April and the North Area physics started the 10<sup>th</sup> of May. Throughout the year the SPS was sending over  $4 \cdot 10^{13}$  protons per cycle on the CNGS target and to the North Area. Many experiments were served in the North Area, but the big consumer was COMPASS taking,  $2.5 \cdot 10^{13}$  protons per cycle on its target.

Several proton beam types were made operational for LHC injection: pilot bunches; individual bunches with high intensity and bunch trains with 150nsec, 75nsec and 50nsec bunch spacing. All these beams were available with nominal intensity or more and with emittances that were smaller than the design (2 to  $2.5 \mu\text{m}$  instead of  $3.5 \mu\text{m}$ ). These high brightness beams gave the possibility to probe some limits in the LHC (beam-beam tune shift, e-cloud etc.).

The last weeks of the run were dedicated to lead-ion operation, both for LHC and fixed target. As for the protons, the ion bunches which were delivered to the LHC, were "brighter" than foreseen, giving a successful heavy ion run in LHC. Ions were also sent to a Beryllium target in the North Area with different energies (80 GeV/nucleon and 13GeV/nucleon) in order to provide ion fragments of Boron and Carbon to NA61. The fragments could be identified and transported to the experiment.

The SPS also provided coasting beams of protons and, for the first time, heavy ions for the crystal extraction experiment UA9.

Different beam studies were undertaken in order to increase the performance of the SPS. Tests were done with an integer tune of 20, in order to push the TMC instability to  $3.2 \cdot 10^{13}$  protons per bunch. Studies were done in order understand the effect of C-coating on the electron cloud behaviour and others to avoid sparking on the electrostatic septum with the 25nsec bunch trains.

## BE-RF Group

In 2010, starting already in week 5 and lasting till week 49, the SPS delivering proton beams for fixed target physics, for CNGS and the LHC. From week 44 on lead ion beams for LHC and for fixed target physics were provided. In addition, proton and lead ion beams were used for the UA9 physics programme and for a variety of machine development sessions.

The main components of the SPS RF system, the 200 MHz and the 800 MHz RF power plants, the transverse damper system, the low level system and the controls software for these systems have been working well in 2010 and thus contributed to the excellent performance of the SPS; in particular that the number of protons on target (PoT) for CNGS exceeded the requested value by about 5%, with  $4.0 \times 10^9$  PoT delivered.

The main effort in 2010 for the operation of the SPS low level system was put into the setting-up, optimization and maintenance of the beam quality for the various flavours of beam requested by the LHC. The LHC expectations from the SPS beams concerned precise but variable longitudinal emittance, bunch length and sufficiently low intensities of satellite bunches. Proton beams with 1250 ns, 150 ns (new in 2010), 75 ns and 50 ns bunch spacing were delivered for LHC physics or scrubbing. The stringent LHC beam parameter requirements meant also that the RF beam observation hardware and software in the SPS and LHC had to be kept in optimal shape.

There were no particular issues with the fixed target proton or with the standard CNGS beams. However, the MTE beam, intended to replace the beam extracted by CT from the PS, required some study in the SPS and had to be abandoned because of excessively high beam losses in the CPS.

For the LHC and SPS lead ions programme the I-LHC beam low level was reconfigured, new hardware was installed and the Early Beam and the Nominal Beam were commissioned and optimized for operation. The best beam parameters for LHC were obtained with a single or a dual controlled longitudinal emittance blow-up.

## AD:

### BE-BI Group

#### AD Instrumentation

A new beam profile measurement has been developed for the Antiproton Decelerator (AD) based on a single Gas Electron Multiplier (GEM) with a 2D readout structure. The GEM is a  $10 \times 10$  cm polyimide foil, copperclad on both sides, and pierced with a high density of holes (see figure). A voltage applied between top and bottom creates an electric field in the holes that is orders of magnitude stronger than outside. When ionization electrons from interactions of beam particles with gas molecules drift toward the GEM, the charge is multiplied by a gain up to a few thousand per GEM inside these holes. This charge maintains the spatial information of the incoming electron and is extracted from the other side of the GEM by a readout circuit.

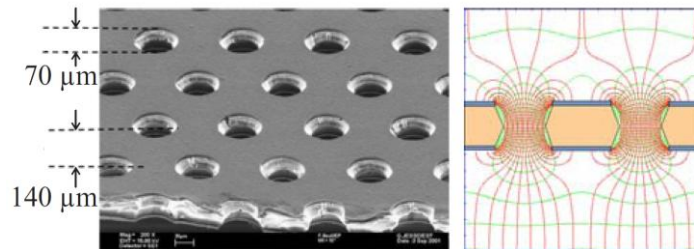

The detector is very light and measures horizontal and vertical profiles at the same time. This overcomes the problems previously encountered with the multi-wire proportional chambers (MWPC) currently used for the same purpose. In MWPCs the detectors for each plane are placed one behind the other, with the outcome that beam interactions with the first detector severely affect the results of the second. A prototype GEM was installed and successfully tested in late 2010, with preparation work ongoing to replace all 20 AD MWPCs with GEMs in 2011. The prototype system was also fully integrated into the standard control system allowing its acquisition from the AD control room.

## **BE-OP Group**

Starting on the 12th of April, 1 month earlier than in previous years, the AD was launched for its most exciting year so far. After the usual 4-week start-up and machine study period, the physics programme could start as planned on the 10th of May. By the end of the run more than 4500 physics hours had been totalled which is an all-time high. Over the year AD machine uptime was 91% and beam availability for physics was 87% with extracted beam intensities of up to  $4E7$  pbars per pulse with a repetition rate of around 100 seconds.

During the start-up period and also during the planned md-sessions, apart from the regular start-up and debugging, work was also carried out in the following areas:

- Commissioning of the renovated electron cooler power system: Faraday cage, HT transformer, converters, interlock system, safety installations, corrector dipole power converters and electronics/controls interface
- Ring optics studies: Beam blow-up during deceleration ramps, orbit response measurements, transverse tail formation at low energies, beam-based alignment checks of the compensating solenoids and optics studies in the ASACUSA transfer line.
- Blow-up rates due to multiple gas scattering at low beam energies.
- Tests of the new GEM detectors used for profile measurements in the ejection lines.

Work on the ELENA proposal continued where final optics design and a final layout of the installation in the AD building have been found along with an updated cost and manpower estimate. A decision on the future of ELENA is expected to be made shortly.

Progress was also made in the experimental area with the completion of the ejection line installation for the new AEGIS experiment which aims to study the gravitational behaviour of Hbars produced in flight. Installation of the experimental equipment will be pursued in 2011 and the first delivery of pbar beams from AD can be expected towards the end of the year.

2010 has to be considered as the best year ever for the AD physics program with the first-ever publication regarding the trapping of antihydrogen atoms in the ALPHA Neutral Penning trap. This first publication (in "Nature") refers to a few weeks in September where a total of 38 Hbars were formed and then kept in the trap for a fraction of a second. At the end of the year, up to 300 similar events had been recorded with measured lifetimes of up to several minutes.

ASACUSA also progressed very well and announced their ability to create and extract a focused beam of antihydrogen from their MUSASHI and CUSP traps. The antihydrogen success at AD led to a lot of media exposure, amongst others it was awarded the "Physics World 2010 Breakthrough of the year". This was a great achievement and perhaps the most important physics result of the year at CERN.

The hope is now that antimatter spectroscopy can start soon – perhaps even during 2011.

## **REX/ISOLDE:**

### **BE-ABP Group**

REX Isolde continued to produce a wide variety of radioactive ion beams above the coulomb barrier for physics. In 2010 it showed remarkable flexibility by changing very rapidly between different ion species and isotopes (during a 3-week period the ion type was changed 16 times). From the beginning of the year the Electron Beam Ion Source (EBIS) cathode showed poor electron emission, which could only be improved with the injection of gas. This is probably linked to improvements in the vacuum system of the EBIS, such that there is an insufficient oxygen partial pressure to burn carbon off the cathode surface. At the REX Penning Trap work continued in advance of a renovation of the Trap's powering and control system, foreseen for the 2010-11 shutdown.

### **BE-BI Group**

#### **REX Instrumentation**

The electronics of the old Isolde REX Instrumentation Boxes have recently given rise to a lot of maintenance problems. This system was therefore entirely renovated in 2010 and now uses a new VME controls board, a BI standard video-grabbing VME board and the new PicoAmpereMeter (PAM) for read-out of the Faraday-cup.

Isolde and REX between them have some 40 Faraday-cups. Their acquisition systems were all suffering to some degree or other from various problems related to long cabling, the multiplexing of signals etc, and leading to unreliable readout or poor resolution. All now have a new PAM readout system which was developed and deployed to overcome these issues.

A silicon detector has been developed and tested on the REX linac in the frame of the R&D program for the HIE-ISOLDE superconducting (SC) linac upgrade. In this very first test a passivated ion implanted silicon detector, suited for charged particle spectroscopy, was mounted inside a REX diagnostic box. The resulting energy measurements allowed for beam spectroscopy and ion identification with a quite good energy resolution ( $\sim 2\%$ ). The stable peak energy identification necessary for a quick cavity phase scanning procedure was also demonstrated for the 7GP3 cavity. Continued tests are now foreseen to further develop the monitor as far as beam intensity attenuation, energy resolution and electronic acquisition systems are concerned.

### **BE-OP Group**

#### **Exotic nuclei at ISOLDE**

ISOLDE can deliver more than 700 different beams of isotopes from 70 chemical elements and is currently one of the leading facilities for radioactive ion beams worldwide. In the 2010 beam period, about 470 radioactive ion beam shifts have been scheduled for more than 40 different experiments. More than half of these shifts are for post-accelerated beams with REX-ISOLDE and about 50% make use of the resonant ionization laser ion source (RILIS) to produce isotopically pure beams.

This year, the most intense  $^{11}\text{Be}$  beam has been post-accelerated at REX-ISOLDE. The Miniball detectors used by the IS430 experiment have registered a record  $10^6$  ions of  $^{11}\text{Be}$  per second behind the REX accelerator, produced in a tantalum-foil target coupled to the ISOLDE laser ion source. This corresponds to a primary beam of  $10^7$  ions per micro Coulomb (up to  $2 \times 10^7$  ions per second for the maximum PSB proton intensity at ISOLDE).

The first gold beams at ISOLDE have been delivered using the selective laser ionization RILIS. The neutron-rich beams of  $^{201}\text{Au}$ ,  $^{203}\text{Au}$ , and  $^{205}\text{Au}$  were used by the experiment IS447 in search for the postulated long-lived isomeric states.

A study on fission of mercury isotopes by the IS466 collaboration yield a surprising result: fission of  $^{180}\text{Hg}$  is asymmetric. (ISOLDE is unique in being able to create pure beams of such unstable heavy elements.) The results will be published in Phys. Rev. Lett. and have been spotted by Nature News and Science News.

The two-neutron transfer reaction of a post-accelerated beam of  $^{30}\text{Mg}$  at REX-ISOLDE/MINIBALL allowed identifying the first excited  $0^+$  state in  $^{32}\text{Mg}$  and thus proved the shape coexistence in this "island-of-inversion" nucleus. The results have appeared in Phys. Rev. Lett. and have been selected for a Viewpoint in Physics.

Beams of Rn and Ra isotopes have been post accelerated at REX-ISOLDE for the first time. REX-ISOLDE (which was originally designed for ions with  $A < 50$ ) has largely surpassed its design specifications and is now a unique facility for heavy post-accelerated radioactive ion beams. Furthermore REX-ISOLDE has now proven its reliability and can deliver beams with maintained performances for extended period of time (10 days) as was the case this year for  $^{44}\text{Ar}$  (IS499) or  $^{78}\text{Zn}$  (IS491).

In the coming years the construction of the HIE-ISOLDE accelerator extension, bringing the maximum energy to 10 MeV/u for ions with  $A/q < 4.5$ , will further extend the REX-ISOLDE capabilities and versatility.

## SURVEY FOR ACCELERATORS

During the technical stop of January 2010, upon a request of the operation team, the vertical survey of the main components of the TT41 (CNGS) line was done and showed some rather important misalignments. This area was realigned as well as all the components which were located at more than 0.3 mm away from a calculated smooth curve. The measurements seem to indicate that this line will have to be surveyed regularly.

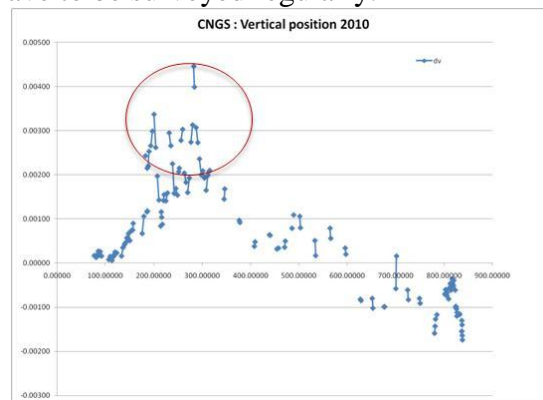

Vertical position of CNGS line

The survey team was much involved in the HiRadMat (TT66 beam line) project and achieved the determination of a geodetic network of points from the position of the neighbouring quadrupoles of the TI2. Then, the marking on the floor of the position of the entire component was done, as well as the preparation of the alignment of these components which is going to take place during the Technical Stop of January 2011. Moreover an extensive scan has been made in TCC6, TNC and TJ7 (at several levels) in order to know accurately the position of the civil engineering and all services and existing equipment.

In the North area of the SPS, in order to install a new K12 beam line in 2011, a survey of the existing components of K12 and part of P42 was done, before their dismantling. A link was also done with the elements of Na62, especially the Liquid Krypton. These measurements were used not only to determine a geodetic network but also to provide input for the calculation of the new beam line using Beatch.

Many scans were carried out during the renovation of the PS access system. The data is now available on the Web via the software TruView.

Survey Trains: Work was done this year on the finalisation of the software to drive automatically the collimator survey train and also to realise the final data treatment. The system is now fully operational. It will be tested during the next long shut-down. A few studies were also started with Hydrostatic Levelling Systems, especially the ultrasonic one from DESY, in order to verify that such a system could be used for a future LHC survey train to measure remotely the LHC arcs components.

Low beta quadrupoles : The Vertical and Horizontal realignment of the magnets in point 2 and 8, which was not done before the restarting of the LHC in November 2009, was carried out remotely in January 2010. Then, during the summer period, the roll angle of some components in point 5 and 8 was discovered to be far from the initial position (by some 0.4 mrad). It was decided to realign these magnets during the long Technical stop of 2011.

The permanent monitoring of the position of the low beta quadrupoles worked well. Some long term analysis of the data has still to be accomplished but in general, the low beta quadrupoles were rather stable during the run of 2010.

## SURVEY FOR EXPERIMENTS

Atlas: Beside the regular stability checks of the TAS, the EEs muon chamber circular support rails were adjusted on almost the full C side. Survey for experiments was also involved in the construction of an IBL mock-up made to prepare the beam pipe change. Concerning the bedplate monitoring system a HLS bedplate display was integrated in the ATLAS control system in collaboration with PH/ADO. See below a schema of the HLS installation(L) and results in 2010(R).

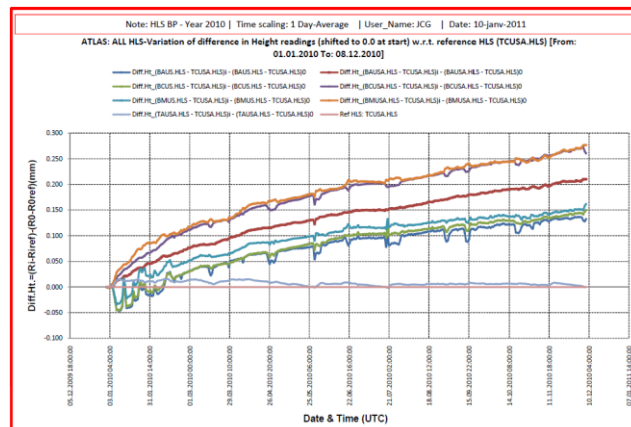
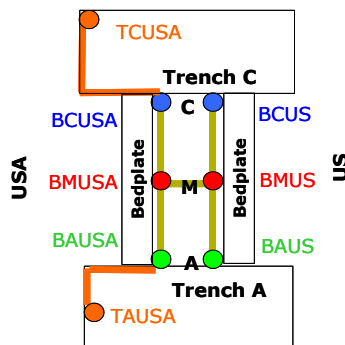

CMS: The position of the beam pipe parts, located in the range of 10 to 16 m from the IP, was measured. The CMS closure process surveys were done to track and position the moving detector parts as the YEs, HFes, Castor table. The TAS position was controlled. SU participated actively to the CMS Engineering Data Base work in collaboration with the CMS integration team. Characteristic points were defined for each detector or detector part. Data was prepared for different CMS construction epochs from the relevant survey data published during the CMS assembly.

ALICE: All the pending survey reports concerning previous survey measurements were written. The preparation of the long Technical Stop was actively done mainly to prepare the MCAL installation.

LHCb : The stability of the Be beam pipe section 3 support element in the dipole magnet was controlled under vacuum and atmospheric pressure. Surveys of the Muon Walls and RICH2 HPD frames were done.

## **LINAC 4:**

### **BE-ABP Group**

After measuring the emittance of the Linac4 RF ion source, it was converted to 45kV operation. However, the source could not generate beam at this energy, when igniting the plasma with the high voltage applied, a breakdown rapidly occurred.

The development of a RF driven plasma generator, as the precursor of an ion source for the high repetition rate, continued thanks to funding from the EU. The design of the generator was finished, and production and assembly were completed around the end of 2010 allowing the production of the first plasma. Due to modeling of the eddy current flow in the permanent magnets around the source plasma chamber, a copper shielding system was developed to mitigate the heating of these magnets beyond their Curie temperature.

The network has been transferred from the surface down to the tunnel level twice. The first transfer was to enable controls of the civil engineering works to be carried out; the transfer was then repeated at the end of the year as part of a campaign to establish the network ready for the installation of the infrastructure. A scan has been done to enable the “as built” situation of the klystron gallery and of the tunnel. The alignment of the components of the 3MEV test stand was continued. The metrology of the PIMS prototype was achieved, and the DTL prototype was re-measured as a dimensional control.

### **BE-BI Group**

During 2010 the work for Linac 4 instrumentation was subdivided into two parts: measurements on the 3 MeV test stand, where the first Linac 4 instruments have been tested; preparatory work for the 3-12 MeV diagnostics test bench and for the new Linac itself.

At the beginning of the year the Linac-4 source delivered H<sup>+</sup> ions initially at 35 KeV and then at 45 KeV. Unfortunately problems with high electron currents causing damage to the electron dump forced source operation to be switched to proton mode. The instrumentation currently installed, namely a Faraday Cup and emittance meter, can handle both cases. BI were therefore able to continue commissioning of the emittance meter and provided the source commissioning



team with a dedicated software application to efficiently interpret the emittance measurement results.

In preparation for the 3 MeV diagnostics test bench, the design of a new slit for the emittance meter has been completed, with production underway. It will be capable of withstanding the impact of a full source beam at energies up to 12 MeV.

Most of the instrumentation for the 3 MeV measurement line, to be installed after the RFQ, is also ready. The bunch shape monitor, built at INR Moscow, has arrived at CERN, and the beam current transformers are already installed. Detailed electro-magnetic simulations of the strip-line detectors that will be used for beam position, beam current and time of flight monitors have been completed for both the test bench and the Linac 4 devices. The monitors are now in production. Design of the SEM grid and Wire Scanner detectors to be installed in the diagnostics test bench and in the Linac 4 tunnel has been completed with production soon to be launched.

## **BE-RF Group**

### **Linac 4 RF Structures**

In 2010 the fabrication of the first out of three modules of the Linac4 RFQ was completed. A second module was assembled and prepared for its first brazing (two brazing steps are required for the fabrication of each module) to be performed in January 2011. The collaboration with CEA, in the frame of the French contribution to the Linac4 project, has produced important results coming from the low level RF measurements of the RFQ modules at different phases of their fabrication. These measurements have confirmed the good quality of the fabrication process and have contributed to the validation of the fabrication procedure. The present schedule envisages the delivery of the three RFQ modules assembled together in September 2011 and possible start of the RF tests in November 2011.



**The first module of Linac4 RFQ after the second brazing step.**

The DTL prototyping was completed with a drift tube containing a permanent magnet quadrupole (PMQ). Further high power tests of the DTL prototype, using this drift tube and a number of different PMQs in the end wall, have demonstrated the voltage holding capacity in the presence of magnetic fields. Meanwhile, the drawings of the DTL tanks have been completed and the drift tube mounting mechanism has been patented.

On this basis a collaboration agreement with ESS-Bilbao has been reached with Bilbao contributing the manufacturing of drift tube parts in compensation for access to the DTL technology. Price-enquiries for the manufacturing of tank and girder segments have been run such that series production can start in 2011.

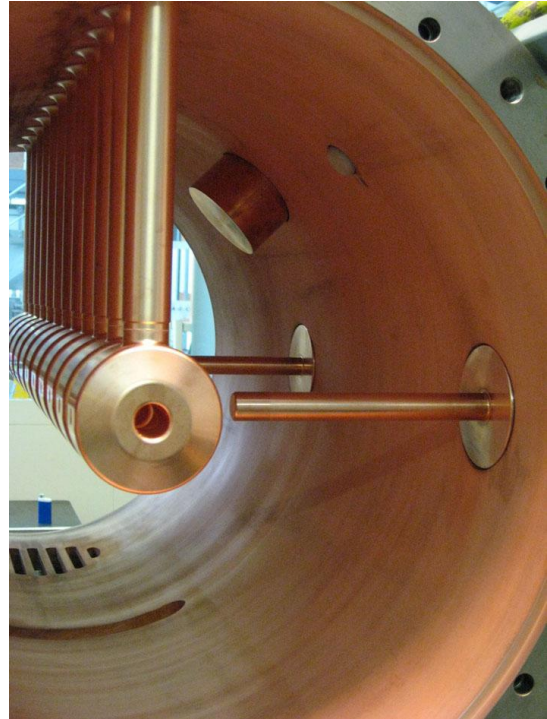

**DTL prototype cavity assembled with drift tubes, tuners and post couplers.**

The construction of the CCDTL was started in Russia, involving VNIITF in Snezhinsk for the fabrication of the tanks, and BINP in Novosibirsk for the drift tube manufacturing and tuning of the modules. The first modules are expected to arrive at CERN in autumn 2011 and will be mounted and aligned by a team of Russian scientists.

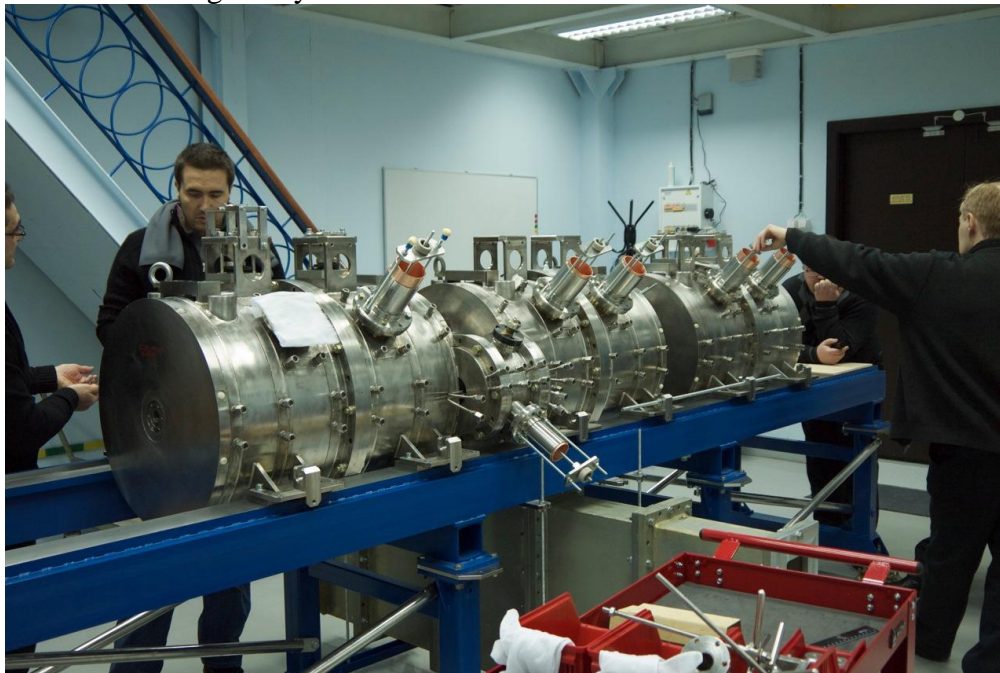

**The first CCDTL module being assembled on the test bench in Novosibirsk.**

In summer 2010 the machining, tuning and final electron beam welding of the "hot" PIMS prototype was completed. At the same time, a cavity-to-waveguide coupler prototype was designed and built. Together they were tested in a bunker, temporarily installed in the 3 MeV test stand. The conditioning went extremely well and within 30 hours the full Linac4 pulse specifications had been reached (1 MW peak power, 0.8 ms flat top length). This confirmed successful functioning of both the PIMS and the coupler. Towards the end of 2010, both items were tested in SM18 with high average power (85 kW), to make sure that they were indeed compatible with high duty cycle operation (10%) for which everything is designed. The measured temperatures agreed well with simulation results, fully validating the design concept. The PIMS prototype will be used as the first cavity in the Linac4 PIMS section. The series production of the PIMS will take place in collaboration with the Soltan Institute for Nuclear Physics (IPJ) in Poland and Forschungszentrum Jülich (FZJ) in Germany, starting in the beginning of 2011.



**The PIMS prototype cavity shown at the 3 MeV Test Stand at CERN inside the bunker where it was tested with RF power.**

2010 also saw the preparations for auxiliary equipment needed for the Linac4 accelerating structures, e.g. movable tuners, to be constructed within a collaboration with INFN (Italy), support structures and alignment jacks, wave-guide couplers that are expected to be constructed in India, wave-guide windows for which tendering was launched towards the end of 2010 and for which a CERN internal prototyping was also launched.

In early 2010, an order for five solid state amplifiers, including two as part of a French in-kind contribution, was launched. These units will be used for the three buncher cavities in the Linac4 MEBT and the debuncher cavity in the transfer line. In collaboration with CERN the first 9 kWatt sub-unit was developed and tested successfully in July, fulfilling Linac4 specifications.



Early December two complete 33 kWatt units were ready and successfully tested and at the same time the control interface was finalized. The project is on schedule to be delivered to CERN in the spring of 2011 for integration in the 3 MeV test stand.

### **Linac4 high power RF:**

In 2010 the layout of the Linac4 high power system was finalized: this comprises the high power equipment and the power distribution system, the cabling, the water cooling distribution as well as the interfaces with other systems. The specification document for the new 2.8 MW klystrons was completed and the contracts with two firms were placed. The specification documents for the RF loads, the RF drive amplifiers, the folded magic tees and the focusing power supplies were also completed and the tendering procedures launched. The design of the klystron high voltage gun tank was finalized and the construction of the prototype started.

The installation of the two new Linac4 test places, in B112 for the high power equipment, and in SM18 for the RF structures, has also started:

- the B112 test stand will be equipped with a completed (incl. controls) Linac4 type high power system. It will be used to validate the power distribution design and the individual components, to perform acceptance tests of new equipment and to retune the LEP klystrons.
- the SM18 will be dedicated to RF structure tests, in particular the CCDTL's and the PIMs.

2010 also saw the preparations for auxiliary equipment needed for the installation of the high power system in Linac4: the specification document for the waveguide is in preparation; the waveguide support system was designed and built, the installation is expected to start in Mai 2011. Prototyping of auxiliaries' equipment (e.g. arc detectors, circulator control units) was launched.

## **CTF3/CLIC:**

### **BE-ABP Group**

For the CDR, a lot of progress was made concerning the feasibility of the CLIC facility from the pre-alignment point of view. The solution of the overlapping wires used as a reference for the active pre-alignment was validated using data from our experimental area in TT1 and Montecarlo simulations. Promising results show that the accuracy obtained is within 11  $\mu$ m in V and 17  $\mu$ m in H (radial). From the point of view of the geoidal undulations determination, which provides our vertical reference surface, the accuracy obtained was better than 20  $\mu$ m. Further measurements and analysis are required to show if the undulations observed are real. A new prototype instrument (a "deflectometer") is being prepared to potentially measure the deflection on the vertical differences directly in the tunnel. Concerning the earth tides studies, corrections of the HLS data can be done properly and predictions are also understood.

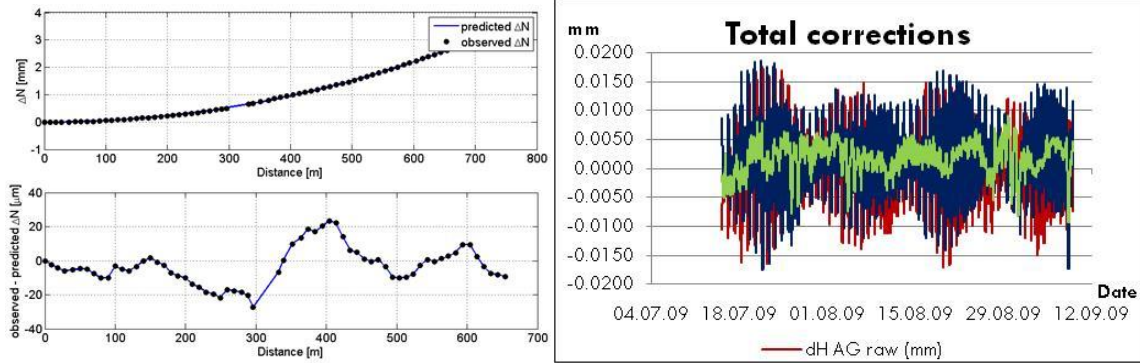

Geoidal undulation and tidal effects

The fiducialisation process was much investigated this year. An inventory of all the existing solutions was done, many measuring machines were tested (portable CMM, measuring arms, laser trackers, etc) and the problem of linking the sensors located on a girder to the mechanical axis of the magnets is well under control. For the adjustment system, the concept of CAM movers and linear actuators were also approved and will be validated next year on two mock-ups. All this work was summarized in the SU contribution to the CLIC Conceptual Design Report.

For the TDR, an optical Wire Positioning Sensor is under development with the collaboration of Brandeis University. A laser based alignment system will be studied and tested by a student from spring 2011. The collaboration with NIKHEF has been reactivated in three different directions: the first one deals with the proximity network, the second as a backup solution to replace the overlapping wires and the third concerns the monitoring of the Q0 on each side of the experiment.

## BE-BI Group

The preparation of the CLIC Conceptual Design Report has required a non-negligible effort from the beam instrumentation team in 2010. Parameter specifications were produced for every type of instruments and most of the feasibility issues have now been addressed, with several detectors studied in detail. In particular, the effort on the CLIC BPMs was significantly increased in 2010 with a very fruitful collaboration with Fermilab leading to the design and start of fabrication for a prototype low Q cavity BPM. This cavity BPM, foreseen for the main beam, is designed to have a resolution  $< 50\text{nm}$  and an absolute accuracy better than  $2\mu\text{m}$  (see picture). For the drive beam BPM collaboration with SLAC has been just as successful, with the fabrication of

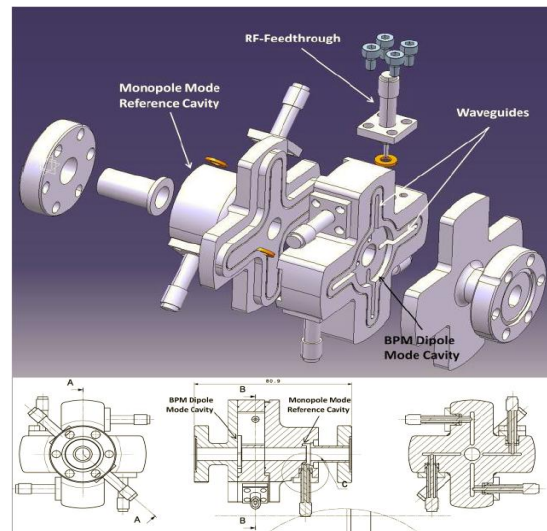

one prototype BPM also started. For these BPMs the requirements are less stringent with an absolute accuracy of 20um and resolution of 2um, but for a much larger quantity (~40000). Both prototype BPMs will first be tested in the laboratory before undergoing beam tests in CTF3.

Completion of the CTF3 complex instrumentation is also on a good track most of the beam diagnostics in the CLIC experimental Area installed. The experimental demonstration of the drive beam frequency multiplication scheme with high bunch charge is one example of the excellent results achieved in 2010. A new streak camera with an ultimate resolution of 500fs was bought and put in operation to study this scheme. The picture below shows measurements of the frequency multiplication in the CTF3 combiner ring using the new streak camera. In four consecutive turns, the initial beam frequency (3GHz) is multiplied by a factor 4 to obtain the 12GHz required for the drive beam decelerator.

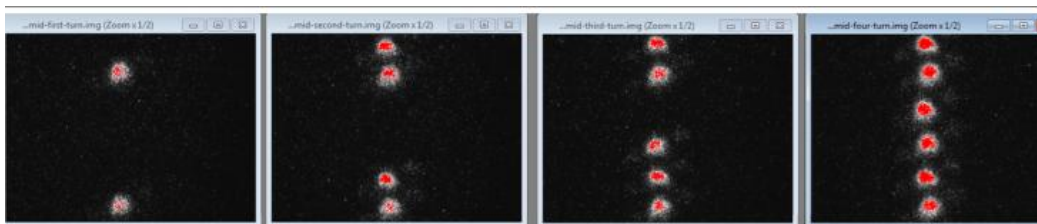

## BE-RF Group

In finalizing the design for the conceptual design report, a number of different design changes have been made to mitigate collective effects, including a reduction of the RF frequency from 2 to 1GHz. The beam will now consist of two half-trains that circulate on the opposite sides of the ring and will be merged after extraction. These changes allowed reducing most collective effects to a level comparable to other machines.

Because of its high quality, the CLIC beam will be very sensitive to dynamic imperfections; in particular the motion of ground and small variations in the timing between the main and drive beam are of concern. The beam quality and hence luminosity will be maintained by a combination of measures. They include the active and passive mechanical stabilisation of the CLIC quadrupoles and beam-based feedback and feed-forward. Fully integrated studies of the ground motion and the different mitigation techniques have been performed. They include realistic ground motion modelling as well as realistic simulation of the behaviour of the mechanical system as developed by the CLIC stabilisation team in EN-MME. An optimised and robust beam-based feedback has been developed, which achieved satisfactory performance with the currently demonstrated hardware. Based on the conclusions of these studies, the CLIC stabilisation team developed a concept of a new mechanical system that will vastly improve the beam stability and will be tested in the future.

The beam delivery system (BDS) of CLIC will focus the beam to the extremely small vertical r.m.s. size of 1 nm. This year the tuning of the BDS with realistic imperfections has been studied. Using simulations, a tuning strategy has been developed, which achieves satisfying performance. Further effort is ongoing to improve the final luminosity and to reduce the large number of

tuning steps from about 10000 to a few hundreds. Tests of a low energy version of the BDS have been performed in ATF2 at KEK. A very small beam size of 300 nm has been achieved but further effort is needed to reach the target of 37 nm which would scale to the 1 nm target for CLIC. Studies at CERN showed that some of the magnets in ATF2 will need to be replaced to reach the above target. In parallel, important progress has been made on a modified BDS design for CLIC that would improve the experimental conditions in the detectors.

### **CTF3**

The progress on the commissioning of CTF3 and the demonstration of the CLIC feasibility was slowed down at the beginning of 2010 due to a modulator fire and its consequences which led to a 4-month delay in the experimental program. Nevertheless significant progress has been made during the year towards the feasibility demonstration. The drive beam was generated with a combination factor 8 using the delay loop and the combiner ring and was delivered successfully to the CLEX area for experiments in TBL (test beam line) and the TBTS (two beam test stand). This beam which had a maximum of 17 A in CLEX was sent through the entire TBL line at up to 50 MW of 12 GHz power have been extracted by the prototype PETS (Power Extraction and Transfer Structure), as predicted. Three more PETS tanks for TBL have been assembled during the year and installed during the winter shutdown. Two of these tanks have been assembled in the SM18 clean room to study the effect of clean assembly on the conditioning process; the third one has been assembled by CIEMAT in Spain within our collaborations. The PETS in the TBTS produced up to 200 MW of 12 GHz power using a power recirculation loop. The highlight of the two beam area was the successful acceleration of the probe beam (CALIFES) with a gradient of 100 MV/m using a prototype CLIC accelerating structure.

The beam stability in the CTF3 was investigated and the intensity was found to be stable below  $10^{-3}$  which fulfills the CLIC specifications. This was possibly due to additional feedbacks to stabilize the klystron and pulse compressor temperatures in the Gallery.

All RF systems, klystrons, modulators and low level systems worked very reliably during the year with good results despite the time lost due to the fire.

### **Photo Injector PHIN**

The PHIN photo injector was operated during two short periods in 2010 and demonstrated most of the required beam parameters. The long bunch train of 1908 bunches with 2.33 nC charge per bunch was generated and accelerated successfully including beam loading compensation. The beam size, emittance, energy and energy spread were measured and time resolved demonstrating the stability of these parameters along the train. All measured beam parameters are within the specifications. The shot-to-shot stability of the beam intensity was found to be 1 % which is excellent for such a system but still needs to be improved by a factor five to meet CLIC requirements. The aim is to achieve this with a laser intensity feedback. This is to be tried in 2011, making use of the phase-coded beam using electro optical modulators to switch the phase of the laser beam. The PHIN program is done together with EN/STI who is responsible for the laser and the cathode production. The original objectives of the PHIN experiments would then be basically achieved, and the facility ready to be used to study the photo injector option for the CLIC drive beam.



### **Stand-alone 12 GHz RF power source**

A stand-alone 12 GHz power source has been developed in collaboration with IRFU/CEA for high power RF testing of CLIC prototype accelerating structures and components. The solid state modulator purchased by Saclay has been delivered and preliminary acceptance testing has been done at CERN. The 12 GHz 50 MW klystron itself designed and constructed by SLAC was delivered. The system was put together at CERN with the help of SLAC experts and first high voltage pulsing was performed before the end of the year. It turned out that the modulator and its oil tank needed some rework before real commissioning of the test stand can be started therefore it is expected that the test stand will only be commissioned during summer 2011. During the year the low level drive and diagnostic system for the test stand has been built and installed. A sophisticated control system for automatic conditioning of accelerating structures has been developed and is ready to be commissioned.

## **HIE-ISOLDE:**

### **BE-ABP Group**

The alignment challenge is to monitor in warm and cold (4K) conditions the relative position of the Cavities and of the Solenoids which will take place inside each cryo-module and to define their position with respect to a common nominal beam line. A system based on BCAM electro optic instrumentation and optical fibers was proposed. Simulations and preliminary tests were performed, a test bench is under construction in collaboration with TE/MSU and integration of such a system in the design is under study.

### **BE-RF Group**

The High Intensity and Energy ISOLDE (HIE-ISOLDE) project is a major upgrade of the existing ISOLDE and REX-ISOLDE facilities with the objective of increasing the energy and the intensity of the delivered radioactive ion beam (RIB). This project aims to fill the request for a more energetic post accelerated beam by means of a new superconducting (SC) Linac based on Quarter Wave Resonators (QWRs). The cavities are niobium sputtered copper; this brings operational advantages and reduced cryogenics requirements, but is technically more challenging in manufacture than bulk niobium cavities.

2010 saw the RF group becoming heavily involved in the HIE Isolde project. With the cavity design completed the project was now at the stage of construction of a first prototype cavity. SM18 infrastructures and facilities were being upgraded in preparation for cavity assembly and RF testing. The existing Class 100 clean room was heightened and the vertical test cryostat V5 completely refurbished and equipped with a new control system. The RF group participated in the fabrication, clean room preparation and coating of this first cavity. Since the infrastructure upgrade could not be completed in time, this first cavity was tested at TRIUMF. However, its performance was well below that expected and it became clear that a sustained program of refinement of the fabrication and coating procedures and RF testing would be needed at CERN. A second prototype cavity was delivered in December 2010.

## **SPL:**

### **Scope of the SPL study**

Following Chamonix 2010 and the review of the new injectors complex renewal with PS2 and a Low Power SPL (LP-SPL), the LHC injector project (LIU) now focuses on the upgrade of the existing injectors (PSB, PS, SPS), working with Linac4. The CERN management nevertheless decided early in 2010 to support continuing R&D for a high-power SPL (HP-SPL) matched to the needs of neutrino facilities. The SPL study will finish with a design report in 2011 and the SPL team now concentrates on specific hardware R&D and non-site specific layout issues. The SPL design report will therefore also address all design considerations for the HP-SPL.

### **BE-RF Group**

Work was started on the detailed design of the cavity shape and on its integration with its ancillaries (e.g. tuner, power coupler, HOM coupler port) into the cryo-module. This work is supported by German and UK institutes. It also includes construction of a copper cavity model. Studies were also done on HOM damping requirements, cryogenics needs and mechanical design.

The first stage of the design of the fundamental power coupler was completed and the prototyping started. The coupler construction plan includes eight SPL-LHC couplers, of two different types. These will be assembled at DESY and tested at CEA Saclay in 2011. Infrastructure requirements for preparing and assembling high gradient cavities and couplers were assessed, with the help of outside experts. An upgrade plan to bring CERN SM18 facilities to the necessary level was established.

Major progress was made on the definition of the RF powering layout, the selection of the type of power sources and the physical location of the equipment. Baselines were defined for powering the cavities in both LP and HP SPL. IOTs or phase-locked magnetrons were identified as promising solutions, even though both options would still require substantial R&D. Solid state amplifier solutions were also studied for the low energy part of the linac.

The implementation of the SPL high power test place in SM18, and in particular the installation of the big 50 Hz modulator was studied. In order to maximize the free space for the 50 Hz modulator installation it was proposed to dismantle and move the LHC high voltage bunker to the other side of the high power zone. The refurbishment of the vertical cryostat V4, dedicated to the SPL cavity tests, was also started. It should be completed in 2011. The planning is tight, constrained especially by Linac 4 works, but was considered feasible. A decision on whether to take an existing 1 MW design or a new higher power klystron will be made early in 2011. The possibility of a common order together with ESS was also looked at. The RF power distribution layout in SM18 was studied in preparation for a final decision in spring 2011 on the choice of common or separate circulator for each of two cavities powered.

Specifications for klystron modulators, cavity tuning and waveguide matching systems were made. The SM18 modulator, provided by ESS, is on track; the order is to be placed in 2011 for delivery in October 2012.

Simulink models of the cavities were created to simulate system and hardware imperfections and to optimize feedback parameters. It is hoped to validate the LLRF simulation results by building a complete control system to be tested on a cold cavity at CEA Saclay.

# COLLIMATION PROJECT

## ABP Group

The performance of the installed collimation system was outstanding thanks to the preparatory work and the setting up sessions with beam, with impressive cleaning efficiencies achieved. The performance of the collimation system with ions confirmed the new features anticipated due to fragmentation. In parallel, the activities devoted to the upgrade of the current system progress. In particular, it is worth mentioning the optics work for the proposed new layout for the dispersion suppression in IR3, where some dipoles and quadrupoles will be displaced by as much as 4.5 m to provide more space for the so-called cryo-collimators.

## LHC Luminosity Upgrade

### ABP and RF Groups

#### LHC upgrade (Phase I, HL-LHC, HE-LHC and EuCARD)

The optics and layout of the so-called Phase I insertion upgrade was finalised (SLHCV2) and fully documented together with the field quality specification of the new triplet and D1 magnets and the first assessment of the obtained solution in terms of beam-beam effects. Several optics limitations that were identified during the Phase I project were presented and discussed in detail at the Chamonix 2010 workshop and by the LHC Upgrade task force set up after the workshop. These discussions constituted key ingredients for the decisions following the long-term strategy plan for upgrading the LHC machine. In order to overcome limitations such as aperture, optics flexibility and correct-ability of the chromatic aberration at low beta\*, and to reach very small beta\* values as well as different beta\* aspect ratio (flat optics), a new concept based on an Achromatic Telescopic Squeezing (ATS) principle was proposed. This new scheme was implemented in the third version of the optics and layout of the SLHC (SLHCV3) and fully documented. This new approach will certainly form a solid basis for the HL-LHC Project, which was launched in 2010. In this context it is worth mentioning the joint LARP-EuCARD LHC Crab Cavity workshop in December 2010, the fourth of the series, where a realistic optics and layout based on the ATS scheme was presented and the progress in the field reviewed.

After Chamonix 2010, it became clear that also the strategy towards the LHC Luminosity had to be optimized. In this context the project HL-LHC (High Luminosity LHC) was defined and initiated. The definition of the FP7 Design Study, which covers a significant fraction of this project, was formulated in a record time from initial ideas in July to the successful submission to Brussels in November.

The key building blocks to the HL-LHC are 1) Larger aperture advanced Nb3Sn quadrupoles, 2) Crab Cavities that tilt the bunches such that even with a non-zero crossing angle the tiny bunches collide fully 3) Improved collimators apt to handle the large beam energy and 4) Power feeds based on High-Temperature Superconductors that would allow to separate power converters from magnets and thus making space in the tunnel and the caverns.

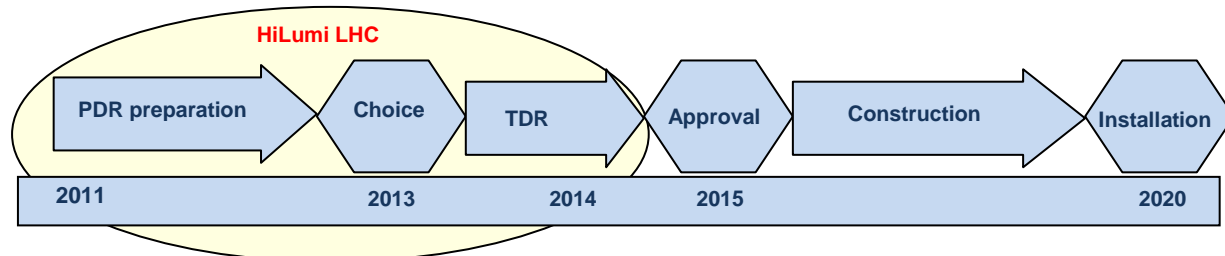

**Timeline of the HL-LHC project, with the two main decision points: end of 2013 and 2015, enabling installation in 2020. “HiLumi LHC” is the FP7 Design Study through the initial period of HL-LHC.**

### **Other LHC upgrade activities (HE-LHC) and EuCARD**

Other paths to the upgrade of the LHC performance were studied in parallel, such as crab-waist optics, large-Piwiniski angle schemes, parameter optimization, long-range compensation, and crab cavities. The joint LARP-EuCARD LHC Crab Cavity workshop in December 2010 was already mentioned. Concerning other EuCARD activities, several other workshops were organised or co-organised, such as Channelling 2010, the Annual Workshop on Crystal Collimation, and, in particular, HE-LHC'10 - the first Mini-Workshop on a High-Energy Large Hadron Collider. The ABP group contributed to the HE-LHC working group at CERN, and to the first CERN report on this topic.

### **Laser Scanning**

In the frame of the 3D reverse engineering for experiments, many laser scanners were tested at CERN. Two families of instruments were identified:

- The “integration” ones are measuring quickly and automatically a big volume with an accuracy of several mm. They could be used for integration of new detectors parts inside existing ones, for the “as built” scans of accelerator components and even for mobile “scanning” in CERN building or tunnels.
- The “metrological” ones are to be used manually, like a paint brush, on smaller objects but their accuracy is in the range of tenths of mm. This type will be interesting for CERN when the time of assembling new detectors for LHC upgrade will arrive.

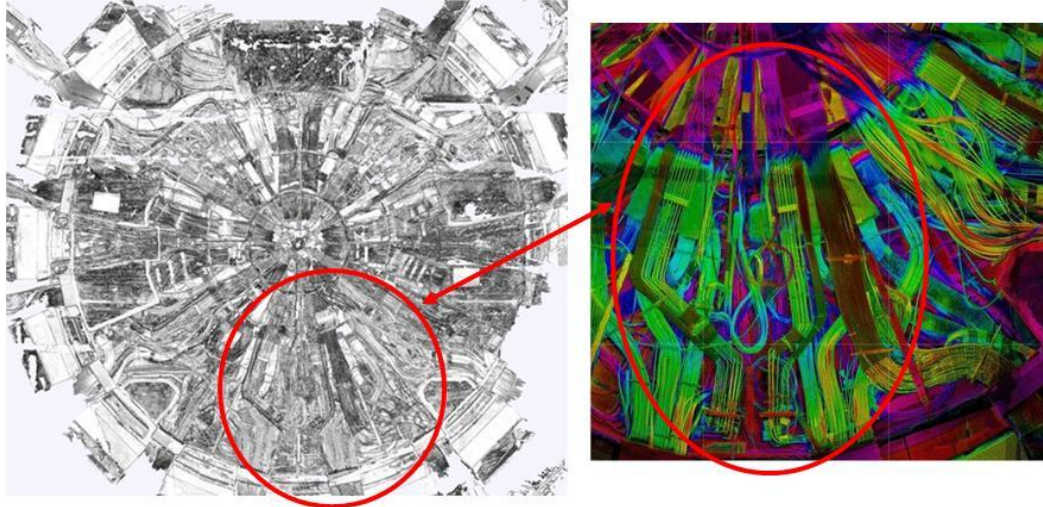

image treatment of Atlas detector

A lot of progress was done in the use of the Geomegaic Software to clean the cloud of points, realize the mesh and modelize objects.

## LHC Injector Project Upgrade

Following Chamonix 2010, the LHC injector project (LIU) has been mandated to optimize the upgrade of the existing injectors to enable the reliable delivery of beam to the LHC through the injector chain (LINAC4, PS Booster, PS and SPS) and the heavy ion chain. In 2010, the Project Management has been working on a feasibility report and cost estimate for the PS Injector, transverse emittance measurements from the PSB to the SPS, electron cloud in the SPS, the possibility of connecting Linac4 to the PSB during the first long shutdown in 2011 and beam characteristics at LHC injection.

## LHeC

### ABP Group

Major contributions were made towards the design of ring-ring and linac-ring collider versions for the LHeC, and the pertinent LHeC conceptual design report. The work includes optics designs for ring, re-circulating energy-recovery linac, and final focus region, the interaction-region design with three beams, and an assessment of beam instabilities in the re-circulating linac-sources required for such a collider.

### RF Group

Studies were done on the Superconducting RF systems for the ring-ring, linac ring and Energy Recovery Linac (ERL) options and presented at the Divonne-Les-Bains LHeC workshop in

November. The frequency chosen for all of these systems was decided at 720 MHz. This choice allows synergy with ongoing SPL SC cavity prototyping at 704 MHz and with the BNL eRHIC proposal. The cavity design and RF power systems are however substantially different for each option. Work continued towards preparation of the LHeC CDR in 2011.

## **Accelerator Controls Renovation Project (ACCOR)**

### **BE-CO Group**

Officially approved in 2009, this project has the objective to renovate the control system of all CERN machines, hardware and software wise, LHC excluded. Major technical decisions have been taken this year concerning the future front-end processor platforms and large-scale commercial contracts have been put in place with the help of the CERN Finance department. After an initial integration phase, a first set of prototypes has already been installed in operation for validation. With more than 500 front-ends to be renovated, this project is a big challenge in terms of strategy and priorities for the different departments of the A&T sector. The main focus in 2010 was the development of the core controls components (hardware modules, generic software classes). Development systems have now been given to the equipment groups of the A&T and prototyping work has started on all fronts. The first massive operational deployments are foreseen during the 2011-12 shut-down and during the long LHC stop in 2013.

## **InCA Project**

### **BE-CO Group**

For the InCA project, the first part of 2010 was focused on the preparation of a 2-day machine development (MD). This MD aimed at the final validation of the system before the first operational development in the PS machine. Following the results, the deployment date was officially set to the last week of June. A core team of ten persons from both the Controls (CO) and Operation (OP) groups came early in the morning of the 30th of June for the final deployment and, by 8:30, InCA was deployed and controlling the entire PS machine. Since then, the performances of the system have been very good accounting for only few hours of downtime in more than five months of 24/7 operation. A support team has also been put in place to help the operators and machine experts with the use and commissioning of the system. In parallel to the work on the PS machine, the LEIR machine was also upgraded to the latest version of the InCA software suite.

The LHC-SPS-LEIR beam steering application, 'YASP', has undergone significant adaptations to cover PS specific features. Along with the upgraded orbit measurement instrumentation, YASP has been successfully deployed in operation in PS Ring and TT2 for both proton and ion beams. It has also proven to provide further functionalities and correction schemes. This validation has led to the decision to eradicate the previous ABS software suite and its underlying instrumentation.

# Cross Departmental Activities

## BE-ABP Group

**Computing:** A new version of LGC++, the SU adjustment software, was put under production, and development is continuing on some of the mathematical models. The transformation modules between the CERN Co-ordinate System (CCS) and French and Swiss reference frames have been added to CSGEO. This application has been provided to the GIS team and the Reference Database team. For integration of scans, some other transformations between the CCS and local CAD survey systems were also determined.

**Database:** After modification to the data structure, the writing of the new Geode interface in APEX has started. The work on frame tools and mechanism as well as on a Web service has made important progress. The new Geode portal is nearly ready.

## BE-CO Group

### The LAFS-BE/CO collaboration

The LAFS (LHC at Fermilab Software) collaboration between BE/CO, BE/BI, BE/OP and Fermilab continued throughout 2010, bringing several new applications into life. The LHC Schottky suite is the most recent deployment of the collaboration. The software was developed by a team hosted at Fermilab using the BE Controls software stack. They were progressively deployed within the Controls infrastructure with a help of our developers. Both ends of collaboration communicated smoothly thanks to a new Fermilab liaison, Terri Lahey. Schottky suite is now entering an operational stage and will be maintained by BE/BI members.

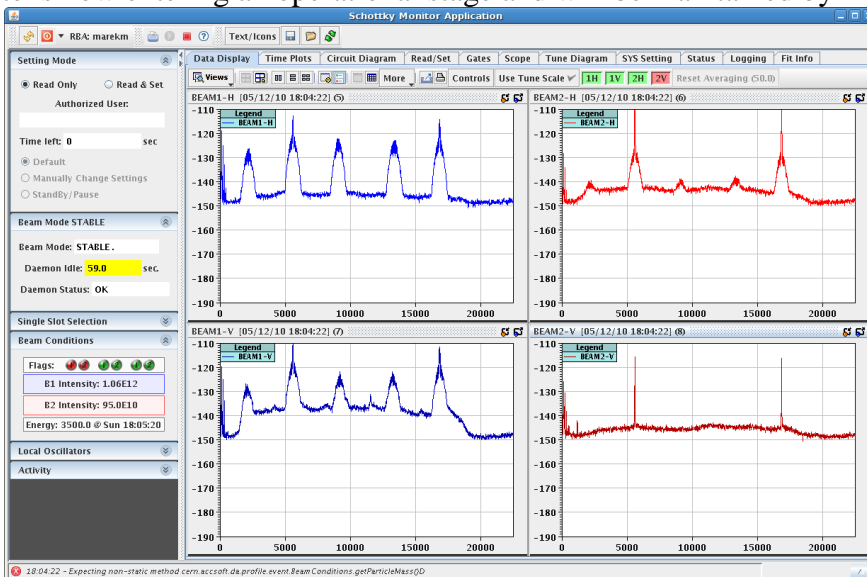

### LHC Schottky client GUI

### Controls Configuration

A significant amount of development effort was devoted to the most central database of the controls system, the Controls Configuration database. The major aim is to fully embrace the



paradigm shift towards the new front-end software architecture (FESA) by making the design and development tools, related to the Controls devices models, fully data driven.

New functionality and improvements, driven by the numerous requests of the user community have been provided concerning all configuration areas: controls hardware, middleware, operator's consoles, fixed displays, etc. A dedicated set-up has been made available for the new controls test-bed. The integration with diagnostics and monitoring (DIAMON) is improved, as well as data propagation to the operational settings database (LSA).

### **Alarms Data Management**

The data flow into the Alarms database from the different providers has been streamlined in order to optimize the management of close to 200'000 alarm definitions.

Public browsing and authorized data manipulation access via a homogeneous suite of interactive interfaces has been provided to the community of alarm users. This is essential, especially for the operators taking care of the technical infrastructure.

### **Accelerator layouts**

The layout database has become an essential information hub with respect to the accelerator installations. It pursues to cover not only machine layout, electrical circuits and control system electronics, but federates also information from other data sources: equipment travelers (MTF), detailed equipment databases (TE-MSD, TE-EPC) and installation photographs (EDMS). The strategy to continue capturing the layout of the complete accelerator complex has been endorsed by the department heads in the accelerator and technology sector. For Linac4, the Linac4 transfer line and TT66 (HiRadMat), the proactive approach to describe future installations during their design phase in the layout database has undoubtedly paid off.

### **Control Room Infrastructure**

The 110 operational consoles in the CCC have been upgraded to very powerful PCs based on Intel Core I7-860 @ 2.80Ghz with 8Gb of Ram, 250Gb of local disk and 1 Gbit Ethernet connection. LEIR, ISOLDE and CTF local operation rooms have also been upgraded with more recent PCs.

On the backend side in the CCR almost all old ProLiant servers have been replaced by blade servers, each one based on 2xIntel Xeon Gulftown @ 2.80Ghz with 12Gbytes of Ram, 8x300Gbytes of local disk and 4 Gbit/s Ethernet connections.

Four new 46" wall screens were installed in the SPS bay.

### **Common Middleware and RBAC**

Several MW releases were introduced in 2010, to correct or enhance the communication software suite. In addition, our JMS brokers' infrastructure has been reviewed and optimized to offer a better service to the user community.

The Proxy service has been extended to the majority of LHC equipment systems (BI, Collimators and BT) & part of PS & CTF. Proxies help to serve the high demand for data from poor hardware front-end machines (LynxOS) by reducing drastically the connections to the devices.

## **DIAMON and LASER**

LASER has been used in everyday operation as in the previous years. Apart from normal maintenance, the focus was put on consolidation and improvement of the graphical user interface especially implementing a 'panic' mode where the GUI is started while access to the LASER server or Database is not available. The LASER team also deployed a new gateway for the IT network alarms, implemented an RSS interface to read the alarms and enhanced the LASER database web portal in collaboration with the Database section to facilitate the end-user interactions

The DIAMON diagnostic and monitoring suite was used in operation for all accelerators in 2010. Its new facilities to detect errors in the controls infrastructure and the tools to repair/reset or reboot the devices were very well received from the operation crew. The main features added to DIAMON in 2010 are the error filtering, the restart of the local agents or the search for a computer given a process name. In addition, users can easily subscribe via the DIAMON GUI to notifications about their devices and they can also enable regular status report.

## **Computer and Network Security**

The security of our infrastructure has been enhanced by integrating the new LDAP, by having a strict management of the authorized users, by changing the operational accounts passwords every 6 months or by a centralized handling and managing of the system files (e.g. password, hosts, hosts.equiv, nfs-mount, ...).

In 2010 an initiative was launched to build a web-based questionnaire to identify all devices connected to the Technical Network with the goal of understanding all inter-dependences between systems and also to assess the global security of our controls infrastructure. A first version of this questionnaire is available now and the first results will be exploited by mid-2011.

## **Virtualisation**

Our VMWare virtualization infrastructure has been migrated towards a Microsoft Hyper-V infrastructure. The IT department is managing powerful servers running Hyper-V, each one hosting up to 10 virtual machines. These virtual machines are running either Win-7 or SLC5 and are used by all developers using our Controls Infrastructure. As of today, more than 250 Virtual Machines have been deployed.

## **Hardware developments**

The focus in 2010 was on the development of three FPGA Mezzanine Card (FMC) carriers and mezzanines. Carriers were developed in two formats: PCIe (low-cost and high-performance versions) and VME. The latter was in fact designed in BE-BI in close collaboration with the BE-CO-HT team. The main effort on the mezzanine front was on the 100 MS/s 4-channel ADC with oscilloscope-like analog front end, featuring a programmable offset and sensitivity. Prototypes for these four boards were received and showed promising behavior upon initial power-up. The collaboration with other groups in design tasks was fruitful and shows a promising outlook for the future.

Another important development was version 2 of the White Rabbit switch, demonstrated in the ISPCS 2010 plugfest as an Ethernet switch fully compliant with the IEEE 1588 Precision Time Protocol (PTP) standard.

Finally, 2010 was also a key year for the development of NanoFIP, the FPGA-based radiation-tolerant alternative to the MicroFIP chip. The VHDL was completed and ready for review, and a

prototype board tested the NanoFIP over Christmas executing more than 24 million cycles without a single failure.

### **Device Drivers**

The main focus this year was the migration of existing LynxOS/CES drivers to an Intel-based Linux platform. The main areas covered were the VMOD family of mezzanines (simple digital and analog I/O) and the IP mezzanines for serial links (RS232, RS422 and RS485). In addition, the SIS family of high-speed VME samplers was also migrated, and the new CVORG fast VME analog waveform generator was fully supported for the MEN A20 Linux platform.

Another important area was the adoption of a quality-oriented development process inspired by the one used in the Linux kernel. Git version management and patch submission with a benevolent dictator model were tested successfully in the second part of the year and have now become the norm.

### **Timing**

The main theme of the year was the consolidation of the LHC central timing, which involved mainly the development of a complete test bed in the laboratory, along with the inclusion of logging of all central timing activity for diagnostics. In addition, a large refactoring effort was undertaken and successfully deployed.

The injectors' central timing facility saw the arrival of the new HIDRADMAT beam, for which special developments were necessary. In addition, a new central timing system for REX-TRAP was designed, developed and deployed successfully.

On the distributed timing front, polling of users started for Linac 4 and resulted in a preliminary design. In addition, many legacy TG8 modules in the injector complex were replaced by CTRV modules under the new MEN A20 Linux platform.

### **Front-ends**

The reliability and performance of the LHC controls infrastructure was again excellent in 2010. With more than 40,000 device instances deployed on more than 400 front-end computers, the Real-time Front-end Software Framework (FESA) developed by the control group became in CERN-wide de-facto standard for the development of Accelerator real-time embedded software. The controls group established also a very close collaboration with the GSI laboratory in Germany. In this context, a new version of the FESA product (V3.0) was developed with the objective to make it exportable to other Physics laboratories.

## **BE-ASR [Group](#)**

The Administration, Safety and Resources (ASR) group is mandated to provide overall assistance to the department, to each individual group and to each and every member of the personnel in the department in the smoothest and most unobtrusive way while being careful at the same time to minimize the inevitable overhead associated with administrative work, resources planning and control, and Safety.

In 2010 the group has finished the integration and restructuring of activities and tasks started the year before.

### **Administration & Secretariats – BE-ASR-AS**

The Administration and Secretariats team is tasked with ensuring an effective and high quality administrative assistance for Group Leaders and Section Leaders, as well as providing an administrative support for all categories of personnel for a wide range of activities. The team of six group secretaries and three assistants in the Central Secretariat is split between the Meyrin and Prévessin parts of the CERN site and located in different buildings.

In 2010, the team in the central secretariat was partly renewed with one departure and one arrival. Another secretary was hired and attached to the OP group. She shares her time between the MedAustron project principally, and the staffing of the secretariat desk at the CCC to a lesser extent.

The recurring activities of the assistants start from the welcoming of new arrivals, ensuring that appropriate space and furniture is made available, as well as the management and follow-up of contract extensions, transfers, detachments, contract terminations and departure formalities. Of particular importance also is the coordination of Selection committees for Fellows as well as Doctoral, Technical and Summer students. At department level the central secretariat is also involved in the follow-up of induction interviews, mid and end-probation reports, the coordination of MARS exercise as well as all actions related to advancement and promotion of staff members within the Department. In the groups the secretaries assist the CERN personnel with arranging official travel and calculation of reimbursements, treatment of reimbursements of education fees, management of subsistence fees, control of special leaves and sick leaves, third party claims, treatment and monthly control of overtime, shift and stand-by duty.

For the groups and the department the secretaries also provide assistance with the administrative organization of workshops and conferences, the creation and update of group websites and documentation systems and the coordination of visits onsite, and most importantly for us in the CCC.

The application of the new contract policy (Administrative Circular No. 2, revised) which was introduced in 2009 has also created a certain number of new administrative actions: at the level of each Group, the determination of the needs, drafting of vacancy notices, drawing up of long and short candidates' lists, etc. have all required considerable administrative support. At Department level, the editing of reference documents, as well as the publication and follow-up of 23 vacancy notices also required care and diligence by the Administration & Secretariats section.

### **Resources & Logistics – BE-ASR-RL**

In 2010 the section continued with the integration of the three activities added to our mandate in 2009, namely space management, training, as well as administrative and budget monitoring of the EU-cofunded activities in the Department. The team was partly renewed with one departure on retirement and one arrival as a replacement. In parallel the workload of the team for the assistance to the DPO has been increased which has been made possible through a rationalisation of resources for other tasks.

The first activity of the section covers **financial and budget related activities** in three different domains:

- Monitoring and follow-up of the invoices received by the Department,

- Assistance to the DPO for the control and monitoring of data entry, as well as the overall management of budget codes and signature rights in EDH.
- Administrative follow-up of EU co-funded activities in the Department, and of collaborations with outside laboratories and institutions, through the creation of new budget codes, support to the management to establish and implement the staff plan, as well as control and monitoring of the personnel and material expenditure in order to ensure consistency towards the overall resources forecast of EU co-funded activities.

Special effort for **space management** continued in 2010, in particular for the centralization of the planning and management of the works in the department's offices, labs and workshops. Concerning relocations and space optimization, beyond the normal flux of a large department, the following are worth mentioning: complete relocation of MedAustron and CNAO personnel in Building 37; creation of two new meeting rooms in Building 6; negotiation and start of the necessary works to relocate the technical facilities of the ADAM Project in Building 2250 at LHC Point 2; start of the works to create new conventional and radioactive workshops and storage space for BE-BI in Building 283. Active collaboration in the "Groupe de Travail sur le Partage de l'Espace" (GTPE) and "GTPE for Works" has made this possible with minimum disruption. The situation of available office space, as well as space for workshops and laboratories, remains however critical and requires careful management.

The section is also responsible for the overall **logistics** of the department, which includes the management of keys and cylinders, the inventory of valuable equipment, the monitoring and control of the use and expenditures for fixed and mobile telephones, management of photocopiers and of the office and workshop furniture. Beyond the usual monitoring of invoices and payment for the vehicles of the department, the list of rented vehicles has been updated, with a view to a possible reduction of the car pool, and the long-distance car booking system was restructured and updated. The section has also facilitated the introduction of a car-sharing scheme provided by an external rental car company.

Finally, the section is responsible for the overall management of **training** given to personnel in the department. In 2010 a proposal for a new working method for providing language courses has been presented and accepted, and will be implemented in 2012 within the Department. The section leader is a member of the Training Executive Committee (TEC), a member of the TEC working group for language courses, and chairperson of the TEC working group on training statistics. In 2010, this last working group, together with HR-AIS, managed to solve most bugs and implement new tools to facilitate the usage of training statistics.

### **Safety Unit – BE-ASR-SU**

In March 2010, an experienced Safety engineer joined the Safety Unit to take the role of Departmental Safety Officer for the Beams Department. A part time administrative assistant and a fellow working on radiological safety have also joined the Safety Unit, which now comprises six staff and one fellow, plus one open staff post for the recruitment of a nuclear safety engineer.

### **Safety of Personnel**

The new DSO of the Beams Department has gradually become acquainted with the personnel, the various installations and the large range of activities of the department. An effort has been started to improve communication about Safety in the department with regular short email messages, posters and improvement to the [departmental Safety web site](#). Work is also underway to improve the Departmental Safety Plan.

The few accidents to Beams Department personnel, or in the department's premises, were roughly equally split between the categories of "slips, trips and falls", "commuting accidents" and "manual handling". A handful of fires started in Beams Department facilities in 2010, all having an electrical origin; the prevention of electrical fires will have priority in 2011.

The concept of Beam Permit, in use in the PS complex for some time, was extended in recent years to the SPS and LHC. In 2010, a formal procedure for the signature of the beam permits was put into operation, with now over 30 different beam zones directly concerned. Gradually, all beam facilities and zones will be operated with a beam permit, starting with the primary beam experimental areas. This effort is coordinated with the departments and groups concerned and is a crucial step towards quality assurance in the operation of CERN's beam facilities.

The LHC has overriding priority for the Safety Coordination team, but some other major projects and workplaces have required particular scrutiny this year. Of particular relevance to the Beams Department are the dismantling of the old West Area Neutrino Facility (WANF) and the installation of HiRadMat in its place, and the installation of Linac4. A particular effort has been made by Safety Coordinators to be present in projects at an earlier stage, when design and integration are discussed. This was the case in 2010 for the integration of the measures decided by the Radiation to Electronics (R2E) working group, and the design changes for the collimation section at Point 3 of LHC. The benefits are visible and this effort will be pursued.

Work planning and procedures for work to be done in controlled areas should be reviewed with radiological risks in mind; hence Safety Coordinators and the Radiation Protection group have simplified the procedures and documents such that the team that will actually perform the work can provide most of the information in a single and simple document that makes life easier for all parties: the working team, Safety Coordination, the Radiation Safety Officer and Radiation Protection. When the radiological risks during an intervention are high, the DIMR document is completed together with the Radiation Safety Officer, and an ALARA committee is convened to study the planned intervention and discuss the procedure and alternatives.

The Laser Safety Officer of the Beams Department maintains the inventory of all dangerous lasers in the Accelerator and Technology sector, and in the HSE unit, and four new installations have been referenced and inspected. The introduction of a new EU Directive on artificial optical radiation at large has forced a delay on the writing of the Safety Instruction on optical fibers. A document with a wider scope is now in preparation.

### **Safety of Installations**

A new Tripartite Agreement has been signed in 2010 between CERN and the Host States agencies that oversee nuclear facilities in their countries. The intent of this Tripartite Convention is that safety should be appropriately ensured at CERN at a level commensurate with that required in the Host States for similar installations. This convention calls for new methods and procedures to be deployed at CERN and work has started to structure the underlying documentation.

Quality assurance in matters of safety is also mandated by this new convention and is high on our list of topics to be addressed. In particular the maintenance and intervention procedures on equipment that are particularly important for safety (EIS), or related to safety, should be performed with particular care following an appropriate quality assurance plan. The Safety Unit promotes quality assurance in matters related to safety within the equipment groups concerned, explaining and describing the needs and the importance of quality assurance in this context.

---\*\*\*---