

DIRAC Note 08-03
29 February 2008

Installation of C_4F_{10} Cherenkov detectors

V. Brekovskikh, A. Kuptsov

GENEVA
2008

In 2006 the DIRAC setup was upgraded (fig. 1). Downstream of the spectrometer magnet the new detectors were installed: vertical and horizontal scintillation hodoscopes, aerogel and C_4F_{10} Cherenkov detectors and preshowers. The downstream detectors and supports before installation of the aerogel and C_4F_{10} detectors are in fig. 2. These detectors are drift chambers, vertical and horizontal scintillation hodoscopes, N_2 Cherenkov detectors, preshowers and muon scintillation hodoscopes. The downstream detectors and supports after installation of the aerogel and C_4F_{10} detectors are in fig. 3.

Supports downstream of the spectrometer magnet before installation of the aerogel and C_4F_{10} detectors are in figs. 4 and 5. In fig. 5 some parts of the supports are not shown. Existing supports and supports for installation of the aerogel and C_4F_{10} detectors are in fig. 6. New supports for installation of the aerogel and C_4F_{10} detectors are shown in fig. 7 separately.

Support for the aerogel detector is in fig. 8. The support is attached to the platform for the drift chambers and vertical and horizontal hodoscopes. The aerogel detector and support are in fig. 9. The support for C_4F_{10} detectors (bridge) is in fig. 10. The C_4F_{10} detectors and support (bridge) are in fig. 11.

Before installation of the aerogel and C_4F_{10} detectors it was necessary to clear space for them: to cut a part of the radiator box of N_2 detector. Part of the support for C_4F_{10} detectors and temporary supports to cut N_2 detectors are in figs. 12 and 13.

Cutting the N_2 detectors:

1. N_2 detectors in initial position are in fig. 14.
2. N_2 detectors before cutting are in fig. 15. The boxes for N_2 of N_2 detectors are disconnected from the boxes containing spherical mirrors. Gap is 80 mm. The mirrors are protected by sheets of plexiglass.
3. N_2 detectors after cutting are in fig. 16. The boxes for N_2 of N_2 detectors are still disconnected from the boxes containing spherical mirrors.
4. In order to cover the open parts of the boxes for N_2 the profiles and Al sheet were added to the support for safety reason (fig. 17).
5. After that the open parts of the boxes were hermetically closed by steel sheets.
6. N_2 detectors after cutting in the final position are in fig. 18. Plexiglass sheets are removed from the gaps. Boxes for N_2 of N_2 detectors and boxes containing spherical mirrors are connected together.
7. Temporary supports are removed. Profiles and Al sheet are removed and in this place the missing part of the support for C_4F_{10} is installed. Support for aerogel detector is installed (fig. 19).
8. Aerogel and C_4F_{10} detectors are installed (fig. 3).

The authors acknowledge Mauro Giardoni for cutting the N_2 Cherenkov detectors.

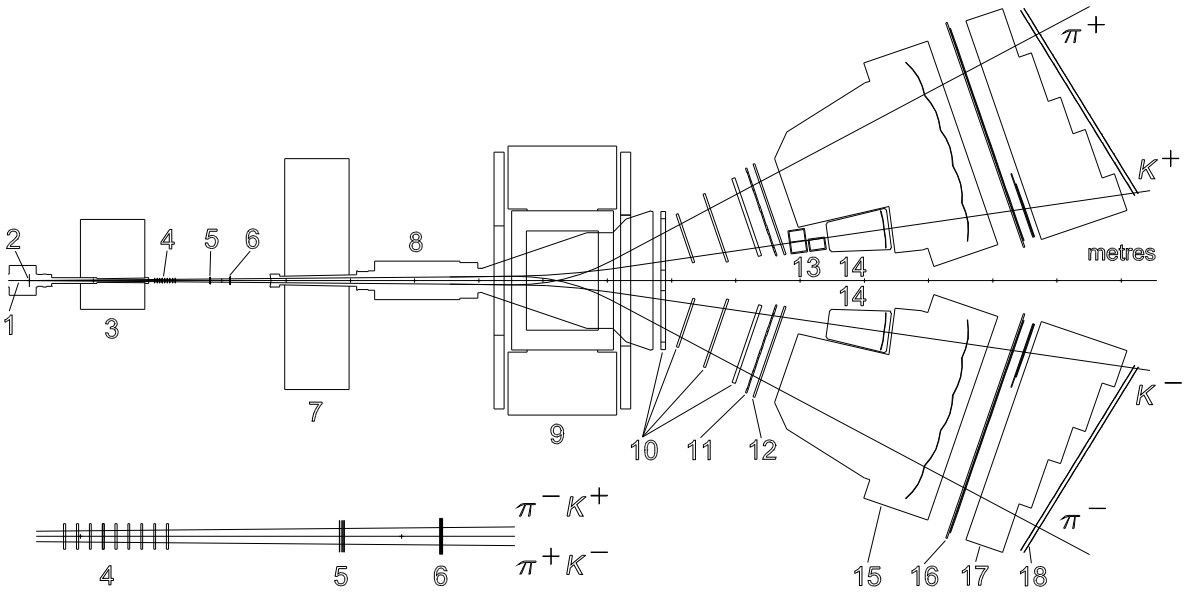

Figure 1: *Scheme of upgraded DIRAC setup (top view). 1 – proton beam, 2 – target, 3 – shield, 4 – microdrift chambers, 5 – scintillation fiber detector, 6 – ionization hodoscope, 7 – shield, 8 – vacuum, 9 – spectrometer magnet, 10 – drift chambers, 11 – vertical scintillation hodoscopes, 12 – horizontal scintillation hodoscopes, 13 – aerogel Cherenkov detectors, 14 – C_4F_{10} Cherenkov detectors, 15 – N_2 Cherenkov detectors, 16 – preshowers, 17 – absorbers, 18 – muon scintillation hodoscopes. π^+ , π^- , K^+ , K^- – trajectories of pions and kaons from $\pi^\pm K^\mp$ atom breakup.*

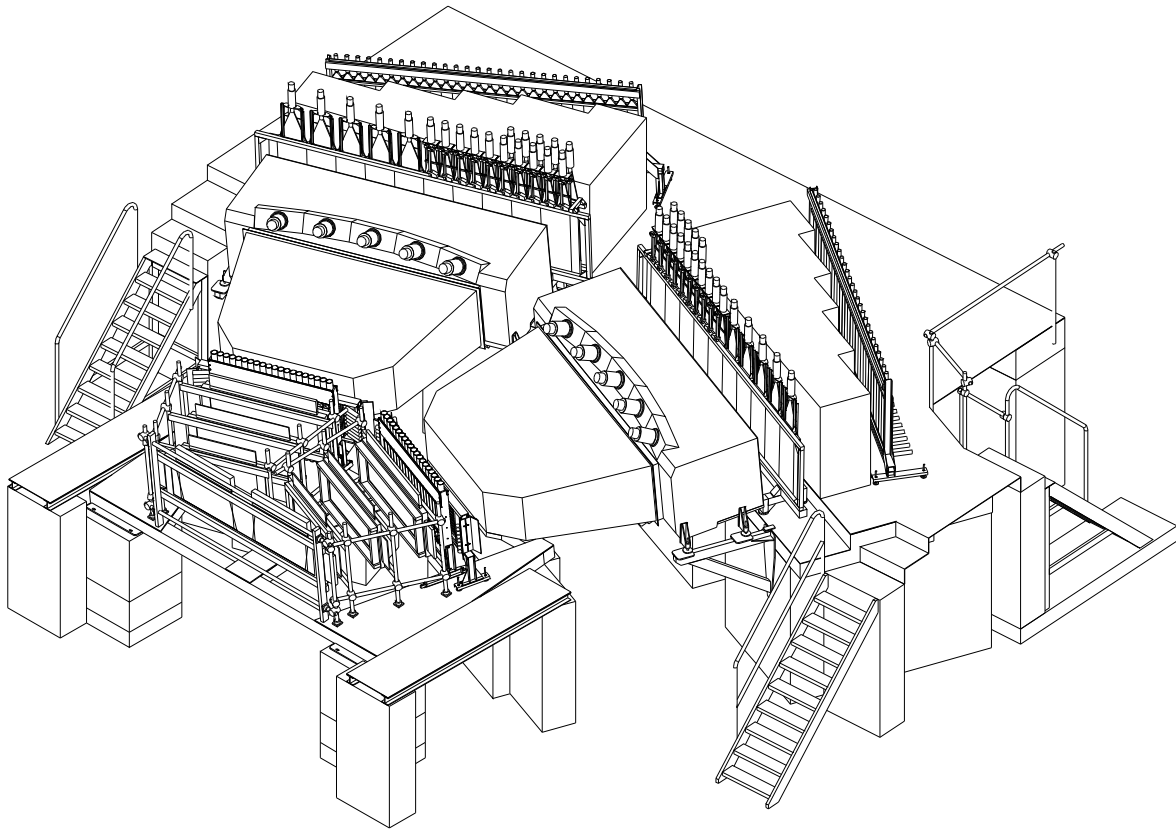

Figure 2: *Detectors and supports downstream of the spectrometer magnet before installation of the aerogel and C_4F_{10} detectors.*

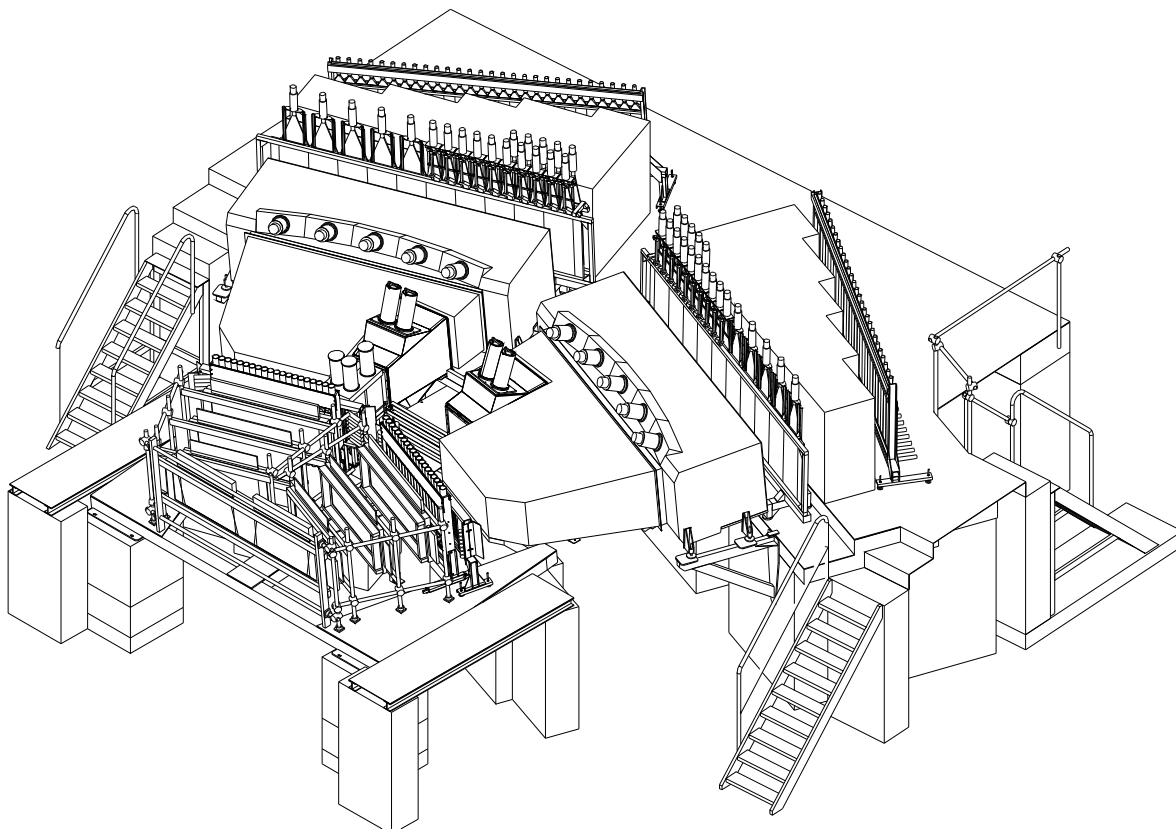

Figure 3: *Detectors and supports downstream of the spectrometer magnet after installation of the aerogel and C_4F_{10} detectors.*

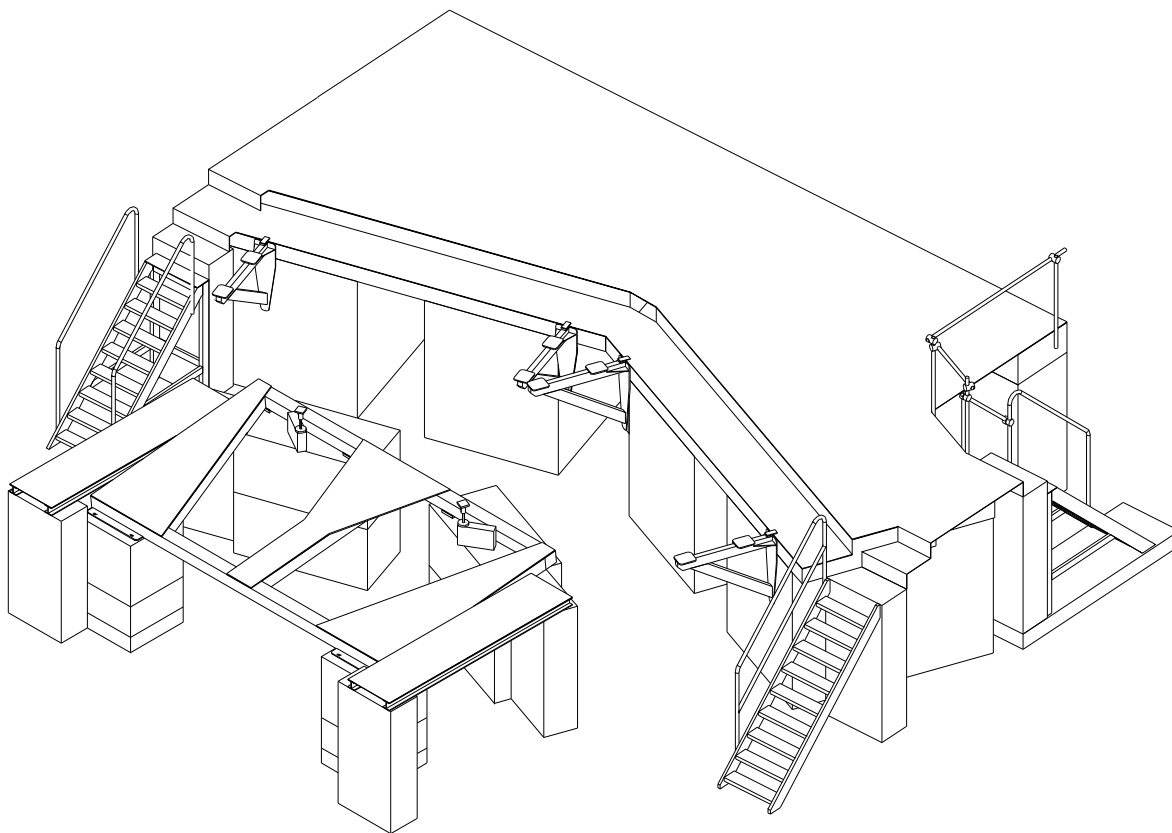

Figure 4: *Supports downstream of the spectrometer magnet before installation of the aerogel and C_4F_{10} detectors.*

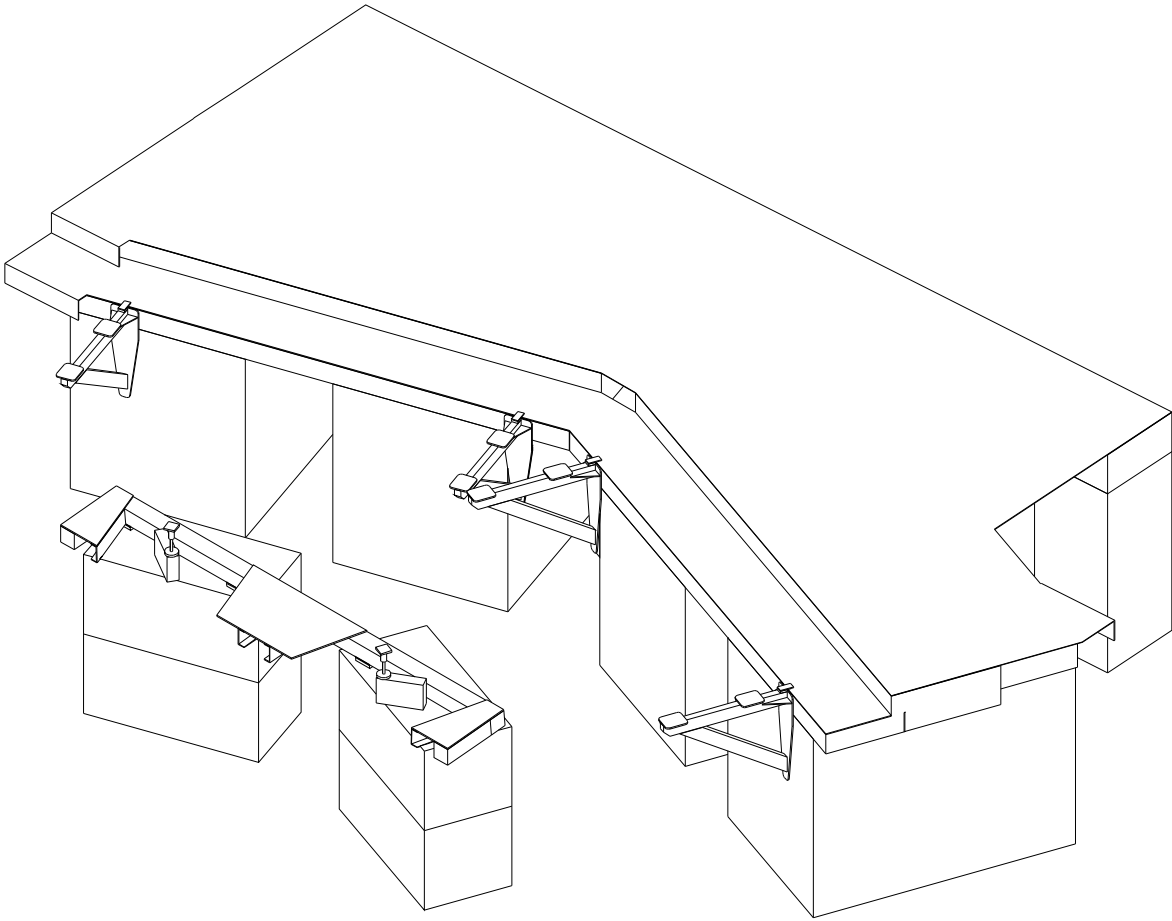

Figure 5: *Supports downstream of the spectrometer magnet before installation of the aerogel and C_4F_{10} detectors. Some parts of the supports are not shown.*

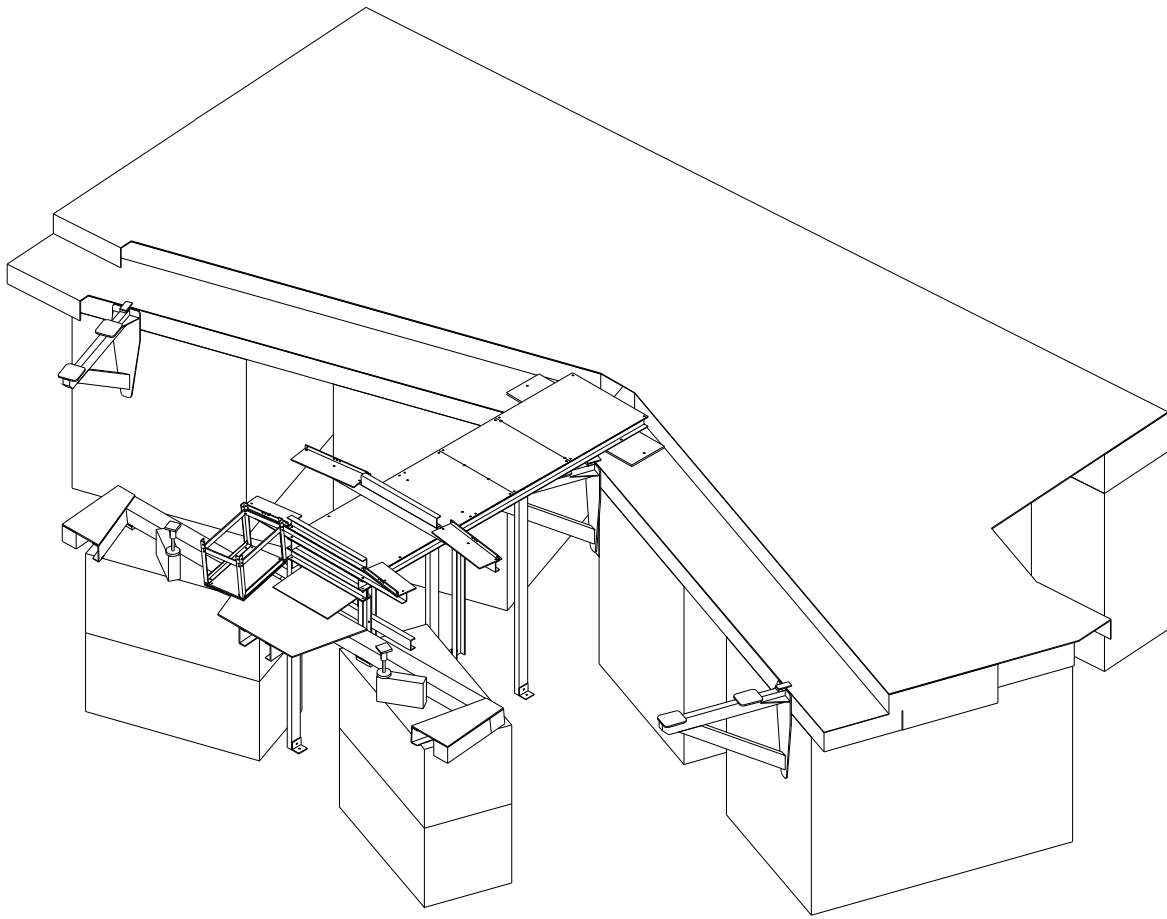

Figure 6: *Existing supports and new supports for installation of the aerogel and C_4F_{10} detectors.*

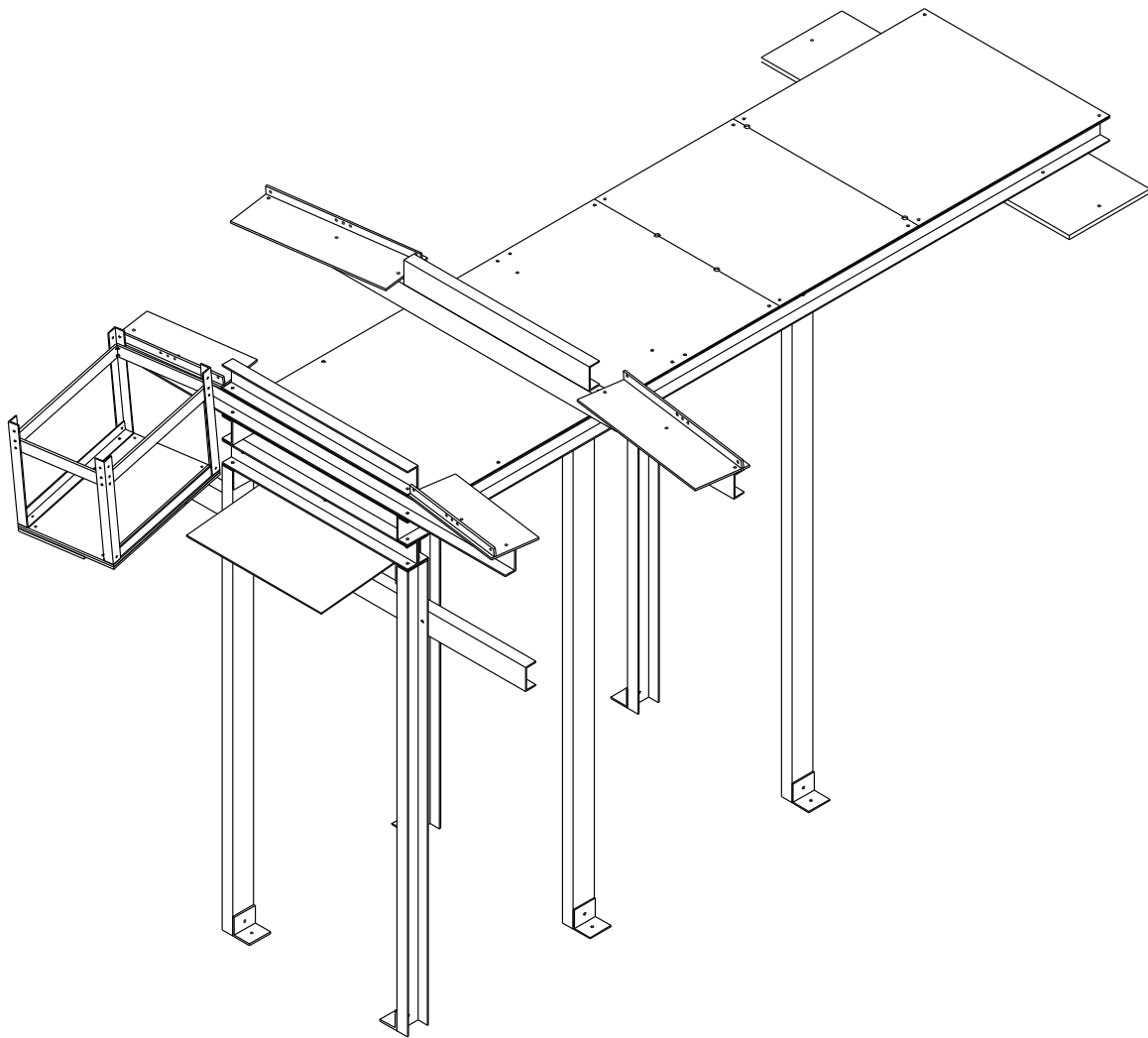

Figure 7: *New supports for installation of the aerogel and C_4F_{10} detectors.*

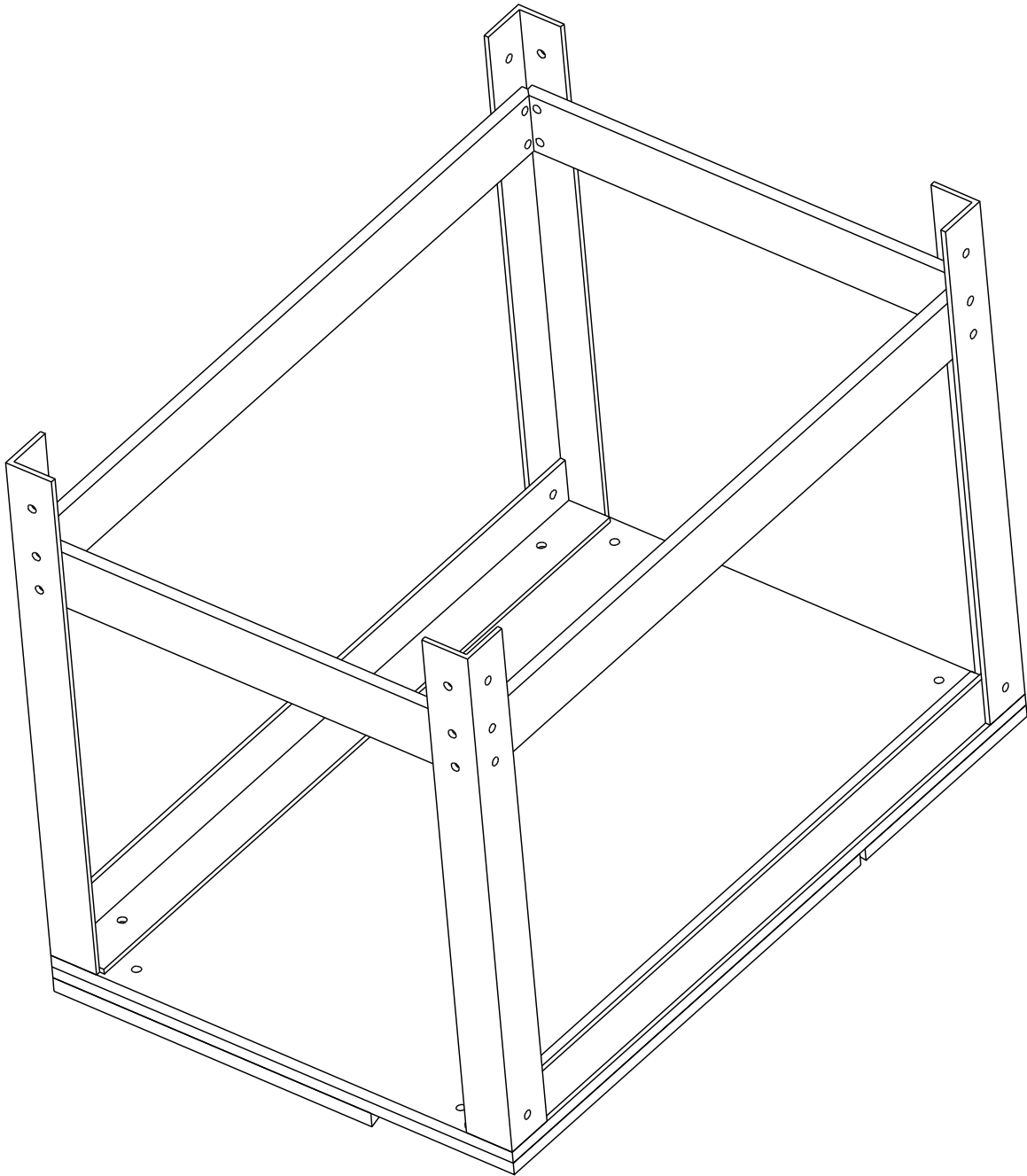

Figure 8: *Support for the aerogel detector.*

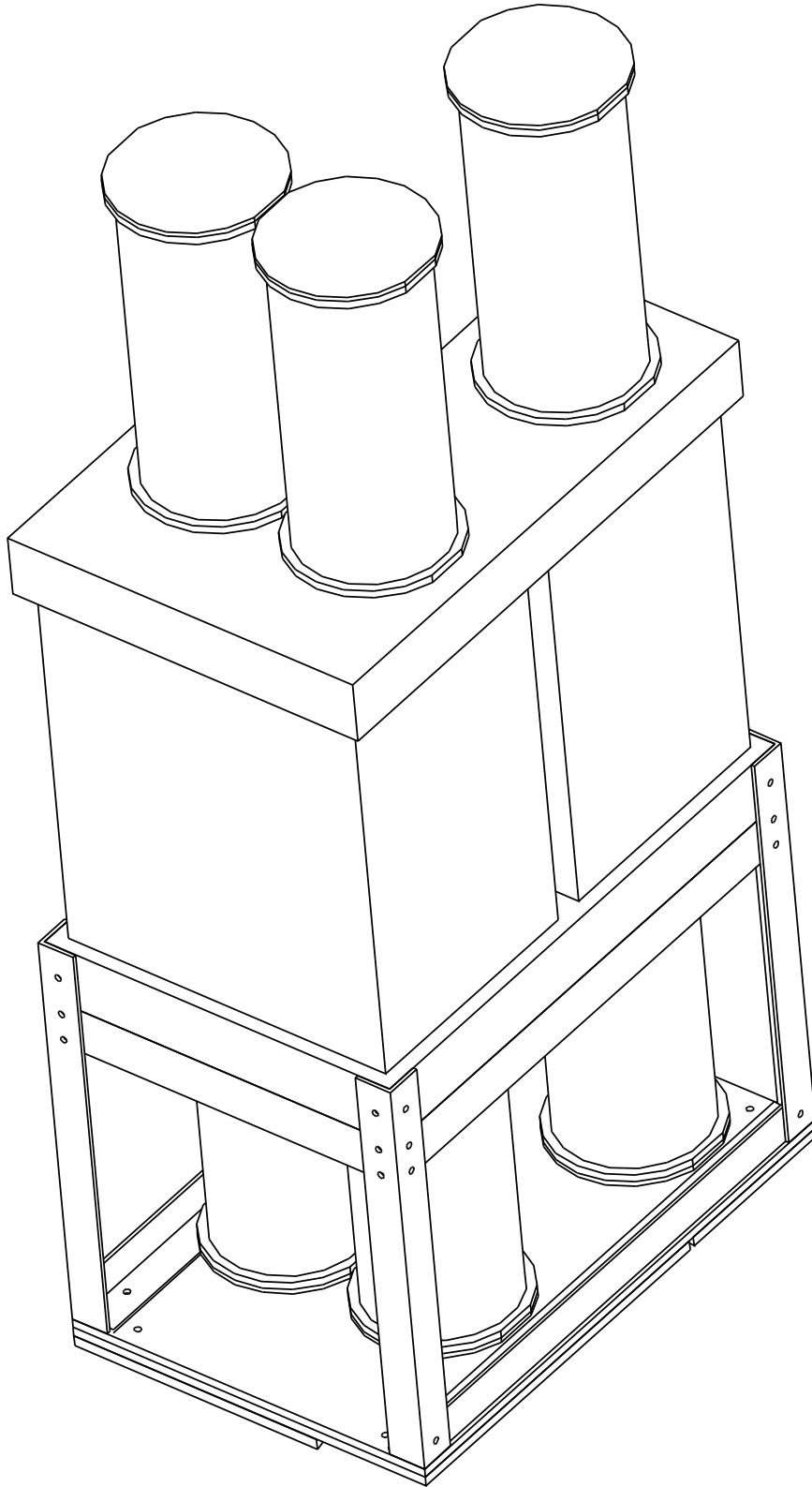

Figure 9: *Aerogel detector and support.*

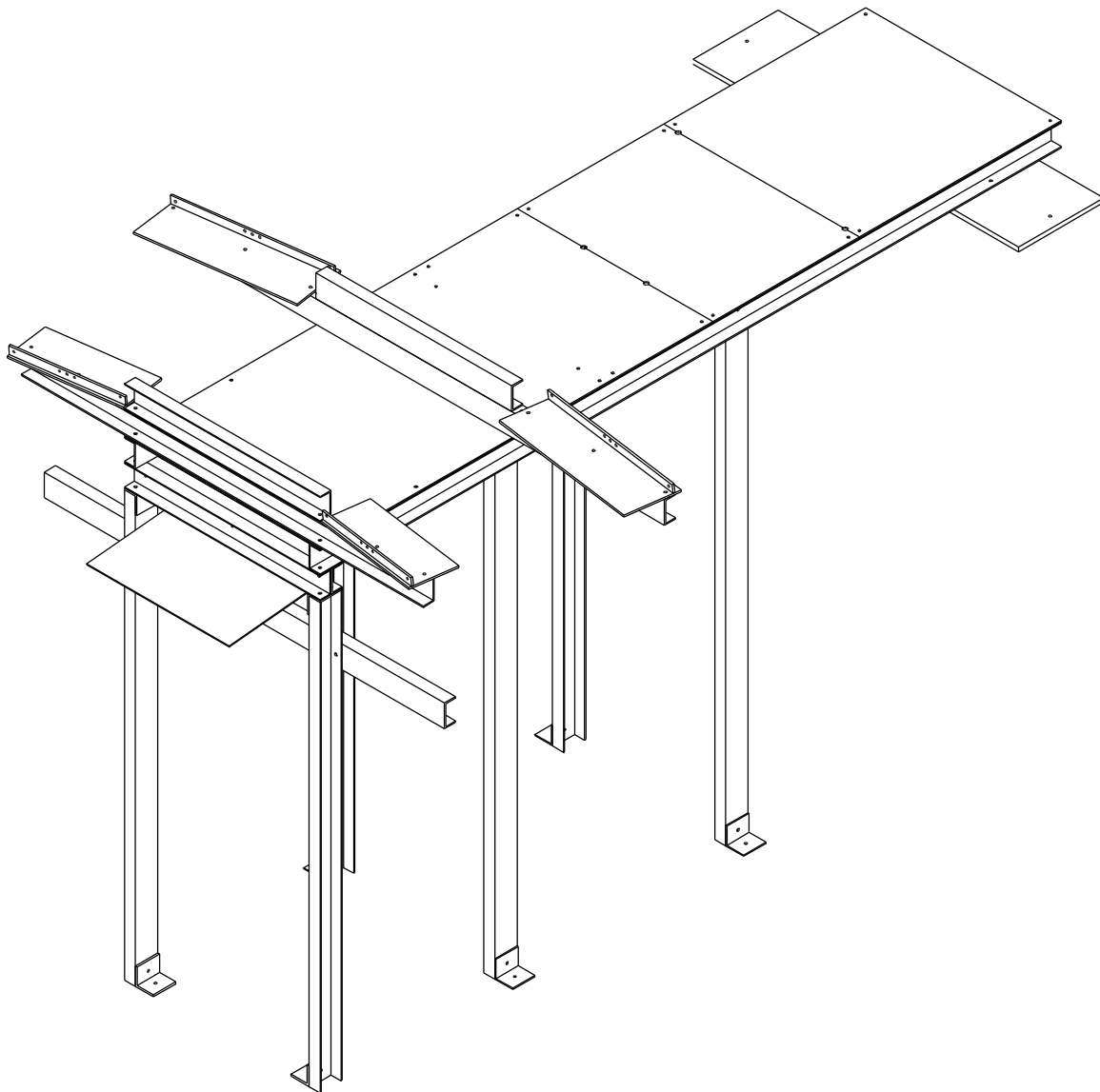

Figure 10: *Support for C_4F_{10} detectors (bridge).*

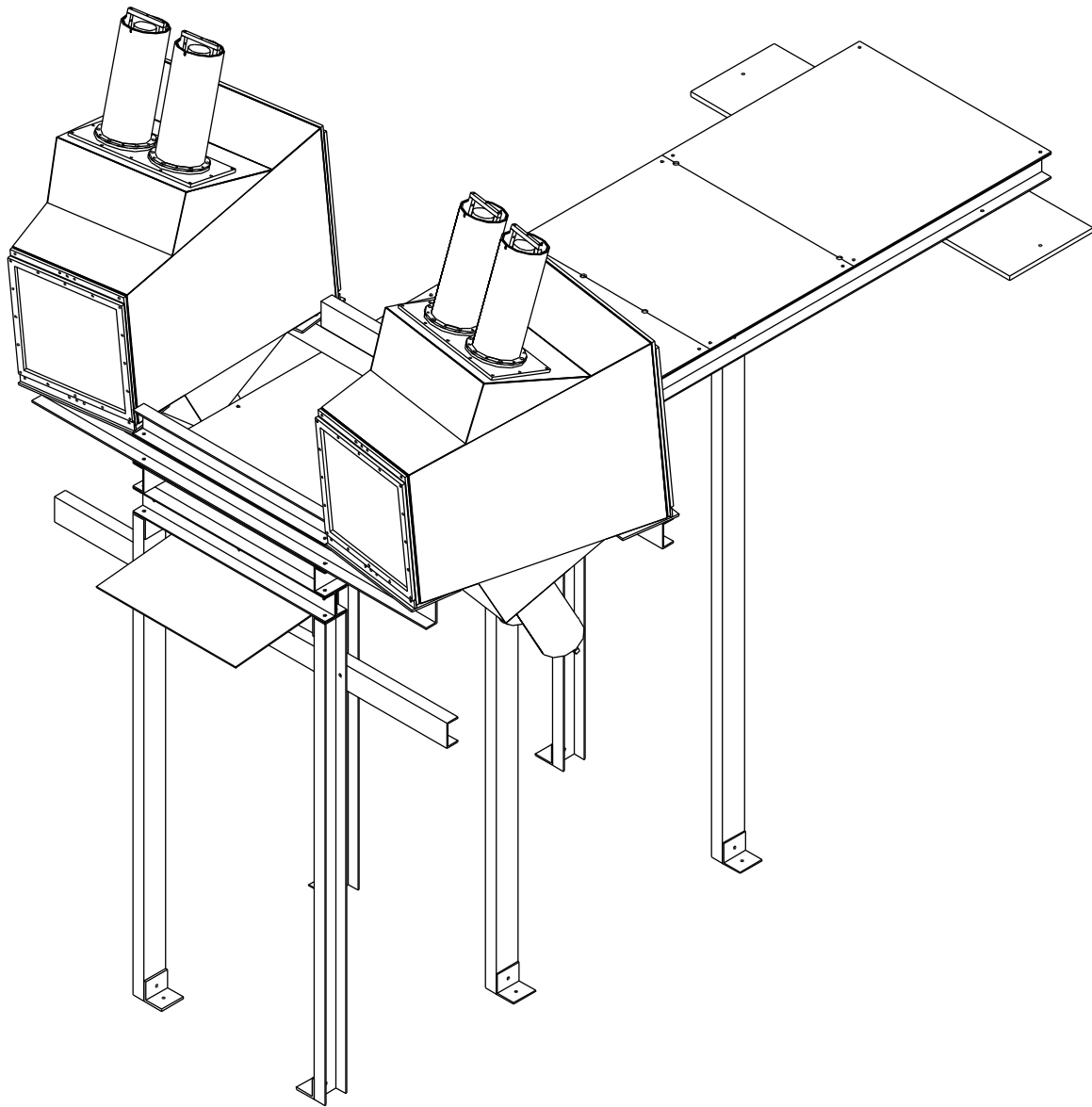

Figure 11: C_4F_{10} detectors and support (bridge).

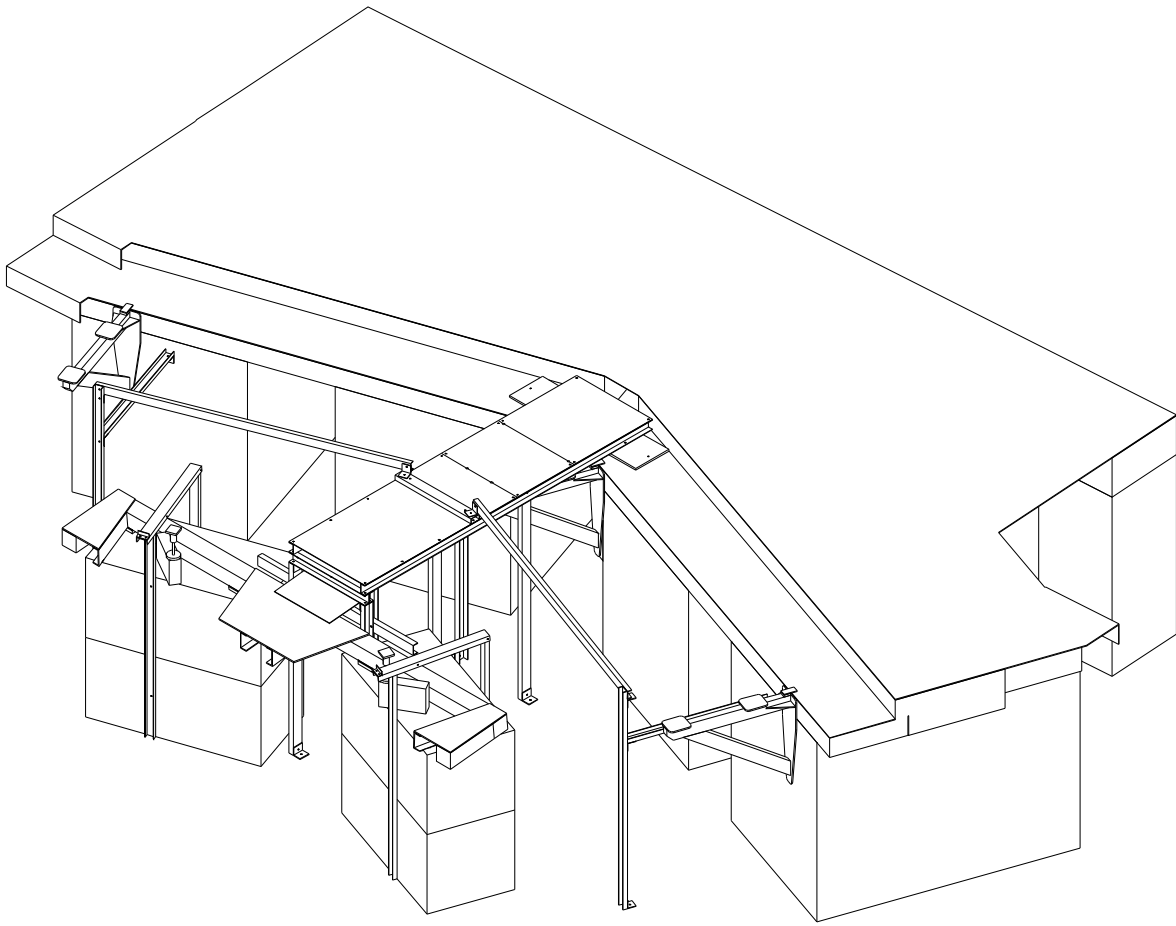

Figure 12: *Part of the support for C_4F_{10} detectors and temporary supports to cut N_2 detectors.*

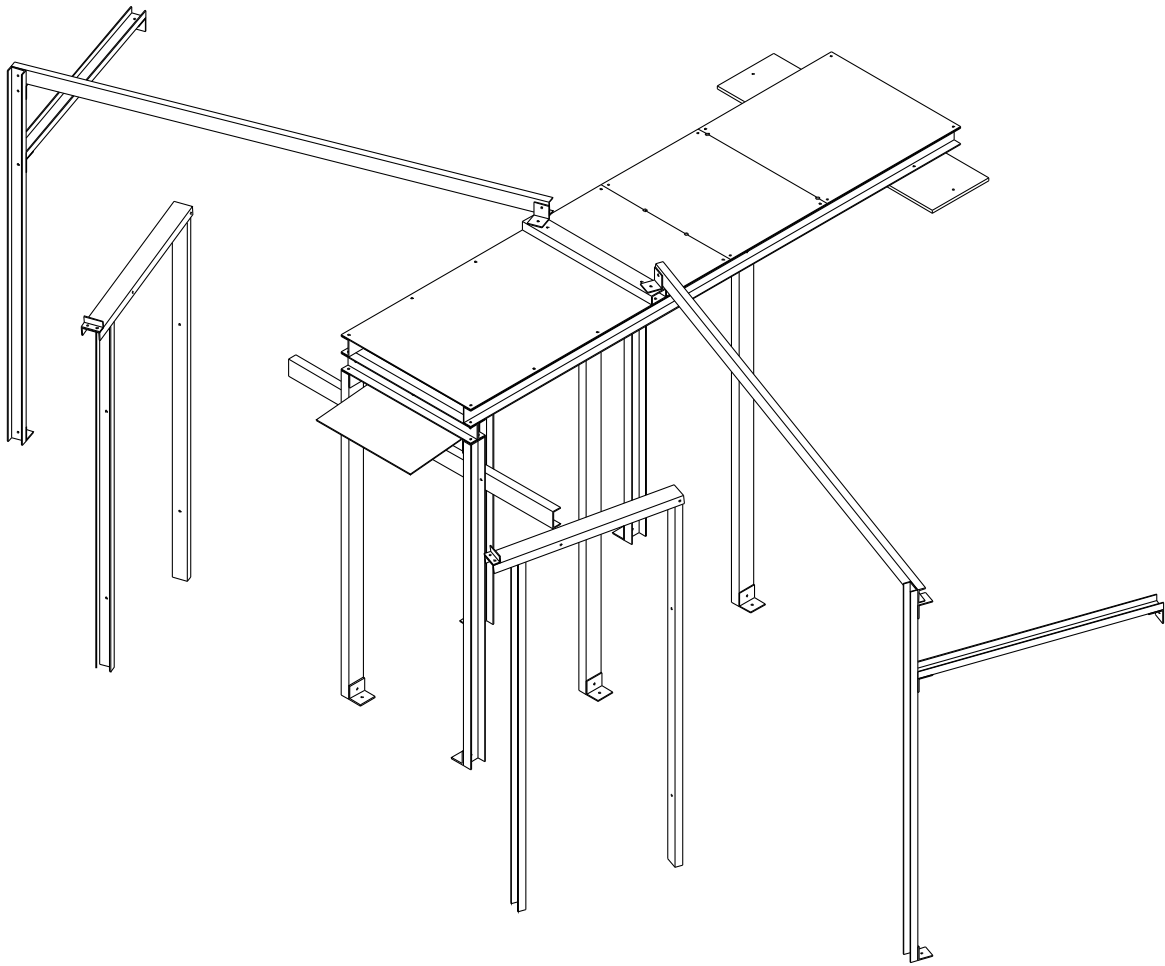

Figure 13: *Part of the support for C_4F_{10} detectors and temporary supports to cut N_2 detectors.*

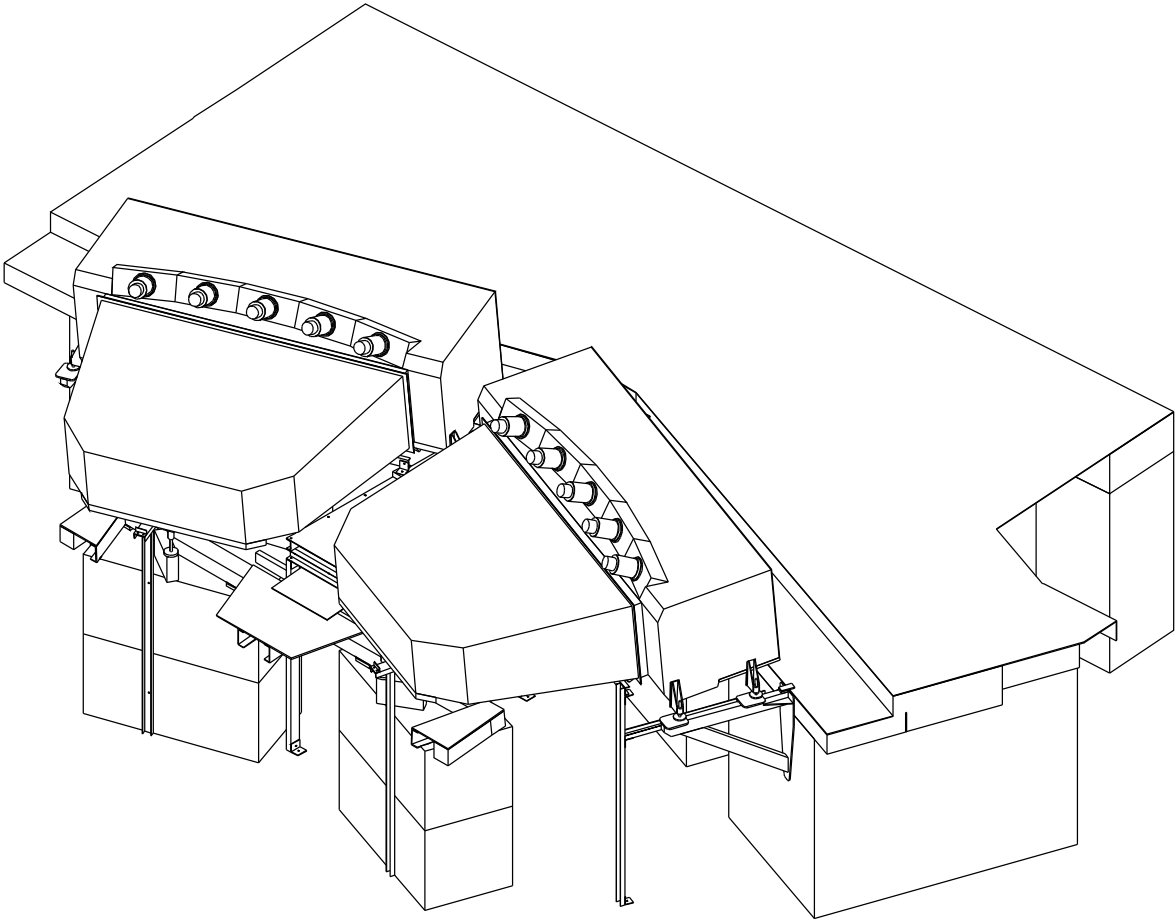

Figure 14: N_2 detectors before cut. Initial position.

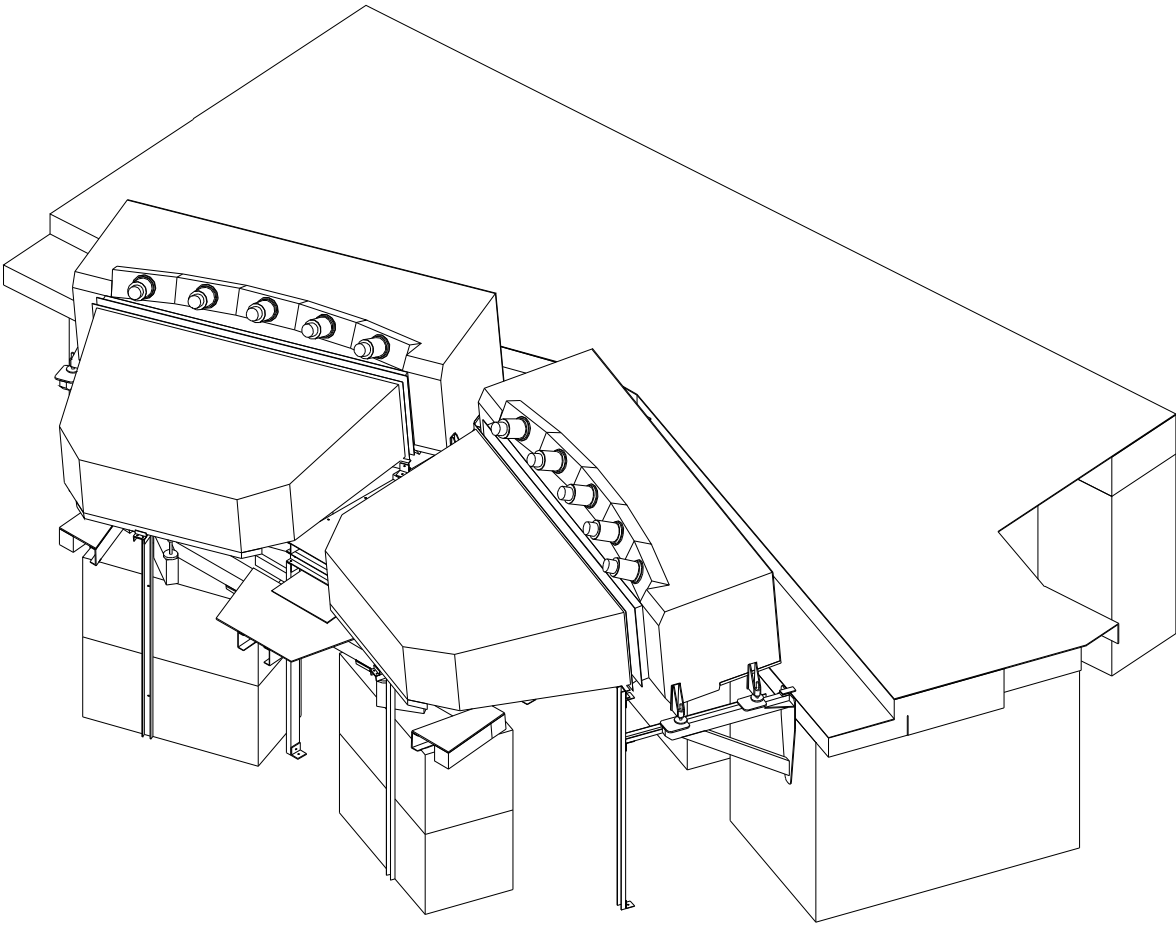

Figure 15: N_2 detectors before cut. Boxes for N_2 of N_2 detectors are disconnected from boxes containing spherical mirrors. Gap is 80 mm.

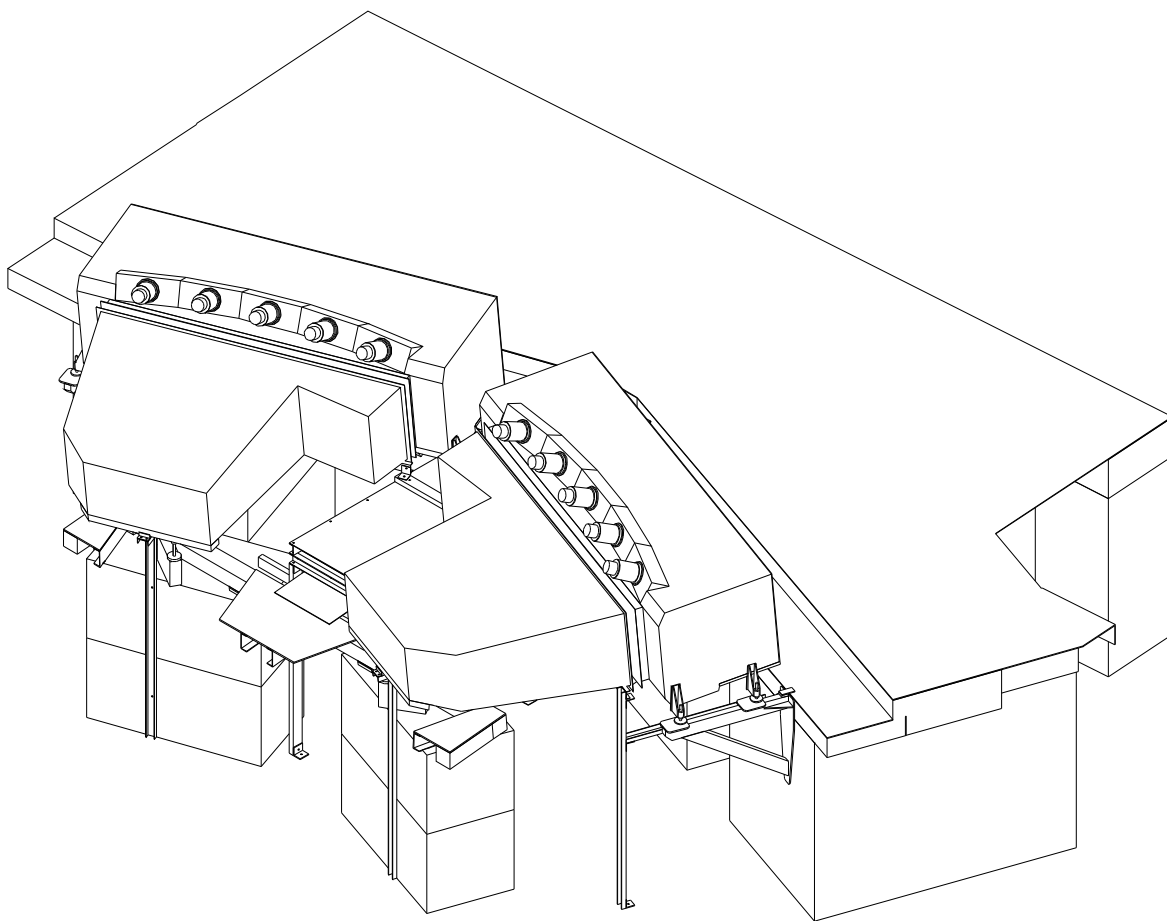

Figure 16: N_2 detectors after cut. Boxes for N_2 of N_2 detectors are still disconnected from boxes containing spherical mirrors. Gap is 80 mm.

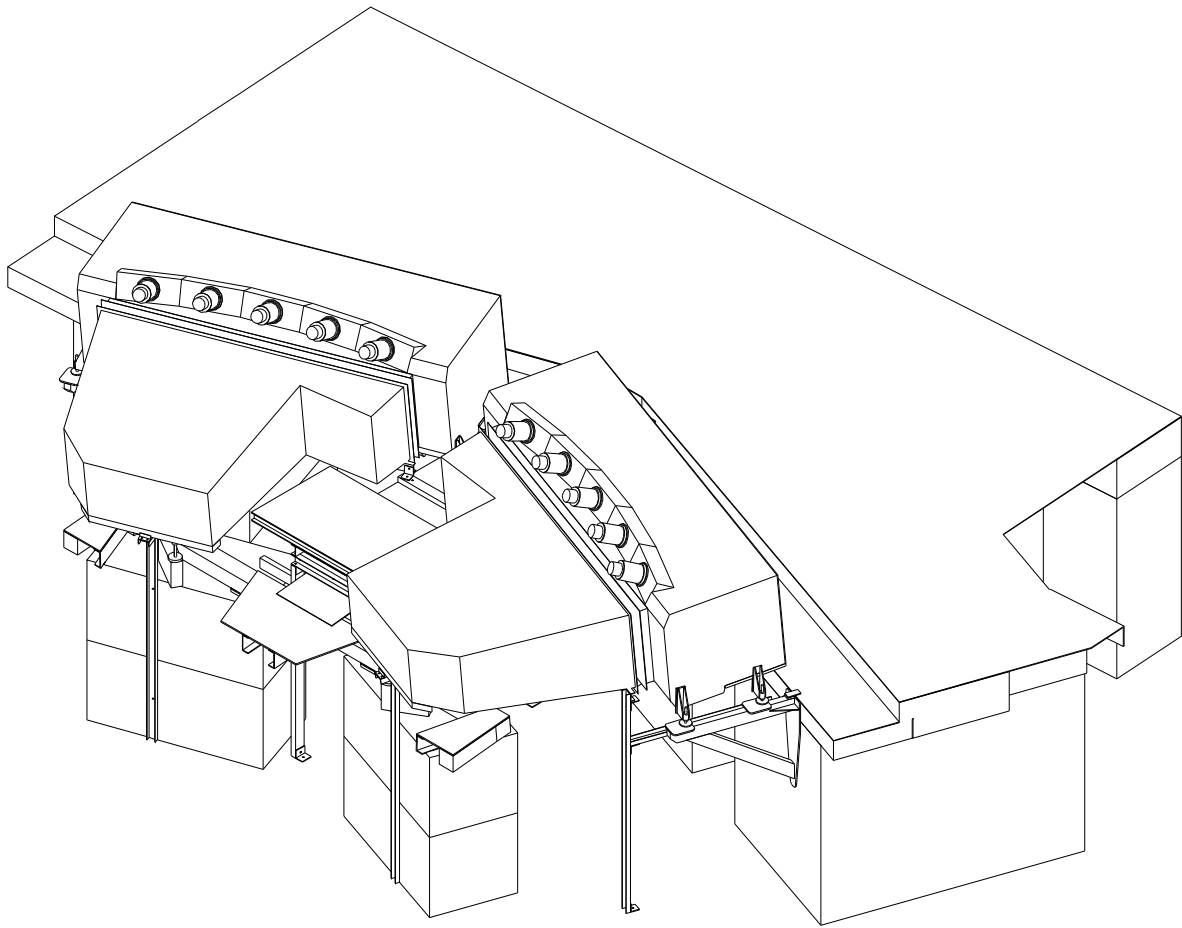

Figure 17: N_2 detectors after cut. Profiles and Al sheet are added to the support for safety reason. After that the open parts were hermetically closed by steel sheets.

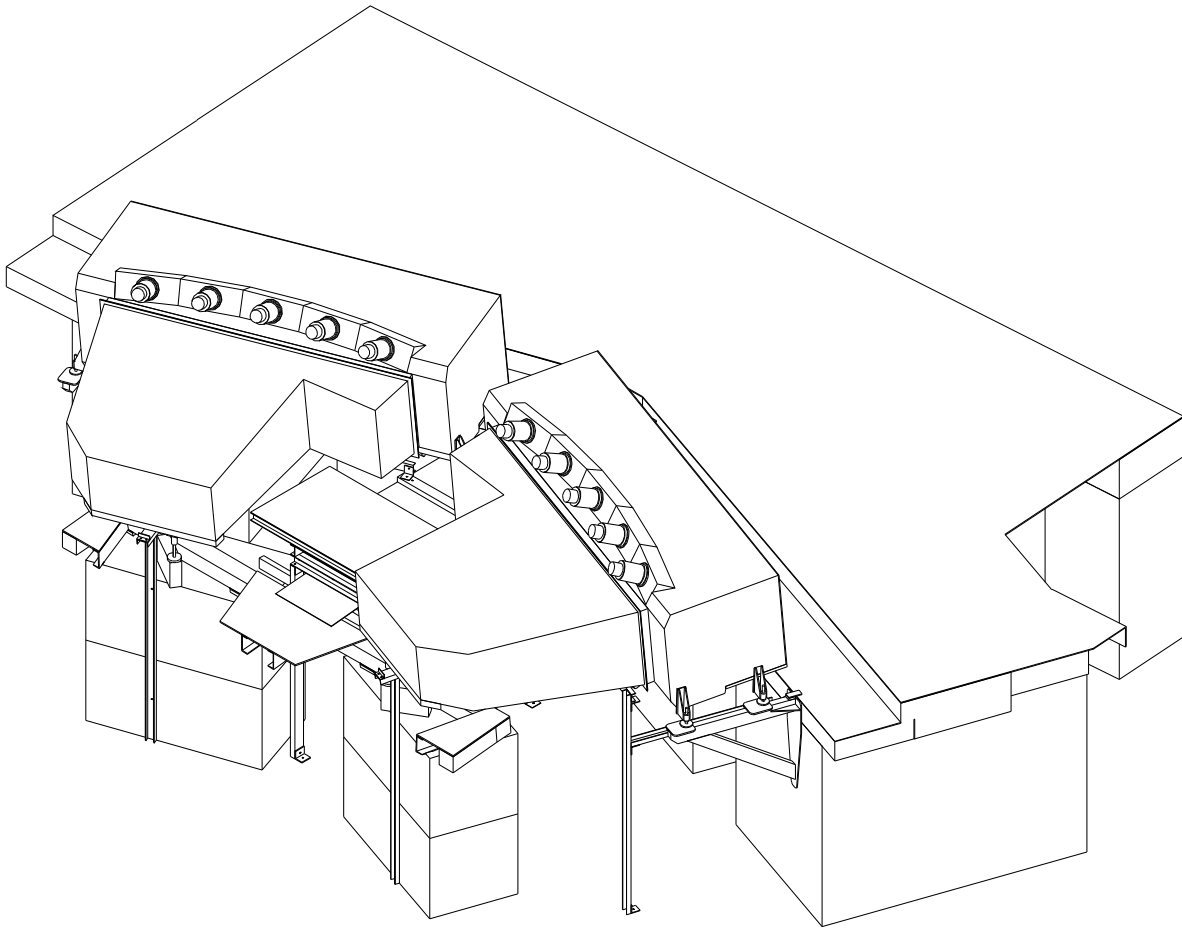

Figure 18: N_2 detectors after cut in final position. The plexiglass sheets are removed from the gaps. Boxes for N_2 of N_2 detectors and boxes containing spherical mirrors are connected together.

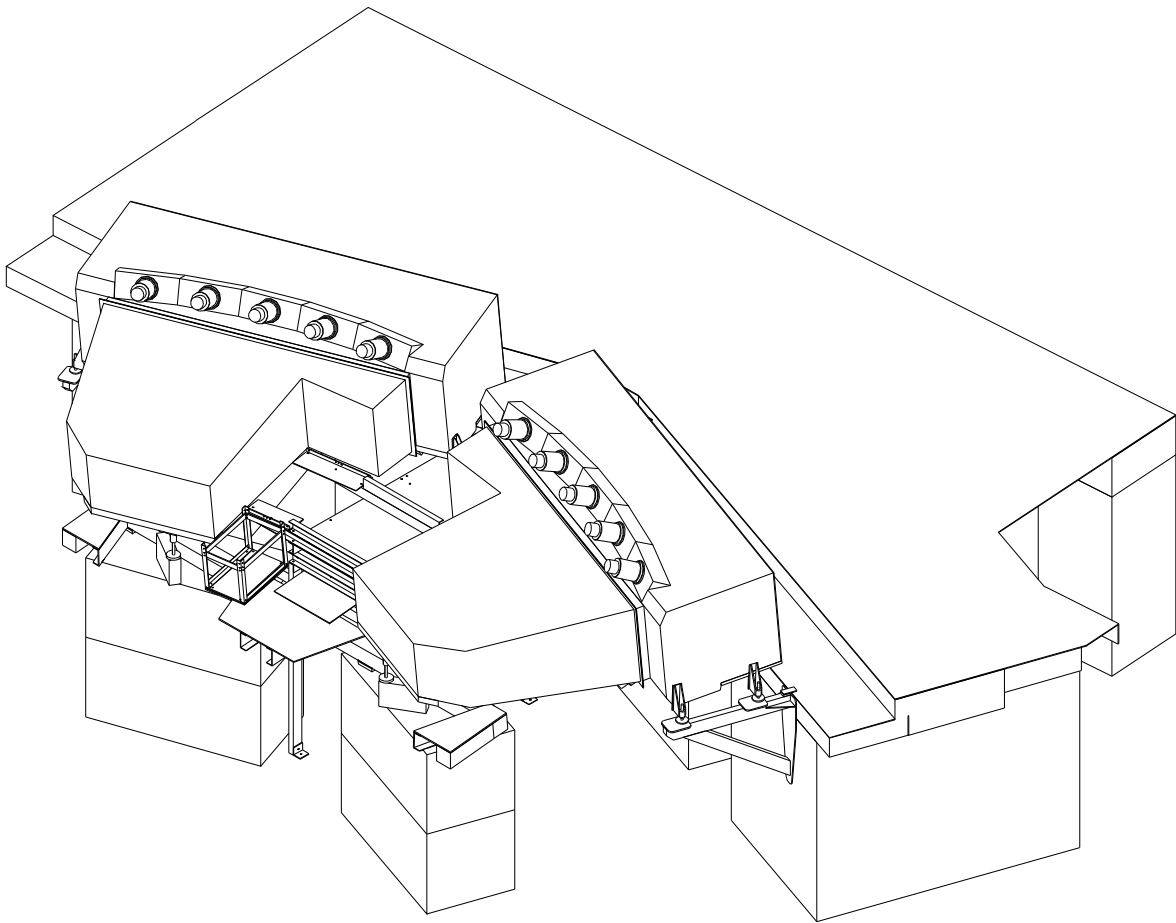

Figure 19: N_2 detectors after cut in final position. Temporary supports are removed. Profiles and Al sheet are removed and in this place the missing part of the support for C_4F_{10} is installed. Support for aerogel detector is installed.