



EURISOL DS Project

Task 8: SC cavity development

Deliverable D5

Preparation of test bench for coupler conditioning

E. Rampnoux, S. Bousson, G. Olry, P. Duthil, C. Joly, J. Lesrel,
CNRS/IN2P3/IPN Orsay (France).

A. Facco, F. Scarpa, INFN-Laboratori Nazionali di Legnaro, Padova,
(Italy).

Planned Date (month): 22

Achieved Date (month): 51

Lead Contractor(s): CNRS/IN2P3

RIDS 515768 TASK: 8	DATE:	
DELIVERABLE: D5	PAGE - 1 -	

A 352 MHz capacitive power coupler has been developed for the 2-gap spoke cavities to be mounted on the 56mm diameter port. The same coupler is also suitable for the 352 MHz Half-Wave resonator, providing that a specific RF transition is used to manage the differences in the cavity power coupler port diameter difference.

To condition the couplers, a test bench was conceived and constructed at IPN Orsay in order to perform the RF conditioning of two couplers at the same time in the travelling wave mode (Fig.1). For this, a coupling cavity was designed (Fig. 2)

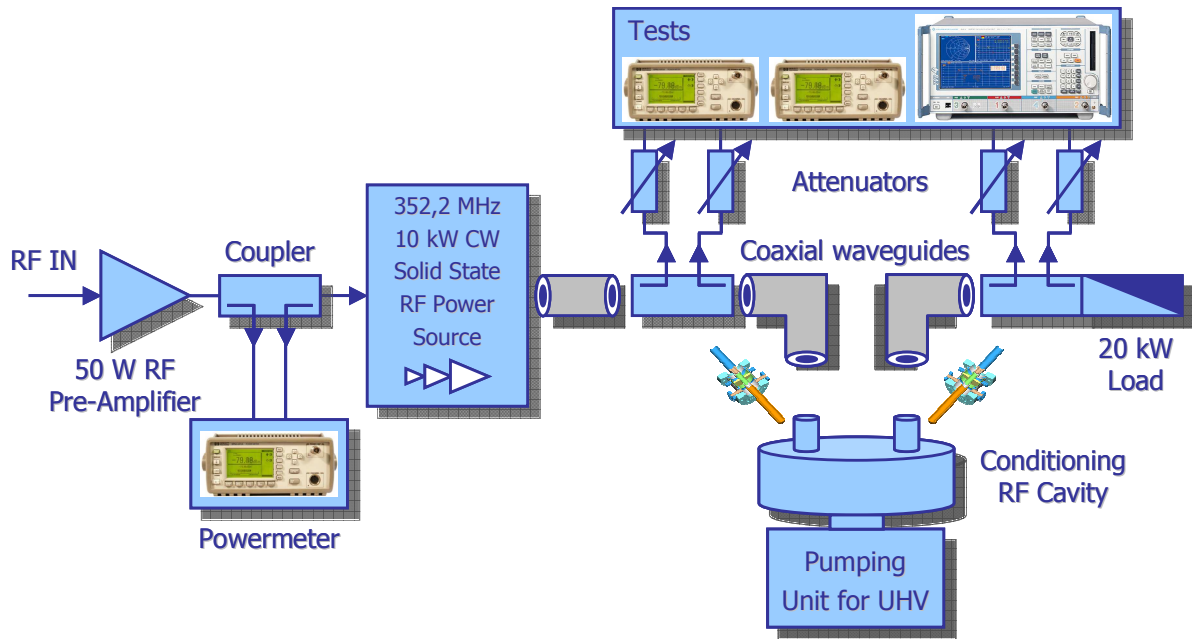

Figure 1: Schematic of the 352 MHz power coupler conditioning test stand.

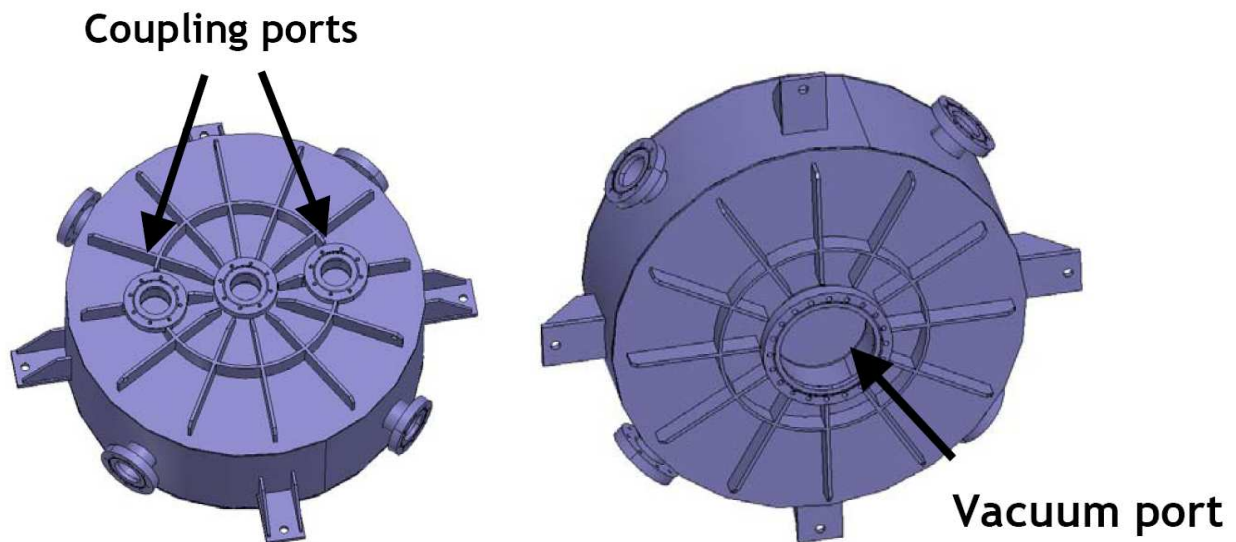

Figure 2: Drawings of the both side of the conditioning bench coupling cavity. It allows the RF power transition from one coupler to another and has ports for vacuum pumping and frequency tuners.

After reception of the two complete power coupler prototypes, the assembly of the

RIDS 515768	TASK: 8	DATE:	EURISOL Design Study
DELIVERABLE:	D5	PAGE 2	

conditioning test bench has been achieved after at careful cleaning and final assembly (Fig. 3 and 4) of the important parts (RF ceramic windows, coaxial part between the cavity and window, conditioning cavity) in the IPN Orsay clean room

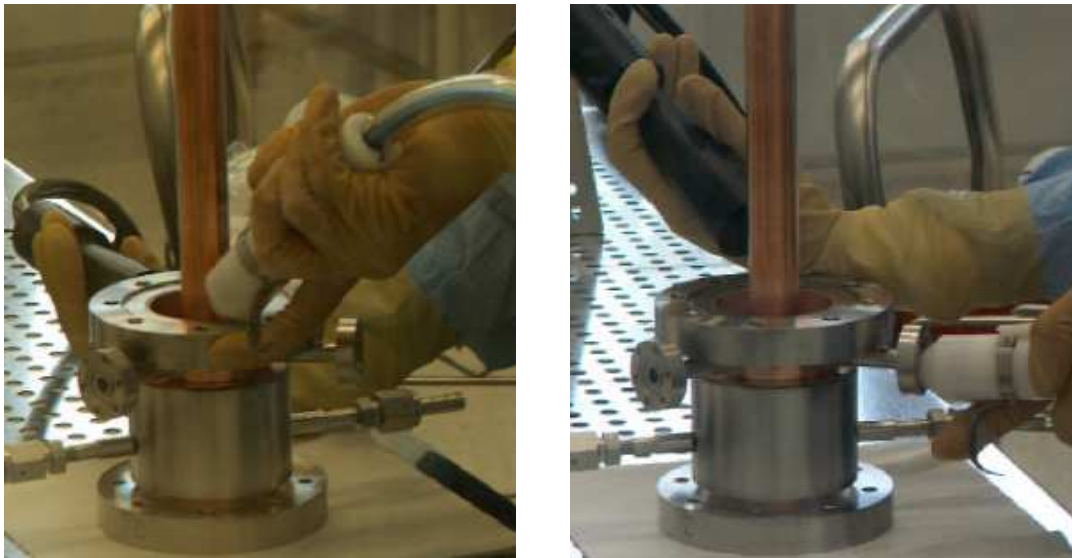

Figure 3: Evaluation of the Power coupler cleaning procedure efficiency by performing a particle counting

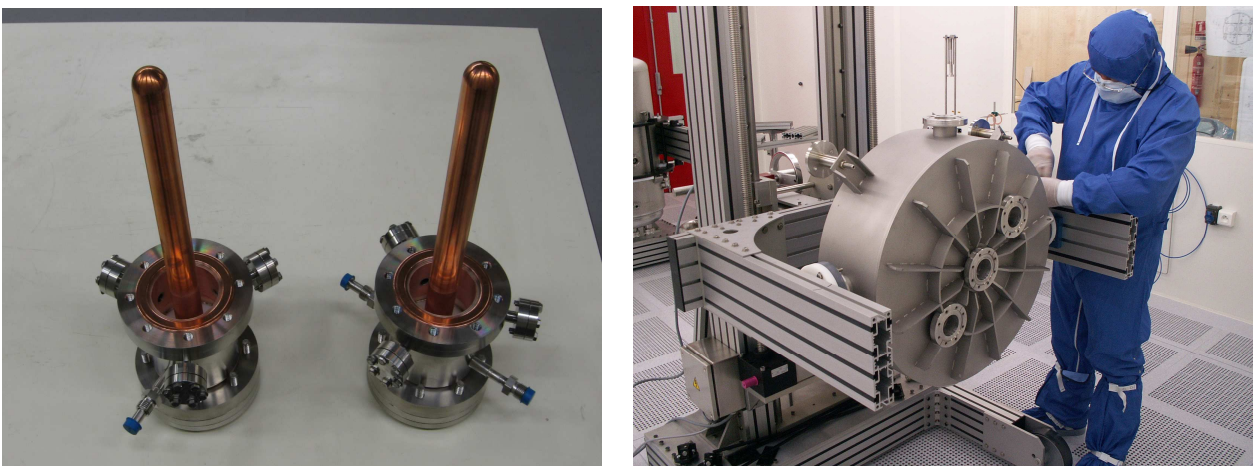



Figure 4: The two power coupler prototypes (left) and the conditioning cavity assembly in the clean room

The conditioning of the power coupler has started on the warm test bench (Fig. 5). This important stage consists in feeding the 2 power couplers mounted in series with an increasing RF power, from 0 to 10 kW, step by step. The aim is to condition the RF surface to get rid of any electron emission or multipacting in the coupler. After a few hours, the couplers succeeded in transmitting the 10 kW of RF power, and a stable operation point was reached.

RIDS 515768	TASK: 8	DATE:	
DELIVERABLE:	D5	PAGE 3	

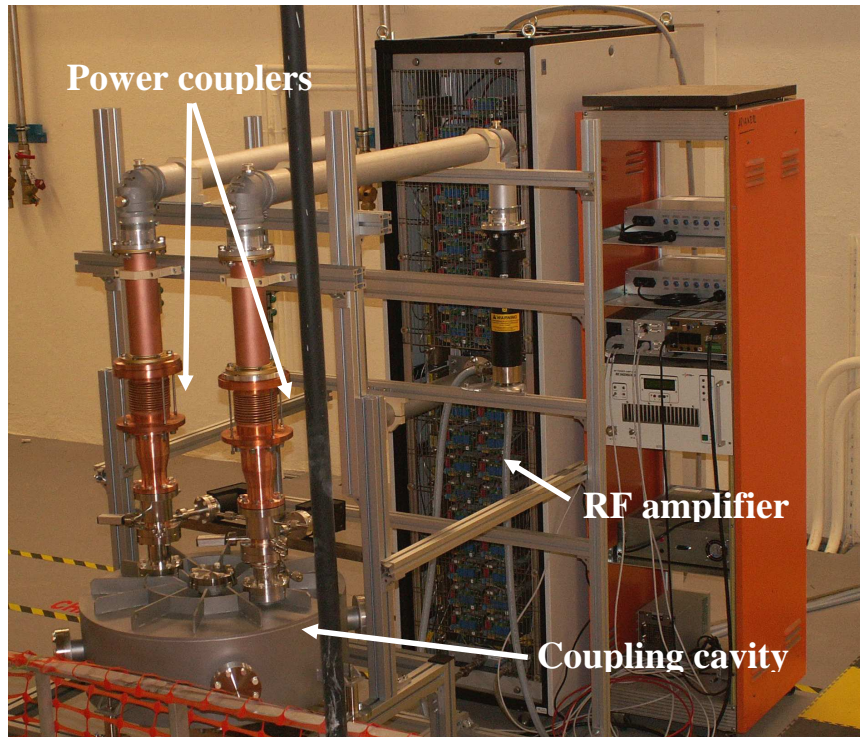



Figure 5: Power coupler conditioning bench during operation at 10 kW

RIDS 515768	TASK: 8	DATE:	
DELIVERABLE: D5		PAGE 4	