



European Coordination for Accelerator Research and Development

PUBLICATION

A 2-D LASER-WIRE SCANNER AT PETRA-III

Aumeyr, T (RHUL) *et al*

12 October 2010

The research leading to these results has received funding from the European Commission under the FP7 Research Infrastructures project EuCARD, grant agreement no. 227579.

This work is part of EuCARD Work Package 9: **Technology for normal conducting higher energy linear accelerators.**

The electronic version of this EuCARD Publication is available via the EuCARD web site <<http://cern.ch/eucard>> or on the CERN Document Server at the following URL :
<<http://cdsweb.cern.ch/record/1299157>>

A 2-D LASER-WIRE SCANNER AT PETRA-III*

T. Aumeyr[†], G. A. Blair, S. T. Boogert, G. Boorman, A. Bosco, JAI, Egham, Surrey
 K. Balewski, E. Elsen, V. Gharibyan, G. Kube, S. Schreiber, K. Wittenburg, DESY, Hamburg

Abstract

The PETRA-III Laser-wire, a Compton scattering beam size measurement system at DESY, uses an automated mirror to scan a Q-switched laser across the electron beam and is developed from the system previously operated at PETRA-II. This paper reports on recent upgrades of the optics, vacuum vessel and data acquisition. First beam profile measurements are also presented.

INTRODUCTION

Laser-wire (LW) beam profile monitors will be the key beam diagnostic instruments for future very high energy/intensity particle accelerators to replace the use of traditional profiling techniques such as wire scanners or screens. LWs can be employed in synchrotron light sources [1], linear electron-positron colliders [2], and most recently H⁻ ion accelerators [3].

The principle of operation of a LW profiler is to map the spatial distribution of the particle bunch by using the signal produced in the collision between the particles and the photons of a laser beam scanned across the accelerated beam. In electron machines, using the Compton effect, the laser photons are scattered by the electrons and can be detected downstream as gamma rays in a calorimeter. At H⁻ machines, where the fundamental process is photo-ionization of the H⁻ ion to form neutral H-atoms, the released electrons can be detected downstream.

The LW system is an upgrade of the two-dimensional LW tested previously at the PETRA-II accelerator [1]. The updated LW includes features to make measurements more reliable, such as real time correction for laser pulse-to-pulse power fluctuation and time or position jitter. Furthermore, knife-edge scans to measure the laser spot size as it is at the interaction point (IP) can be performed on-demand, allowing the user to extract the contribution of the laser width from the total signal distribution.

The relevant beam parameters of PETRA-III are gathered in Table 1. Also the expected horizontal and vertical beam sizes at the LW IP are stated.

Table 1: Nominal PETRA-III parameters [4],[5]

Parameter	Value	Unit
Energy E	6	[GeV]
Circumference C	2304	[m]
Horizontal emittance ϵ_x	~ 1	[nmrad]
Vertical emittance ϵ_y	~ 0.01	[nmrad]
Revolution frequency f	130.2	[kHz]
Bunches per fill N_{fill}	960 (40)	
Interbunch spacing	8 (192)	[ns]
Bunch length RMS L_b	~ 12	[mm]
Electrons per bunch N_e	0.25 (12)	$\cdot 10^{10}$
Exp. hor. beam size σ_x	~ 175	[μm]
Exp. vert. beam size σ_y	~ 15	[μm]

SETUP

In Fig. 2, a plan overview of the LW experimental layout on the south-west bending arc of the PETRA-III ring is shown. It illustrates the major components of the LW system: high power laser, optical scanning systems, beam position monitor (BPM) and Compton calorimeter.

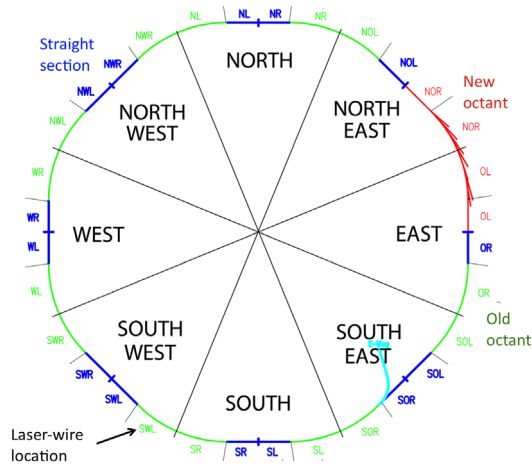

Figure 1: LW location at the PETRA-III facility.

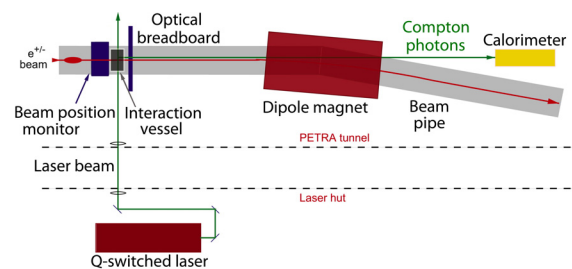

Figure 2: Overview of the LW setup [1].

The LW system described in this paper was built at the PETRA-III accelerator at DESY in Hamburg (see Fig. 1).

* Work supported by the EU under contract PITN-GA-2008-215080.

[†] t.aumeyr@rhul.ac.uk

downstream from the particle beam by a dipole magnet. After separation, the Compton photons exit the beam pipe through an aluminium window to reduce the synchrotron radiation background and are detected by a calorimeter. The photon detector is made of nine lead tungstate crystals organised in a 3×3 matrix which is optically connected to a photo-multiplier [1]. The position of the positron beam on either side of the IP is measured by a four-button pick-up BPM.

A Q-switched Nd:YAG laser system with a repetition rate of 20 Hz is used to produce the high power light pulses required for Compton scattering. The laser beam is expanded and collimated to approximately 25 mm diameter and transported from the laser hut into the accelerator tunnel underneath. The laser beam is then guided onto the LW breadboard mounted around the beam pipe, which contained the vertical (V) and horizontal (H) scanning systems. The LW scanning unit consists of a piezo-electric driven mirror that deflects the laser beam before it is focused by the scanning lens.

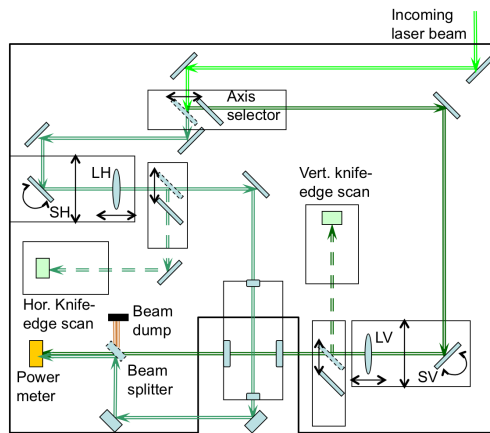

Figure 3: Schematic layout of the vertical breadboard.

Fig. 3 and Fig. 4 show a schematic of the optical layout and a photo of the LW breadboard respectively. The arrows indicate movable transition stages. For the LW scanning system, two scanning lenses were chosen with different focal length. This was a necessary upgrade in order to match the different beam sizes and scan range requirements in the two profiling directions (V and H). The focussing lenses are an aplanatic lens with $f = 250$ mm (LV) and a spherical singlet lens with $f = 750$ mm (LH).

The scanning axis (V or H) is set by the position of the first movable mirror. The scanning mirrors (SV and SH) are identical for both axes. These are 2-inch mirrors mounted on a piezo-electric stack that can be deflected by applying a voltage. The maximum deflection angle is 2.5 mrad with an applied voltage of 100 V. Given the focal lengths of 250 mm and 750 mm, the total maximum scanning range is 1.25mm for the V axis and 3.75 mm for the H axis.

Due to the longer focal length of the horizontal profiler lens, and the consequent increment of the laser Rayleigh range, the spot size at the input window of the old vacuum

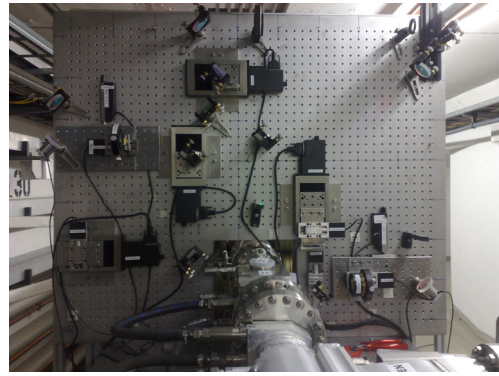

Figure 4: Photo of the LW optical breadboard.

vessel was too small and the intensity definitely above the damage threshold of the window. An extension of the vacuum vessel was therefore necessary in order to move the input window further away from the focus of the laser beam and work in safe conditions. Simulations showed that the new extended vessel does not introduce unacceptable RF fields.

DATA ACQUISITION SYSTEM

In Fig. 5, a schematic overview is shown of the LW data acquisition (DAQ) and the interface between the LW and the PETRA-III control room (BKR). The overall command part (LWCMD) issues scan commands (and sets timing and power). The actual data acquisition (LWDAQ) does the scan and returns the file produced to LWCMD, which in turn sends the filename to the analysis (LWANA). A camera is used to determine the laser pointing stability (LWCAM). This will also send its own data to LWCMD and be forwarded to LWANA. Once LWANA has analysed both files, the results are returned to LWCMD, displayed and sent to the DESY three-fold integrated networking environment (TINE) database via a TINE interface (LWTINE). LWCMD will eventually receive commands from BKR via the TINE database [6]. All communication is performed using LabVIEW Shared Variables.

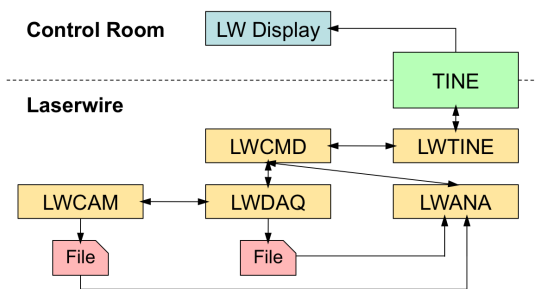

Figure 5: Interface between LW and BKR.

The LW DAQ system uses a National Instruments (NI) PXI system with a 2 GS/s two-channel digitizer (PXI-5152), a precision timing module (PXI-6653) and

a general-purpose DAQ (PXI-6251). Other hardware is accessed via RS232 and GPIB. Furthermore, the TINE database is read for beam data, such as local BPM positions and beam current. The DAQ software is written using NI LabVIEW (v8.5) with Statechart and DSC modules, for both the control of the LW and the online analysis of the data. The DAQ system also controls the translation stages used for beam-finding and focus position movement.

DATA TAKING AND RESULTS

The LW can operate two types of transverse scans:

- *Ramp scan* - A transverse scan using the piezo-driven mirror while keeping the beam-finding and focus-positioning translation stages fixed. It has a step resolution of less than $1\mu\text{m}$. As mentioned before, the scanning range is dependent on the scanning axis. Once the translation stages are moved into place, the scan rate is only determined by the laser repetition rate. Therefore, a fast scan can be performed: 20 steps and 10 shots per step would only take 10 s.
- *Stage scan* - A transverse scan using the motorised beam-finding stage with the piezo-mirror fixed has the same step resolution as a ramp scan. However, the scanning range is much larger (about 25 mm) but there is a 500 ms overhead for stepping the stages. A scan with 20 steps and 10 shots per step would take about 20 s

The position of the laser focus relative to the beam can be moved by the focus-positioning translation stage. Then either a ramp scan or stage scan may be performed to measure the beam size.

In addition, a knife-edge scan to check the waist size and Rayleigh range of laser can be performed. Furthermore, the laser timing and laser power can be adjusted.

Profile Measurements

Example profile measurements in the vertical and horizontal axes are shown in Fig. 6 and Fig. 7. The PETRA-III bunch pattern during both scans was a single bunch fill and both scans were measured with a stage scan. This provides a more accurate account of the transverse position and it will be used to calibrate the LW when working in ramp scan mode.

The vertical profile scan uses 40 laser positions and the signals from 20 laser shots are averaged for each position. At the laser repetition rate of 20 Hz, this scan took 60 s to complete. The bunch current was $260\mu\text{A}$. The horizontal profile scan uses 30 laser positions and the signals from 100 laser shots are averaged for each position. This scan took 165 s to complete. The bunch current was $690\mu\text{A}$.

The vertical and horizontal measured profiles have dimensions of $30.38 \pm 1.43\mu\text{m}$ and $293.6 \pm 18.1\mu\text{m}$ respectively. The profiles represent the transverse size of the positron bunch convoluted with the laser beam profile and

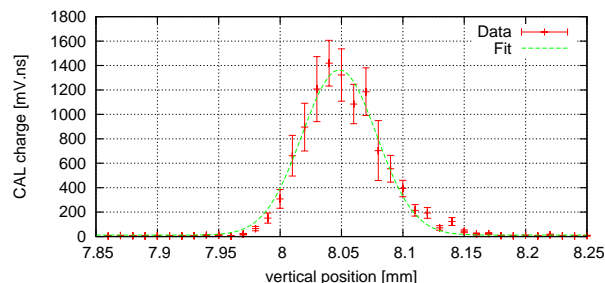

Figure 6: Vertical scan ($\sigma_y = 30.38 \pm 1.43\mu\text{m}$).

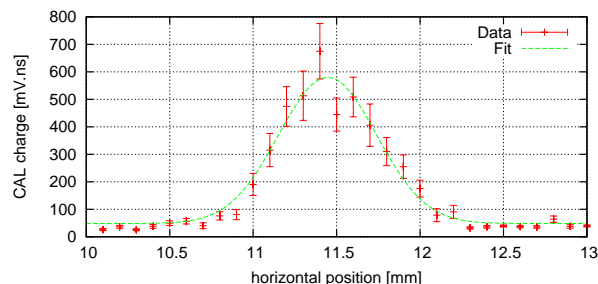

Figure 7: Horizontal scan ($\sigma_x = 293.6 \pm 18.1\mu\text{m}$).

the laser pointing jitter. These effects have to be precisely measured in order to extract the real positron beam dimensions. However, the discrepancy of about a factor of 2 compared with the expected beam sizes still requires further investigation.

CONCLUSIONS AND OUTLOOK

The PETRA-III LW system has successfully performed horizontal and vertical beam size measurements. The resolution of a beam profile scan is currently about 5%. The achieved scan times are 60 s and 165 s for the V and H axis respectively. Using the piezo-driven mirror, these times could be reduced down to values of the order of tens of seconds for each profiling axis, making the LW is a fast two-dimensional beam profiling instrument.

The next steps are the integration of the LW system into the PETRA-III control system and performing various benchmarking beam studies, e.g. to measure the lattice characteristics (dispersion, compaction factor, beta functions, etc.), compared with other beam size diagnostic instruments [7].

REFERENCES

- [1] A. Bosco, et al., Nucl. Instrum. Methods Phys. Res. A 592 (2008) 162.
- [2] I. Agapov, et al., Phys. Rev. ST Accel. Beams 10 (11) (2007) 112801.
- [3] Y. Liu, et al., EPAC08, TUPC061, 2008.
- [4] I. Ascone, et al. PETRA-III Technical Design Report (2004).
- [5] K. Balewski, et al., EPAC04, THPKF021, 2004.
- [6] P. Bartkiewicz, et al., Meas. Sci. Technol. 18 (2007) 2379
- [7] G. Kube, et al., these proceedings, MOPD089, 2010.