

## Sub-NM Beam Motion Analysis using a Standard BPM with High Resolution Electronics

**M. Gasior; M. Guinchard; A. Kuzmin; J. Pfingstner; H. Schmickler;  
M. Sylte, CERN – Geneva/CH**

**M. Billing, Cornell University - Ithaca/New York**

**M. Böge; M. Dehler, PSI - Villigen/CH**

### Abstract

In the Compact Linear Collider (CLIC) project high luminosity will be achieved by generating and preserving ultra low beam emittances. It will require a mechanical stability of the quadrupole magnets down to the level of  $1 \text{ nm}_{\text{rms}}$  for frequencies above 1 Hz throughout the 24 km of Linac structures. Studies are presently being undertaken to stabilize each quadrupole by means of an active feedback system based on motion sensors and piezoelectric actuators. Since it will be very difficult to prove the stability of the magnetic field down to that level of precision, an attempt was made to use a synchrotron electron beam as a sensor. The beam motion was observed with a standard button Beam Position Monitor (BPM) equipped with high resolution electronics. Beam experiments were carried out to qualify such a measurement at CsrTA (Cornell University) and at SLS (PSI, Villigen), where the residual motion of the circulating electron beams was measured in the frequency range of 5 – 700 Hz. This paper describes the results achieved along with the equipment used to measure both the residual beam motion and the mechanical vibration of machine elements.

# SUB-NM BEAM MOTION ANALYSIS USING A STANDARD BPM WITH HIGH RESOLUTION ELECTRONICS

M. Gasior, H. Schmickler, J. Pfingstner, M. Sylte, M. Guinchard, A. Kuzmin, CERN, Geneva  
M. Billing, Cornell University, Ithaca, New York  
M. Böge, M. Dehler, PSI, Villigen

## Abstract

In the Compact Linear Collider (CLIC) project high luminosity will be achieved by generating and preserving ultra low beam emittances. It will require a mechanical stability of the quadrupole magnets down to the level of  $1 \text{ nm}_{\text{rms}}$  for frequencies above 1 Hz throughout the 24 km of linac structures. Studies are presently being undertaken to stabilize each quadrupole by means of an active feedback system based on motion sensors and piezoelectric actuators. Since it will be very difficult to prove the stability of the magnetic field down to that level of precision, an attempt was made to use a synchrotron electron beam as a sensor. The beam motion was observed with a standard button Beam Position Monitor (BPM) equipped with high resolution electronics. Beam experiments were carried out to qualify such a measurement at CEsrTA (Cornell University) and at SLS (PSI, Villigen), where the residual motion of the circulating electron beams was measured in the frequency range of 5–700 Hz. This paper describes the results achieved along with the equipment used to measure both the residual beam motion and the mechanical vibration of machine elements.

## MOTIVATION

For all new electron beam based light sources the present “race” is for always smaller beam emittance. The linear collider and FEL projects aim for even smaller beam emittances, such that mechanical vibrations of the quadrupoles start to contribute significantly to the increase of beam emittance during the passage of the beams through the linac. Extensive computer simulations [1] have been carried out for the CLIC project leading to the specifications of the required stability of the magnetic axis of the CLIC main linac quadrupoles listed in Table 1.

The required stability is at least one order of magnitude smaller than what can be achieved by passive damping and shielding of ground motion and technical noise. The present baseline for the CLIC project is an active stabilization system based on motion sensors for 5 degrees of freedom on each quadrupole and piezoelectric actuators in a closed feedback loop for stabilization [2]. It is expected that with this setup the quadrupoles can be

Table 1: CLIC project requirements for residual quadrupole stability above the limiting frequencies

Plane	Final focus quads	Main beam quads
Vertical	$0.18 \text{ nm} > 4 \text{ Hz}$	$1 \text{ nm} > 1 \text{ Hz}$
Horizontal	$5 \text{ nm} > 4 \text{ Hz}$	$5 \text{ nm} > 1 \text{ Hz}$

mechanically stabilized to the required precision. One point in this approach is left open, namely whether the mechanical stabilization of a quadrupole also assures that the magnetic centre of this quadrupole is stable to the same level. Potentially coil vibrations due to coolant flow or pole tip vibrations might change the magnetic centre. Hence in the framework of the actual R&D program additional instrumentation is being developed, which would allow sensing the stability of a quadrupole down to the required level of precision. For the final experiment the stabilized quadrupole would have to be inserted into that machine, the beam steered through it with a large excursion, whilst the beam in all other quadrupoles would be steered to the minimum possible offset.

This paper describes pilot measurements on two synchrotron light sources exploring whether an electron beam could be used as a sensor of the quadrupole magnetic field stability. In simple experiments the residual eigen-motion of the electron beam was observed and beam spectra including the region of interest 5–100 Hz have been recorded. In order to obtain a noise floor below the nano-meter level an optimized copy of the LHC Base Band Tune (BBQ) measurement hardware [3, 4] was used with observation periods up to many minutes.

The following chapters contain description of the front-end electronics used, results from the beam experiments at CEsrTA and SLS and preliminary conclusions whether an electron beam in a synchrotron could be used as a gauge for demonstrating quadrupole stability down to the nano-meter level.

## HIGH RESOLUTION BPM ELECTRONICS

Beam signals were taken from standard button BPMs “borrowed” from their native systems (orbit or transverse feed-back) for the time of experiments. The individual button signals were processed with a copy of the LHC BBQ hardware based on the direct diode detection (3D) technique [3, 4]. The principle of the technique is shown schematically in Fig. 1, with the simplified signal waveforms sketched above the characteristic nodes of the circuit.

In this scheme the pick-up electrode signals are processed by diode peak detectors, which can be considered as fast sample-and-hold circuits, with the sampling self-triggered at the bunch maxima and “held” by the parallel capacitors. The purpose of the parallel resistors is to slightly discharge the capacitors so that the next bunch with potentially smaller amplitude

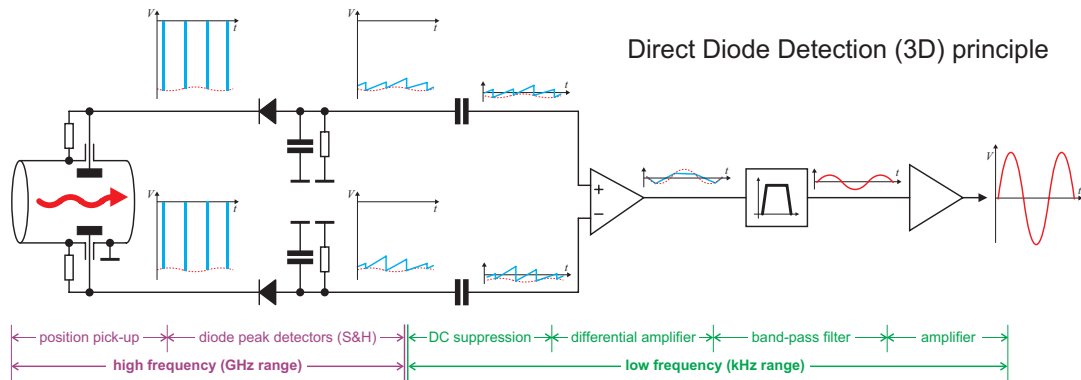

Figure 1: Direct diode detection principle with simplified signal waveforms in the key nodes of the circuit.

also contributes to the detector output signal. The series capacitors remove the DC components corresponding to the beam offset, which otherwise would take most of the dynamic range of the following acquisition or even they would have to be attenuated, together with the carried modulation, as the DC components can be as large as a few tens of volts. With the large DC part suppressed, the low frequency small beam motion signals can be amplified and filtered prior to digitalisation, which was done with 24-bit NIM digitisers [5], based on audio codecs. The digitisers were connected to an FPGA-based VME digital acquisition board (DAB) [6], performing data buffering, sample windowing and calculating spectra through the FFT analysis. Such an acquisition system, developed specifically for the LHC BBQ systems, is capable of delivering 64K-point magnitude spectra of 160 dB dynamic range [3].

The LHC BBQ system operates in the range of 0.5 – 5 kHz with proton bunches  $\approx 1$  ns long. For the experiments presented here the system components, namely diode detectors, analogue front-end and 24-bit digitisers were modified for optimal performance in the band 5 Hz – 1 kHz with much shorter electron bunches. This modified system is referred to in the paper as the low frequency BBQ (LF-BBQ).

The sensitivity of the 3D technique for beam motion observation is achieved at the expense of rejecting beam offset and intensity information, resulting in absence of amplitude scale for the beam motion. Since the experiments required absolute amplitude calibration, the high dynamic range of the system was used for a dedicated calibration procedure.

In this procedure an electromagnetic exciter, typically an orbit corrector, was driven at a given frequency with current yielding beam oscillations with amplitudes convenient for the existing BPM system for turn by turn measurements (micro-meter domain). This calibration oscillation was measured in parallel with the BPM system (calibrated in mm) and the LF-BBQ hardware yielding a measurement with a calibrated amplitude. Then the excitation level was lowered in decades and the linear response of the LF-BBQ system was verified. During all the measurements a permanent excitation tone at 20 Hz was left on at a convenient amplitude level for data cross-calibration.

## VIBRATION MEASUREMENTS

Several high resolution vibration sensors were installed for the measurements for two purposes:

- contributing to a world-wide campaign of documenting ground motion effects in accelerators domains;
- verifying that the observed beam rest-motion was not caused by vibrations of the BPM itself.

The experimental setup can not be described in this paper and the reader is referred to [7] and [8]. It was verified that the BPM vibration amplitudes were too small to be important for the measurement results of the described experiments.

## EXPERIMENT AT CESR-TA

Beam measurements took place in June 2009. Four diode detectors were installed directly on each port of a standard CesrTA orbit button pick-up. Two detectors of the top and bottom left buttons were connected with two  $\approx 1$  m long coaxial cables to the first differential input of the analogue front-end, and the two detectors of top and bottom right buttons were connected with another two cables to the second differential input of the front-end. In this way two independent measurement channels were formed. As the beam was usually close to the pick-up centre, both channels were sensitive to both, horizontal and vertical beam motion. In the presented CesrTA measurements averages of both channels are shown. The outputs of the analogue front-end were connected to the 24-bit digitiser with two  $\approx 20$  m long coaxial cables. The digitisers, together with the DAB in a VME crate, were located in a “data collecting room”, together with the experiment crew. Data was processed on a laptop running a LabView application, collecting data from the DAB through a VME-USB bridge.

The ADCs were clocked at 44.1 kHz and every 32 samples were replaced by their average to improve signal to noise ratio (SNR), resulting in the equivalent sampling rate of 1403 Hz. One “single” measurement consisted of taking 64 K samples during  $\approx 47$  s. A “full measurement”, lasting  $\approx 17$  minutes, consisted of taking 22 single measurements and calculating their average, in order to decrease the variance of the spectra.

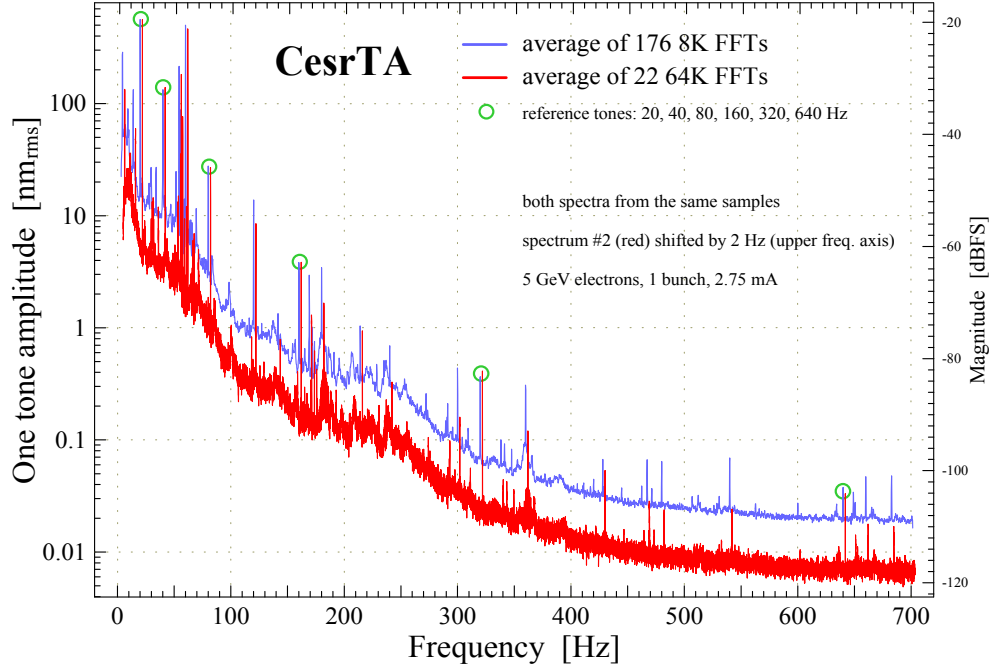

Figure 2: Typical CsrTA beam spectra.

For the amplitude calibration a vertical orbit corrector was used as an exciter. The corrector was disconnected from its native system and cabled to the “data collecting room”. It was driven with a sinusoidal current of  $0.5 A_{\text{rms}}$  at 20 Hz while the electron beam at 2 GeV was circulating in the machine. This excitation gave an oscillation amplitude of  $100 \mu\text{m}_{\text{rms}}$  at the LF-BBQ pick-up location extrapolated from data of the CsrTA BPM system and scaled with the lattice functions.

Typical CsrTA beam spectra are shown in Fig. 2, taken with “as quiet beam as possible”, i.e. with all feed-back systems off and at moderate beam intensity. Both shown spectra are calculated from the same beam signal samples with different processing. The spectrum with lower noise floor (red) is an average of 22 64K-point FFTs and the second spectrum is an average of 176 8K-point FFTs. The 8K spectra were calculated by dividing each of the 64K-sample records into 8 8K segments then processed separately. All samples are Hanning windowed prior to FFT processing, otherwise the spectral leakage would mask small components in the second half of the observation bandwidth. For the presented measurement 6 reference tones were used, namely at 20, 40, 80, 160, 320 and 640 Hz (green circles on the plot), with the excitation current of  $7 \text{ mA}_{\text{rms}}$  per component, resulting in the beam oscillation amplitude of  $560 \text{ nm}_{\text{rms}}$  at 20 Hz, scaling the left amplitude axis. The right amplitude axis is in dB with respect to the ADC full scale (FS). Both spectra have frequency axis shifted by 2 Hz so that the corresponding components do not overlap, but instead they are side-by-side for better amplitude comparison.

The spectra of Fig. 2 are in fact spectral amplitude densities and the time-domain amplitude measured during the calibration is their RMS integral. Nevertheless, the amplitude axis is scaled in nano-meters, which should be

understood as the amplitude which would be obtained if the spectral density around a given single-tone peak was integrated. Therefore, the amplitude scale is true only for single tone components, stressed by the name of the amplitude axis. This “amplitude scale convention” was found the most representative for presenting results of the experiments. For obtaining time-domain amplitudes of any other signals than single tones a proper integration should be done, which was the case for the integrated RMS amplitudes discussed in the conclusion chapter.

By comparing the 8K and 64 K spectra of Fig. 2 it is possible to distinguish coherent and incoherent components, as amplitudes of incoherent components decrease with increasing FFT length. The other large coherent components (i.e. with similar amplitudes on both spectra) are at 60 Hz (mains harmonics) and 54 Hz. Incoherent large components are at 4.4 Hz and 13.8 Hz.

The noise floor difference between the 8 K and 64 K should be  $\sqrt{8}$  i.e.  $\approx 9$  dB. This value is seen towards the end of the observation range, but for some, typically quite narrow, components the difference is smaller, i.e. such components are coherent only to a certain extend.

It is seen that the amplitudes of the 40, 80, and 160 Hz tones decreases with frequency ( $f$ ) approximately like  $f^{-2}$ , (amplitude difference between the tones: 12, 14, 17 and 41 dB), which cannot be explained by the LF-BBQ frequency characteristic, measured in the lab to be flat within the observation bandwidth. Also it cannot be explained only by the inductance of the corrector coil (12 mH), giving with the driving source impedance the cut-off frequency of 160 Hz. However, it is certain that the attenuation of the exciter magnetic field through eddy currents in the Al vacuum chamber contributes significantly to this attenuation. A quantitative analysis of the attenuation was not carried out.

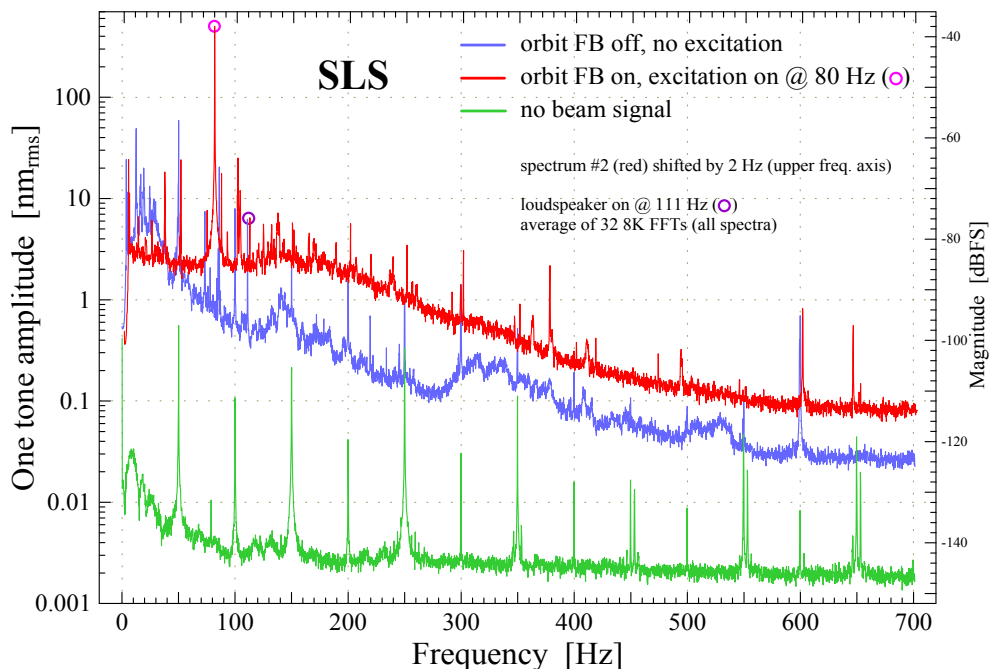

Figure 3: SLS spectra with the orbit feed-back on and off, along with a spectrum without beam.

The frequency range of interest for CLIC stabilization is 5 Hz – 100 Hz, since the excitation due to ground motion falls off rapidly with the square of the frequency. In this range the residual eigenmotion of the CsrTA beam is well above the nano-meter level, so it was concluded to repeat the experiment at an European light source, which was constructed much later and for which specific attention had been paid on stability.

## EXPERIMENT AT SLS

Beam measurements took place in October 2009. As beam sensors two button pick-ups were used, one “borrowed” from the orbit system and one from the transverse feed-back system ( $\approx 3$  m distance between the pick-ups). One top and one bottom port of each pick-up were equipped with the diode detectors, which were then connected to two differential inputs of the analogue front-end with a few m coaxial cables.

For the beam measurements at the SLS the same LF-BBQ hardware was used, with a few modifications improving further its sensitivity.

Beam excitation was done with an orbit corrector which was driven with a sine wave excitation generated by the control system. Its strength was calibrated with the BPM system at 80 Hz, high enough to be outside of the bandwidth of the orbit feed-back, which had to be on during the excitation. Due to smaller beam availability than at Cornell, the standard measurement configuration was 32 measurement of 8K samples each, taking  $\approx 3$  minutes.

Spectra from three such measurements with the channel of the orbit feed-back pick-up are shown in Fig. 3. One measurement was done with the excitation of 500  $\text{nm}_{\text{rms}}$  at 80 Hz, the second is a corresponding measurement with the excitation and orbit feed-back off and the third is a

reference measurement without beam. The two beam measurements were taken during the same beam store and beam conditions and the reference measurement was taken with the same settings of the analogue front-end as the beam measurements.

It is seen that the orbit feed-back attenuates the low frequency components (with a not understood exception around 4 Hz) while amplifying noise above its design bandwidth.

To excite the beam with mechanical vibrations in a controlled way, a loudspeaker was put on the machine floor near the pick-up used for the experiment. During measurements it was driven with a single tone, typically at 111 Hz, and the resulting beam oscillation is visible in the spectra of Fig. 3.

The spectrum measured without beam shows noise and interference of the electronics measured in the same conditions as the other two beam measurements. In the spectra strong interference from mains harmonics is seen, captured by the coaxial cables connecting the diode detectors with the front-end ( $\approx 2$  m) and the front-end with the digitisers ( $\approx 20$  m). With better cables and the digitisers much closer to the front-end this interference most likely could be significantly lowered.

Noise floor of the LF-BBQ electronics without and with beam should be similar, as the detector diodes most of the time are not conducting, turning on only with the beam pulses at amplitudes close to the beam peak voltage. For comparison the measured BBQ spectrum without beam was put on the same absolute amplitude as the other two measurements. The noise floor above 100 Hz is  $\approx 3 \text{ pm}_{\text{rms}}$ , raising to  $\approx 30 \text{ pm}_{\text{rms}}$  towards 10 Hz measured with the FFT bin width of  $\approx 86 \text{ mHz}$ . The corresponding noise densities are  $\approx 10 \text{ pm}/\sqrt{\text{Hz}}$  and  $\approx 100 \text{ pm}/\sqrt{\text{Hz}}$ , respectively.

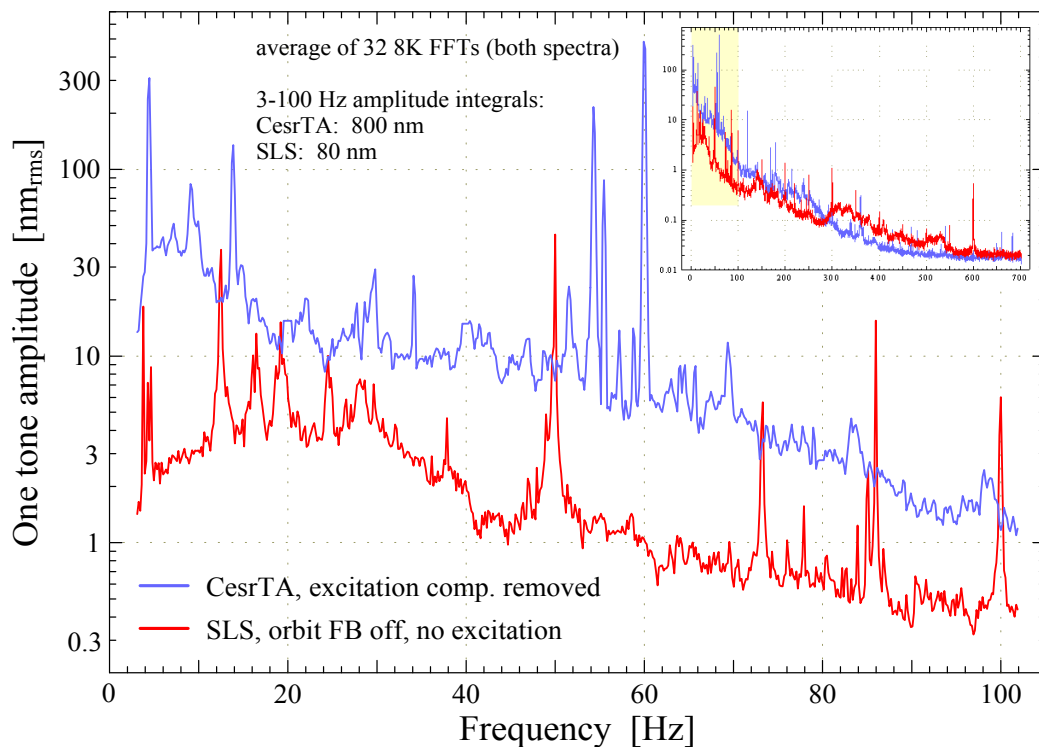

Figure 4: Comparison of CesrTA (excitation tones removed) and SLS spectra, shown in Fig. 2 and 3, respectively.

## CONCLUSIONS

The spectra from both experiments at corresponding conditions are shown for comparison in Fig. 4. For this purpose the excitation tones were artificially removed from the CesrTA spectrum. The integrated beam motion for the plotted frequency range are 800 nm<sub>rms</sub> and 80 nm<sub>rms</sub> for CesrTA and SLS, respectively.

The defined objectives for this series of measurements had been to determine whether with the simple setup of high sensitivity BPM electronics and an electron beam of about 10 micrometer size circulating in a synchrotron the mechanical stability of one quadrupole could experimentally be verified down to the nano-meter level. Unfortunately the answer is negative, as the residual eigenmotion of the electron beam is well higher than 1 nm<sub>rms</sub>, i.e. the integrated mechanical stability specification for the main beam CLIC quadrupoles for all frequencies above 1 Hz.

Since the difference to the target is quite high, the authors were discouraged to search for the origin of the beam rest-motion with the aim of compensating for the effect. A plausible candidate is electronic noise in the regulation loops of the quadrupole or bending magnet power converters and their impact on the closed orbit. Even if this hypothesis was correct, improving these regulation loops would be a considerable effort.

Future efforts will be directed to investigate the possibilities for installing the quadrupole under test in a beam extraction line with high beam duty cycle and with several BPMs before and after the quadrupole in order to be able to detect minimal changes in the beam deflection.

As a nice side product the diode-based BPM electronics, which had specially been developed for high sensitivity tune measurements, has successfully been extended to the very low frequency range and has given a noise performance which excels any other existing BPM electronics.

One can anticipate that in the near future circular light sources themselves might hit limits on their beams coming from residual mechanical vibrations of machine elements. For these cases the technique described in this paper may become a very useful diagnostics tool.

## REFERENCES

- [1] D. Schulte et al., "Adaptive Scheme for the CLIC Orbit Feedback", Proceedings of IPAC2010.
- [2] K. Artoos et al., "Study of the stabilization to the nanometre level of Mechanical Vibrations of the CLIC Main Beam Quadrupoles", Proceedings of PAC'09.
- [3] M. Gasior, R. Jones, "The Principle and First Results of Betatron Tune Measurement by Direct Diode Detection", CERN LHC Project Report 853, 2005.
- [4] M. Gasior, R. Jones, "High Sensitivity Tune Measurement by Direct Diode Detection", Proceedings of DIPAC'05.
- [5] A. Boccardi, M. Gasior, "High dynamic range spectral analysis in the kHz band", Proceedings of DIPAC'09.
- [6] A. Boccardi et al., "The FPGA-based Continuous FFT Tune Measurement System for the LHC (...)", Proceedings of PAC'07.
- [7] M. Sylte, "Vibration Measurements at CesrTA", internal CERN publication, EDMS 1004462, 2009.
- [8] A. Kuzmin, "PSI measurements", internal CERN publication, EDMS 1050039, 2009.