

Installation Of Mobile Tilted Foil Holder At REX - ISOLDE

M. Eriksson

Abstract

This document covers the findings from the installation of the mobile tilted foil system in the beam diagnostics boxes DB6 and DB7 in the 20° and 65° beamlines of REX-ISOLDE.

It describes:

- the various parts that make up the complete system
- how parts were assembled and aligned with respect to the beamline
- the test procedures
- the modifications that were carried out in order to further improve the functionality and overall performance of the assembled system

ORGANISATION EUROPÉENNE POUR LA RECHERCHE NUCLÉAIRE
CERN EUROPEAN ORGANIZATION FOR NUCLEAR RESEARCH

Installation Of Mobile Tilted Foil Holder At REX - ISOLDE

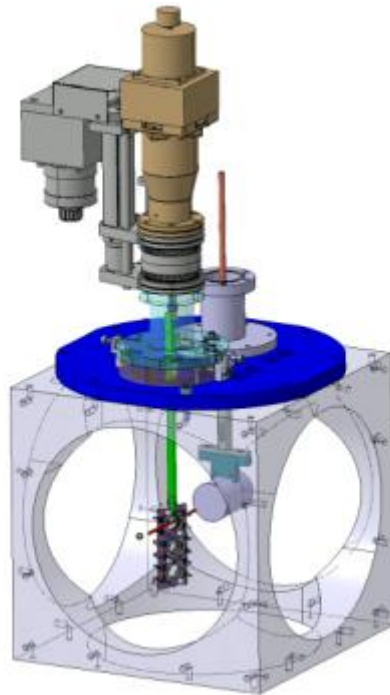

GENEVA
2009

Table of Contents

Table of Contents.....	4
Introduction	5
Acknowledgements	5
Dismantling the beam diagnostic box	6
Assembly of the multi tilted foil system.....	7
<i>Actuator and feed through:</i>	8
<i>Foil holder and foils:</i>	8
Alignment of the setup	11
Positioning of the foils.....	13
<i>Rotational positioning:</i>	13
<i>Vertical positioning:</i>	13
<i>Transverse positioning:</i>	14
<i>Longitudinal positioning:</i>	14
Findings during the alignment.....	14
Controls	16
<i>Stepper driver:</i>	16
<i>Control software:</i>	16
<i>Input file:</i>	17
Drawings.....	18
Modifications.....	19
<i>Stepper driver:</i>	19
<i>Input file:</i>	19
Last minute changes	19
<i>Location:</i>	19
<i>Foils:</i>	20
<i>Foil holder:</i>	20
<i>Alignment:</i>	20

Introduction

This document covers the findings from the installation of the mobile tilted foil system in the beam diagnostics boxes DB6 and DB7 in the 20° and 65° beamlines of REX-ISOLDE.

It describes:

- the various parts that make up the complete system
- how parts were assembled and aligned with respect to the beamline
- the test procedures
- the modifications that were carried out in order to further improve the functionality and overall performance of the assembled system

Acknowledgements

I'd like to thank everyone who helped in the making of this project and especially the following support-groups/people:

Manufacturing:

Dimitar Mladenov (PH/UAT), Ermanno Barbero (EN/STI), Michael Owen (EN/STI) and Julien Thiboud (PH/SME).

Radio Protection:

Alexandre Dorsival (DGS/RP).

Beams Instrumentation:

Morad Hamani (BE/BI), Michel Duraffourg (BE/BI) and Cathelijne Bal-Hazelaar.

Alignment:

Andre Froton, Jean-Christophe Gayde and Christian Lasseur (all BE/ABP).

Testing:

Janne Pakarinen (PH/SME), Hans Toshihide Törnqvist (PH/SME), Jarno Van De Walle (PH) and Georgi Georgiev (PH/UIS).

Supervisor:

Fredrik Wenander (BE/ABP)

Dismantling the beam diagnostic box

Externally the actuator for the Multi Channel Plate (MCP) acceleration plate had to be removed and compressed air cables disconnected.

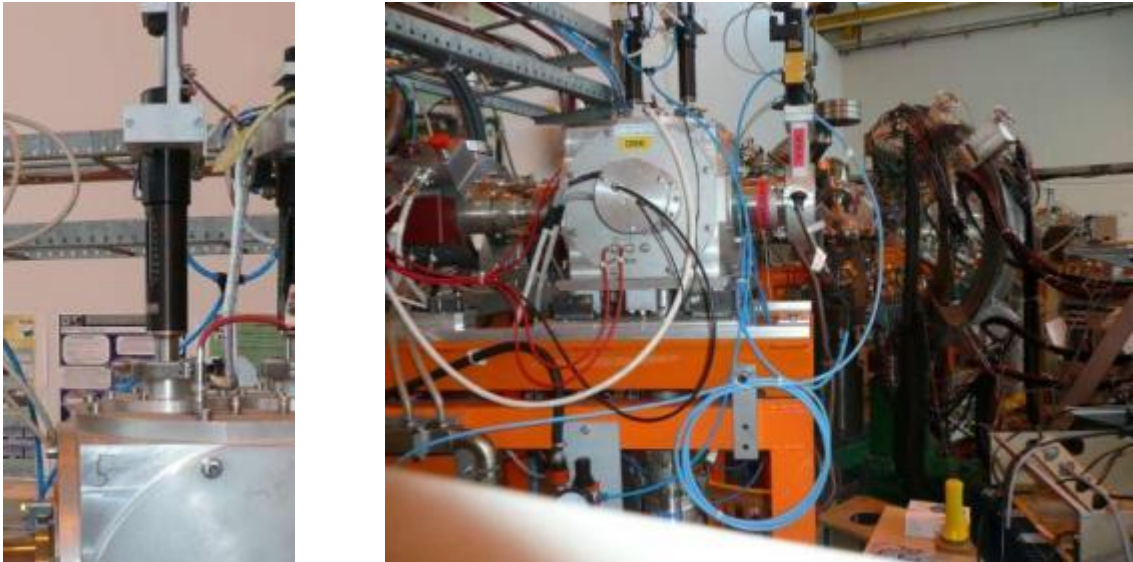

In order to fit the foil holder, both the MCP and its acceleration plate had to be removed from the BD-box interior.

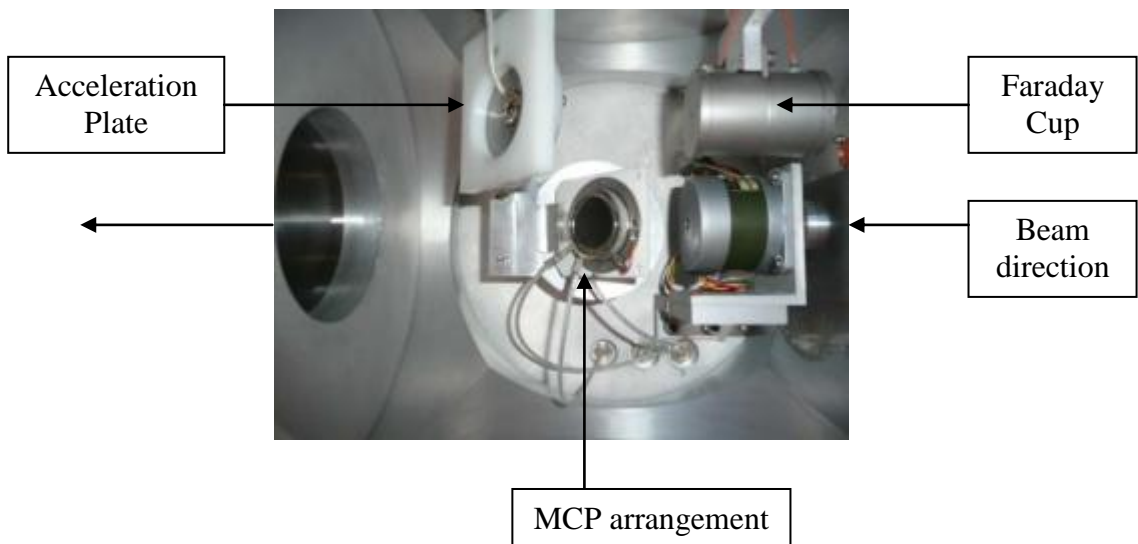

Assembly of the multi tilted foil system

The assembled system consists of seven major parts:

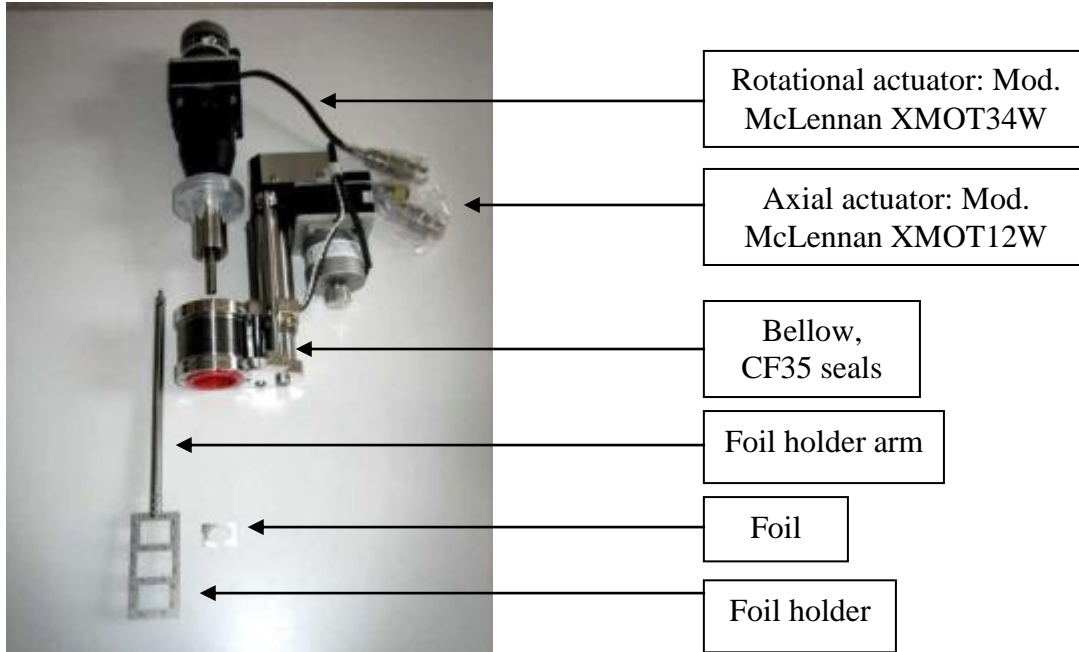

Actuators manufactured by: <http://www.mclennan.co.uk>

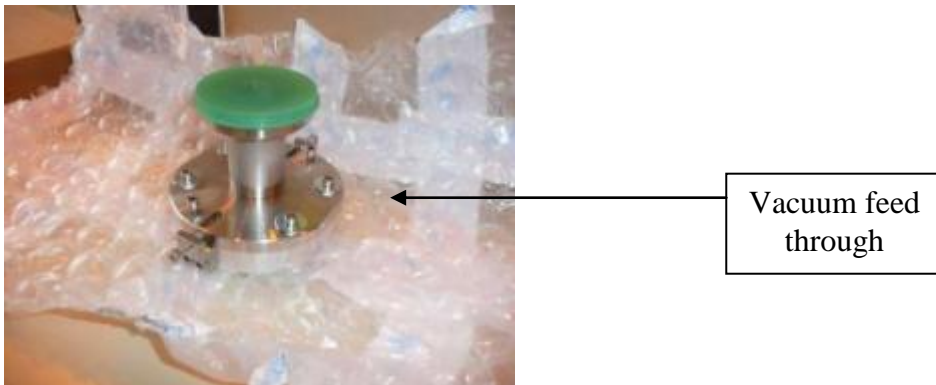

Actuator and feed through:

The rotational actuator was joined together with the bellow of the axial actuator unit.



Rubber o-rings of type:
Maagtechnic OR EPDM70 KTW 53.57x3.53 and OR EPDM70 KTW 78.97x3.53 were used for vacuum sealing of the vacuum feed through piece..

Considering the weight of the assembled foil holder system it is necessary to be two persons when mounting /dismounting the parts to the BD-box.

Image showing the complete system installed in the BD-box (DB6).

Foil holder and foils:

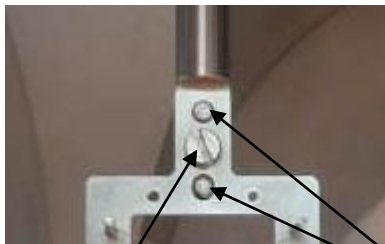

The foil holder is attached onto the lower flat part of the holder arm inside the BD-box. Two guidance rods assure that the foil holder is aligned to the rod and a single screw is then securing the plate to the foil holder arm.

Fixation
screw

The foil holder plate attached to the arm
and guided by the two guidance rods.

When securing the screw it is necessary to hold the arm so that the pressure applied when turning the screw does not break the actuator motor/bearing etc.

Before insertion and fixation of the foil holder it is necessary to mount the foils onto the 1mm thick foil holder plate.

The plate will house a flexible number of foils at three different positions.

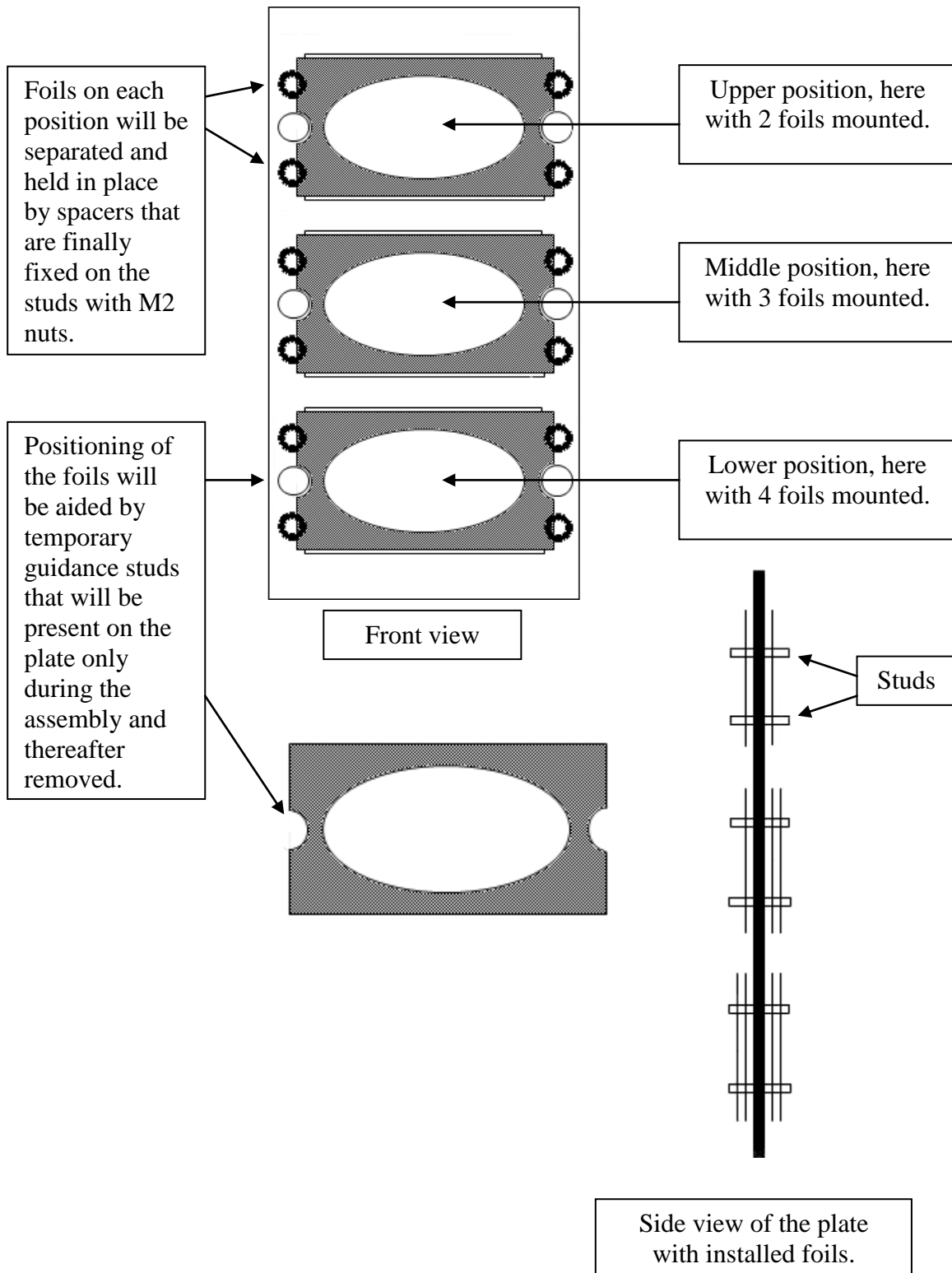



Great care during the assembling is mandatory as the frames are coated with thin carbon foils ($4\mu\text{g cm}^{-2}$) which are very brittle.

10mm studs

With the aid of the guidance rods and, by holding the plate slightly tilted so that a dropped spacer/nut falls onto the table and not onto the foil, one can minimize the risks of damaging the foils.

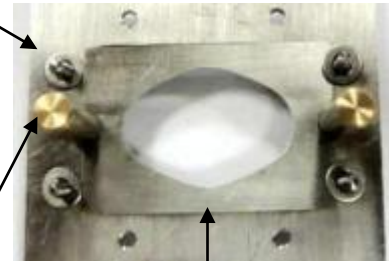

Guidance rod

Foil frame

Alignment of the setup

The foil holder setup mounted in the BD-box at the 20° beam line of REX, just after the separator magnet and close to the Miniball experiment.



The telescope with its tripod was aligned with respect to the extension of the beam line and the center of the 3mm collimator hole.

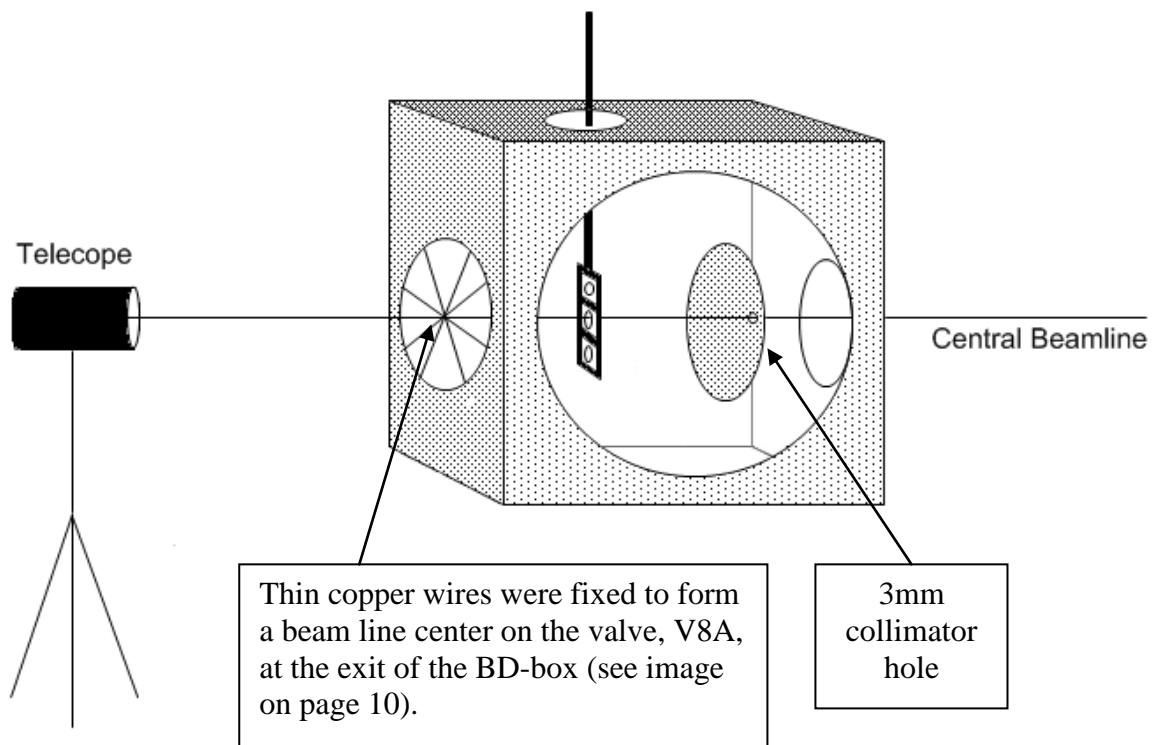

During the alignment work it became clear that the BD-box was not perfectly aligned itself; it was therefore decided to not use the copper wires at the exit as a center reference anymore but rather only the collimator hole.

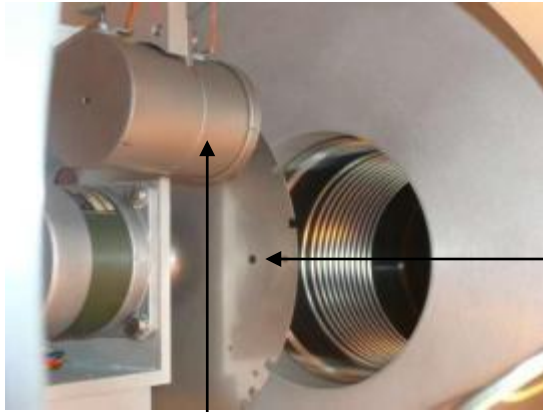
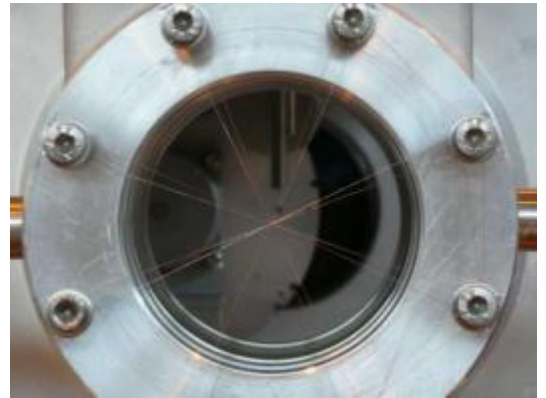

The motorized collimator disc with its 3mm hole located at the beam entrance of the BD-box

Faraday cup

Also seen in this picture is the Faraday cup that can be moved into the beam line from above.

To the right we see the foil holder mounted with the lower foil position in the center of the beam line, just before the exit of the BD-box.

In the background the camera used to grab the MCP image can be seen.

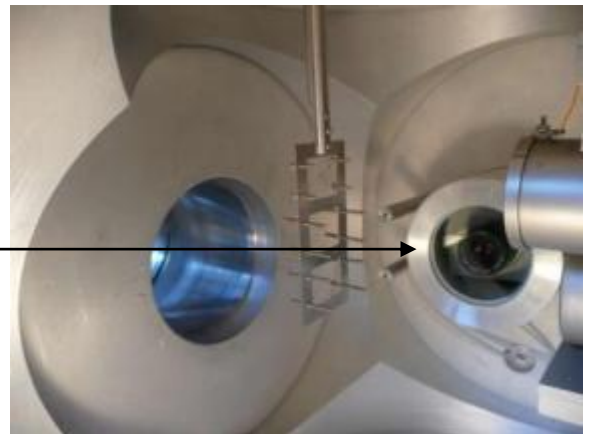

Positioning of the foils

Rotational positioning:



The rotation is operated with a knob located on the top of the rotational actuator.

To turn the foil holder 360° the knob needs to be turned 9 whole turns, in other words 1 lap equals to 40°.

A hole on the side of the knob was used as a visual reference point for the angular position as no other direct indicators are available.

Vertical positioning:

Moving the foil holder vertically is done manually by the knob located on the bottom of the second actuator. This knob has a very high resolution. Hence, moving the holder up and down becomes a time consuming job. A level indicator indicates the actual position in millimeters (image shows lower position).

The vertical positions for the three foil centers when installed in the XL20 beam line have been found to be:

- 94.5** (upper position, lower foil)
- 68** (middle position, middle foil)
- 41.5** (lower position, upper foil)



Transverse positioning:

It is necessary to slightly loosen the 6 screws that fix the feed through on the BD-box before any transverse adjustments can be done.

Note that the vacuum may be disrupted by such an operation and it should therefore only be done with the beam line under atmosphere.



The transverse positioning can be manually adjusted by turning 2 screws that hold the actuator/feed through in place. One of these screws can be seen in the image just to the left of the SHV connector named 'grid', the other one is located on the opposite side of the feed through.

Longitudinal positioning:

No adjustment freedom.

Findings during the alignment

During the design stage of this system it became clear that a perfect alignment would be difficult to achieve but a deviation limit of around $\pm 0.5\text{mm}$ still would be possible to reach. There are several sources in this design that can cause a misalignment and lead to operational issues, most have been identified and understood during the alignment process. Critical issues are:

- The straightness of the welds in the feed through.
- The straightness of the foil holder arm when attached to the actuator.
- The straightness of the foil holder plate when attached to the foil holder arm.
- The alignment of the foils to the foil holder plate.



For the alignment a thin copper wire was used when observing the holder perpendicularly, i.e. at 0° and 180° angle. At 90° and 270° angles the 1mm thick plate itself is used. The wires can not be used at an arbitrary angle due to the axial off-centering.

Since the rotational actuator on top of the BD-box mainly consists of moving parts we could not manufacture a fixation unit that would push the actuator into the wanted position. It was decided to bring a slight force on one of the sides of the feed through instead. The force was applied by a screw and a bolt that was put in place as seen in the image.

NB: We also find that by pushing the knob used for the rotation of the arm we would generate a transverse play at the lower end of the system of around 1-2mm. This was not the result of a faulty mounting or any broken part; it was even expected that this could occur during the design phase of this system.



Controls

In order to remotely control the foil holder, a single-axis stepping motor drive- and controller-system of type SIM-STEP was ordered from McLennan and later connected to the stepper motor and a PC running Microsoft Windows XP.

Stepper driver:



The SIM-STEP system consists of:

1	MSE570-Evo2 3.5A Stepper Driver
1	PM600 Motor Controller
1	MSB867 Backplane
1	MSE779 Power Supply Board

Manuals for the various components can be found at: <http://www.mclennan.co.uk>

Control software:

Control software for the stepping motors using the RS-232 protocol was provided by the manufacturer. The software was installed on the PC and input data (batch file in .txt format) feeding the software was written and optimized through numerous tests on site.



Input file:

The input file is basically a number of events that are specified in a .txt –file and then read by the application.

Below is the final file listed, yielding the smoothest operation for our setup:

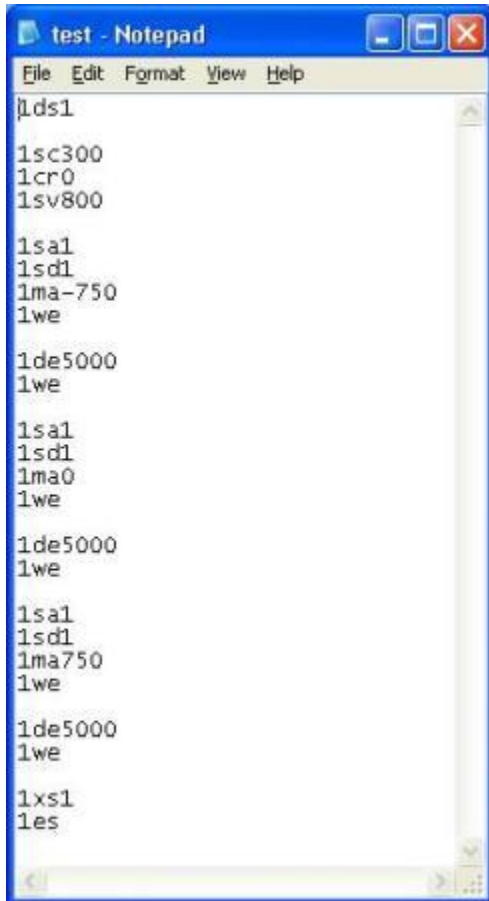

- 1ds1 = Seq.1, Scan for move inputs
- 1sc300 = Creep speed 300
- 1cr0 = Set creep to 0
- 1sv800 = Set rotational speed to 800
- 1sa1 = Acceleration, step/s²
- 1sd1 = Deceleration, step/s²
- 1ma-750 = Move to position -750 (-75deg)
- 1we = Wait for end of move
- 1de5000 = Delay 5 Sec
- 1we = Wait for end of move
- 1sa1 = Acceleration, step/s²
- 1sd1 = Deceleration, step/s²
- 1ma0 = Move to position 0
- 1we = Wait for end of move
- 1de5000 = Delay 5 Sec
- 1we = Wait for end of move
- 1sa1 = Acceleration, step/s²
- 1sd1 = Deceleration, step/s²
- 1ma750 = Move to position 750 (+75deg)
- 1we = Wait for end of move
- 1de5000 = Delay 5 Sec
- 1we = Wait for end of move
- 1xs1 = Goto Input scanning sequence 1
- 1es = End sequence 1

Drawings

Using CATIA, CERN's Design Office produced full 3D-models of the beam diagnostic with the tilted foil system installed. This made it possible to "test" the setup prior to the installation.

A 3D-model can be found in CERN's CATIA database (SmarTeam) with the following reference number: **ST0216588_01**

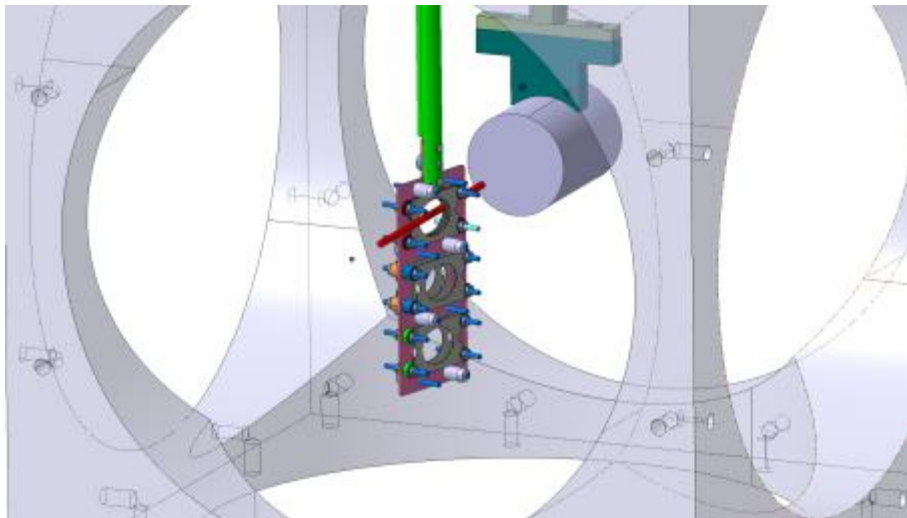
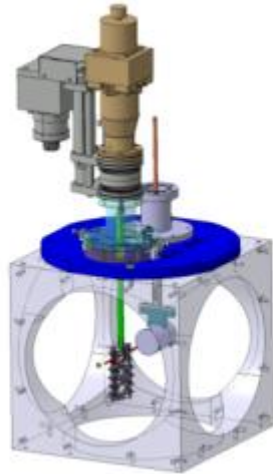

Modifications

Stepper driver:

The stepper driver was delivered with a driving current of 3.5A. This value caused a non-smooth operation of the stepping motor. By setting dip-switches internally this value could be lowered to the minimum of 0.5A, resulting in a smoother movement.

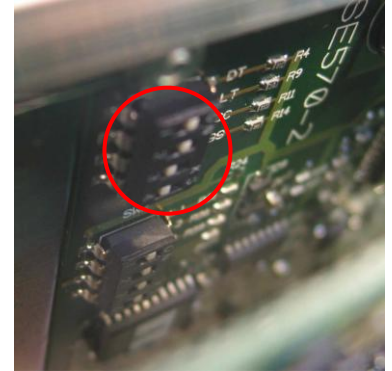

Input file:

The parameter “Creep Speed” was initially set to a value of 800. This was found too high and caused the stepping motor to transmit vibrations to the foil holder and the foils to break. By lowering the creep speed to a value of 300 we achieved a smooth operation of the setup. With the new setting we ran tests with the foils rotating between the two end positions ($\pm 80^\circ$) for 48h without observing any visual damage to the foils.

Last minute changes

Location:

It was decided that the tilted foil system should be moved from the beam diagnostics box in REX XL20 beam line to the beam diagnostics box (of the same type) in REX XL65 beam line, just in front of Miniball.

This move was successfully performed with the help from BE/BI (Beam Diagnostics) and BE/ABP (Alignment).

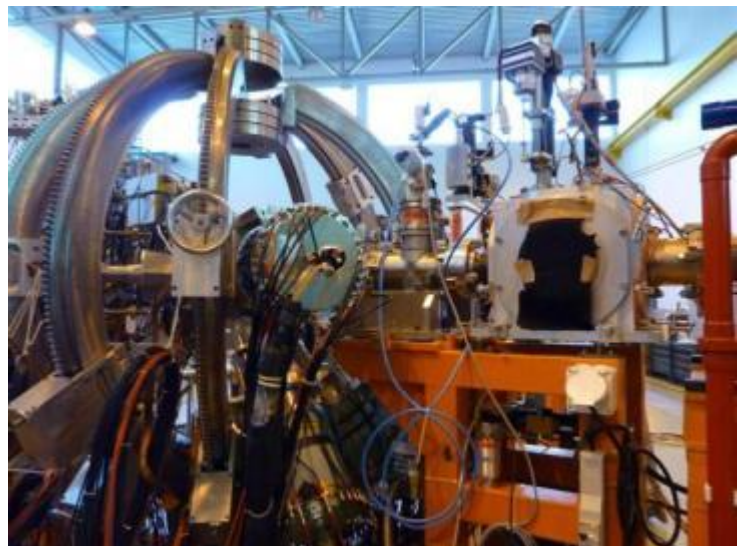

Foils:

A larger width for the polarization foils was used. Two foil types, with 30 and 40 mm widths, were ordered. This was done in order to reach a larger polarization angle ($\pm 75^\circ$) while using multiple foils.

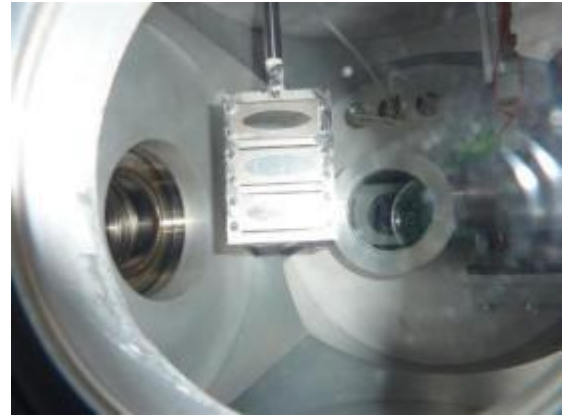

Foil holder:

A new, wider foil holder was manufactured to compensate for the increased width of the foils. Vertical size and center for the three foil positions remained unchanged.

Alignment:

With the move of the foil system to the BD-box in the XL65 beam line, a vertical adjustment of +1mm was required.

The new positions were found to be:

- 95.5 (upper position; **H1**, lower foil)
- 69 (middle position; **H2**, middle foil)
- 42.5 (lower position; **H3**, upper foil)



Position	Y en mm.
H1	0.3
H2	0.2
H3	0.2

The transverse positioning, Y, of H1-H3 was also found to be off-center by 0.2-0.3mm depending on foil position. The precision of the measurement was 0.5mm and therefore it was decided to leave the system as found.

The full alignment report can be found in EDMS doc:
<https://edms.cern.ch/document/1052489>