

CERN LIBRARIES, GENEVA

9.4.1965



CM-P00073682

STOPPING K^- MESON EXPOSURES 5th - 8th APRIL 1965.

A. Conway, D. Evans, E. Dahl-Jensen, D.A. Garbutt, C. Mayeur, A. Montwill,
M.A. Roberts, W.T. Toner.

1. Beam references

The beam used for these exposures (k_4) was designed and set up by a group from the T.C. division at CERN under A. Minten. Preliminary design ideas are discussed in CERN/TC/BEAM 63-2, by A. Minten and G. Petrucci. The performance of the beam and the results of some flux measurements are described in CERN 65-2 (Yellow Report) by J. Duboc, A. Minten and S.G. Wojcicki. Copies of this report can be obtained from the Library.

A. Minten helped us to set up the beam for the exposure.

In any publications, the Yellow Report 65-2 could be quoted. The assistance of Minten should be acknowledged.

2. Differences in beam

The beam described in 65-2 uses a 6-metre separator in the second stage. Our run was made in a shortened version of the beam which used a 3-metre separator, and in which the lenses Q6, Q7 and the second mass slit were all moved about 3 metres closer to the target. In the shortened version, the distance of the mass slit from the target was 24.9 metres. The centre of the stack was 1.1 metres from the mass slit. The shortened version of the beam as used by us is shown in Fig. 1.

3. Layout of emulsion exposures

The layout of mass slit, collimator, degrader and stack is shown in Fig. 2. A magnetized mass slit was used to sweep out particles above and below the K-meson image. The effect of this can be seen in the separator curves shown in Fig. 3. It is impossible to say whether this slit is an improvement over a non-magnetized slit with Tungsten facings, without making further measurements. Fig. 3 can be compared with Fig. 5 of CERN 65-2, if allowance is made for the fact that K^+ are three times more abundant than K^- .

4. Momentum of K^- beam

The maximum number of stopped K^- per pulse is obtained with the beam tuned to 800 MeV/c. However, with the beam tuned to 700 MeV/c, the number of stopped K^- is only reduced by about 20%. At the lower momentum, the separation is more for the same field in the separator. Less degrader is required and therefore the background generated in the degrader by the K^- themselves should be less. Range straggling is also less.

It was therefore decided to run the beam at 700 MeV/c.

5. Beam purity

The beam composition can be estimated from Fig. 3 to be 65% K^- , 35% $\pi^- + \mu^-$. The background particles should be predominantly μ^- mesons. Fig. 5 of CERN 65-2 would show a K^- content of 65% at 800 MeV/c.

6. Intensities

From 65-2, the expected flux of K^- was about $17 \text{ per } 10^{11}$ circulating protons, i.e. $K^- + \text{background}$ would be about $26 \text{ particles}/10^{11}$.

The counters in the beam showed $22/10^{11}$. Test plates exposed in front of the degrader gave about $34/10^{11}$. If it is remembered that counter efficiencies in fast coincidence circuits are likely to be less than 100%, and that test plates always see more particles than even an efficient counter (non-beam particles), it is not unreasonable to assume that the flux is that expected on the basis of 65-2.

Thus $17 K^-$ per 10^{11} , i.e. 77% of the total counting rate.

The time available was such that it seemed reasonable to irradiate each of 4 "East" shots to $1.15 \times 10^6 K^-$ at 700 MeV/c and each of 6 "West" shots to $1.54 \times 10^6 K^-$ at 700 MeV/c. This would give a total of $13.8 \times 10^6 K^-$ before degrading, or about 2.4×10^6 stopped K^- . A reserve of about one shift was left to the end, in case of break-downs. This was used to continue the irradiation, as the other machine users could not be ready at short notice to take over when we had finished. Fig. 4 shows the distribution and intensity of the shots. The numbers are approximate number of stopped K^- mesons expected in units of $\times 10^5$. The total number of stopped K^- is estimated to be 3×10^6 .

7. Size of region in which K^- stop

Along the beam, $\Delta p/p$ and range straggling give an RMS depth of about ± 1 cm.

The area perpendicular to the beam for each shot is expected to be between 10 cm^2 and 30 cm^2 .

8. Geometry of stack and stack holder. Gridding. Thickness.

The stack and its holder are sketched in Fig. 5. Four separately milled sub-stack were assembled in the holder and clamped. After several days three slots were milled to enable the pellicles to be located accurately on the grid. The standard CERN grid was used. The markings on the pellicles are shown in Fig. 6. Table 1 gives the thickness and weight of each pellicle*.

9. Processing

Two thirds of the stack, starting at pellicle No 1, processed at CERN. The last third sent to East Berlin for processing.

10. Use of machine time

We used about 1 shift for setting up and 10.5 for the irradiation. For most of the time we were sole users of the machine. The momentum of the internal beam was 19.2 GeV/c. The repetition rate was 1.6 secs. and the flat-top 20 msec.

* One copy will be sent to each laboratory.

Fig 1

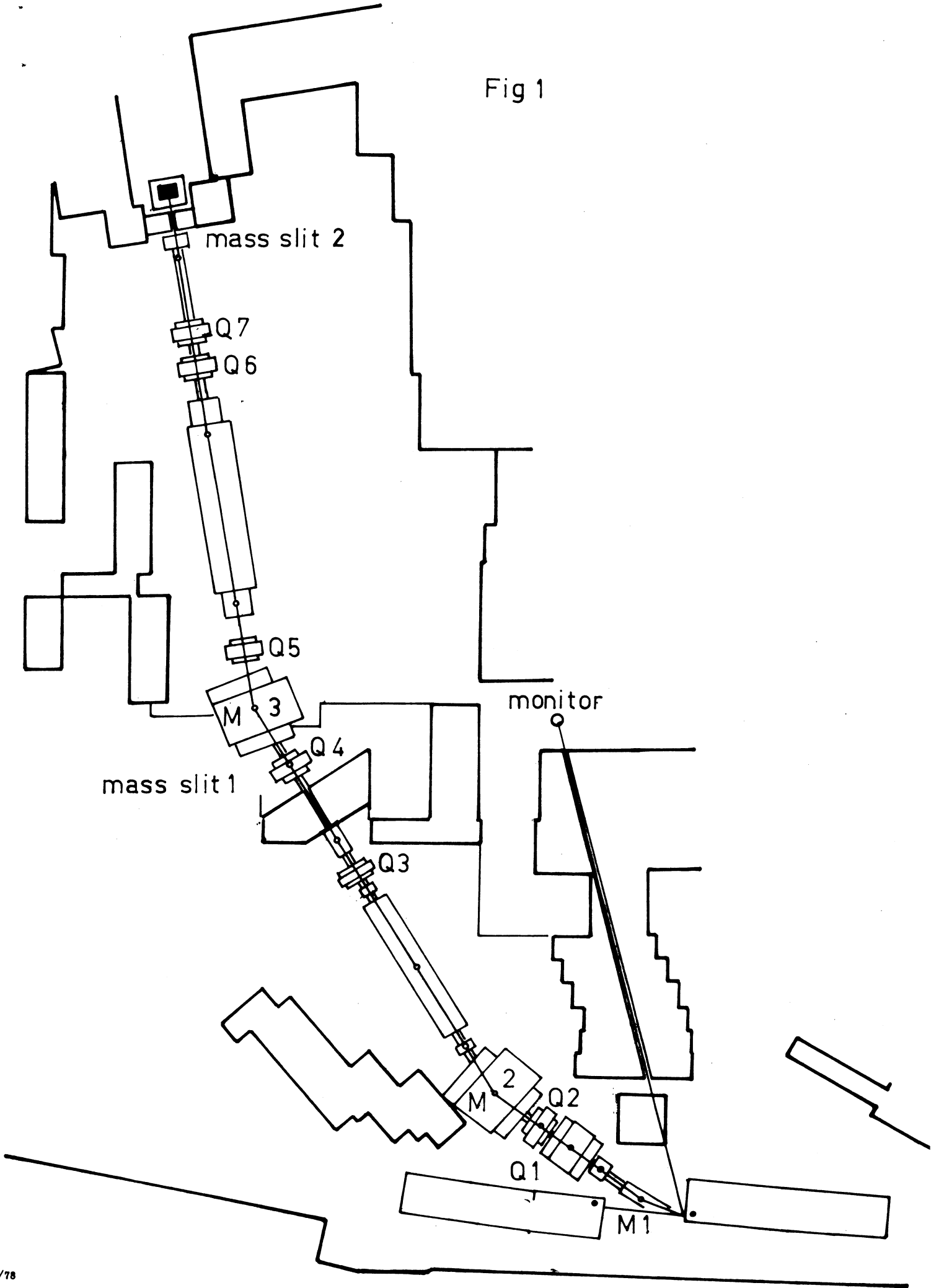

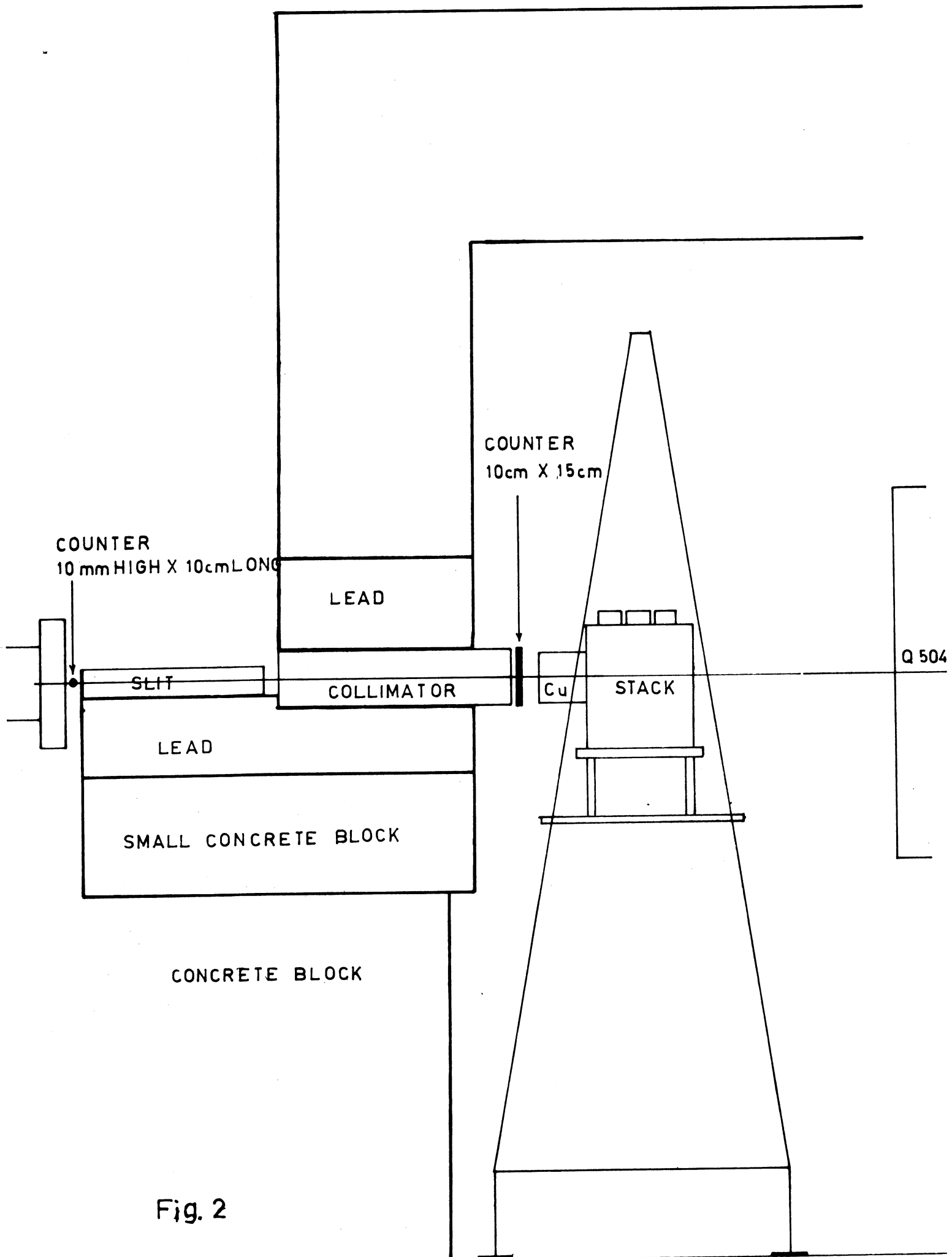

Fig. 2

Fig 3

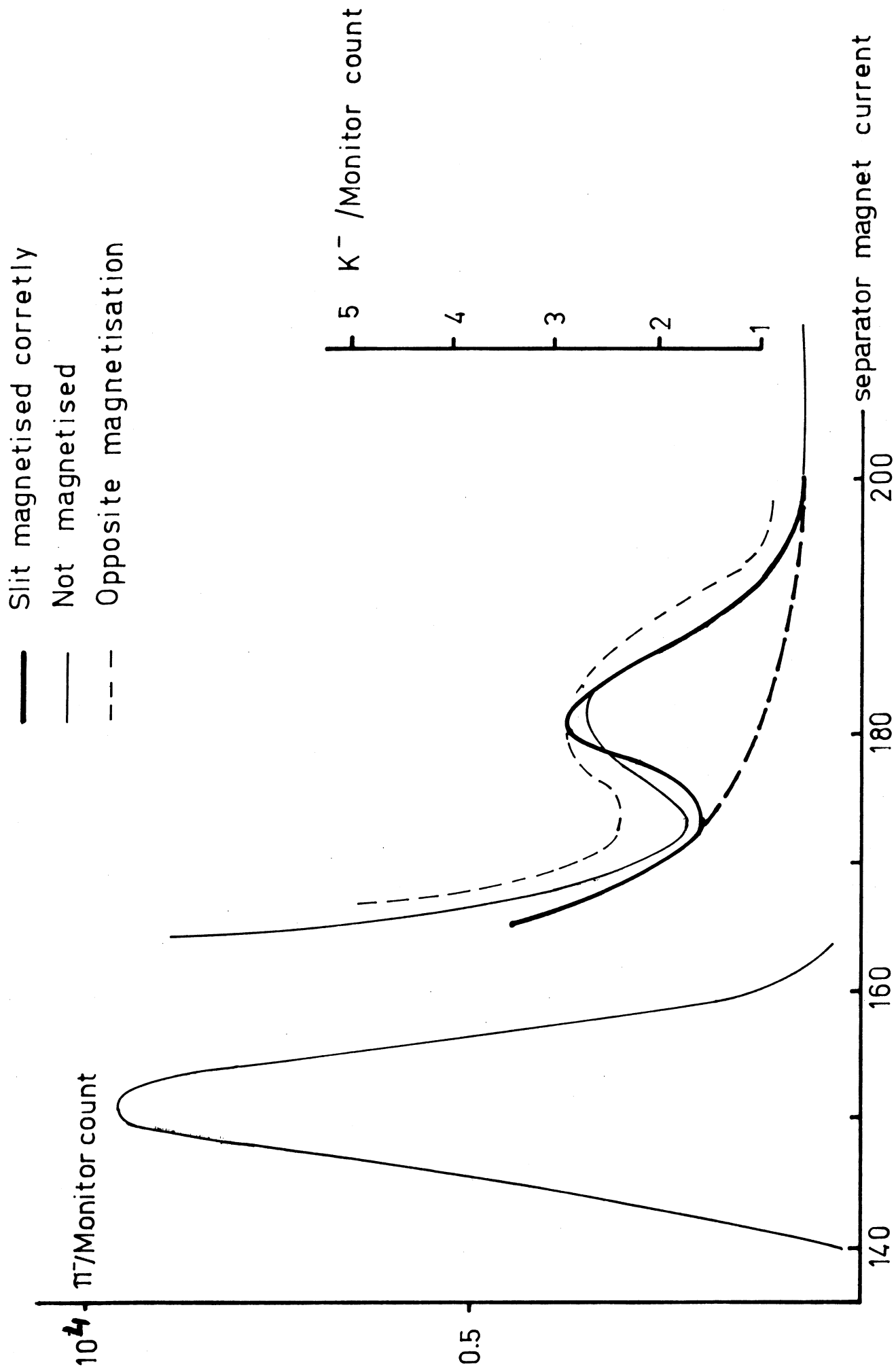
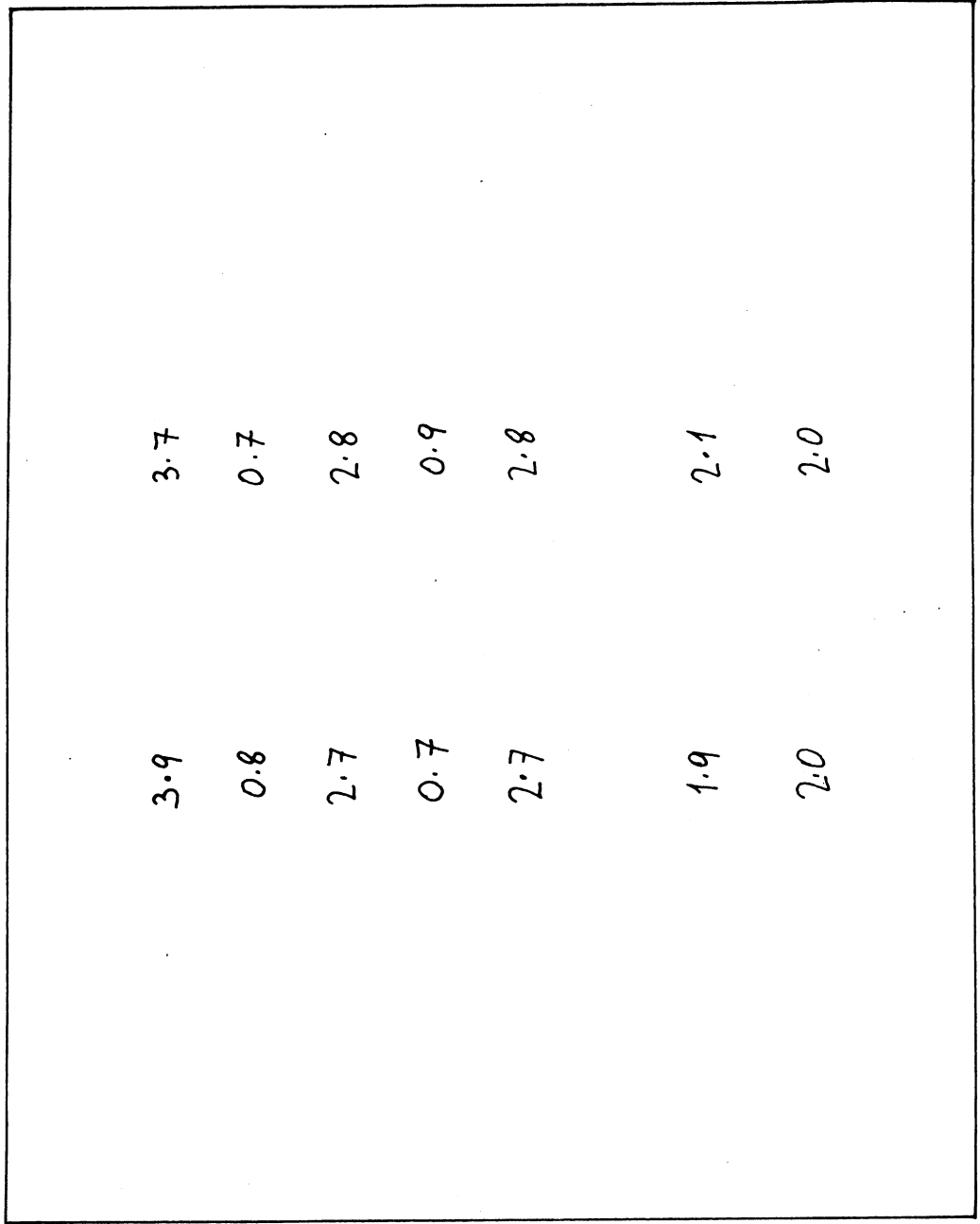
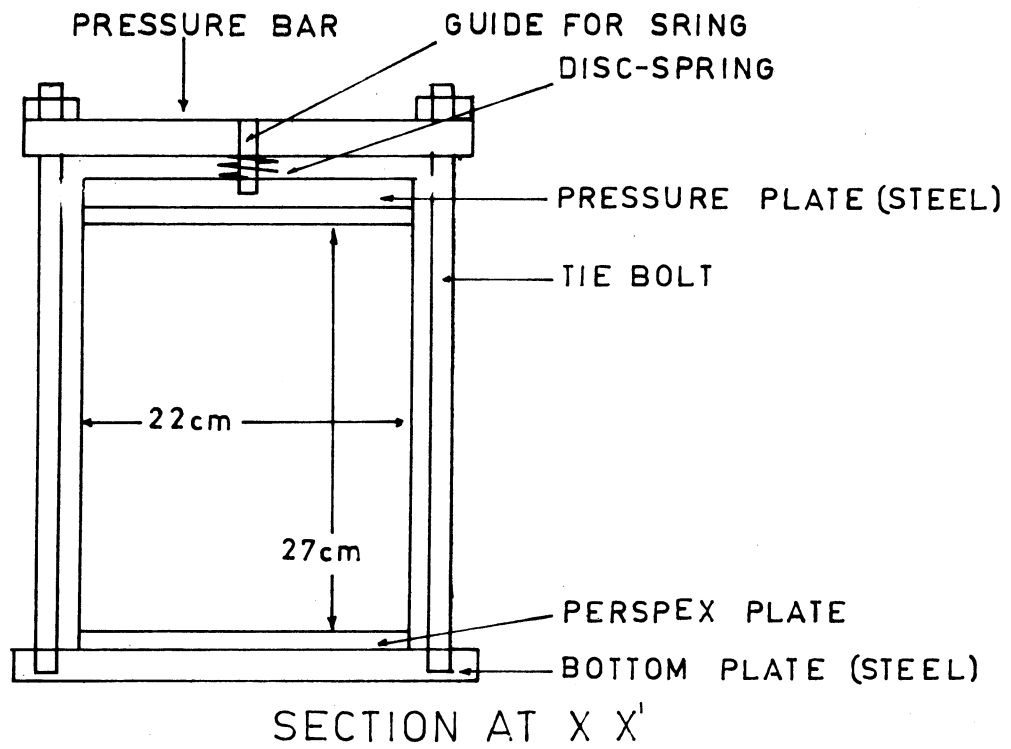
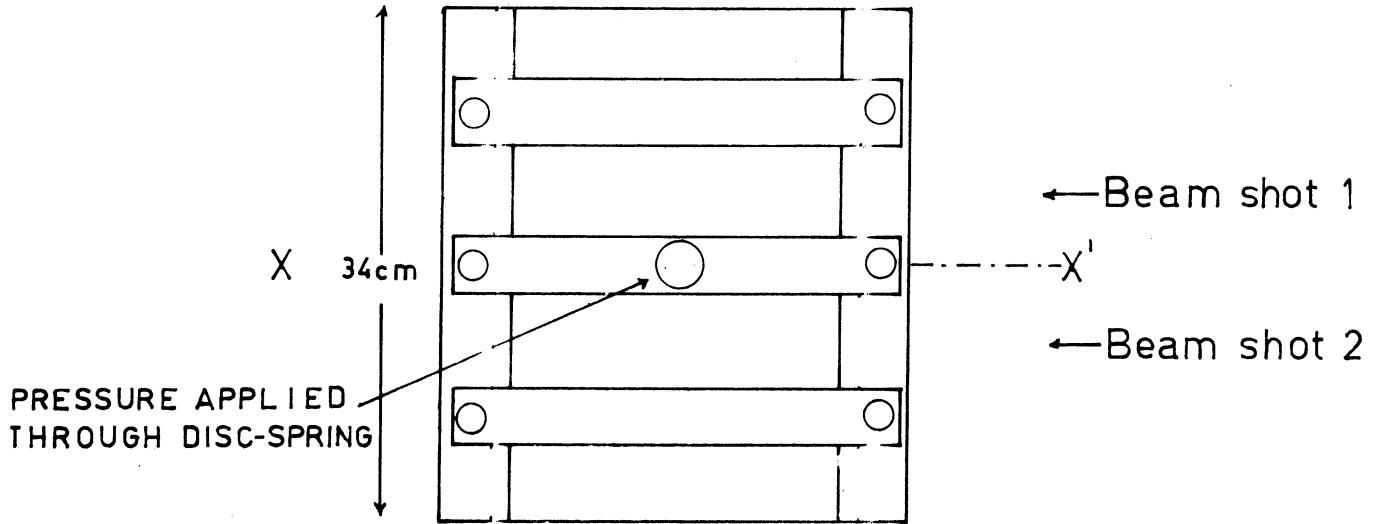

Fig 4
Distribution of Shots in Stack

0 5 10 cms



PLAN VIEW



SKETCH DIAGRAM OF STACKHOLDER

Fig. 5

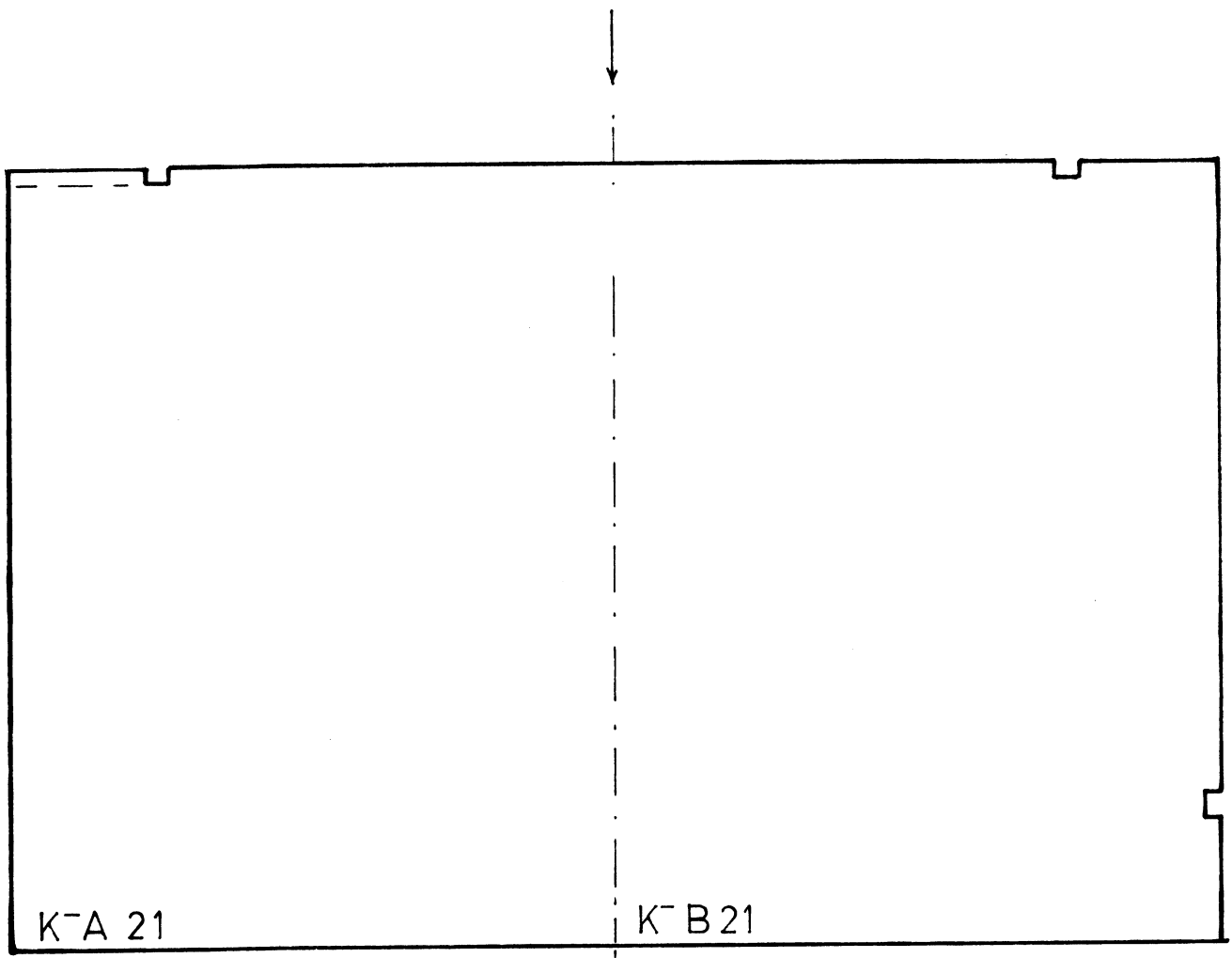

10mm: 20mm

Fig 6 Marking on pellicles