

MPS/Int. DL 64 - 21  
15 September 1964

INVESTIGATIONS WITH THE USE OF ELECTROMAGNETIC

AND ELECTROSTATIC BEAM MONITORS IN THE SLOW

EJECTED BEAM OF THE CPS.

H. Zulliger

Distribution : (open)

Scientific and Technical Staff of MPS Division

PS/4558

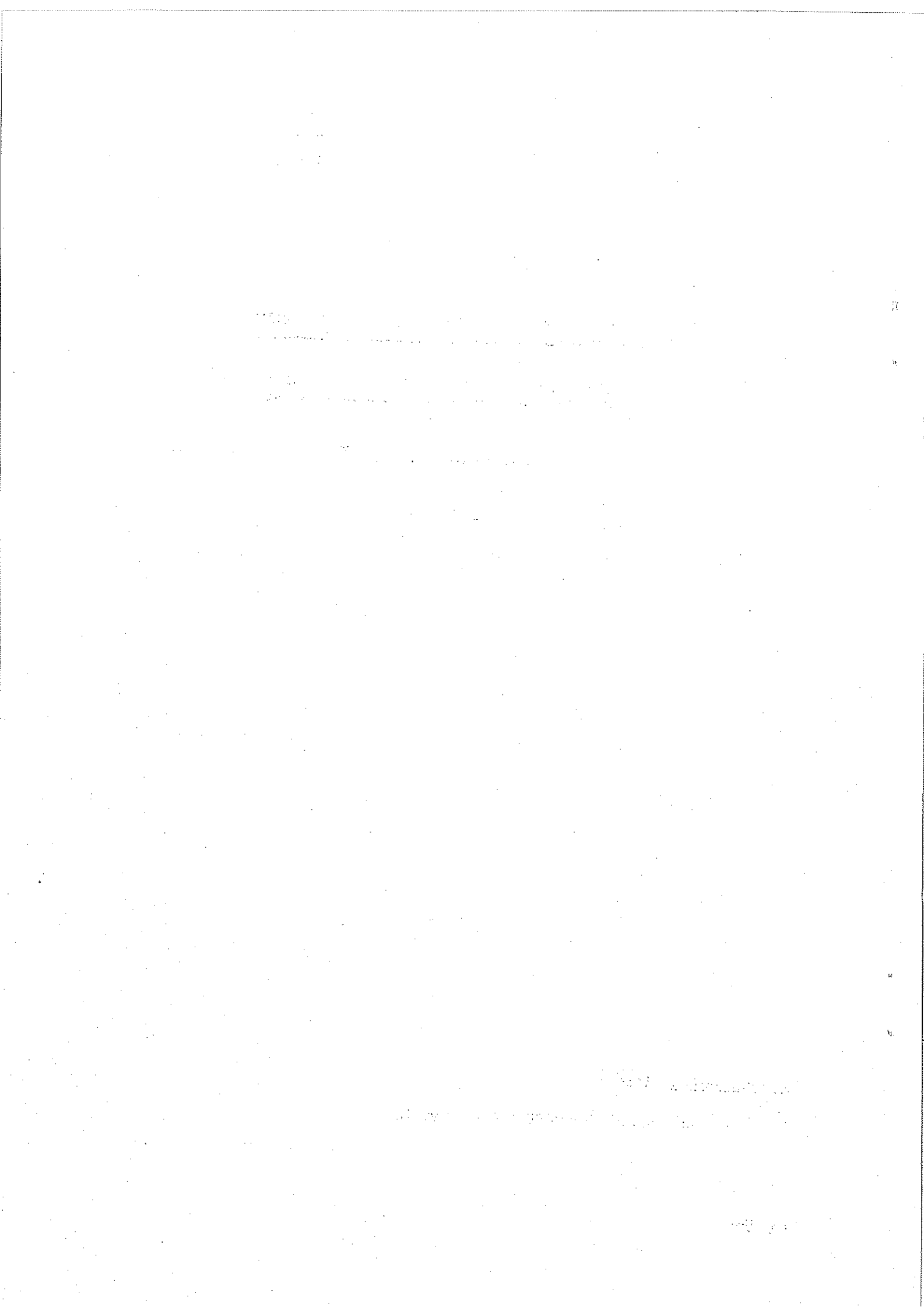

## TABLE OF CONTENTS

	Page
SUMMARY	1
INTRODUCTION	2
PROPERTIES OF THE SLOW EJECTED BEAM	2
<u>PART A - Electromagnetic Beam Monitor</u>	
I. Principle of Operation	3
II. Choice of Values	6
III. Sources of Noise	10
IV. Discussion	17
Appendix I - Magnetic Flux in Toroid	19
II - Magnetic Shield	21
III - Calculation of Inductivity	22
<u>PART B - Electrostatic Beam Monitor</u>	
I. Principle of Operation	23
II. Choice of Values	23
III. Sources of Noise	26
IV. Discussion	27
<u>PART C - Comparison of Electrostatic and Electromagnetic Beam Monitors</u>	28
ACKNOWLEDGEMENT	29
REFERENCES	30

MEMORANDUM

FOR THE RECORD

On 10/10/54, the following information was received from the [redacted] regarding the [redacted] of [redacted] in [redacted] on [redacted] 1954.

The [redacted] of [redacted] was [redacted] by [redacted] on [redacted] 1954. The [redacted] was [redacted] by [redacted] on [redacted] 1954. The [redacted] was [redacted] by [redacted] on [redacted] 1954.

The [redacted] of [redacted] was [redacted] by [redacted] on [redacted] 1954. The [redacted] was [redacted] by [redacted] on [redacted] 1954. The [redacted] was [redacted] by [redacted] on [redacted] 1954.

The [redacted] of [redacted] was [redacted] by [redacted] on [redacted] 1954.

The [redacted] of [redacted] was [redacted] by [redacted] on [redacted] 1954. The [redacted] was [redacted] by [redacted] on [redacted] 1954.

The [redacted] of [redacted] was [redacted] by [redacted] on [redacted] 1954. The [redacted] was [redacted] by [redacted] on [redacted] 1954.

The [redacted] of [redacted] was [redacted] by [redacted] on [redacted] 1954. The [redacted] was [redacted] by [redacted] on [redacted] 1954.

The [redacted] of [redacted] was [redacted] by [redacted] on [redacted] 1954. The [redacted] was [redacted] by [redacted] on [redacted] 1954.

## S U M M A R Y

An electrostatic and an electromagnetic beam monitor are discussed to be used in the slowly ejected beam. The necessary increase of sensitivity of a factor of  $10^5$ , compared to the present system, causes difficulties in amplification and pick-up of external noise sources.

The electromagnetic monitor (Hereward transformer) scales up the sensitivity by increasing the number of secondary turns and improving the geometry and permeability of the system. The output voltage for 0.25  $\mu$ a beam current of the transformer considered would be 7.5  $\mu$ v and the current  $5 \times 10^{-11}$  A, both values are too small compared with the input noise of good commercial amplifiers. Fourteen different external noise sources are discussed. The disturbance from the PS magnet (at straight section 60) is about 100 times larger than the flux induced by the beam and extensive magnetic shielding would be necessary.

A long electrode (e.g. 1 m) for the electrostatic pick-up monitor increases the sensitivity but the output signal is still only 37  $\mu$ v, with an initial current of  $1.3 \times 10^{-15}$  A. Good electrometer tubes have leakage currents in the same order of magnitude and only a special tube or field effect transistors could solve this problem. From the external noise sources, the ionization of the residual gas causes one of the more severe disturbances. A grid is suggested to collect these free charges.

We conclude that the discussed types of electromagnetic and electrostatic beam monitors can only be used if we are able to develop suitable amplifiers and reduce all the external noise sources below the signal strength from the beam. A **step-by-step** increase of sensitivity is suggested in order to find the superiority of either the electromagnetic or electrostatic detector.

I N T R O D U C T I O N

The property of being non intersecting makes the use of electromagnetic and electrostatic pick-up stations very attractive. The purpose of this report is to investigate modifications of the presently used monitors to make them suitable for the slowly ejected beam. The numbers given should be considered only as figures of merit with the purpose of pointing out the problems envolved in these projects.

PROPERTIES OF THE SLOWLY EJECTED BEAM

The slowly ejected beam consists of bursts of variable lengths, namely from 0.5 msec up to about 200 msec. This causes the current to be reduced proportionally from 100  $\mu$ a to 0.25  $\mu$ a for  $3 \times 10^{11}$  protons/p. Table I shows some typical values of the slowly ejected beam.

Type ejected beam intensity	$3 \times 10^{11}$ p/burst	}
Pulse duration	0.5 to 200 msec	
Proton flux	$6 \times 10^{14}$ to $1.5 \times 10^{12}$ p/sec	
Repetition rate	every 1 - 3 sec	
Current (typical)	100 $\mu$ a (at 0.5 msec pulse length)	
	0.25 $\mu$ a (at 200 msec pulse length)	}

TABLE I

PART A : ELECTROMAGNETIC BEAM MONITOR

I. Principle of Operation

We first consider the principle as suggested by Hereward (Fig. 1) of a tertiary feedback winding. This eliminates the influence of the winding resistance. Note that this system works only well for low frequencies, since a phase shift in the feed back loop can cause instability.

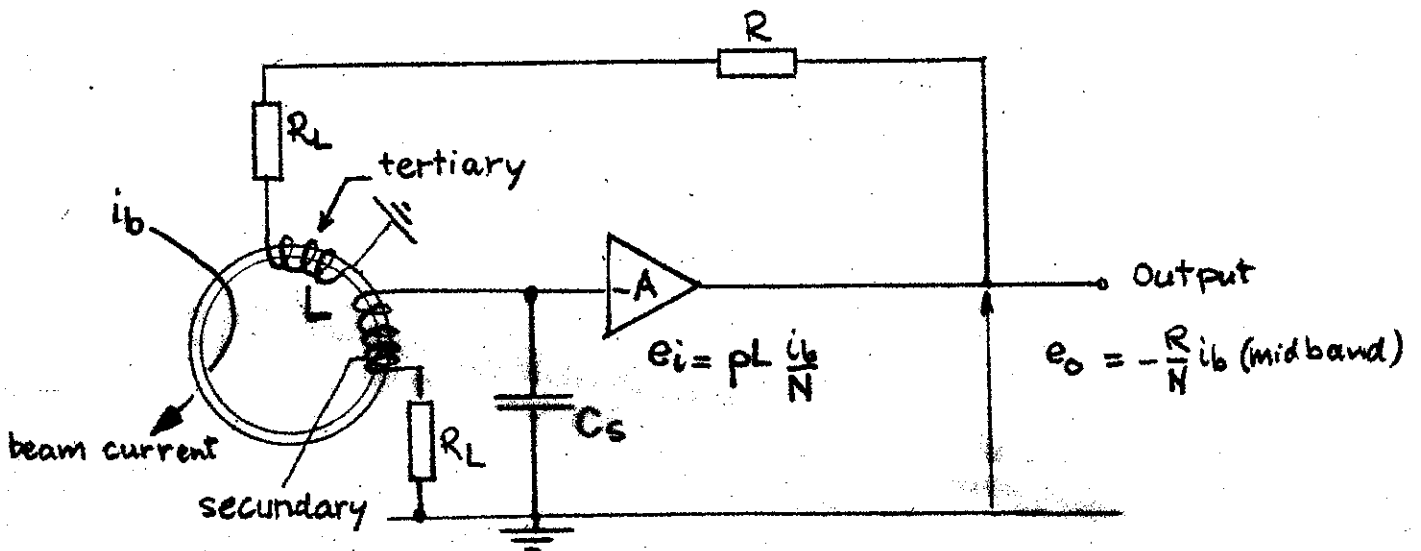

Principle of Hereward Transformer

The transfer function is (Fig.1) :

$$\frac{e_o}{i_b} = - \frac{R}{N} \frac{1}{\frac{1}{pA \frac{L}{R}} + p \frac{CsR}{A} + 1 + \frac{1}{A}} \quad (1)$$

if  $A \gg 1$ , we obtain

$$\frac{e_o}{i_b} = - \frac{R}{N} \frac{1}{\frac{1}{pA \frac{L}{R}} + p \frac{CsR}{A} + 1} \quad (2)$$

at low frequencies  $t \rightarrow \infty$  } and the  
 $p \rightarrow 0$  }

transfer function becomes :

$$\frac{e_o}{i_b} = - \frac{R}{N} \frac{pA \frac{L}{R}}{1 + pA \frac{L}{R}} \quad (3)$$

for high frequencies  $t \rightarrow 0$  } and  
 $p \rightarrow \infty$  }

$$\frac{e_o}{i_b} = - \frac{R}{N} \frac{1}{1 + \frac{pCsR}{A}} \quad (4)$$



at mid band

$$\frac{e_o}{i_b} = - \frac{R}{N}$$

(5)

$e_o$  = Output voltage

$i_b$  = Beam current

$R$  = Feed back resistor

$N$  = Number of turns

$p$  = Laplace variable

$A$  = Amplifier gain

$L$  = Inductance of toroid

$C_s$  = Stray capacity

$R_L$  = Winding resistance

## II. Choice of Values

We can choose the following parameters :

- R Feed back resistor
- N Number of turns
- A Amplifier gain
- L Induction of toroid
- C<sub>s</sub> Stray capacity

The feed back resistor is determined by the drive current available at the output of the amplifier to give a reasonable scale factor. If a postamplifier is considered the smallest current should produce a signal above the noise level. From equation (3) (Fig.1) follows :

$$R = \frac{e_o}{i_b} N$$

Assuming a low noise stabilized transistor amplifier, e.g. Philbrick SP 656, we find the voltage noise 10  $\mu$ v p.p. If we assume  $e_o$  at least 50  $\mu$ v at  $i_b = 0.25 \mu$ a and  $N = 5000$ , then

$$R = \frac{50 \mu\text{v}}{0.25 \mu\text{a}} \cdot 5000 = \underline{\underline{1 \text{ M } \Omega}}$$

From Fig. 1 we derive the input voltage

$$e_i = pL \frac{i_b}{N}$$

and realize that we can write  $L = KN^2$ .  $K$  is a factor of the toroid containing geometry, permeability etc.

We substitute L and assume a step input ( $\frac{1}{p}$ ):

$$e_i = KN i_b.$$

In order to develop a sufficient input voltage we have to make K and N high. If we choose 10 toroids of "Ultraperm 10" (App.III) as shown in Fig. 2 we get  $K = 1.4 \times 10^{-3}$  h. N is limited by the stray capacity of the windings and has to be found experimentally. For the moment we consider 5000 and 25000 turns.

The input voltage becomes then :

	N = 5000	N = 25000
$e_i = 1.4 \times 10^{-3} \text{ h} \times 0.25 \text{ } \mu\text{a} \times N =$	1.5 $\mu\text{v}$	7.5 $\mu\text{v}$

The input current :

$i_{in} = \frac{i_b}{N} = \frac{0.25 \text{ } \mu\text{a}}{N} =$	5 x 10 <sup>-11</sup> a	10 <sup>-11</sup> a
--	-------------------------	---------------------

The equivalent drift (Fig.1)

$i_{bequ} = e_d \frac{N}{L} = \frac{e_d}{KN} =$	0.017 $\mu\text{a}$	0.085 $\mu\text{a}$
---	---------------------	---------------------

$i_{bequ}$  = equivalent drift current

$e_d$  = drift voltage

The time constants can be written as follows (Fig.1) :

$$T_1 = \frac{L}{R} A = \frac{3.6 \times 10^4}{10^6} \cdot 2 \times 10^8 = 7.2 \times 10^6 \text{ s} \quad \begin{matrix} 5000 + \\ 25000 + \end{matrix} \quad \begin{matrix} 1.8 \times 10^8 \text{ s} \end{matrix}$$

$$T_2 = \frac{C_s R}{A}, \quad \text{chosen to be} \quad \leq 50 \text{ } \mu\text{sec}$$

$C_s$  is not known and difficult to calculate.  $A$  is frequency dependent which is a characteristic of the chosen amplifier. Since the long time constant  $T_1$  is sufficient for both possibilities of 5000 and 25000 turns, we choose a final number of turns giving us together with the amplifier a time constant  $T_2 \approx 50 \mu\text{sec}$ . This is possible if the total capacity  $C_s \leq 0.1 \mu\text{f}$  and an amplification  $A$  at  $50 \mu\text{sec}$  is  $\geq 2000$ .

The noise considerations are guided by the present status of amplifier techniques. One of the best commercially available low noise amplifier is the Philbrick SP 656. This chopper stabilized silicon transistor amplifier has the following properties :

dc open loop gain	$2 \times 10^8$
Small signal unity gain band width	1 Mc
Input voltage offset (per $\frac{1}{2}$ hour)	1 $\mu\text{v}$
Narrow band noise (p.p. voltage)	10 $\mu\text{v}$
Input current offset (per $\frac{1}{2}$ hour)	$10^{-11}$ amp
Narrow band noise (p.p. current)	$10^{-10}$ amp

Comparing this data with the input voltage  $e_i$  and the current  $i_{in}$  we find that both of them are well within the noise band. Note, that increasing the number of turns improves the voltage signal but at same time reduces the current proportionally.

A number of low noise amplifiers have been developed, among them one by Radekka 10/. The T I 2 N 930 Transistors also look promising for low noise amplifier design. Unless an amplifier can be found commercially available much better than the Philbrick SP 656, we have to develop our own model.

Experience with the present beam monitor has shown that there are a number of other external noise sources present which exceed by far the amplifier noise. It is the purpose of the following section to investigate these sources of noise.

### III. Sources of Noise

We consider the following possible sources of noise :

1. RF from Linac
2. RF from accelerator
3. DC magnetic fields
4. Ripple from magnetic fields
5. Fields from mains
6. Stray protons
7. Flat top slope
8. Accelerator noise
9. Noise due to inhomogenities in toroid
10. Earth magnetic field
11. Noise from pulsed machines
12. Radiation damage
13. Microphonic noise
14. Electrostatic pick-up

#### 1. . 2. RF from Linac and Accelerator

Linac RF	202.6 MHz	4/
Acc RF	2.9 - 9.55 MHz	

These frequencies are beyond the sensitive range of our toroid and can be filtered out very easily. We also mount the system insulated from the beam pipe, such that gravelling waves pass the toroid outside and thus do not interfere with the electronics.



Fig. 4 shows the position of the toroid and the flux gradient  $\frac{\partial \vec{B}}{\partial \vec{r}}$  at that point is  $0.1 \text{ Wb/m}^3$ .

We now have to calculate the induction of the toroid. This is very difficult to do with precision, but a geometrical approximation will give us the order of magnitude. Fig. 6 explains the procedure and yields the result of  $\sim 75 \text{ Gs}$  induced by one section of the PS magnet. The voltage ripple filtered is  $0.5 \%$  of  $5.4 \text{ kV}$ . According to measurements by M. Georgijevic <sup>5/</sup> the induction changes about  $3.5 \text{ Gs}$  in the air gap. This value reduced by  $\frac{75}{12000} = 6.25 \times 10^{-3}$  (Fig. 6), due to the toroid position, yields :

$$\Delta \vec{B}_s = 3.5 \text{ Gs} \times 6.25 \times 10^{-3} = \underline{2.2 \cdot 10^{-2} \text{ Gs}}$$

Appendix I shows that the flux in the toroid under normal conditions (pulse length  $200 \text{ msec}$ ,  $0.25 \mu\text{a}$ ) will have an induction of about  $5.5 \times 10^{-2} \text{ Gs}$ . If we desire to measure to  $10\%$  accuracy we can tolerate an induction of  $5.5 \times 10^{-3} \text{ Gs}$ . This value is already in the order of magnitude of our stray field. Considering the many crude approximations and assumption along the calculations, we suggest nevertheless a shield of Mu-metal (1,1,1) <sup>7/</sup> App II which reduces the stray field by a factor of  $\sim 400$ .

### 5. Fields from Mains

There are two noise sources from the mains

- a) Stray fields from  $50 \text{ cycles a.c.}$
- b) pick-up through pulsed machines viamains.



to a) Long cables with high currents in the neighbourhood of the toroid produce intensive disturbance of low power signals. The hum enters either through electric coupling directly with the toroid or induces noise in the cables to the amplifier and in the electronics itself. The electric field can be shielded by enclosing the toroid with a copper sheet and using double shielded microphone cable as leads to the amplifier. Also the amplifier should be shielded.

to b) The influence of pulsed equipment, e.g. spark chambers etc. can enter the electronics through the mains. The system can effectively be decoupled by using a voltage stabilizer to feed the power supply. It is important to keep these cables short.

terminal  
Since the distance between pick-up and read-out/is very long the grounding is very important. The ground potential can differ several volts between these two points. The best performance with the beam monitor at Stanford's Linac M III was obtained with double shielded coax cables, floating at the pick-up station and one single solid ground at the read out point.

This is also suggested to apply here.

Noise from the mains can be avoided to a great extent by careful layout and shielding.

## 6. Stray Protons

There are about  $10^3$  times less protons at the beam tube wall than in the centre of the tube. Assuming all these protons hit the wall and produce about 3 times more secondary electrons, the current inside the toroid is still about 300 times larger than outside. The current produced by stray protons and secondary electrons is therefore negligible. There will be some heat production in the toroid by the stray protons which, however, will be mostly compensated by the tertiary feed back winding. (Electrostatic pick-up on page 16).

7. Flat Top Slope

During the slow ejection the "flat top" of the magnet pulse has a slope. At about 18 Gey we require a slope of  $\int_c \dot{B} dt = 108 \text{ Gs } \frac{8}{\text{V}}$ . As a result  $\frac{\partial}{\partial t} \left( \frac{\partial B}{\partial r} \right) = 0$  and thus a net current will be induced in the toroid.

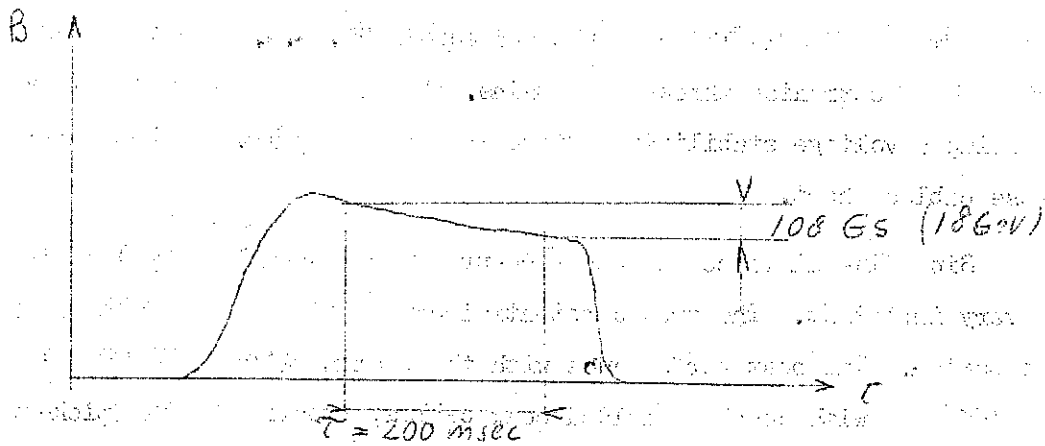

Fig. 1 Pulsed Magnet

At position 3 (straight section 60) we obtain again a reduction of the induction in the toroid, namely :

$$\vec{B}_s = 108 \text{ Gs} \times 6.25 \times 10^{-3} = \underline{0.675 \text{ Gs}}$$

This value compares with 0.055 Gs induction from the beam pulse (200 msec pulse length). A shield of more than a factor of 100 is necessary. In order to be on the safe side I suggest a double layer Mu-metal M 1040 App II carefully welded and mounted (Fig. 2).

### 8. Accelerator Noise

The circulating beam contains components of the revolution frequency, 150 to 450 kHz and its harmonics. This is at the low end of the proposed RF filter. It would be desirable to reduce the band width of the circuit by using a filter to keep these frequencies out. The exact cut-off point can be easily determined in practice. A cut-off at 100 kc seems to be a reasonable order of magnitude.

### 9. Noise Due to Inhomogenities in the Construction of the Toroid.

Present measurements II have shown differences in results by turning the toroid around its axis. This experiment <sup>us to</sup> allows conclude that inhomogenities must be present. The exact origin could not yet be determined but the following reasons are considered :

- a) inhomogenities in magnetic material
- b) uneven distribution of the windings
- c) inhomogeneous magnetic shield
- d) pick-up by feed through and leads

All these points are of great importance for our highly sensitive device. Special care should be taken for the magnetic shield. We have assumed that a constant gradient field has no net flux in the toroid, but an inhomogeneity in the shield nullifies this statement. Any welding joint or feed through is the origin of asymmetry and thus of noise. It is my opinion that careful shielding is the key to the success of this beam monitor.

### 10. Earth is magnetic field

The earth <sup>is</sup> magnetic field is practically constant and almost homogeneous and can therefore be neglected.

### 11. Noise from Pulsed equipment

One of the noisiest pulsed equipment is the spark chamber. As we discussed earlier, the pulse can travel through the mains. In addition every spark creates a continuous spectrum of electro-magnetic waves which propagates through the air and along the beam pipe etc. An electric decoupling from the beam pipe is necessary (also from the point of view of accelerator noise) and an effective HF shield. Here again the earlier discussed copper sheet metal will reduce the noise (Fig. 2).

### 12. Radiation Damage

Previous experience has shown that magnetic material is not appreciably affected by radiation and we can assume that this will also be the case for the material presently in use.

Reference 9/ gives information on tests of electronic equipment in radiation. Most transistors show loss of gain after exposure to several krad radiation. All tested circuits worked up to 100 krad which corresponds to about 100 hrs near the internal target. In the ring we may expect a multiple of 100 hours. It has been suggested by 11/ to mount the amplifier in a hole in the floor below a magnet. This could provide some shielding and the life of a transistorized amplifier could well exceed a tube circuit.

### 13. Microphonic Noise

Due to mechanical vibration the system can act like a microphone 11/. This requires a mounting on shock absorbers between beam pipe and monitor. Exact measurements of this microphonic effect are, however, still missing.

### 14. Electrostatic Pick-up

Holcomb et al 13/ claim that the electrostatic pick-up of the magnetic coil can exceed the magnetic induced signal. It is obvious that also the toroid has a capacity to the beam and to the case, as well as a high winding capacity. Holcomb suggests an electrostatic shield which collects free charged particles (Fig. 2).

#### IV. Discussion

With the presently available commercial amplifier we could measure with the **circuit described** beam currents as low as about  $1.2 \mu\text{a}$  which corresponds to a beam pulse length of about 400 msec, neglecting all external noise. Only if the input noise level of the amplifier can be reduced by at least a factor of 5 we reach the limit of  $0.25 \mu\text{a}$  and 200 msec. With the **components available at present** it seems possible to reach this value, but extensive development will be necessary. The external sources of noise will also cause considerable problems and only with extreme care and some experiments we can hope to reduce the noise to the level of the amplifier.

Such a current monitor would have the following characteristic :

1. Principle schematic as proposed in Fig. 1 (Hereward transformer)
2. 10 laminated toroids (Ultraperm 10,  $\mu_5 = 120\ 000$ ).  
Dimensions 130 x 90 x 20 (about 100 sfr./kg)
3. 5000 - 25 000 turns, tertiary winding bifilar
4. Amplifier : Philbrick FP 656 (or locally built model)
5. Construction as proposed in Fig. 2
6. Multiple shield with Mu-metal MIO40 with copper layer between plus electrostatic shield
7. We expect to measure as low as  $1.2 \mu\text{a}$  which corresponds to 40 msec pulse length.

Improvements of the presently suggested circuit could be twofold :

- a) Design of low noise and high stability amplifier using cascode input with 2N930 transistors or thin film field effect transistors.

b) Utilize the principle of a tank circuit as presently being developed by V. Radeka<sup>12/</sup> for solid state detectors. The author expects a gain of about 100 which would be sufficient to drive an ordinary amplifier. The analysis of such a circuit is however very difficult and would require a research project by itself.

It is also impractical to lengthen the system much further and the inductivity coefficient  $k$  must be considered for the present a constant.

Before trying to develop new circuits, I suggest evaluating the results from the monitor being now developed for the 0.5 msec slowly ejected pulse.

APPENDIX I

Magnetic Flux in Toroid for Slowly Ejected System

1 turn of  $0.25 \mu\text{a} / 200 \text{ msec}$

$$R_m = \frac{l}{\mu A} = \frac{1}{\Lambda} = \text{magn. resistance}$$
$$= \text{magn. conductance}$$

$$\theta = \frac{\phi}{\Lambda} ; = \text{magn. tension}$$

$$\theta = H \cdot l = f(\vec{r})$$

given :  $l, A, \mu \rightarrow R_m$        $l = 2\pi r = 2\pi \times 11.0 \text{ cm}$   
 $A = (2 \times 2) 10 = 40 \text{ cm}^2$

$$H = \frac{NI}{2\pi r} \quad \text{in toroid}$$

$$r = \frac{130 + 90}{2} = \frac{220}{2} = 110 \text{ mm} = 11.0 \text{ cm}$$

$$I = 0.25 \mu\text{a} \quad (\text{lowest current})$$

$$N_1 = 1 \quad (\text{primary winding of beam})$$

find  $\vec{B}_{\min}$  in Mu-metal

$$\vec{B} = H \mu(H) \quad \text{assume } \mu \text{ being small and thus}$$

$$120'000 \times \mu_0 = \text{constant}$$

$$\mu_0 = 4\pi \times 10^{-5}$$

$$B = \frac{NI \times 4\pi \times 10^{-5} \times 1.2 \times 10^5}{2\pi r}$$

$$B_{\min} = \frac{1 \times 10^{-1} \times 2.5 \times 2 \times 10^{-5} \times 1.2 \times 10^5}{.11} = 5.5 \times 10^{-6} \frac{\text{Wb}}{\text{m}^2}$$

$$B_{\min} \left[ \frac{V_s \times V_s}{m \lambda_m} = \frac{V_s}{m^2} = \frac{\text{Wb}}{\text{m}^2} \right] = \underline{\underline{5.5 \times 10^{-2} \text{ Gs (200 ms)}}$$

$$B_{\max} = \underline{\underline{22 \text{ Gs (.5 msec)}}$$

Assuming an accuracy of about 10% we are required to keep the noise down to 5.5 x 10<sup>-3</sup> Gs.

Calculate the magnetic flux  $\phi$ .

$$\phi = \mathcal{L} \cdot \theta = \frac{\mu A H \cdot \mathcal{L}}{\mathcal{L}} = \mu A \cdot H = \frac{\mu A NI}{2\pi r}$$

$$= \frac{\mu r \times 4\pi \times 10^{-5} \times A NI}{2\pi r}$$

$$\phi = \frac{1.2 \times 10^5 \times 10^{-5} \times 40 \times 10^{-4} \times 2.5 \times 10^{-1}}{.11} = 109 \times 10^{-10} \text{ Vs}$$

$$\left[ \frac{V_s \times A \times \mu^2}{4\pi \times r} = \text{Vs} \right]$$

$$= \underline{\underline{1.09 \times 10^{-8} \text{ Vs}}}$$



APPENDIX II

Magnetic Shield  $\frac{1}{2}$

Good shielding results are obtained with thin multiple layer high permeability material. For low frequencies the Mu-metal M-1040 seems to be best suited.

Permeability at 5mOe = 35 000

$\mu_{\max}$  = 60 000 for bulk

$\mu_{\max}$  = 90 000 for foil

Shielding attenuation factors :

VAC Firmenblatt M 001, Weichmagn.Werkstoffe.

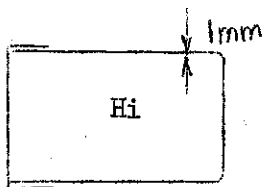

$$RB\ 42 \left( \frac{H_a}{H_i} \right) \approx \underline{400}$$

This is true for very low H (0.5 Oe) only.

Fig. 8

APPENDIX III

Calculation of the Inductivity L of the toroid

From reference 2) we have the following formula :

$$L = 2 N^2 b \left( \log_e \frac{g+a}{g-a} \right) \cdot 10^{-9} \text{ h}$$

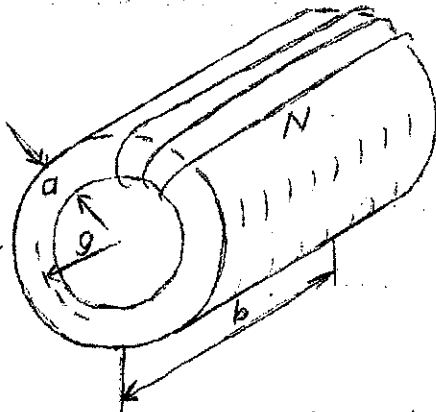

Fig. 9. Coil consisting out of 10 Toroids.

$$N = 5.000 \quad (25.000)$$

$$b = 10 \times 2 = 20 \text{ cm}$$

$$g = 11 \text{ cm}$$

$$a = 2 \text{ cm}$$

$$L = 2 \times (5 \times 10^3)^2 \times 20 \left( \log_e \frac{11+2}{11-2} \right) \cdot 10^{-9}$$

$$= 2 \times 25 \times 10^6 \times 20 \left( \log_e \frac{13}{9} \right) \cdot 10^{-9}$$

$$= 10^9 \cdot 0.365 \times 10^{-9} = 0,4 \text{ h in air.}$$

With a permeability of 120.000 we get 36.000 h.

If we check the previous toroid using the same formula we obtain, using  $\mu_r = 10.000$ ,  $L = 0,27 \text{ h}$  which coincides with 1).

PART B

Electrostatic Beam Monitor

I. Principle of Operation

The measurement of the slow ejected beam requires an increase of sensitivity by a factor of  $10^5$  compared to the presently used monitor for fast ejection. Current development stresses higher bandwidth, which could be sacrificed to obtain the required sensitivity for slow ejection.

Fig.10 shows the geometry of the electrostatic pick-up principle.

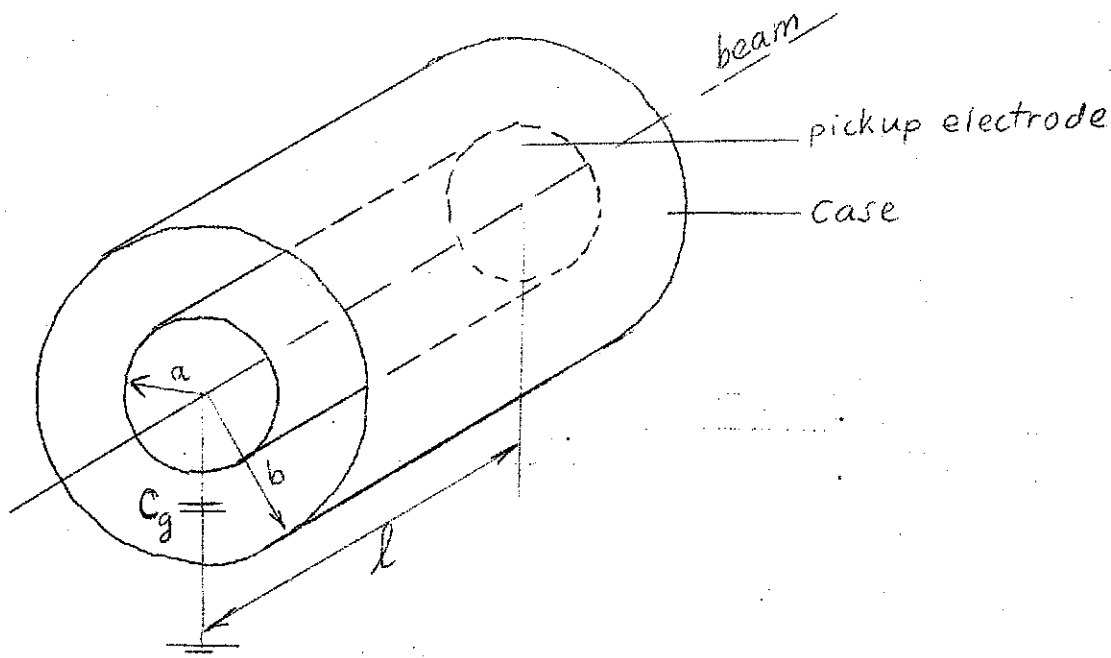

II. Choice of values.

In order to obtain a high output voltage

$$V = \frac{Q}{C_g}$$

V = output voltage

Q = beam charge

C<sub>g</sub> = capacity between electrode and ground

we like Q large and C<sub>g</sub> small.

First we calculate the charge per unit length for the slow ejected beam of 200 msec and 0,25  $\mu$ a .

$$N_l = \frac{N_o}{v \cdot t} \quad \text{and}$$

$$Q_l = N_l \cdot e = \frac{N_o \cdot e}{v \cdot t}$$

$N_l$  = number of particles per unit length

$N_o$  = number of protons per pulse =  $5 \times 10^{11}$  (typical)

$l$  = length of the electrode, = assume 100 cm

$e$  = charge of proton =  $1.6 \times 10^{-19}$  Asec

$v$  = velocity of protons =  $3 \times 10^{10}$  cm/sec

$t$  = pulse length = 200 msec

$Q$  = charge per unit length

$$Q_l = \frac{5 \times 10^{11} \times 1.6 \times 10^{-19}}{3 \times 10^{10} \cdot 0.2} = \frac{1.33 \times 10^{-17} \text{ As}}{\text{cm}}$$

We like  $Q$  big, thus  $l$  long, let us say 100 cm, and obtain:

$$Q_{\min} = Q \cdot l = 1.33 \times 10^{-17} \times 100 = \underline{1.33 \times 10^{-15} \text{ As}}$$

$Q_{\min}$  = Charge on electrodes with the minimum beam current.

A large  $l$  increases proportionally  $C_g$  and we do not gain voltage by making the electrode longer. However, from the current point of view, it is desirable to have a high charge available.

The capacity  $C_g$  can be estimated by the following formula <sup>14/</sup>  
(neglecting end effects):

$$C_g = \frac{0.00736 \times k}{\log_{10} (b/a)} \quad \text{in } \mu\text{f}/1000 \text{ ft.}$$

In order to keep  $C_g$  low we like the electrode diameter  $b$  large and the case diameter  $a$  small.

Assuming

$$b = 40 \text{ cm}$$

$$a = 5 \text{ cm}$$

$$k = 1$$

$$C_g = 27 \text{ ft}$$

including feedthroughs, input capacity of tube, leads etc., we guess about 35 pf.

Thus

$$V_{\min} = \frac{Q_{\min}}{C_g} = \frac{1.3 \times 10^{-15}}{35 \times 10^{-12}} = \underline{37 \mu\text{V}}$$

$V_{\min}$  = voltage across  $C_g$  caused by minimum beam current.

If we desire to measure the total beam current we have to integrate the output signal over the capacity  $C_g$ . For this purpose we need an electrometer tube. An integrating time constant of  $5 \times \tau = 5 \times 200 \text{ msec} = 1 \text{ sec}$  yields  $\sim 1\%$  accuracy, but requires a very high input impedance.

$$\tau = R_i C_g \quad \text{and}$$

$$R_i = \frac{1 \text{ sec}}{35 \text{ pf}} = \underline{2.8 \times 10^{10} \Omega}$$

The current flowing at time  $t_0$  with the voltage  $V$  is:

$$i_0 = \frac{V}{R_i} = \frac{37 \times 10^{-6}}{2.8 \times 10^{10}} = \underline{1.3 \times 10^{-15} \text{ A}}$$

Good electrometer tubes<sup>\*)</sup> of to-day have a grid leakage current in the order of  $3 \times 10^{-15}$  A. Depending on the voltage noise of the tubes, we can adjust the capacity  $C_g$  to minimize the voltage noise and leakage current. Since the noise level is usually in the order of several  $\mu\text{V}$ , we cannot sufficiently increase the  $i_0$  to be much higher than the grid leakage.

Here again we just about reach the limit of to-day's development. New low leakage electrometer tubes or field-effect transistors can help to make this project feasible.

We have so far excluded all the external noise sources which seriously increase the difficulties.

### III. Sources of noise

In general, the same sources of noise are present as discussed for the electromagnetic beam monitor. Here, the magnetic disturbances are less severe, but the electrostatic noise increases. Due to the very high impedance input, we easily can pick up electromagnetic waves. The present design, however, has the tube say near the electrode and thus limits these effects. Shielding may nevertheless be necessary. In the following we shall briefly discuss other important additional noise sources not considered in section A.

#### Ionization of residual gas

R. Kaiser and P. Gottfeld<sup>15/</sup> observed considerable ionization of the residual gas, even at a vacuum of  $10^{-6}$  mmHg. Deposits of these charged particles on the electrodes cause undesirable currents. A negatively biased grid could be inserted inside the electrode to remove the ions and stray-protons.

---

\*) Victoreen 5800/V x 41 A Tetrode

Philips 4068 Pentode

IV. Discussion

Neglecting external noise sources, it seems possible to develop with some research the necessary electronics for the electrostatic beam monitor. The order of magnitude of the external disturbances is not known and only a **step-by-step** increase of sensitivity with the necessary shielding etc. enables us to eliminate all the noise sources. People working on linear accelerators are very pessimistic about the electrostatic pick-up monitor because of charge deposit on the electrodes. Before we complexely reject this possibility I suggest to investigate the possibilities of a grid inside the electrode.

PART C

Comparison of electrostatic and electromagnetic beam monitors

Holcomb et al <sup>13/</sup> made an intensive study of electrostatic and electromagnetic monitors. They investigated in particular position sensitive monitors for proton beams between 0.18 ma - 15 ma which corresponds to  $6 \times 10^8$  p/p. Their analysis shows the superiority of electromagnetic beam monitors because of a better signal to noise ratio.

1. The advantages of the electromagnetic monitors

- a) The output signal is proportional to the beam peak current, thus it discriminates against slowly moving charges.
- b) The stray currents enter the electromagnetic system less because of the short integrating time constant.
- c) Secondary electron emission is a function of the surface area of the pick-up, thus much smaller for the coils.
- d) An electrostatic shield collects free charges moving in direction of the winding.  
(A similar protection could be installed for the static pick-up).
- e) Comparable electrostatic electrodes are much larger than the toroids.

2. The disadvantages of electromagnetic monitors

- a) The construction of a toroid is more complicated than an electrode.
- b) The toroid yields a lower signal.
- c) Shielding of a toroid is much more difficult.

3. Conclusion

From the point of view of signal amplification excluding the external noise, the electrostatic method is closer to realization. However, the difference is minute. Any change of geometry (note the 100 cm long pick-up electrode) may well reverse this statement.



Holcomb et al. did not have the strongly pulsed magnets we are bound to have for the slow ejection, thus its biggest noise sources were ions, stray currents and electronclouds. It is obvious that the electrostatic pick-up is more sensitive to these disturbances.

In our case we lack exact quantitative data, both from magnetic fields induced in the toroid and the intensity of undesired charge deposited on the electrodes. We can at present only predict that for either the case of the electrostatic or the electromagnetic monitors, there will be a high level of noise. We finally conclude that both methods require a considerable amount of research and only a parallel, step-by-step development will enable us to decide the definite superiority of one of the systems.

#### 4. Acknowledgements

I would like to express my thanks to Dr. K.H.Reich who suggested this this work and contributed many valuable thoughts. I am also indebted to K.Unser and Ch.Fabjan for their constructive discussions.

REFERENCES

- 1/ Jack B.Sharp, MPS/Int.CO 62-15. 6.12.1962.
- 2/ Standard Handbook for Electrical Engineers, Sec. 2-71, p.50, formula 2-76.
- 3/ Philbrick Amplifier, data sheet.
- 4/ CPS User's Handbook, Bl p.4.
- 5/ M.Georgijevic MPS. Private communication.
- 6/ PS/Int. MM 59-5, Fig.61. 11th. June 1959.
- 7/ Vacuumschmelze Hanau Deutschland. Firmenschrift.
- 8/ J.Bovet, MPS. Private communication.
- 9/ MPS/Int. CO 63-7 "The Effect of Radiation on some transistors and transistor circuit inside the PS tunnel".
- 10/ V.Radeka, BNL 6953, Field Effect Transistors in charge sensitive Amplifiers.
- 11/ H.Unser, CERN. Private communication.
- 12/ V.Radeka, BNL. Private communication.
- 13/ L.Holcomb et al. Nucl. Instr. and Methods 24 p.399, 1963.
- 14/ Standard Handbook for Electrical Engineers.
- 15/ R.Kaiser and P.Gottfeld, Cern. Private communication.
- 16/ MPS/Int. DL 63-13, Fig. V 24.

SUGGESTED CONSTRUCTION OF A MAGNETIC BEAM MONITOR  
FOR THE SLOWLY EJECTED BEAM

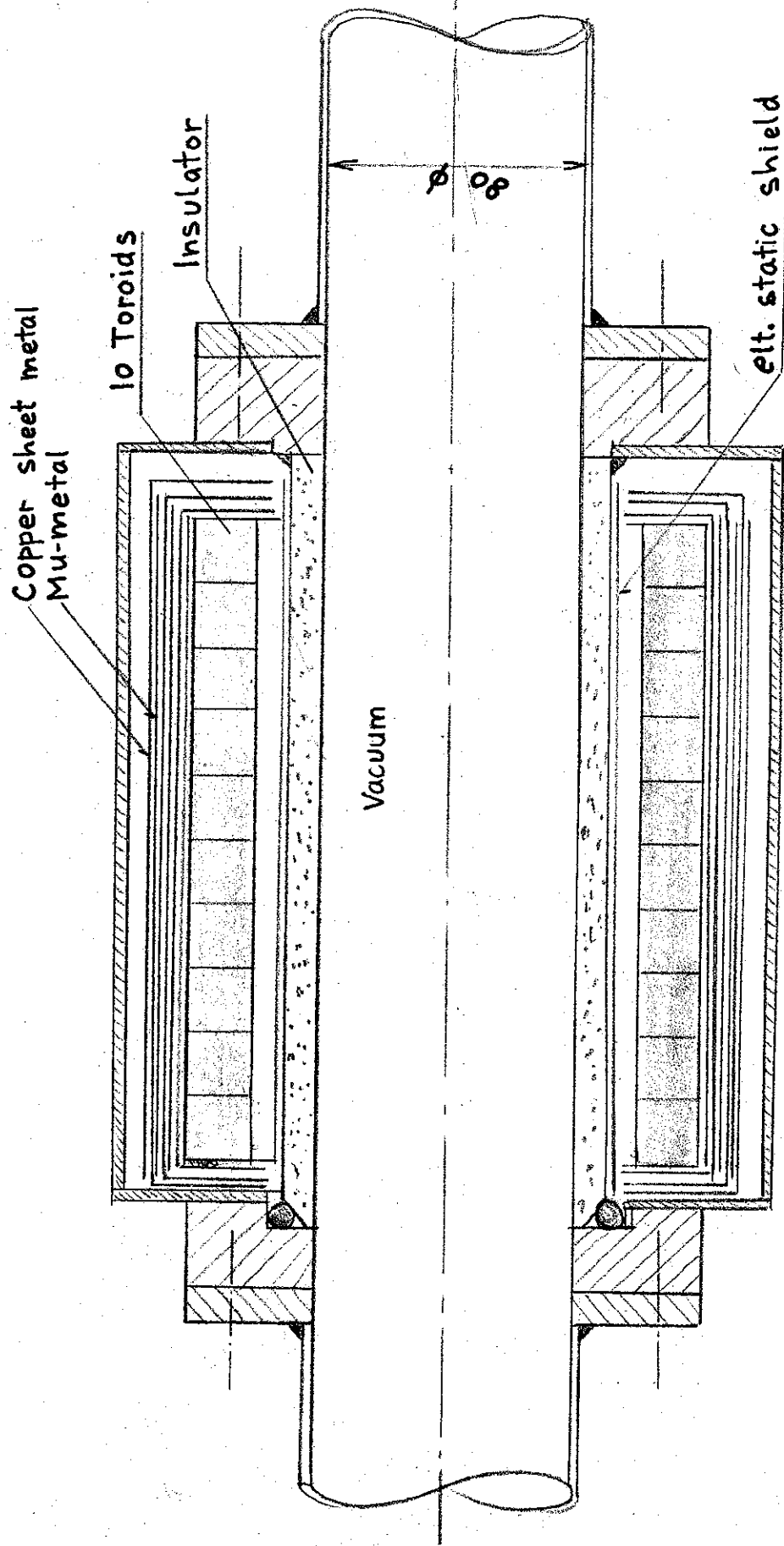

Fig. 2 , Dimensions are for Section between B3 and Q3  
of. ETA

M = 1:2



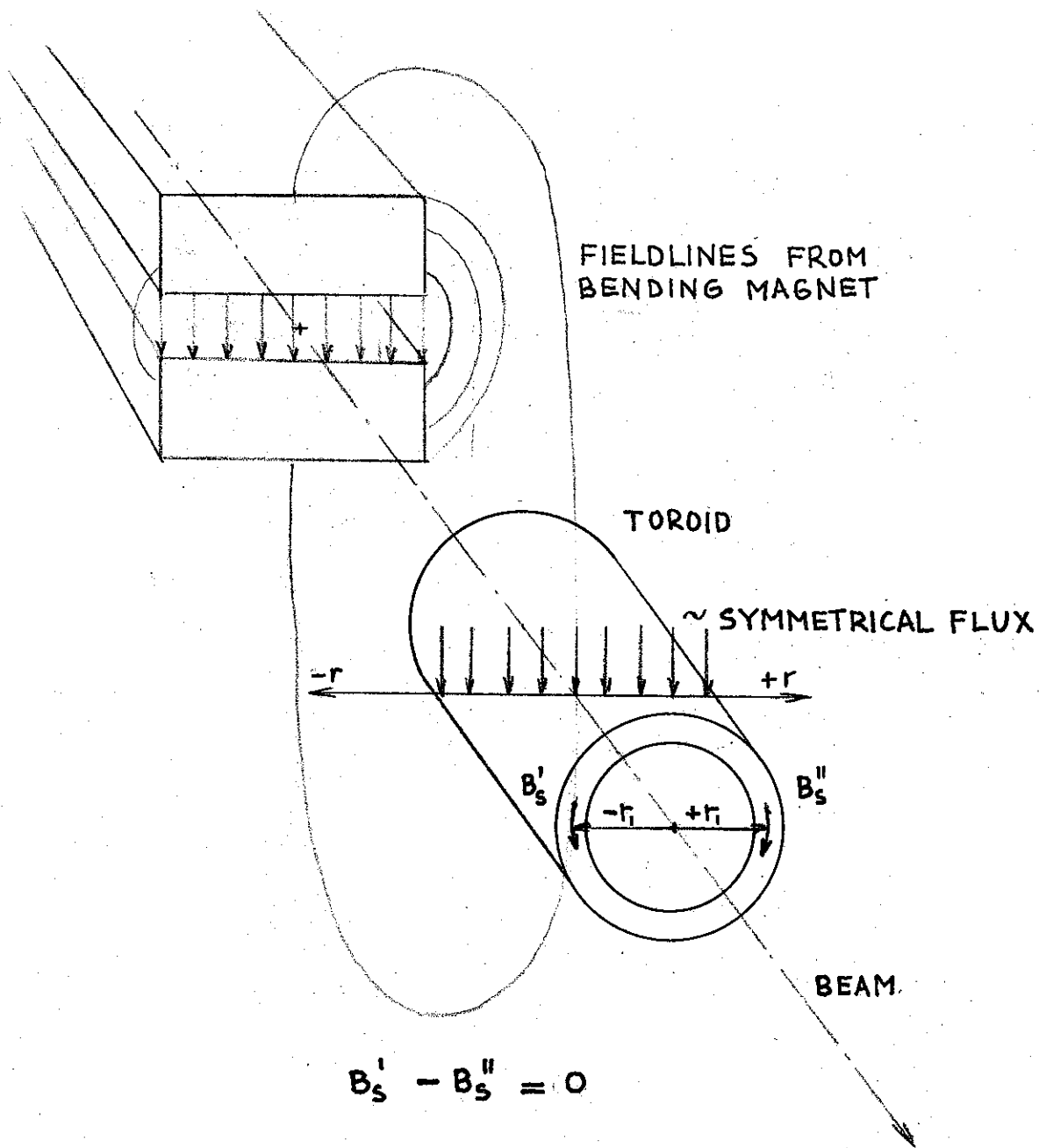

FIG. 3., THE FIELD OF THE BENDING MAGNET IS QUITE HOMOGENIOUS OVER  $-r_1$  to  $+r_1$ , AND INDUCES A SYMETRICAL FLUX IN THE TOROID WHICH RESULTANT IS ZERO.



THE FIELD OF THE BINDING SHEET IS  
QUITE HOMOGENEOUS OVER  $\pi \times \pi$  AND  
INVOLVES A SYMMETRICAL FLUX IN THE TOROID  
WHICH RESULTS IN ZERO

Fig. 3

POSITION OF TOROID IN SLOWLY EJECTED BEAM: (STRAIGHT. S. 60)

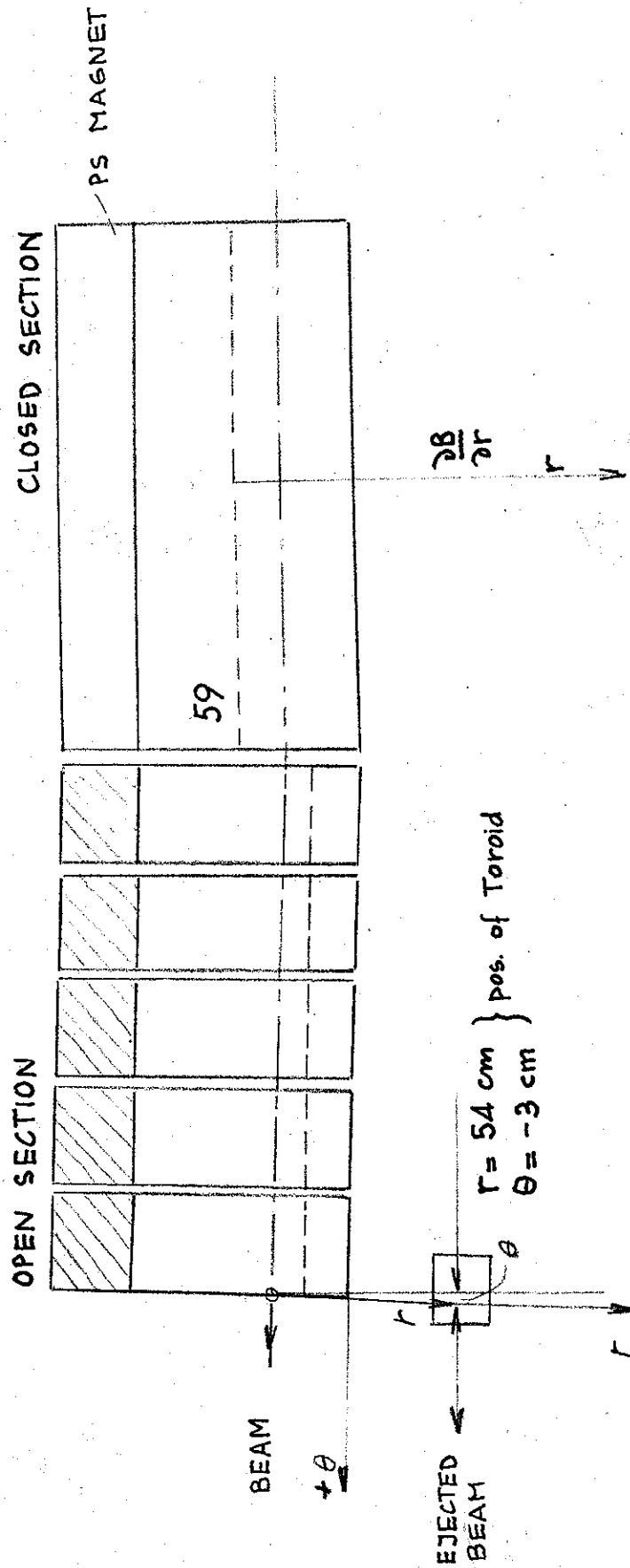

$$B(r, \theta) = B(54, -3) \approx 0.01 \text{ Wb/m}^2$$

$$\left(\frac{\partial B}{\partial r}\right)_{r, \theta} \approx 0.1 \frac{\text{Wb}}{\text{m}^3}$$

Fig 4., Reference: PS/Int MM 59-5 Fig. 61 extrapolated r to 54 cm  
11th June 1959

References: The same as in the previous report.

$$\left(\frac{1}{2}\right)^{10} = \frac{1}{1024}$$

Probability of error = 1/1024

RESULTS

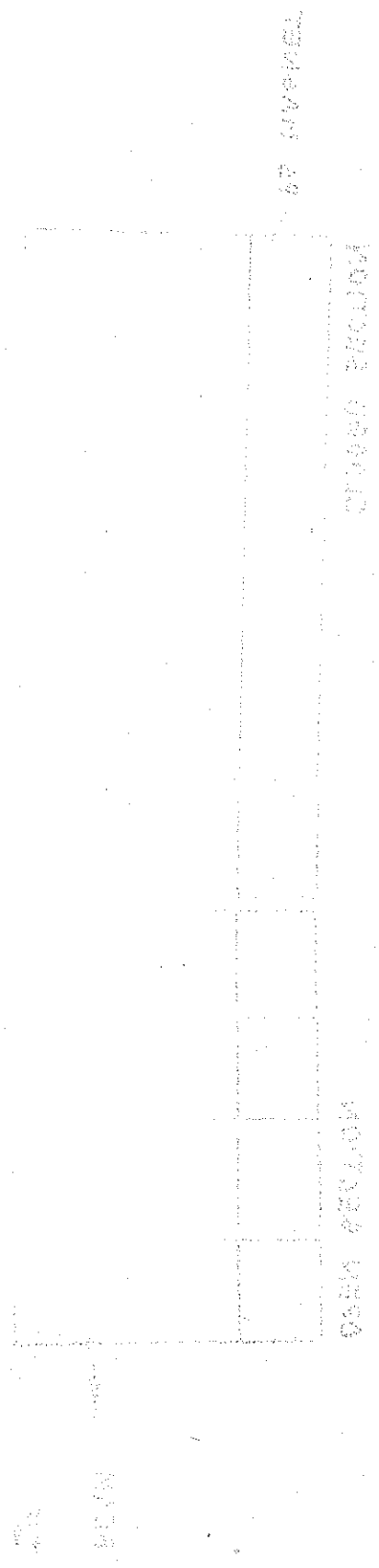

Probability of error in 10 trials = 1/1024



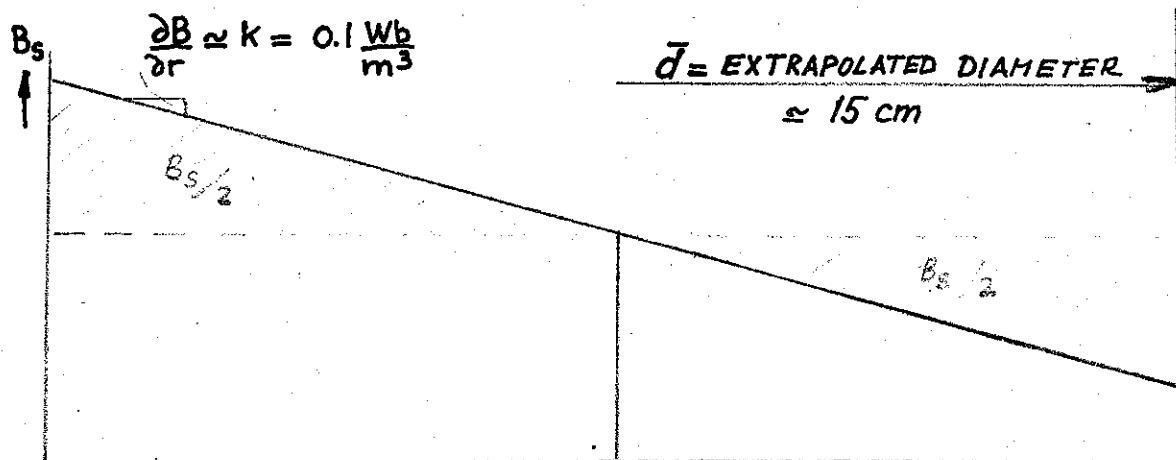
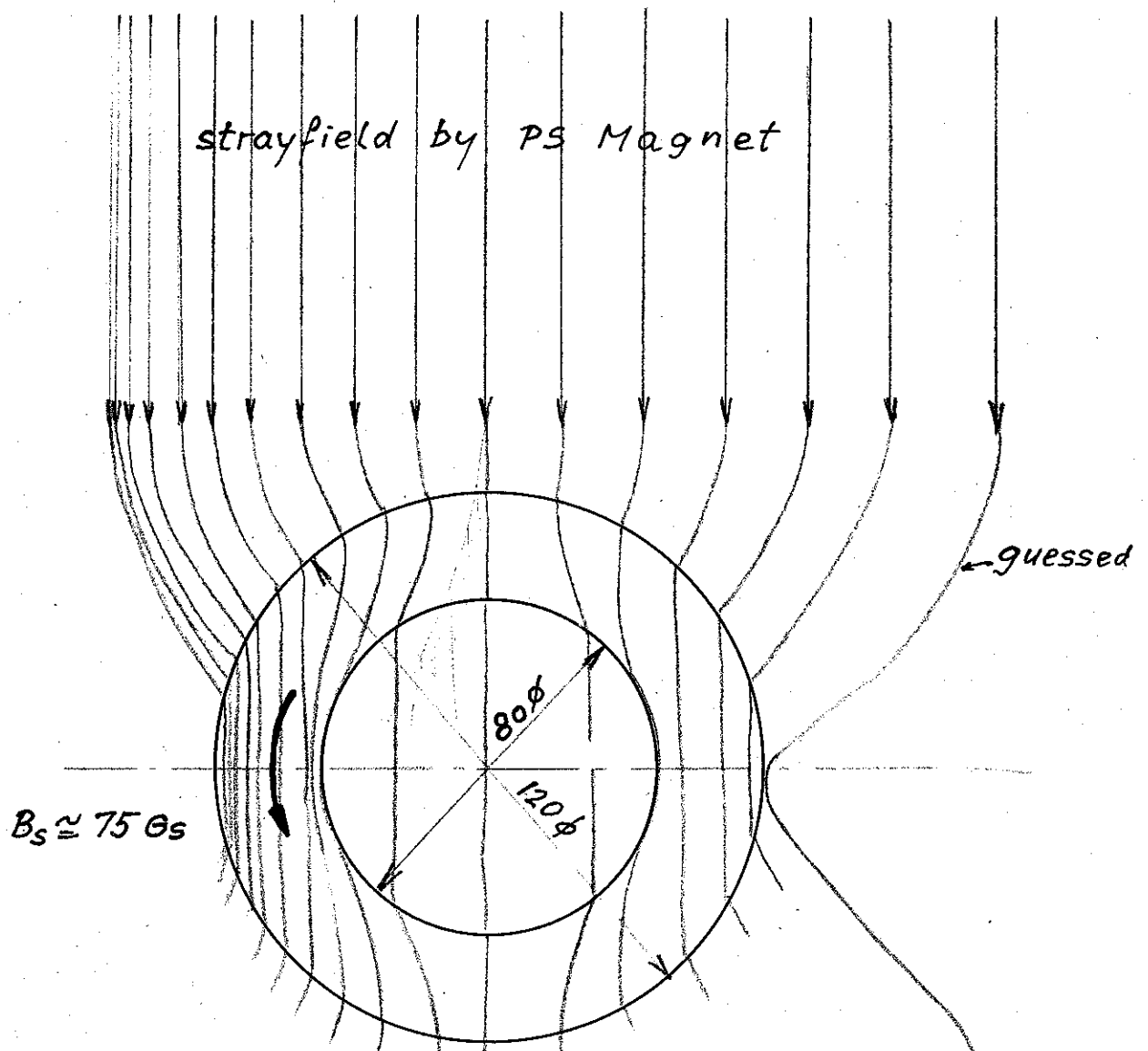

$$B_s \approx \frac{\partial B}{\partial r} \frac{\bar{d}}{2} = \frac{0.1 \text{ Wb}}{2 \text{ m}^3} 0.15 \text{ m} = \underline{\underline{75 \text{ Gs}}}$$

FIG. 6, APPROXIMATE FIELD IN TOROID INDUCED BY P.S. MAGNET.

Approximate field in Northwood by 25th April

1 2 3 4 5 6 7 8 9 10 11 12 13 14 15 16 17 18 19 20 21 22 23 24 25 26 27 28 29 30 31 32 33 34 35 36 37 38 39 40 41 42 43 44 45 46 47 48 49 50 51 52 53 54 55 56 57 58 59 60 61 62 63 64 65 66 67 68 69 70 71 72 73 74 75 76 77 78 79 80 81 82 83 84 85 86 87 88 89 90 91 92 93 94 95 96 97 98 99 100

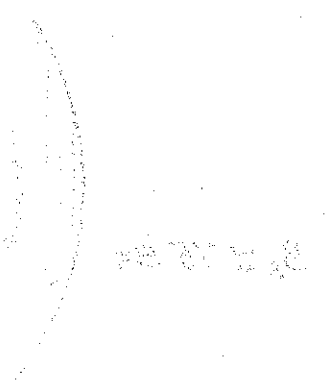

Approximate field in Northwood by 25th April

Approximate field in Northwood by 25th April

Approximate field in Northwood by 25th April