

Figure S1 AGCSE-Net model structure.

Table S1 Detection and segmentation performance of AGCSE-Net model in our cohort

	Detection				Segmentation
	Accuracy (%)	Precision (%)	Sensitivity (%)	Specificity (%)	DSC
AGCSE-Net	91.0	70.6	94.8	90.0	0.75

DSC, Dice score coefficient.

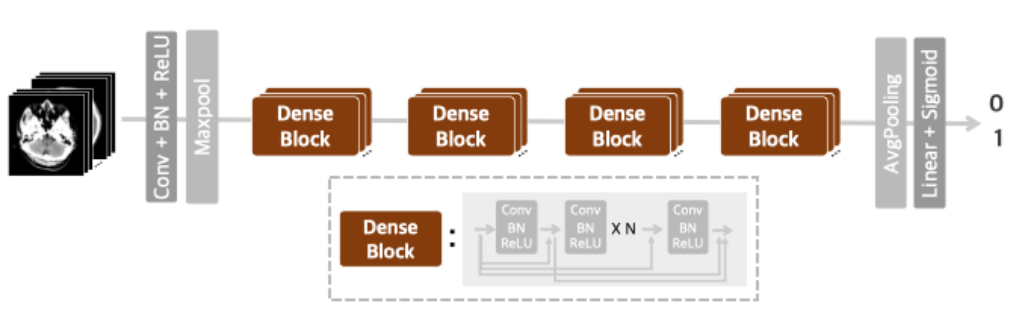

Figure S2 Structure of DenseNet.

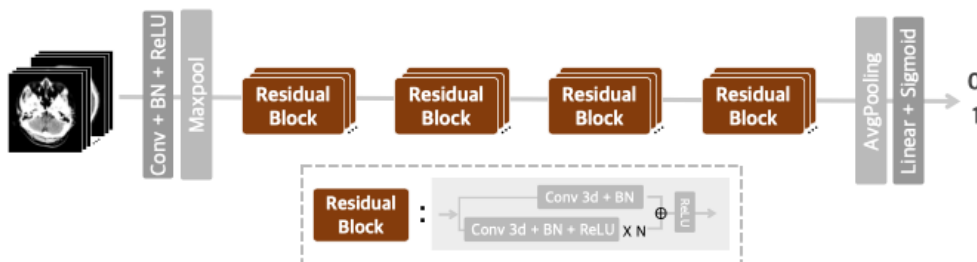

Figure S3 Structure of ResNet.