

OPERATIONAL EXPERIENCE AND TECHNIQUES FOR CONTROLLED LONGITUDINAL PHASE SPACE DILUTION IN THE AGS USING A HIGH HARMONIC CAVITY*

R.K. Reece, L. Ahrens, A. Abola, J.M. Brennan, P. Cameron, D. Ciardullo, A. Dunbar, W. Frey, M.A. Goldman, D. Kasha, J. Kats, A. McNerney, A. Otis, E. Raka, R. Sanders, P. Stein, W. van Asselt, A. Zaltsman
AGS Department, Brookhaven National Laboratory
Associated Universities, Inc., Upton, NY 11973 USA

Summary

A fixed frequency 93 MHz harmonic cavity has been installed in the AGS ring. The primary purpose of this harmonic cavity is to increase (dilute) the longitudinal phase space area occupied by the beam by as much as a factor of four (to 4.0 eV-s) in a controlled, rapid manner while maintaining a smooth local density. This then will permit essentially lossless passage through transition energy (8.0 GeV) at intensities higher than previously achieved. Although the system controls permit as many as five dilutions per AGS cycle, only one is used at present. Effects of the various phase modulation programs, excitation period, and rf voltage programs on the dilution rate have been modeled.¹ The parameters predicted to yield the best dilution have been implemented with satisfactory results. Further, a beginning has been made to explore the parameter space experimentally in order to determine the programs leading to the desired degree of dilution without loss of beam in the minimum time.

Objectives

A Very High Frequency (VHF) rf system can be used to minimize beam loss during the acceleration cycle by reducing the particle density within the bunches. At present, the efficiency of passage through transition at high intensity in the AGS (1.5×10^{13}) is less than 95%. With the completion of the AGS Booster synchrotron in 1991,² injecting into the AGS at 1.5 GeV, the intensity limit due to space charge tune shifts will be increased by approximately a factor of four. At this projected intensity, a 5% transition loss could not be tolerated because of the resulting machine activation.

The VHF cavity is tuned to a frequency of 93.152 MHz which is an integer multiple of the beam revolution frequency. During the brief dilution periods (200 ms), the AGS guide field is held fixed and the rf drive to the cavity is activated, phase modulated relative to the revolution frequency reference. The phase modulation frequency itself is set near three times the synchrotron frequency but is also varied slightly. Experiments at the PS at CERN³ originally suggested this general approach to optimal dilution. The net effect on the beam of the phase modulated VHF cavity together with the normal acceleration cavity system (operating with stationary buckets and at a reduced voltage) is to produce bunch filamentation on a very fine scale and a controlled uniform dilution in longitudinal phase space. The effective bunch area will be increased by approximately a factor of two during each dilution period, the limit defined by the phase space area available.

Physical Considerations

The VHF dilution cavity in use at the AGS is a shorted quarter-wave coaxial TEM structure.⁴ There *Work performed under the auspices of the U.S. Department of Energy.

is no ferrite used in the cavity and so no fast tuning of the system is possible. Thus, the operating frequency is defined by the mechanical design. For a given set of active dilutions per AGS cycle, the frequency of the cavity is fixed. This frequency may be changed over a small region by a mechanical tuning system that moves a sleeve attached to the inner conductor through a range of 0.2" corresponding to approximately 600 MHz, but the change is a global one for all the dilutions throughout the entire cycle. While the frequency may not be changed dynamically, this method permits precision setting of the cavity frequency. The cavity is approximately one meter in length (Figure 1) and has been installed in a ten-foot straight section in the AGS. Rf power for the cavity system is provided via a coaxial transmission line from a commercial FM transmitter located in a power supply house 350 feet from the cavity.

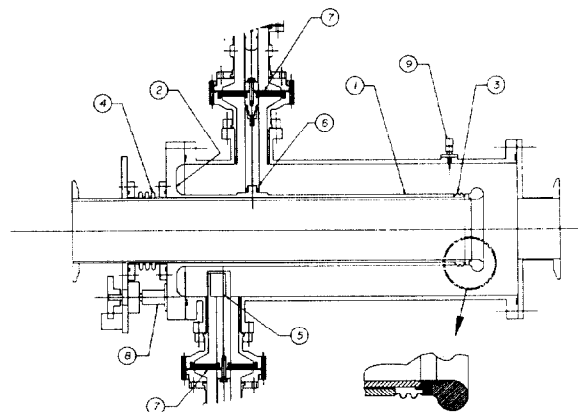

Figure 1. The 93 MHz Cavity; (1) inner conductor, (2) shorting plate, (3) rf bellows, (4) vacuum bellows, (5) power feed loop, (6) connection to PIN diode switch, (7) ceramic window, (8) tuner power screw, (9) monitor probe.

A "de-Qing" switch physically attached to the cavity is used to shunt the cavity to a low impedance state during non-dilution times in the acceleration cycle. When the cavity is not powered, the de-Qing switch is just a terminated (into 50 Ω) transmission line. However, when power is to be applied to the system, a PIN diode array causes a point in that transmission line, 3/4 wavelength from the cavity, to be shorted. A voltage node at this physical short places the cavity in a high Q state.

Operational Procedures

To minimize voltage induced in the VHF cavity by the circulating beam, one should avoid certain harmonics present in the beam. Multiples of the rf accelerating frequency are always present, even with equal bunches, so these frequencies should be avoided. The AGS Booster synchrotron will inject synchronously into the AGS (bunch to bucket) four

batches of three bunches each. The harmonics contained in three adjacent bunches (the result of one Booster transfer or unequal transfers) include all multiples of the revolution frequency except $(n + 1/3)f_{rf}$ and $(n + 2/3)f_{rf}$. These then are the best frequencies to select to minimize beam loading.

In the present operation of the VHF cavity, only one dilution period is used. Further, because the ring is fully populated, any harmonic of the rotation frequency, except the ring rf harmonics is acceptable. Since the Booster synchrotron will inject into the AGS at an energy of 1.5 GeV, this is the present energy selected for beam dilution in the AGS. The fine adjustment of the cavity resonant frequency is carried out by positioning the mechanical tuner to maximize the cavity voltage and minimize the reflected power. Closed loop operation to keep the cavity at resonance is done by a comparison of the VHF cavity phase relative to the output of the power amplifier. The cavity tuner then makes corrections if the phase detector output exceeds a user-defined limit. The low level rf drive to the VHF cavity power amplifier is derived from a beam pickup signal. The revolution frequency is multiplied up to the VHF cavity frequency using a phase lock loop. In this way, a reference phase is provided for the cavity which remains synchronized with the particles in the machine. In order for this rf output to excite the cavity, the frequency must fall within the cavity bandwidth (60 kHz). This puts tight constraints on the revolution frequency on the dilution porch or equivalently on the reproducibility of that porch. To somewhat relax this tolerance, an additional phase lock circuit was built which holds the revolution frequency at the desired frequency (provided by an independent synthesizer) once lock has occurred, at the expense of the beam radial position.

In the AGS, the main guide field power is provided by the Siemens motor-generator set. Full computer control is not yet implemented in this system; however, one main magnet flattop is available in addition to the standard slow resonant extraction flattop (Figure 2).

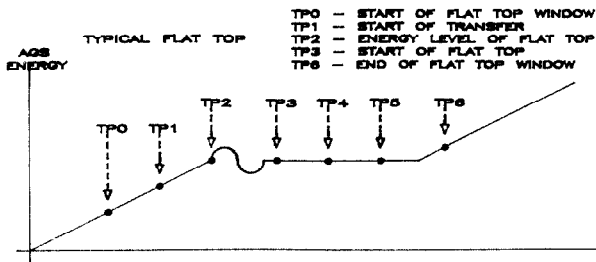

Figure 2.

Stability of this early flattop had been unacceptable in the first tests of the VHF cavity. Significant improvements have since been made to the system and the reproducibility of the main guide field is now ± 0.14 Gauss or, expressed in terms of the accelerating rf frequency on the 1.5 GeV flattop, ± 100 Hz (Figure 3). This stability is such

that there is no need to activate the circuit mentioned above which locks the AGS to an external oscillator.

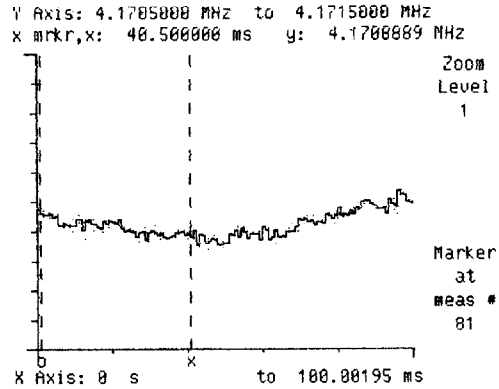

Figure 3. Ring rf frequency vs. time on the dilution porch.

The control of the VHF cavity system is accomplished through the new AGS Distributed Control System (AGSDCS).⁵ Some of the older variables such as timing and functional control of associated devices, etc., still reside on the previous main frame computer; so, presently the operation of the VHF cavity requires using both control systems.

Initial Results

Bunch measurements in the AGS were done using a wide band wall monitor. In order to assess the efficiency of the dilution process, it is essential to note that the bunch image (azimuthal projection) increases in length and decreases in peak amplitude while the circulating beam intensity remains constant (Figure 4).

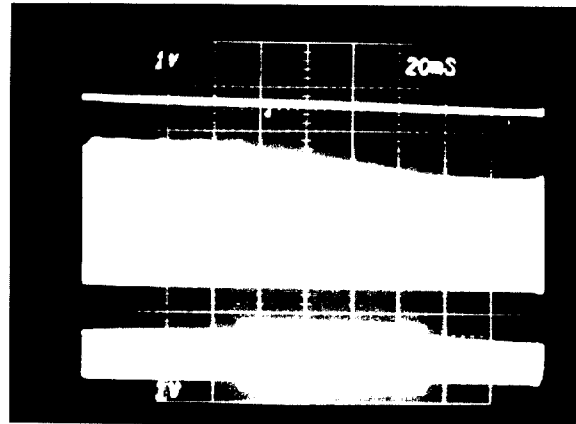

Figure 4. Top: circulating beam current; Center: wall monitor; Lower: VHF cavity drive.

Listed in Table I are operating parameters for the VHF cavity and are very close to those suggested from the model.

Table I
Operating Parameters

$f_{\text{vhf}}/f_{\text{rf}}$	22-2/3
Cavity Frequency	93.152 MHz
Cavity Voltage	25 kV
Main RF Accelerating Voltage	140 kV
Main RF Frequency	4.11 MHz
Dilution Period	50 ms
Frequency of Phase Modulation	6.1-6.7 kHz
Phase Modulation Sweep Period	4 ms
Phase Deviation	$\pm 65^\circ$

An average over several pulses of bunch measurements was taken on the dilution porch at times immediately before (TP3) and after (TP5) the cavity was powered. The result was slightly more than a factor of two increase in bunch width and a 40% reduction in the peak bunch amplitude (Figure 5).

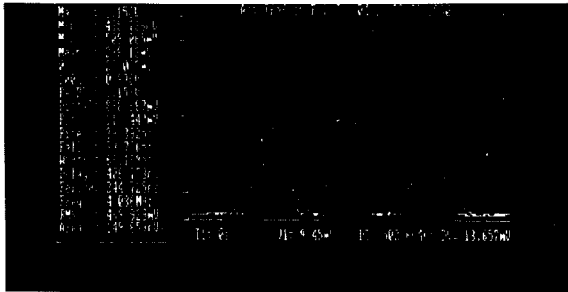

Figure 5. Bunch distribution before and after dilution.

Under these operating conditions, the bunch area was increased by more than a factor of two from 0.76 eV-s to 1.68 eV-s (Table II). To verify that there was no other unforeseen mechanism involved with the dilution process, another set of bunch measurements were taken at the end of the dilution period (TP5) without having powered the VHF cavity on the flat-top. This result was nearly identical with the measurement before (at TP3) indicating that the dilution noted was due entirely to the action of the VHF cavity operation.

Table II
Beam Measurements

Main RF Bucket Area	3.29 eV-s
Bunch Length at Time TP3	86.7 ± 2 ns
Bunch Length at Time TP5 (VHF On)	124.9 ± 2 ns
Bunch Length at Time TP5 (VHF Off)	86.8 ± 2 ns
Bunch Area at Time TP3	0.76 eV-s
Bunch Area at Time TP5 (VHF On)	1.68 eV-s
AGS Beam Intensity	5×10^{10} protons/pulse

Recent Progress and Future Commissioning

The effect of powering the VHF cavity on a beam of higher intensity (1×10^{13} protons/pulse) was examined recently. The cavity was powered for 80 ms on a main magnet porch again corresponding to a beam energy of 1.5 GeV (Table III).

Table III
Operating Parameters

$f_{\text{vhf}}/f_{\text{rf}}$	22-1/2
Cavity Frequency	93.152 MHz
Cavity Voltage	20 kV
Main RF Accelerating Voltage	165-220 kV
Main RF Accelerating Frequency	4.14 MHz
Dilution Period	80 ms
Frequency of Phase Modulation	6.0-7.0 kHz
Phase Modulation Sweep period	4 ms
Phase Deviation	$\pm \pi$

In general, the dilution results at high intensity reproduced those acquired in earlier work at an intensity lower by more than two orders of magnitude with similar operating parameters for the VHF cavity (Table IV).

Table IV
Beam Measurements

AGS Beam Intensity	1×10^{13} protons/pulse
Main RF Accelerating Voltage	220 kV
main RF Bucket Area	4.11 eV-s
Bunch Length at Time TP3	80 ± 5 ns
Bunch Length at Time TP5	110 ± 5 ns
Bunch Area at Time TP3	0.82 eV-s
Bunch Area at Time TP5	1.47 eV-s
Main RF Accelerating Voltage	165 kV
Main RF Bucket Area	3.57 eV-s
Bunch Length at Time TP3	80 ± 5 ns
Bunch Length at Time TP5	135 ± 5 ns
Bunch Area at Time TP3	0.71 eV-s
Bunch Area at Time TP5	1.81 eV-s

In the study at high intensity, the dependence of the dilution rate as a function of $V_{\text{vhf}}:V_{\text{rf}}$ was investigated. As predicted by the model, reducing the voltage of the main rf accelerating system increased the dilution rate. Another measurement showed that if the VHF cavity was powered but with no phase modulation, there was no bunch dilution. In addition, a beginning was made with respect to the form that the phase modulation program should taken to yield the most efficient dilution.

Acknowledgments

The design and implementation of essential modifications to the controls of the main magnet power supply were carried out by A. Feltman, J. Gabusi, J.W. Glenn, and S. Naase. Without the improved stability of the magnet porch, the operation of the VHF cavity would not have been possible.

References

1. J.M. Kats, IEEE Particle Accelerator Conf., 1281, 1987.
2. AGS Booster Design Manual, October, 1988.
3. D. Boussard, The PS 200 MHz RF System Present Situation and Future Prospects, CERN-SPS/ARF/78-6.
4. J.M. Brennan, et al., A High Harmonic Cavity for Controlled Longitudinal Phase Space Dilution in the AGS, EPAC, Rome, 1988.
5. A. Abola, et al., IEEE Particle Accelerator Conf., 594, 1987.