

FULL CHARACTERIZATION OF THE PIEZO BLADE TUNER FOR SUPERCONDUCTING RF CAVITIES

Angelo Bosotti, Carlo Pagani, Nicola Panzeri, Rocco Paparella, INFN/LASA, Segrate (MI)
 Jens Knobloch, Oliver Kugeler, Axel Neumann (BESSY GmbH, Berlin)
 Clemens Albrecht, Kay Jensch, Rolf Lange, Lutz Lilje (DESY, Hamburg)

Abstract

Cavity tuners are mechanical devices designed to precisely match the resonant frequency of a superconducting (SC) cavity to the RF frequency synchronous with the beam. The blade tuner is mounted coaxially to the cavity and changes the resonator frequency by varying its length. A high tuning range is desired together with small mechanical hysteresis, to allow for easy and reproducible resonator setup operations. A high stiffness of the tuner system is also necessary both to ensure mechanical stability and to mitigate the frequency instabilities induced by perturbations. In high gradient SC resonators, the main sources of resonant frequency instability are the Lorentz Force Detuning (LFD) under pulsed mode operation, and the microphonic noise, in continuous wave (CW) with high loaded quality factors. Piezoelectric ceramic (piezo) elements add a dynamic tuning capability to the system, allowing fast compensation of these instabilities with the help of feedforward and feedback loops. The piezo blade tuner has been extensively tested assembled on a TESLA type cavity in its final configuration. Tests were done both at room temperature and under cryogenic conditions. This paper presents the summary of the complete characterization tests.

INTRODUCTION

The blade tuner working principle is to transfer azimuthal rotation, provided by a stepper motor into longitudinal motion by means of bending blades [1, 2]. The device that has been tested inside CHECHIA and HoBiCaT is an enhancement of the TTF superstructures tuner, where the design has been simplified in view of the ILC requests, and completed with the insertion of the piezos for dynamic tuning operations.

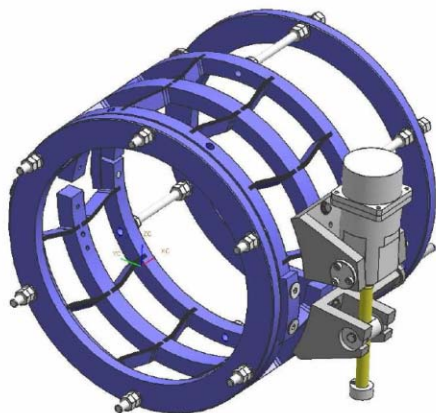

Figure 1: The Blade Tuner with its driving system

The coaxial blade tuner is presented in Fig. 1. The driving system is also visible, mainly composed of the motor with its gears and a CuBe screw. The axial movement of the nut is directly transferred into the rotational one by the central rings. Two prototypes of this device have been realized, one made from Titanium and the other from Stainless Steel (SS) with Inconel blades. The two new tuners were first tested at LASA at room temperature to check mechanical properties: after these tests we decided to use the SS – Inconel tuner for cold tests [3].

COLD TESTS

The first cold test inside horizontal cryostats has been performed, inside CHECHIA, at DESY, in pulsed RF regime [3]. Then two other test sessions with CW RF have been done inside HoBiCaT, at BESSY. The tuner has been installed at DESY on the Zanon n°86 cavity (Z86), using a modified He tank, with the insertion of a central bellow, to allow for coaxial tuning operation. For the CHECHIA test, a stepper motor from Sanyo inc. has been installed, equipped with a harmonic drive gear. Two low-voltage, multilayer piezos from Noliac, 40 mm long and with 10x10 mm² cross section, have been installed as active elements. In Fig. 2 the tuner installed on the helium tank at DESY HALLE III machine shop, together with one of the piezos, can be seen.

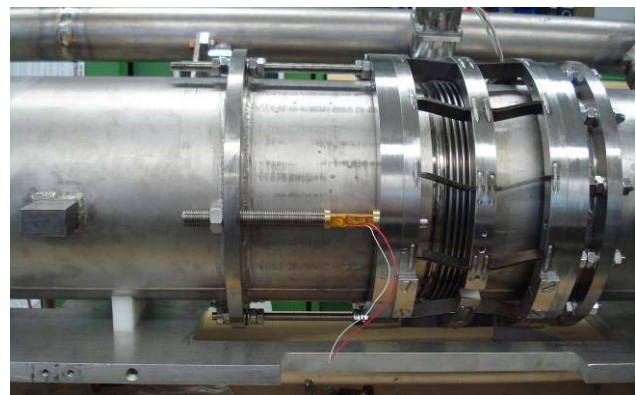

Figure 2: The blade tuner completely installed; piezo actuators are in place and preloaded. The central bellow is also visible.

The correct preload [1] to the piezos is given using the screws connected to the piezo supports. The goal pre-load value, about 1.5 kN on each piezo, is reached when the cavity is cooled at 2 K, taking into account all the cavity length changes, due to thermal contractions and pressure gradient sustained during the cooldown operation. The

piezo load value is determined through the read-out of the resonant frequency difference between room temperature and 2 K cold conditions, assuming 3 kN/mm cavity elastic constant.

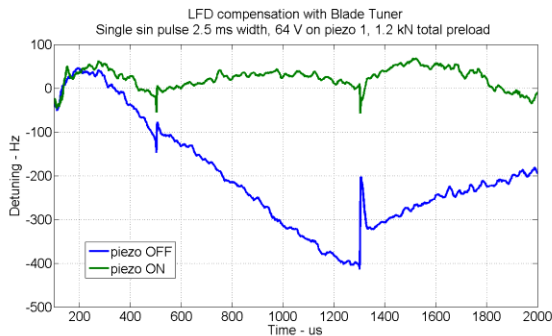

Figure 3: Z86 cavity detuning with and without piezo active compensation

During CHECHIA tests (September 2007), the entire Lorentz force detuning shown by Z86 cavity at full gradient, in different load conditions, has been successfully compensated. The plots in Fig. 3 correspond to the best results obtained in the higher piezo pre-load configuration considered (1.2 kN total force). Looking to the picture one can see that a detuning of about 300 Hz during the pulse flat top is compensated. This was achieved using just one piezo, fed with one third of the nominal piezo maximum driving voltage.

The static tuning range was also measured using a vector Network Analyzer to read the cavity resonant frequency while moving the tuner stepper motor. The results are shown as function of screw turns, in Fig. 4, red trace.

We stopped at 13 complete spindle turns, getting a tuning range of 520 kHz, (the former requested tuning range was 500 kHz), with peak sensitivity value of 50 kHz per screw turn as expected from the tuner design specifications. A visible hysteresis is anyway present in the red trace of Fig. 4, where a frequency difference of 16 kHz remains after a complete load cycle. The hysteresis can be explained by the need of a “load conditioning” of the tuner itself, since the installed setup reached these high load values for the first time during this test. As will be shown in the following tests at BESSY, the hysteresis is effectively greatly reduced by further load cycles.

After the test in pulsed regime at DESY, the tuner was transferred to BESSY, to be tested on February 2008, inside the CW facility HoBiCaT, that allows better investigations on tuning range and transfer functions. A Phytion stepper motor, provided with a planetary gear box, has been used in place of the former Sanyo stepper motor with harmonic drive gear. It must be remarked that this configuration was used for the first time for this application, and that the new gear box has a speed reduction ratio of 1:100, while the harmonic drive one was 1:88.

The full Blade Tuner frequency range has been measured using the cavity closed in a Phase Locked Loop

(PLL) to track the cavity frequency displacement. It took 205000 motor steps, corresponding to 10 complete turns of the CuBe screw, to cover the desired tuning range of about 520 kHz, for a direct comparison with the former test inside CHECHIA. The measure has been repeated three more times, although the last time we have stopped at one half of the trip backward (100000 steps) to perform a short range measurement. All tuning range measurements are summarized in Fig. 4, compared with the one measured in CHECHIA. An additional slow tuning range test has been performed on April 2008, with the aim of pushing the tuner to its limits, achieving the results of 720 kHz tuning range (green trace). The initial piezo preloads were different for the three tests.

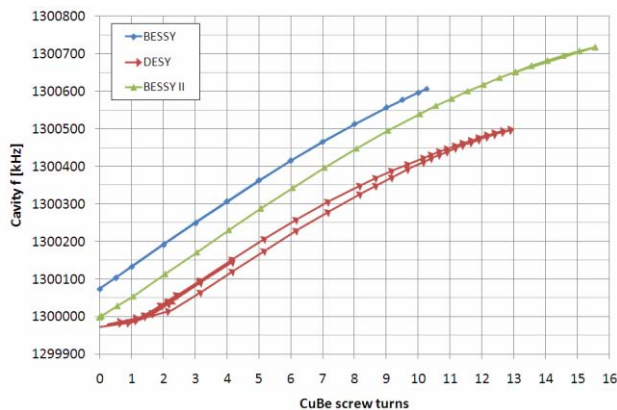

Figure 4: Tuning range test results, inside CHECHIA and HoBiCaT. The reduction of the hysteresis is evident.

The full tuning range meets expectations and the large hysteresis measured at DESY has been significantly lowered to 380 Hz, after the 2nd cycle and lowered even further after the 3rd one. The 4th cycle was almost identical to the former one, meaning that all mechanical settling was reached.

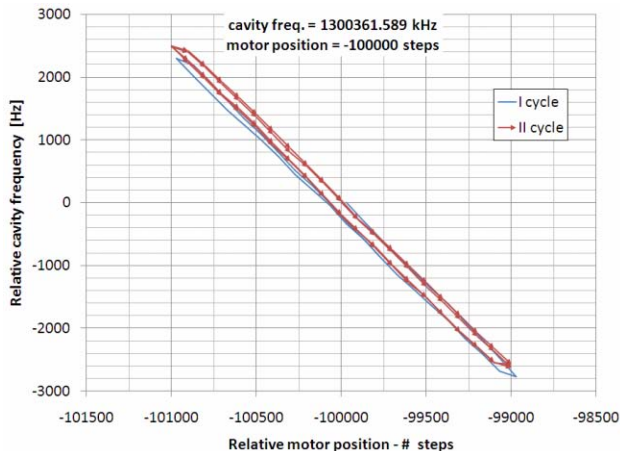

Figure 5: Short range tuning test

Figure 5 shows the results of the “short range” test, sweeping the motor by +/- 1000 steps (100 step sensitivity) around the -100000 steps position, chosen because it revealed to be the working point with the highest hysteresis width. Several complete cycles have

been performed and the last measurement (made up by two complete cycles) is highlighted in the plot.

The assembly behaved as expected for what concerns the ± 1000 steps curves. A backlash like effect is visible at both edges of the curve in Fig. 5, and the overall frequency offset Δf of about 200 Hz (over the selected range of 5 kHz) and less than 100 steps required to cover it, are comparable with the behavior of the TTF I tuner.

During the CW RF tests inside HoBiCaT, a further important step towards the tuner characterization has been obtained measuring the cavity frequency drift induced by the piezos when stimulated by a DC driving voltage. The frequency shift is easily tracked closing the PLL loop. This analysis allows evaluating also the different efficiency of the two piezos in transferring their stroke to the cavity, showing that higher piezo load means higher piezo efficiency.

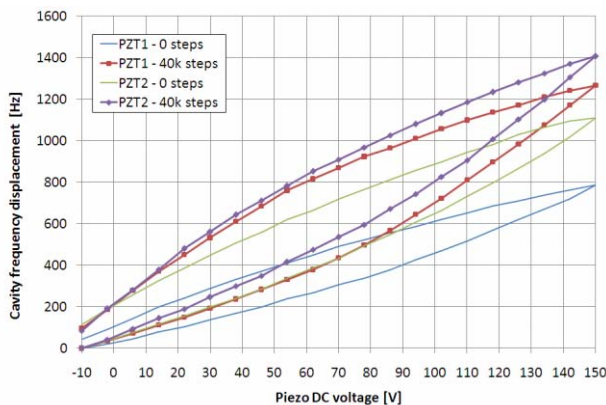

Figure 6: Freq. displacement with one piezo driven

Measurements were done by first driving only Piezo # 1 (installed on motor side of the tuner), then repeating for Piezo # 2 alone, and finally for both piezos in parallel. The piezo driver used was a Physics Instrumente (PI) piezo amplifier, with +150 V maximum output voltage, with the exception of the last test, where a high voltage device from PiezoMechanik (1000 V max voltage) was used to feed both piezos with 200V driving voltage.

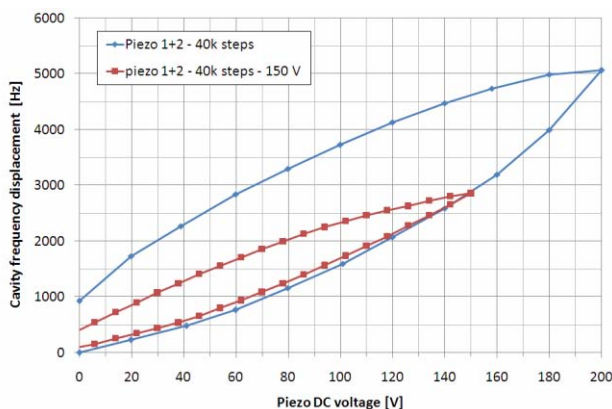

Figure 7: Freq. displacement when both piezos are driven

The typical hysteresis of this kind of PZT ceramic actuator can be also observed as expected, Fig. 6 and Fig. 7. First curves were acquired with the tuner set at the

lower end of the tuning range, corresponding to 0 steps. Then, the stepper motor has been moved to -40000 steps position. This corresponds to an overall compressive load on the tuner of about 2 kN and let us evaluating the difference in piezo stroke and hysteresis as a function of the load, as can be seen in Fig. 6, for single piezo operation, and Fig. 7, with both piezos involved. The graph of Fig. 7 also shows that a frequency shift of 5 kHz is reached when the driving voltage for the paralleled piezos is 200V.

Moreover, very accurate “piezo-to-RF” and “piezo-to-piezo” transfer functions have been acquired during overnight measurements. For the results of further tests please refer to [4], also presented at this conference.

CONCLUSIONS

After the cold tests inside CHECHIA and HoBiCaT facilities, it is possible to say that coaxial Blade Tuner has successfully passed the prototype test. About 720 kHz of tuning range has been achieved, with a total load of about 7 kN, successfully borne by the tuner with no failure. The non negligible hysteresis of the first test inside CHECHIA has been greatly reduced when tests were done inside HoBiCaT, passing from the former frequency error of 16 kHz to the current maximum frequency uncertainty of 380 Hz, over a full frequency span. Pulsed tests inside CHECHIA has shown the tuner high effectiveness in LFD compensation, this latter confirmed in the CW tests driving the piezos with DC voltages up to 200 V, where a static frequency shift superior to 5 kHz has been obtained. This is expected to correspond to more than 3.5 kHz frequency shift in dynamic regime [4] (for 1.3 ms long RF pulses), and so assuring great margin for the compensation of the LFD expected to be 1 kHz for ILC cavities at 35 MV/m accelerating gradient.

ACKNOWLEDGEMENTS

This activity has been partially supported by the EC-Research Infrastructure Activity under the FP6 "Structuring the European Research Area" program (CARE, contract number RII3-CT-2003-506395).

REFERENCES

- [1] A. Bosotti, C. Pagani, N. Panzeri, R. Paparella, “The Coaxial Blade Tuner – Final Report and Evaluation of Operation”, SRF CARE Report, 2008
- [2] D. Barni, A. Bosotti, C. Pagani, R. Lange, H.B. Peters, “A New Tuner For TESLA”, Proceedings of EPAC2002, Paris, France, p. 2205.
- [3] C. Pagani, A. Bosotti, N. Panzeri, R. Paparella, P. Pierini, C. Albrecht, R. Lange, L. Lilje “Piezo-Assisted Blade Tuner: Cold Test Results”, proceedings of SRF 2007, Peking University, Beijing, China.
- [4] R. Paparella, “A control and systems theory approach to the high gradient cavity detuning compensation”, this conference.