

TRANSATLANTIC TRANSPORT OF FERMILAB 3.9 GHZ CRYOMODULE FOR TTF/FLASH TO DESY*

M.W. McGee[#], V. Bocean, C. Grimm and W. Schappert
Fermi National Accelerator Laboratory, Batavia, IL 60510, U.S.A.

Abstract

In an exchange of technology agreement, Fermilab built and will deliver a 3.9 GHz (3rd harmonic) cryomodule to DESY to be installed in the TTF/FLASH beamline. This cryomodule delivery will involve a combination of flatbed air ride truck and commercial aircraft transport to Hamburg Germany. A description of the isolation and damping systems that maintain alignment during transport and protect fragile components is provided. Initially, transport and corresponding alignment stability studies were performed in order to assess the risk associated with transatlantic travel of a fully assembled cryomodule. Shock loads were applied to the cryomodule by using a coldmass mockup to prevent subjecting actual critical components (such as the cavities and input couplers) to excessive forces. Accumulative and peak shock loads were applied through over-the-road testing and using a pendulum hammer apparatus, respectively. Finite Element Analysis (FEA) studies were implemented to define location of instrumentation for transport studies and provide modal frequencies and shapes. Shock and vibration measurement results of transport studies and stabilization techniques are discussed.

INTRODUCTION

The transport from Fermilab to Deutsches Elektron-Synchrotron (DESY) signifies the first overseas cryomodule shipment, providing an opportunity for advanced study. Cryomodule transport design acceleration criteria were initially established by considering the Spallation Neutron Source (SNS) transport [1]. A transport analysis completed by Babcock Noell regarding TTF style cryomodules found that the shock limits for the input coupler (IC), perpendicular to the antenna, must be less than 1.5 g [2]. During the Fermilab transport studies, a shock limit criteria for testing was established as 4 g (vertical), 5 g (transverse) and 1.5 g (longitudinal).

Two configurations of 3.9 GHz cryomodule shipment to DESY were considered: as individual components or as a fully assembled cryomodule. Transport studies have shown that shipment of a fully assembly cryomodule is viable. However, the cryomodule assembly would not only need to survive the shipment, but also maintain a stringent pre-transport alignment.

A 3.9 GHz cryomodule consists of four dressed 9-cell niobium superconducting radio frequency (RF) cavities. The coldmass hangs from two column support posts constructed from G-10 fiberglass composite, which are

attached to the top of the vacuum vessel. The helium gas return pipe (HeGRP), supported by the two columns, act as the coldmass spine supporting the cavity string and ancillaries. Brackets with blocks on two sides provide a connection between each cavity and the HeGRP. Two aluminum heat shields (80 K and 5 K) hang from the same two column supports. The coldmass consists of all components found within the 80 K shield shown in white (Figure 1).

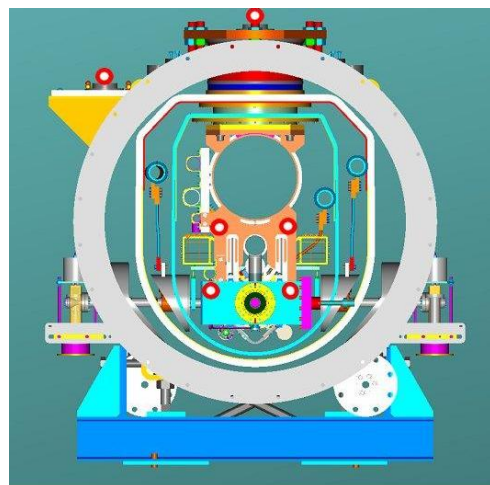

Figure 1: End view of cryomodule solid model.

Transport and Alignment Strategy

Only a combination of transport modes is possible for transatlantic shipment. Rail and ship transport was ruled out, since shock and vibration loads with such modes are quite large [3]. Therefore, our initial studies have focused on shock and vibration associated with aircraft and truck transport. SNS cryomodules have been successfully transported via air ride truck from Thomas Jefferson National Accelerator Laboratory (JLab) in Newport News, Virginia to Oak Ridge National Laboratory in Tennessee [1]. The transport studies described within this paper consider the established shock limit criteria, maintenance of relative alignment and modes of transport.

TRANSPORT ASSEMBLY DESIGN

The system shown in Figure 2, weighing 5,443 Kg is relatively stiff and slightly under-damped with isolation which reduces shock, vertically, transversely and longitudinally by a factor of roughly 2. Helical coils (or cables) loaded in tension and rotated at 45 degrees, separate the isolation fixture from the base frame [4].

* Operated by Fermi Research Alliance, LLC, under Contract No. DE-AC02-07CH11359 with the U.S. Department of Energy.

[#] mcgee@fnal.gov

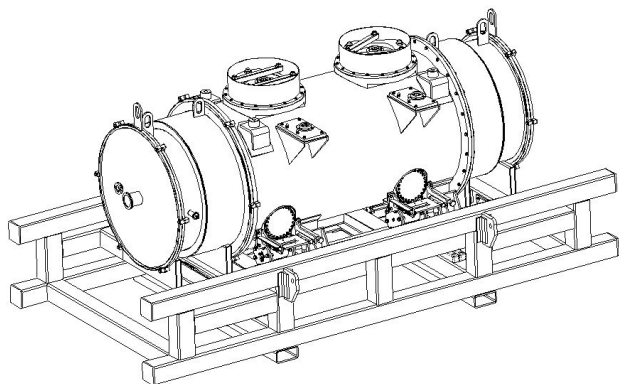

Figure 2: Cryomodule transport assembly.

Coldmass & Cryomodule Mockup

A combination of composite plastic (REN471) and stainless steel were used to closely simulate the coldmass: dressed cavities, interconnect bellows and beam valves (at each end) in a model form, shown in Figure 3. Special alignment panels, two per cavity were used for relative optical measurement to an external reference. Two intersecting wires cross along the diagonal, one cross hair per cavity provided a target. The alignment panels have a two-fold function: assist in initial assessment of transport stability studies and provide an efficient means for post-transport survey.



Figure 3: Special alignment panels (found on both sides).

Special transport design features emerged from the transport studies; vertical constraints that secure the two column supports, composite dampers with positive stops prevent motion at the beamline level, transversely at ICs longitudinally at the beam valves. Also, special attention to detail regarding torque values was observed during assembly.

Geospace HS-1 geophones and commercially available accelerometer DAQ packages (SENSR GP1 and ShockWatch "Shocklog") were used to determine peak shock, relative motion and the corresponding frequencies [5]. The geophones, GP1 and Shocklog devices were cross calibrated by applying shock randomly. Only the GP1 and Shocklog devices will escort the actual transport. Three geophones in vertical, transverse and longitudinal

axis were mounted onto each cavity with three geophones in a similar configuration also attached to the isolation fixture and base frame during the transport studies. Six National Instruments (NI) 4 channel modules with 24-bit resolution connected to a laptop were used to capture the geophone data at a sample rate of 5K/sec.

Transport Modes

Handling operations such as transfers, loading and unloading must be preplanned and closely monitored, as accidents and miss-handling can cause significant load levels (reaching between 35 to 40 g, such as with forklift operation) [6]. Special handling systems (e.g. roll-on and roll-off designs) lead to very low load levels. Typical crane and cable systems have a maximum vertical acceleration of 0.6 g. Even when loads are dropped suddenly with a crane, inherent design properties limit the vertical acceleration to 0.94 g [7].

During flight, sources of excitation are random in nature. Spatially distributed over the surface of the aircraft, these sources include; aerodynamic forces applied to the structure by surrounding air, such as gusts, aerodynamic (flutter and buffeting) and acoustic excitation [6]. At low frequencies, beneath 15 Hz air cargo does not respond dynamically as the aircraft frame experiences steady inertial loads (or accelerations) when excited by gusts, maneuvers and landing impact [8].

TRANSPORT STUDIES

The effects of shock and vibration are important from both a perspective of protection and maintaining alignment. Four periods of testing have involved both over-the-road studies and peak shock testing at the base. The final frame design evolved through both local testing on the Fermilab site and trips to Chicago's O'Hare Airport using an air ride step-back flatbed trailer and truck. The fourth and final period of testing was completed in June 2008 as three studies of the cryomodule mockup were considered. This final phase involved the evaluation of all updates to the frame, suspension system, vertical constraints and composite dampers.

Results

The results given are representative of several similar transport studies, reaching speeds > 100 Km/hr on the interstate. Absolute longitudinal acceleration and de-acceleration of the truck was measured using a GPS unit. No correlation was found between measured absolute acceleration/de-acceleration of the truck and peak longitudinal acceleration values reported from geophone, GP1 and Shocklog data. GP1 device data provided a peak value of 1.9 g at 0.17 s pulse length, which will be used as an input for IC drop testing.

A histogram of geophone acceleration data, given each sample was produced, then integrated providing a probability (or distribution) for maximum. A subsequent fit of the slope and extrapolation to 1 and 8 hour periods is given in Figure 4. For example, in 8 hours of travel one

peak acceleration event on the base frame will occur, 3.7 g vertically, 3 g transversely and 1.3 g longitudinally. Given the shock attenuation through the isolation system over the same period, the isolation fixture experience a peak acceleration event of 1.9 g vertically, 0.8 g transversely and 0.7 g longitudinally.

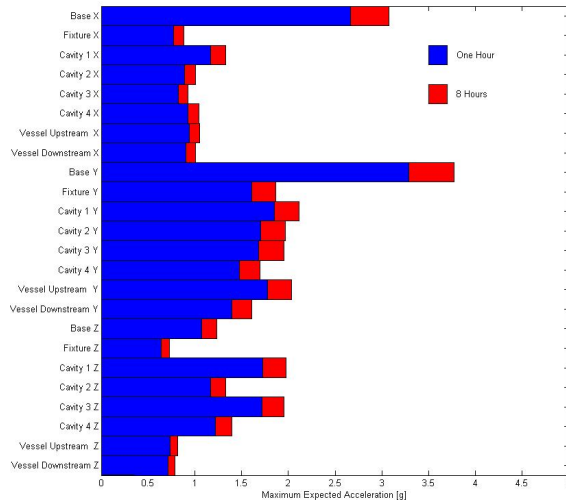

Figure 4: Extrapolated integrated probability.

The maximum acceleration on each cavity is generally equal to or beneath the isolation fixture values, except for the longitudinal case. Longitudinally, only cavity #2 is constrained rigidly to the column support system and the other cavities are connected through the Invar rod and interconnect bellows, therefore experiencing higher loads.

ALIGNMENT STUDIES

The standard local coordinate system was invariant to deformations. It is a right-handed system, with the origin at the upstream post survey monument and the following axis orientation: the Y axis (axial) passes through the two posts survey monuments (along the cryomodule pointing downstream), the Z axis (vertical) is normal to the posts plane and pointing upward and the X axis (transverse) is orthogonal to the other two axes and pointing toward beam right looking downstream cryomodule.

An API Laser Tracker was used in conjunction with a precision optical levels and precision optical alignment telescopes. All the referencing points on the vessel and coldmass were measured each epoch with the Laser Tracker and with optical instrumentation. The network was processed as three-dimensional trilateration (with distances derived from Laser Tracker observations), and supported by precision leveling. The relative errors obtained between reference control points were below ± 0.1 mm at 95% confidence level throughout the network.

Overall alignment tolerance requirement for a cold cryomodule within the TTF/FLASH accelerator at DESY is 0.5 mm. The maximum tolerance for alignment and cavity movement during shipment was 0.25 mm, considering referencing of cavities centerline, thermal

cycling, cavity string alignment and referencing to the vessel [9].

CONCLUSIONS

The potential peak shock involved in handling is high enough where proper isolation or protection is impossible. Precautions will be implemented through supervision of the shipment, especially at points of transition.

Alignment analyses of each transport study indicate that the cavities maintain their relative alignment of 0.1 mm with respect to a straight line within the cavity string; however, the alignment with respect to the vacuum vessel is only marginal to the allowable tolerance.

The integrated probability estimated for an extrapolated 8 hour period has shown that peak acceleration events during transport will not exceed the established shock limit criteria. However, cavities #1 and #3 have exceeded this criterion by 26%. Preliminary limits will be reassessed once destructive testing of the IC is complete.

ACKNOWLEDGEMENTS

Thanks to the JLab staff, Ed Daley, John Hogan, Dan Stout, Mark Wiseman and Tim Whitlatch for their help and discussions. Special thanks to Fermilab Staff: Stewart Mitchell, Jim Wilson and Sam Jarocki for their advanced computer support and Carl Wheeler regarding transport. Profound thanks to Don Mitchell and Tug Arkan and technical staff consisting of Mark Chlebek, Jim Rife and Jeff Wittenkeller. Thanks to the Fermilab Alignment and Metrology Group (AMG) team: Glenda Adkins, Craig Bradford, Gary Crutcher, Mike O'Boyle, Gary Teafoe, Chuck Wilson and Randy Wyatt.

REFERENCES

- [1] T. Whitlatch et al., "Shipping and Alignment for the SNS Cryomodule," PAC'01, (June 2001).
- [2] G. Sikler., "Transport of Cryomodules," Babcock Noell, Wurzburg Germany, DESY EV 010-94-S1 Draft version, p. 48 (September 2007).
- [3] F. Ostrem., "An Assessment of the Common Carrier Shipping Environment," Forest Products Laboratory, Forest Service, U.S. Department of Agriculture, Madison, Wi., General Technical Report FPL 22, p. 14 (1979).
- [4] www.isolator.com
- [5] www.sensr.com
- [6] F. Ostrem, "Transportation and Handling Loads," NASA SP-8077, p. 19 (1971).
- [7] U. Carlsson, "Noise and vibration aspects on railway goods transportation," Marcus Wallenberg Laboratories, Report 050E, (2003).
- [8] U.S. Department of Defense, "MIL-STD-810F Method 516.5 SHOCK," p. 5-3 (January 2000).
- [9] V. Bocean and M.W. McGee, "Referencing and Stability Studies of the Fermilab 3.9 GHz (3rd Harmonic) Cryomodule for DESY TTF/FLASH," IWAA'08, (February 2008).