

# GENERAL ENGINEERING CONSIDERATION FOR THE 100MEV CYCLOTRON

Zhenguo Li, Longcheng Wu, Gaofeng Pan, Tao Ge, Zhiguo Yin, Shigang Hou, Zhiren Yang  
China Institute of Atomic Energy  
P.O.Box 275-3, Beijing 102413, China

## Abstract

The project of Beijing Radioactive Ion-beam Facility (BRIF) composed of a cyclotron, an Isotope Separator On-Line (ISOL) and a Super-Conductive Linear Booster (SCLB) will be built in CIAE based on the existed HI-13 Tandem.

The 100MeV cyclotron with beam intensity ( $\geq 200\mu\text{A}$ ) and compact structure feature is a main part of the new project. General engineering consideration related to the machine will be described in the paper. It contains of power supplies, vacuum obtaining, beam diagnoses and computer control.

All these items are researched and preliminarily designed trying to meet the basic specifications of the cyclotron. Those proposals will be improved and optimized until this project leads to engineering process.

## POWER SUPPLIES AND WATER COOLING

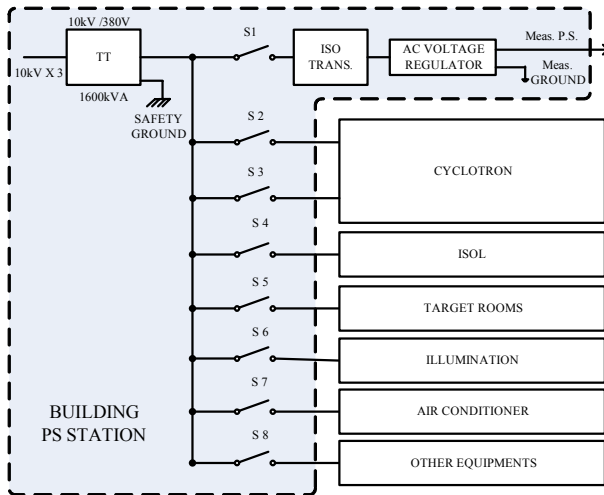

Figure 1. Layout of Power Supply

According to the general plan of BRIF project, the 100MeV cyclotron, ISOL, new experiment terminals and relevant beam lines will be located in a new building, the SCLB will be located in existed tandem building. The original power system could only be shared to SCLB, a new power system amount to more than 1000kVA needs to be set up for the new building.

The input power of 10kV is transformed to 380V, which is normally used for industry in China at master power distribution station in the building, and then leads to different equipment systems via power switches and cables. There is also a clean power system needed for

accuracy measurement devices, which is separated with the main power by an isolation transformer and stabilized by an AC voltage regulator and has its own grounding system.

The layout of the new power system is shown in Figure 1.

100MeV cyclotron is a main part of BRIF project and needs two ways of power supplies: one is for RF generator ( $\sim 270\text{kW}$ ), another goes to cyclotron power distribution ( $\sim 300\text{kW}$ ). Power distribution to sub-systems is summarized in Table 1.

Table 1: Power supply and water cooling distribution

Name of equipment	Power needed (kW)	Heat dissipation (kW)
R.F. Generator	270	145
Main Coil	45	40
I.S. and injection line	40	17
Pumps of Vacuum chamber	34	26
Beam lines	35	29
Cooling water system	105	
Others	36	15
sum	565	272

Almost a half of electric power consumed by cyclotron equipments is transferred to heat that should be taken away by cooling water. So that a circulating water cooling system needs to be installed. Cooling water is deionized to increase its resistance, usually better than  $2\text{M}\Omega\text{-cm}$ , because some equipment located at high voltage level, for example,  $\text{H}^+$  ion source at  $-35\text{kV}$  terminal. Its cooling water loop should have enough electrical isolation. Heat dissipation list of sub-systems is also summarized in Table 1.

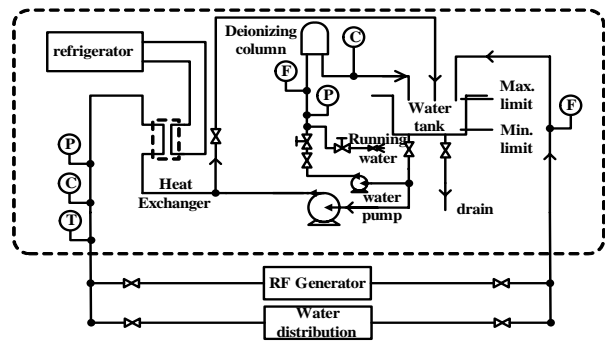

Figure 2. Schematic of Water Cooling System

Rated cooling power of circulating water system is about 275kw composed of 5 standard refrigerators with 55kw for each one. How many of the 5 refrigerators put on are decided by heat dissipation needed and controlled automatically. The schematic of water cooling system is shown in Figure 2.

## BEAM DIAGNOSES

The design of beam diagnostics system of the 100MeV cyclotron is trying to measure and to monitor the basic and important beam parameters at every stage. On the beam lines, they include beam intensity, beam position, beam profile, beam emittance and transportation efficiency. Inside the cyclotron, diagnostics include deviation of beam orbit center from the machine center, deviation of beam position from median plane, beam radial differential, beam injection and extraction efficiencies.

All these beam detectors are divided into two types: one type is non-interceptive used to diagnose beam dynamic messages when machine is at routine operation, another type is interceptive used during the period of beam test and machine tuning.

The layout of beam diagnostics is shown in Figure 3.

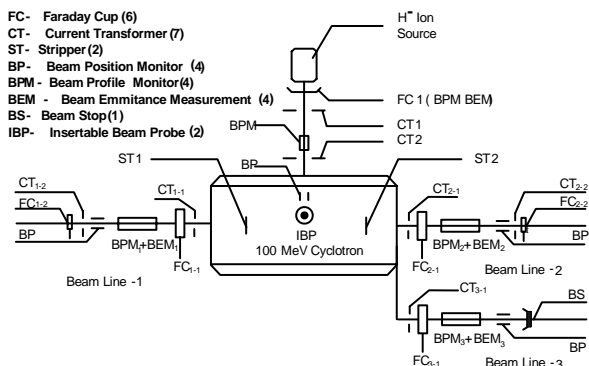

Figure 3. Layout of Beam Diagnostics

## VACUUM SYSTEM

One of the important reasons causing beam loss during acceleration and transportation is the residual gas in vacuum, especially for H-. According to the preliminary calculation, if the beam loss is controlled less than 0.5%, the vacuum in the accelerating chamber should be better than  $5 \cdot 10^{-8}$  mbar. This is a challenge requirement for a compact cyclotron, because the structure in the main chamber is very complicated. By estimate, the volume of chamber is about  $9.5 \text{ m}^3$ , the inner-surface of iron, copper and aluminum is about  $1.6 \cdot 10^2 \text{ m}^2$ . There are many openings around the chamber and O-ring seal length is about 35m, which add difficulty on obtaining high vacuum significantly.

In order to make the vacuum in accelerating chamber better than  $5 \cdot 10^{-8}$  mbar, several measures have been researched and will be adopted:

- Optimizing the design of vacuum chamber and magnet, trying the best to reduce the seal points and seal length.
- Looking for new seal materials with good vacuum property and low outgas rate and use metal seal as more as possible.
- Double-seal method will be chosen especially in some key places.
- Carefully treating and cleaning the vacuum surface to reduce outgas, baking the chamber wall and components in vacuum to speed up outgas
- No-oil pumps will be adopted to avoid oil gas backstreaming into vacuum chamber as eliminate oil contamination. Cryopumps, turbo molecular pumps will be chosen for high vacuum, no-oil dry pumps will be chosen for primary vacuum.

A planed layout of vacuum system is shown in Figure

4.

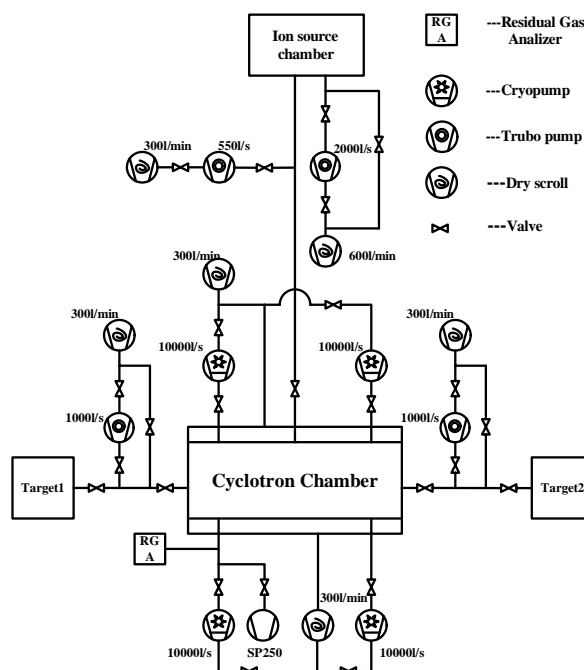

Figure 4. Layout of Vacuum System

## CONTROL SYSTEM

The control system oriented to 100MeV cyclotron, ISOL and SCLB is preliminarily designed based mainly on reliability, versatility, simplicity and standardization. PLC-based control structure used on CIAE 30MeV medical cyclotron for nearly 10 years has been proved very reliable and efficient [1] and it will come to be the major candidate for the new control system. The new development of technology both in hardware and in software will also be considered as much as possible. The successful experience for machine control in other Laboratories provide us valuable references to make the final choice.

The structure of the new control system, based on Siemens S7 series programmable controller (S7-300/400),

will adopt a widely used “standard model” [2] and consists of three layers: device control layer, front end computer layer (FEC) and operator layer.

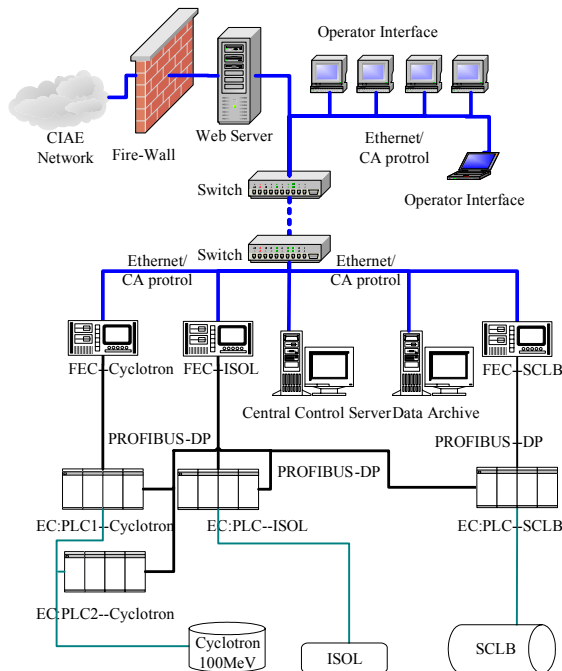

Figure 5. Structure of Control System

Device control layer consists of PLC, connected directly with machine equipments, provides controls and measurements of operation status of various devices. According to the characteristics of different sub-machines, distributed control units are used as four substations, corresponding to cyclotron, ISOL and SCLB. In this layer, between PLC station, messages are interchanged via profibus. At every PLC stations, one or more CP342-5/CP443-5 profibus modules are included to communicate with other PLC's and FEC's.

Front End Computer layer (FEC) uses X-86 series computers with windows operation system. CP5613 profibus-PCI module is installed to communicate with PLC. This layer including FEC-cyclotron, FEC-ISOL and FEC-SCLB interchanges messages between them via Ethernet. There is also a general server station designed locating in the original Tandem control room. Such arrangement gives more flexibility for operation; every FEC can operate independently or in joint manner. When joint operation of all FEC's is needed, they could be connected with the general server station. In this case, the general server station can control, coordinate and monitor the accelerator complex together.

Operator layer also uses X-86 series computer operated in Windows or Linux environment, and communicates with FEC's via channel access protocol [3].

The structure of the control system is shown in Figure 5.

Device interfaces are basic and key parts of control system. Their design principle is that one kind of device uses one kind of standard interface, e.g. the same device

interface is used to all power supplies of 100MeV cyclotron.

The hardware of PLC stations will have the same structure arrangement including the function modules; PLC sequence operation control programming will choose S7-LAD, S7-SCL or S7-Graph due to the reason that they are simple, direct, low cost, easy to understand and convenient to modify; For system coordination and communication programming, S7-STL code will be used in PLC side for it is not device related; As important parts of control program, device control function blocks will be unified and divided into two types: Function Block Type 1 and Function Block Type 2, usually the first one is used to start or stop device operation, the second one is used to condition interlock, operation status monitor and parameters acquisition and regulation.

Modularization is another characteristic of the Front End Computer control software which includes: PLC communication drive modules, system data modules, logic data modules, device control modules, control parameter modules, net data service modules and local user interface modules. All of these could provide more flexibility to the control system.

## ACKNOWLEDGEMENT

The authors sincerely thank Dr. George Mackenzie and Dr. Igor Sekachev from TRIUMF for their helpful discussion and valuable suggestion especially in beam diagnostics and vacuum system design.

## REFERENCES

- [1] Li Zhenguo, “PLC Application in the control of CIAE-30 Cyclotron”, International Accelerator and Large Experimental Physics Control Systems, (ICALEPCS '97), Section 3
- [2] B. Kuiper, “Issues in Accelerator Controls\*” Proceedings Conference on of International Accelerator and Large Experimental Physics Control Systems, (ICALEPCS '91). I3ukuba. Japan, November 1991, pp. 602-611.PI
- [3] J. Hill, “Channel Access Portable Server Reference Guide”, available at <http://mesa53.lanl.gov/lansce8/Epics/ca/casref/srvref-1.html>