

# STATUS OF THE KOLKATA K500 SUPERCONDUCTING CYCLOTRON

Rakesh K. Bhandari (for VECC Staff)  
Variable Energy Cyclotron Centre, Department of Atomic Energy, Kolkata 700 064, India

## Abstract

A superconducting cyclotron is under construction at Variable Energy Cyclotron Centre, Kolkata. The superconducting cyclotron will deliver Heavy-ion beams of 80 MeV/nucleon energy (for light ions). Fabrication and development of most of the major systems have advanced significantly. The cryostat housing the superconducting coil has been installed in the magnet structure. Installation of the cryogenic delivery line has been completed. We expect to start the cool down in late October 2004. The energization of the superconducting coil (stored energy about 22 MJ at full excitation) will start in November 2004. The radiofrequency system is under fabrication and will be delivered at site by mid 2005. The design and fabrication work of Injection line and the external beam line is in progress.

Funding has recently been approved by the government for development of elaborate experimental facilities to utilize effectively the cyclotron beams. They include a large scattering chamber, charge particle detector array, ion trap and irradiation facilities. The superconducting cyclotron will become a national facility for various universities and institutes. It will also be open to the international experimental physics community.

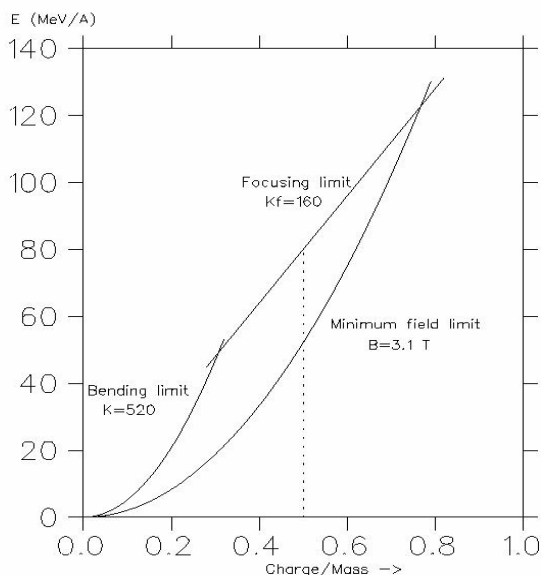

Fig.1: Energy vs charge/mass diagram for VEC superconducting cyclotron.

## INTRODUCTION

At VECC, Kolkata the K=130 cyclotron has been delivering light heavy ion beams up to 15 MeV/nucleon. The superconducting cyclotron under construction at the centre is expected to deliver up to 80 MeV/nucleon (Fig.1). The superconducting cyclotron will have  $K_{\text{bend}}=520$  and  $K_{\text{foc}}=160$ . The basic design features are similar to the cyclotrons operating at Michigan State University and Texas A&M University in USA[1,2,3]. This jump in energy is expected to satisfy the experimental nuclear physics community as a whole. This paper describes the developments related to different subsystems which have taken place.

The 80 tonne main magnet iron structure has been successfully fabricated and installed in the new cyclotron building at VECC campus. The superconducting coil was wound on the cryostat bobbin late last year using a specially developed winding set up. The liquid helium chamber housing the coil has been welded shut. The cryostat containing the superconducting coil has been assembled and installed in the magnet structure.



Fig.2: Cyclotron magnet with cryostat installed in it.

The cryogenic delivery system both for LHe and LN2 for the main magnet cryostat have already been fabricated and installed. The 200W (at 4.5K) helium liquefier/refrigerator has been relocated and re-commissioned in the main accelerator building complex. Main magnet power supply along with dump resistors and

control logistics has been installed and tested in position. Trim coil power supplies are commissioned. Development of the elaborate magnetic field measurement set up is also completed. Work is also proceeding on fabrication of the intricate RF cavities that will operate at room temperature. Various groups are engaged in the development of other systems such as RF amplifiers, LHe cooled cryopanel, ECR ion source and injection, extraction, diagnostics, controls, beamlines etc.

## STATUS OF VARIOUS SYSTEMS

### Main Magnet Frame

M/s Heavy Engineering Corporation Ltd., Ranchi (about 400 km from Kolkata) have machined the main magnet iron frame in several parts. The composition of the magnet iron has been made from same heat of steel to get near uniformity of chemical composition, physical homogeneity and grain size. The magnet frame assembly has been installed in the new cyclotron building at VECC campus. Magnet pier supporting systems have been fabricated, installed and levelled within 800-micron accuracy. Then the pole base has been mounted on the pier supports. Figure 3 shows the lower pole cap mounted on the pier supports in the cyclotron building. Lower pole tips have been installed on the pole base and levelling achieved within specified tolerance.



Figure 3: Pole tips installed on the pole base.

### Superconducting Coil

Winding of the main superconducting coil on the bobbin made from SS316L was completed in September 2003 as per specifications. The coil winding was done in-house using an automatic winding setup developed based on our conceptual design by a reputed vendor. Strict quality control was enforced during coil winding. NbTi multifilamentary composite superconducting cable ( $I_c = 1030$  A at 5.5 Tesla and 4.2 K), consisting of 500 filaments of 40 micron diameter embedded in copper matrix was used. The characteristic details of the coils are given in the table 1.

**Table-1**

$\alpha$ coil	No. of turns/coil	1084
	Total Length (km)	5.7
	ID and OD (mm)	1521 and 1793
	Inductance (H)	13.8
$\beta$ coil	No. of turns/coil	2234
	Length (km)	11.7
	ID and OD (mm)	1521 and 1793
	Inductance (H)	27.6

### Cryostat

The cryostat is now assembled in the cyclotron building and has been placed on the magnet structure. Necessary cryogenic instrumentation such as LHe level sensors, temperature sensors, strain gauges etc. have been installed inside the LHe chamber. This chamber has been insulated with multilayer insulation and LN2 cooled radiation shield assembled around it. The current leads, refrigeration lines and vent lines have also been welded to the LHe chamber and insulated. Finally, the whole insulated assembly has been welded inside the iron vacuum chamber (so called Coil Tank). Median plane penetrations for several extraction and diagnostic elements have been positioned and welded. After the final assembly, helium leak test has been performed and then the cryostat assembly have been installed in the magnet frame.



Fig 4: Cryostat bobbin with multilayer insulation and LN-2 cooled radiation shield.



Figure 5: Final assembled cryostat without median plane inserts.

### *Cryogenic Delivery System*

The cryogenic delivery system will supply cryogenes, i.e., liquid helium and liquid nitrogen to the main magnet cryostat and the cryopanel used for evacuating the acceleration chamber. The design of the cryogenic delivery system was done in-house. The vacuum jacketed and liquid nitrogen shielded transfer lines have already been fabricated and tested successfully at manufacturers' site and now installed in the cyclotron building.

Other major components such as PLC control system, liquid helium and liquid nitrogen valves, instrumentation components etc. have been procured. Various sensors for this cryogenic system, viz., temperature, level, pressure, strain, vacuum and their measuring units have already been tested thoroughly.

### *Radiofrequency System*

The RF system has frequency range from 9 to 27 MHz and the maximum dee voltage attainable would be about 100 kV. Some of the RF cavity components such as panels, moving short, contact fingers, drive mechanisms etc. have already been fabricated/ purchased by the Centre for Design and Manufacture at BARC, Mumbai in consultation with VECC engineers. Other major components such as the inner and outer conductors, dee shells, liners etc. are under fabrication. The electronics

part of the RF system is being developed in-house at VECC. Most of the major components like power tubes, amplifiers, diagnostic equipment etc. are now available with RF group at VECC. The PCBs for various circuits have been designed and are in the process of getting fabricated.

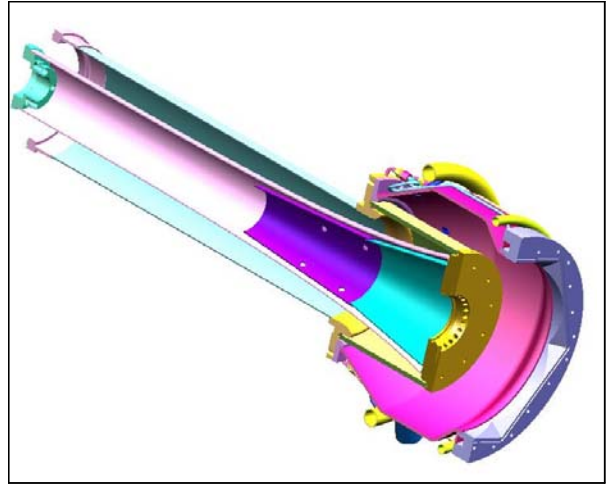

Figure 6: Computer generated model of inner and outer conductor of RF resonator with cooling lines.

### *Trim Coils*

All the 78 trim coils, made of water-cooled copper conductor, have been wound successfully. Two trials of vacuum impregnation with epoxy resin for inner pole tip have been made. In order to improve on the shortcoming of impregnation process, it has been decided to make one more trial of vacuum impregnation with outer coil. Finally, after field measurements, the trim coils will be mounted on the pole tip and then vacuum impregnation will be done with epoxy resin and re-assembled.

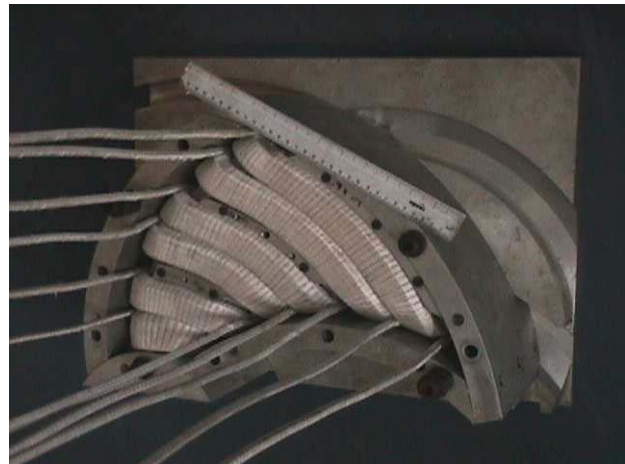

Figure 7: Trim coils wound on pole-tip

### *Magnetic Field Measurement System*

The magnetic field measurement set up has been developed, both in house (for extraction region) and by a manufacturer (for the acceleration zone). Extensive measurement of magnetic field and its harmonics has been planned to evaluate the errors and its correction. Accelerator physicists are developing codes for processing and analysing the measured field data. To correct for the field imperfections, if any, and to find out the operational parameters of the cyclotron for efficient beam acceleration and extraction, the orbit tracking codes, developed at MSU and VECC, will be used

### *Ion Source, Injection and Central Region*

In addition to the 14 GHz ECR ion source already operating at VECC, an indigenously designed ECR ion source (14 GHz) has been fabricated. Various elements of the injection beam line are under construction.

At the beginning the cyclotron will be operated in 1<sup>st</sup> harmonic mode. The maximum possible dee voltage will be used to minimize the orbital path length. The accelerating electrode structure in the central region of the cyclotron has been designed. In figure (\*) three orbits are shown corresponding to starting time 240, 255 and 270 degrees, for  $Z/A=0.357$ ,  $B_0=35.04$  KG, ion source extraction voltage 20 kV, extraction energy (E/A) ~35 MeV/nucleon and  $V_{dee}=75$  kV. Other ion species with various extraction energies and beam with finite emittance are being studied.

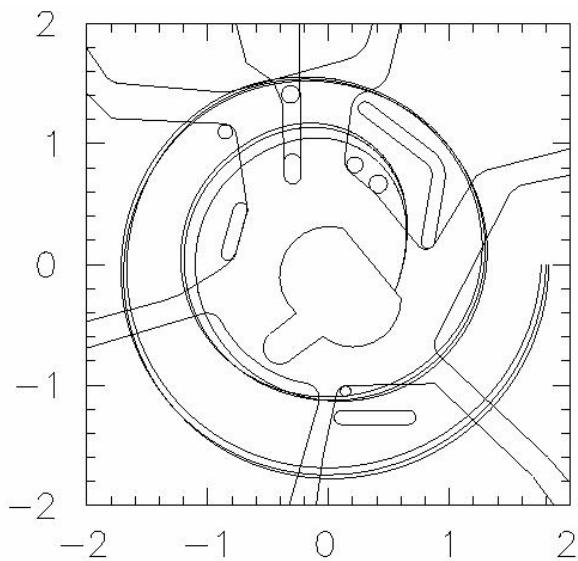

Figure 8: The central region electrode structure for 1<sup>st</sup> harmonic mode of operation (scale in inches).

### *Power Supplies*

The 10 ppm class power supply for the main coil along with dump resistors has been installed in position after elaborate tests using a dummy load. The control logistics have been developed by our engineers and tested.

Eighteen trim coil power supplies have also been tested and installed in the cyclotron building basement area.

### *Extraction System*

The extraction system consists of two electrostatic deflectors, eight passive magnetic channels, one active channel and compensating bars. The active magnetic channel involves major design change as compared to the Texas K500 machine. Detailed calculations of the beam dynamics through the extraction system have been done and minor modification may be done after field measurement. Two magnetic channels will be possible to withdraw from the beam path as it was necessary to introduce free parameters to take account of variations in the beam envelopes at different excitations. After the magnetic field mapping some fine design changes may have to be made for the channels.

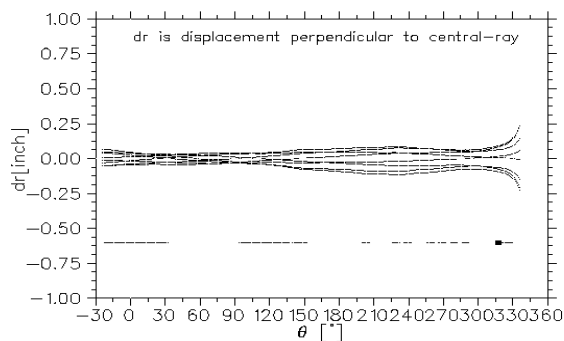

Figure 9: Beam envelope through the extraction region.

### *Control System and Beam Diagnostics*

The beam diagnostics inside the cyclotron will comprise of the main probe having three finger probe and a differential delta-R. another probe will carry a borescope for viewing the beam. The magnetic channels will have current read on them to help in extraction optimisation.

All the technical systems of the cyclotron will be computer controlled. We are planning to have a distributed control system connected through ETHERNET LAN. Mostly PCs with Windows and UNIX based systems will be used. A number of single and multi-tasking applications have been developed. Those are being tested with the existing cyclotron. Developmental work in the area of capacitive as well as scintillation detector phase probes and image digitisation has been carried out.

### *Beamlines and Experimental Facilities*

The layout of the experimental area is shown in the figure 1. Preliminary design calculations on the beam steering and phase space matching, immediately after the extraction of beam from cyclotron, have been carried out.

The external beam transport system uses two bending magnets to reduce the dispersion coefficients to a certain

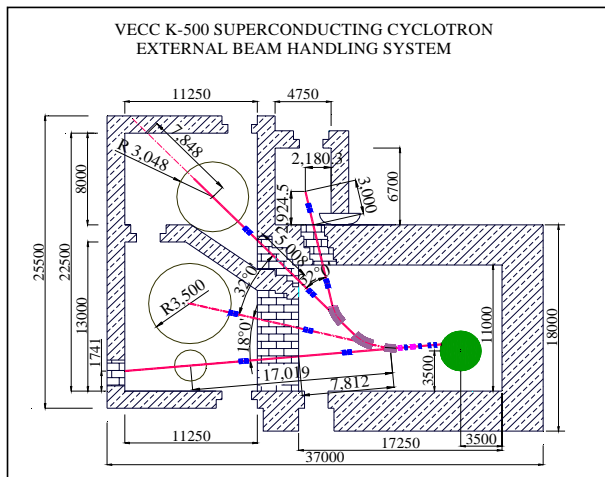

Figure 10: Beamlines layout for the superconducting cyclotron at Kolkata

extent. The ion optics beyond the second bending magnet is telescopic in nature.

Experimental facilities planned for the superconducting cyclotron include a large multipurpose scattering chamber, a  $4\pi$  charged particle array, high energy gamma detector array etc. Several national groups are working on the development of these experimental facilities.

## ACKNOWLEDGEMENTS

Construction of the superconducting cyclotron is teamwork of several scientists, engineers and administrative staff of the centre. We are grateful to all of them for their contribution.

## REFERENCES

- [1] H.G. Blosser, "The Michigan State University Superconducting Cyclotron Program," IEEE Trans. on Nuclear Science, Vol. NS-26, No.2, April 1979, p.2024.
- [2] D.P. May et. al., "Status of the Texas A&M University K500 Superconducting Cyclotron," Proc. 10<sup>th</sup> Int. Conf. on Cyclotrons and their Applications, April 30-May 3, 1984, ed. F. Marti, p. 195.
- [3] R.K. Bhandari, "Status of the Calcutta K500 Superconducting Cyclotron Project," 16<sup>th</sup> Intl. Conf. on Cyclotrons and their Applications, May 13 – May 17 2001, edited by F. Marti, p. 84.