

ENGINEERING DESIGN AND FABRICATION OF X-BAND DAMPED DETUNED STRUCTURE FOR THE CLIC STUDY*

V. Soldatov, D. Gudkov, A. Samoshkin, JINR, Dubna, Russia
S. Atieh, A. Grudiev, V. F. Khan, G. Riddone, CERN, Geneva, Switzerland
A. D'Elia, R. M. Jones, University of Manchester/Cockcroft Institute, UK

Abstract

A Damped Detuned Structure (DDS), known as CLIC_DDS_A [1], has been designed for the Compact Linear Collider (CLIC) study, and is presently under fabrication. The wakefield in the DDS structures is suppressed using a combination of detuning the frequencies of beam-excited higher order modes and by light damping, through slot-coupled manifolds. The broad principles of the design are similar to that used in the NLC/GLC [2]. CLIC_DDS_A is conceived to be tested for its capacity to sustain high gradients at CERN. We report on engineering design and fabrication details of the structure. This design takes into account practical mechanical engineering issues and is the result of several optimizations since the earlier CLIC_DDS concept.

INTRODUCTION

The CLIC_DDS_A structure serves as an alternative to the present baseline CLIC design which relies on heavy damping. It operates with a 120 degrees phase advance per cell. The accelerating structure is 414 mm long and its weight is approximately 9.8 kg. The accelerating structure

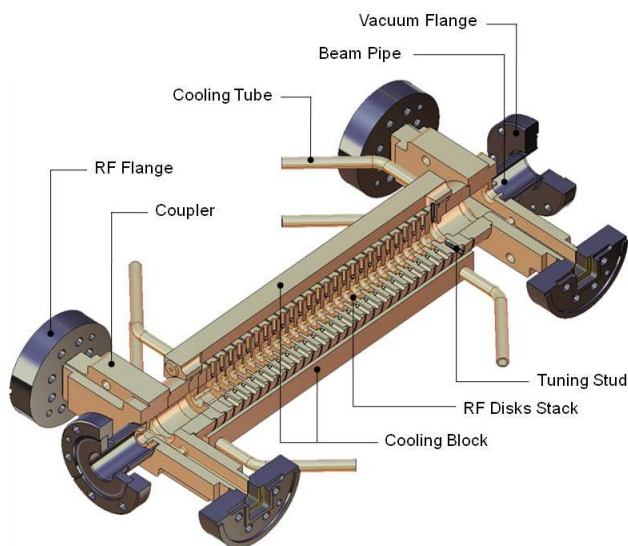

Figure 1: General view of the accelerating structure.

body comprises 24 regular cells, two matching cells as well as input and output cells. Also the full structure is equipped with couplers with vacuum and RF interfaces and cooling system. The general view of the accelerating structure is shown in Fig. 1.

ENGINEERING DESIGN OF THE ACCELERATING STRUCTURE

Engineering Design of Copper Disks

The accelerating structure body represents a stack of cylindrical copper disks, which are machined to form a cavity of the RF cells. Geometry and tolerances of cells are based on the RF requirements [3]. The basic geometry of the regular cell disk is shown in Fig. 2. The cell has an elliptical longitudinal section iris and convex elliptical cross-section outer walls. Four slot manifolds are incorporated in the cell to provide the light damping. In order to avoid burrs which could be potential breakdown sites, all edges of the disk are rounded with radius of 0.05 mm. Sharp corners of the RF volume are blended with radius of 0.5 mm. Each disk has a self-alignment feature with the nesting geometry for a reliable assembly.

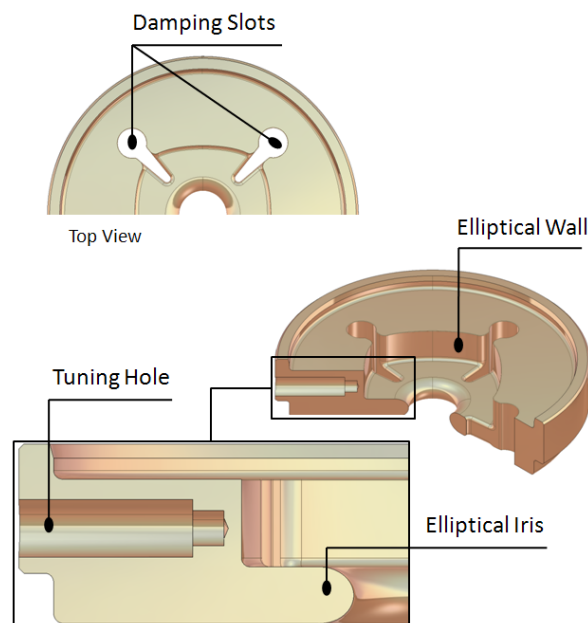

Figure 2: Regular disc cell. General view.

Although micrometer tolerances are required, each disk, forming both regular and matching cells, is equipped with four radial holes for the final frequency tuning at an approximate range of ± 5 MHz. The tuning of the RF cell

*The research leading to these results has received funding from the European Commission under the FP7 Research Infrastructures project EuCARD, grant agreement no.227579.

frequency is based on the application of a push-pull principle. Dedicated tuning studs are brazed inside each of the four tuning holes. The tuning device, linked to the tuning studs by means of a thread, deforms the disk thin wall and thus increases or decreases the equivalent outer diameter of the cell. The configuration of the tuning system is shown in Fig. 3.

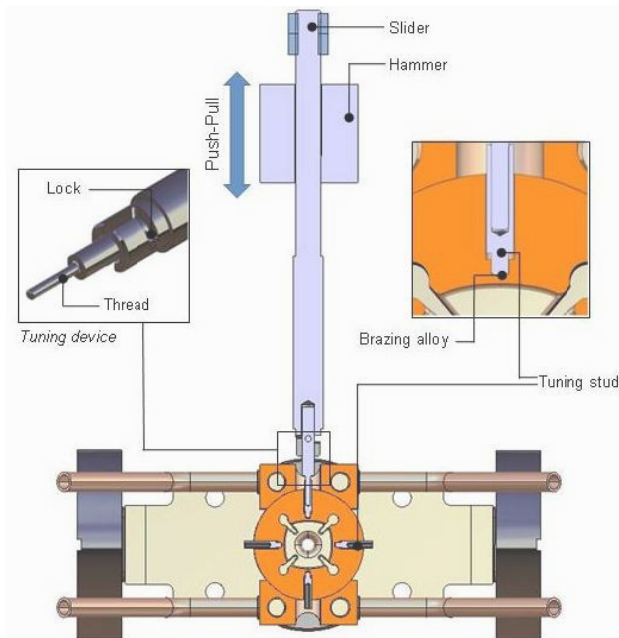

Figure 3: Tuning system of the accelerating structure.

Engineering Design of Couplers

For the RF input and output of the accelerating structure the Mode Launcher coupler is used. This type of couplers provides the highest possible electric field symmetry along with both reduced surface electric field and local surface heating.

The basic mechanical design of the coupler has been developed and applied previously for NLC/JLC

accelerating structure and used widely for the CLIC X-band accelerating structures. For the latter, a design innovation concerns the use of RF flanges newly developed at CERN. These flanges are based on a rectangular cross section OFS copper gasket and symmetrical, “knife” based design.

Engineering Design of Cooling system

In order to extract the heat dissipated during the operation of the acceleration structure, a water cooling system is implemented. The cooling system consists of two copper cooling blocks of 250 mm length (see Fig. 1). The blocks are brazed to the accelerating structure body by means of thin foil (50 μm) of brazing alloy (see details in the following chapter), providing thus a good thermal contact for an efficient heat exchange. Each block has two separate cooling circuits supplied with water through tubes of 6-mm inner diameter brazed to the inlet and outlet of the block.

FABRICATION OF THE ACCELERATING STRUCTURE

Copper Disks and Accelerating Structure Body

The disk cells are fabricated using ultra-precise turning and milling processes. The shape tolerance varies from 5 μm in the iris and cavity regions to 20 μm in the damping slot region. Flatness of the coupling faces of the disk is defined with a tolerance of 1 μm in order to fulfil the bonding requirements. Special attention is given to the transition area of turning and milling processes as the tool change creates a step. The depth of such a step is kept below 5 μm. The surface roughness varies from 0.025 μm on the disk internal surfaces to 0.8 μm on the external surfaces.

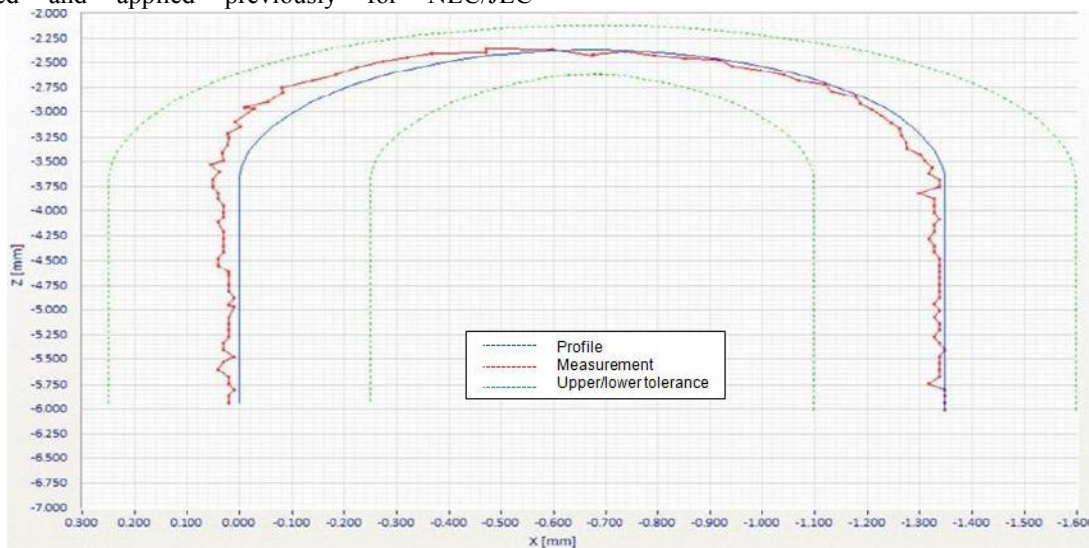

Figure 4: Shape accuracy measurements of the iris region.

As a first step for the production of the accelerating structure, four prototype disks of the same type have been fabricated by VDL ETG [4]. Prototype disks were subjected to the dimensional control at factory by using the following equipment: Zeiss UPMC 850 Carat (for dimensional and shape accuracy measurements) and Zygo NewView 5032 (for roughness measurements). The results of the inspection are very promising as the accuracy met the requirements. The most relevant results of the metrological inspection are presented in Fig. 4.

Before any heat treatment is applied, all stainless and copper parts are cleaned with specially developed procedures including vapour degreasing, alkaline soak cleaning, chemical etching, ultrasonic cleaning in de-ionized water and alcohol.

Brazing and Assembly of the Accelerating Structure

After several heat treatments, joining of the disks follows by diffusion bonding under Hydrogen and at about 1000°C. For the alignment of the disks stack the outer disk diameter of 45 ± 0.005 mm is used as a reference. The achieved assembly tolerance is lower than 10 μ m. For the qualification of the diffusion bonding, the stack of three prototype disks was used. The operation has been performed at Bodycote [5] facilities as following: outgassing and bonding at 1040°C for about 2h. The results showed a good quality of the joint as the cut inspection revealed a noticeable grain growth across the bonding plane (see Fig. 5).

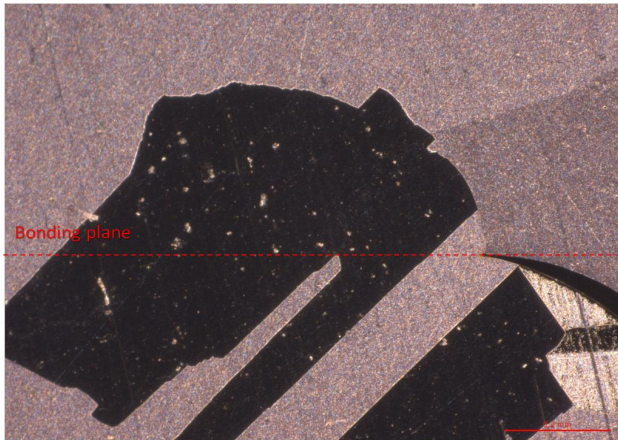

Figure 5: Metallographic analysis of the cut of the bonded disks.

Once the stack of disks is bonded and leak tightness checked, it has to be brazed to other parts and sub-

assemblies. The two main sub-assemblies are identified as couplers and cooling blocks. The coupler is brazed in two steps: the first one concerns the brazing of the coupler body at 1045°C, and then the second the brazing of the beam pipe, vacuum and RF flanges at 1035°C. For the cooling block only one brazing cycle at 1045°C is needed, allowing for joining caps and cooling tubes. For each subsequent brazing step an alloy of lower melting point is used. Typical alloys are 25Au/75Cu, 35Au/65Cu, and 50Au/50Cu. The assembly is leak-checked after each brazing step. The final brazing between disks stack, couplers, cooling blocks and tuning studs occurs at a temperature of 1020°C. Afterwards the structure is ready for RF tuning and characterization.

CURRENT STATUS AND FUTURE STEPS

To enhance worldwide collaboration, Morikawa Kanagata Co. (Japan) [6] was chosen for the manufacturing of the complete accelerating structure. The final optimization on manufacturing drawings and technology procedures has been successfully accomplished in close collaboration with KEK colleagues. The next task is the production of ten prototypes of regular disks, five of them will be selected for the dedicated RF measurements. The machining of the disks for the final structure is expected by January 2012.

ACKNOWLEDGEMENTS

The work is supported by collaboration between CLIC group (CERN), University of Manchester, Cockcroft Institute and KEK. The authors specially acknowledge T. Higo for supporting the program.

REFERENCES

- [1] V. F. Khan, A. D'Elia, R. M. Jones, A. Grudiev, W. Wuensch, R. Zennaro "Recent progress on a manifold damped and detuned structure for CLIC", IPAC10, Kyoto, May 2010, WEPE032, p. 3425-3427 (2010).
- [2] R.M. Jones, et al., Phys. Rev. STAB, 9, 102001, 2006.
- [3] V.F. Khan, et al., Nucl. Instr. and Meth. A (2011), <http://www.sciencedirect.com/science/article/pii/S0168900211011612>
- [4] <http://www.vdletg.com>
- [5] <http://www.bodycote.com>
- [6] <http://www.morikawa-kanagata.co.jp>