

# Coastal spine system - interim design report

June 2015



**Authors:** S.N. Jonkman (TU Delft), K.T. Lendering (TU Delft), E.C. van Berchum (TU Delft), A. Nillesen (D.efac.to), L. Mooyaart (RHDHV), P. de Vries (RHDHV), M. van Ledden (RHDHV), A. Willems (Iv Infra), R. Nooij (Iv Infra)

**Date:** June 20, 2015

**Version:** 0.6 (Final Draft)





## Table of contents

1. Introduction .....	1
2. Design assumptions and hydraulic boundary conditions .....	4
2.1. Protection level and design service life .....	4
2.2. Hydraulic boundary conditions.....	5
3. Bolivar Roads storm surge barrier .....	8
3.1. Introduction .....	8
3.2. Barrier in the navigational section .....	8
3.3. Barrier in the environmental section .....	12
4. San Luis Pass storm surge barrier .....	16
4.1. Introduction .....	16
4.2. Location .....	17
4.3. Barrier solutions .....	17
5. Land Barrier .....	18
5.1. Introduction .....	18
5.2. Boundary conditions and design assumptions .....	18
5.3. Land barrier design.....	19
5.4. Discussion .....	24
6. Cost estimate of the coastal spine system .....	25
6.1. Introduction .....	25
6.2. Bolivar Roads storm surge barrier .....	25
6.3. San Luis Pass Barrier.....	26
6.4. Land barrier .....	27
6.5. Coastal Spine system cost estimate .....	28
7. Conclusions and recommendations .....	30
8. List of references.....	31
Appendices .....	33
A: Design assumptions and boundary conditions .....	34
B: Scour protection design .....	38
C: Environmental section .....	51
D: San Luis Pass.....	59
E: Land barrier .....	63
F: Cost estimate .....	72
G: Technical recommendations .....	81

## 1. Introduction

The Galveston Bay area is at significant risk from hurricane-induced flooding. Over the past years the concept of the Coastal Spine (also named Ike Dike) has been developed as a solution to reduce flood risks for the region. The main aim of the coastal spine is to limit the inflow of hurricane surge into the Galveston Bay and thus protect Houston, Galveston and other communities around the bay.

The aim of this report is to synthesize the design work that has been done on the Coastal Spine system and provides an indicative and preliminary estimate of the costs of the system. Figure 1 presents an overview of the system and its main elements as discussed in the chapters in this report. The barrier includes storm surge barriers in the Bolivar Roads inlet and San Luis Pass. The total length of the coastal spine in Figure 1 is 94 kilometers (58.5 miles), consisting of 90 km (56 miles) of land barriers and 4 km (2.5 miles) of storm surge barrier. 20 km (12.5 miles) of the land barrier, along the Bluewater Highway, is still optional and added to provide a closing solution. Also, the eastern end of the land barrier near the community of High Island has to be determined and this section is therefore dashed as well. The exact length and layout will have to be optimized in future investigations.

The main function of these barriers is to prevent inflow of the hurricane surge into the bay through these inlets. The designs have been based boundary conditions for navigation and environmental flow as to minimize impacts on these functions. Other important elements of the system are the land barriers, which aim to prevent and limit overland flow into the bay. Various initial design concepts for the land barrier have been explored based on requirements for engineering performance and landscape integration.



**Figure 1: Overview of the main elements of the coastal spine**

The various chapters in this report present more information on the design assumptions and hydraulic boundary conditions (chapter 2), storm surge barriers in the Bolivar Roads (chapter 3) and San Luis Pass (chapter 4), and the land barrier (chapter 5). A preliminary and indicative cost estimate is included in chapter 6, and main findings and recommendations are summarized in chapter 7. General information aimed at a general audience with interest in the coastal spine is included in the main report. More technical information is included in the appendices.

The reported designs are mostly at a first sketch (e.g. land barrier) or conceptual level (e.g. components of the Bolivar Roads barrier). Therefore, there are still many questions and uncertainties related to aspects such as costs, feasibility and engineering performance of some of these ideas. Substantial additional design and investigation efforts will be required to come to more detailed and fully implementable designs. Findings from these future investigation and design steps could be used for further optimization and in some cases lead to changes in the initial concepts presented here.

Various groups and individuals have contributed to the designs presented in this report. Important contributions were made by students from Delft University (Civil Engineering, dep. of hydraulic engineering) who have evaluated elements of the Ike Dike as part of their Master thesis or project assignments. Designers with experience in the field of storm surge barriers in the Netherlands and other regions were involved in various design steps. Experts

from Delft University, Royal HaskoningDHV, IV Infra and D.efac.to have contributed this report.

This report complements other work and publications on the coastal spine system, including the "Game plan / framework for flood risk reduction Houston Galveston Bay" (2015) and several technical design reports on the Bolivar Roads storm surge barrier. An overview of relevant reports on aspects of the coastal spine is included in the list of references.

### **Context: The coastal spine and other strategic alternatives**

The coastal spine is one of the possible risk reduction strategies for the region based on the concept of shortening the coastline. Other strategic alternatives for the region include inner bay protection along the perimeter and mid-bay protection. These other alternatives have not been explored further in this report, but elements and findings from the coastal spine design will be relevant for these alternatives as well. Eventually, due to the complex nature of the storm surge in Galveston Bay (hurricane induced surge on the coast combined with local wind set up in the bay) it is expected that an optimal strategy would likely include multiple lines of defence, including structural and non-structural interventions. As part of these broader investigations, building with nature solutions, such as wetlands and oyster reefs within the bay, and local storm surge barriers around the Galveston Bay perimeter are being investigated in other studies.

## 2. Design assumptions and hydraulic boundary conditions

### 2.1. Protection level and design service life

A protection level and design service life has to be chosen as a basis for the engineering design. The protection level is generally expressed by means of a probability of exceedance of design conditions that the system should be able to withstand (just) safely. The corresponding hydraulic boundary conditions are used as a basis for designing the various elements of the coastal spine.

The extreme hydraulic boundary conditions (return periods water levels and off shore waves, approximately 2,000 m (6,600 ft.) off the coast) in the Gulf of Mexico near Bolivar Roads are presented in Table 1, based on hydraulic modelling in previous studies (Jin et al., 2012, Lendering et al., 2014). Further information is provided in appendix A.

**Table 1: Hydraulic boundary conditions 1/100, 1/1,000 and 1/10,000 yr<sup>-1</sup> in Gulf of Mexico**

	1/100 yr <sup>-1</sup>	1/1,000 yr <sup>-1</sup>	1/10,000 yr <sup>-1</sup>
<b>Maximum surge [m]</b>	5.2m	6.1m	7.0m
<b>Wave height H<sub>s</sub> [m]</b>	5.0m	5.7m	6.3m
<b>Wave period T<sub>p</sub> [s]</b>	7.2s	7.7s	8.2s

In this initial phase of the design, pragmatic choices for protection levels have been made as outlined below. Further optimization of protection levels will be required in future phases.

#### Storm Surge Barrier

The storm surge barriers will be built for a design service life of 200 years, corresponding with the design service life of other storm surge barriers (e.g. the Eastern Scheldt barrier in the Netherlands). A structure such as a storm surge barrier is difficult to adapt, which is why a robust design is required. Considering the long design lifetime, low adaptability and robustness required for the storm surge barriers a higher protection level (e.g. 1/1,000 per year or 1/10,000 per year) is a logical choice. Previous studies have assumed a 1/10,000 per year protection level (Lendering et al., 2014). This report will continue to build on these earlier studies of the storm surge barrier, assuming a design protection level of 1/10,000 years.

#### Land barrier

The land barriers will be built for a design service life of 100 years. The required safety level for the land barriers is based on the current elevation and safety level of the Galveston Sea Wall. With an elevation of about 17ft (5.2m) it provides an estimated 1/100 per year protection level. In addition, it is required that the land barrier can withstand significant overflow and overtopping – as its main function is to limit inflow into the Galveston bay. Reasons why a higher protection level, as chosen for the storm surge barriers, is not recommended are explained below:

- Raising the level of protection of the land barrier above a 1/100 per year protection level will require large modifications to the existing sea wall (length 16km), which will add significant extra costs to the project.



- The land barrier is more adaptable than the storm surge barrier, because the design and construction is less complex than a storm surge barrier. The structure can therefore be adapted/reinforced to satisfy higher protection levels at a later time.
- The design service life of the land barriers is 100 years, which is shorter than the design service life of the Storm Surge Barriers. A shorter service life can be chosen because the land barrier is more adaptable than a storm surge barrier.
- Also for more extreme events (e.g. 1/1000 per year) the land barrier could contribute to limit overland flow into the Galveston Bay.

To support future cost benefit analysis of different protection levels, we will briefly explore the effects of higher protection levels and resilience on the design of the land barrier.

### Future work

Pragmatic choices for initial design have been made here. In future work, further investigation and optimization of protection levels is highly recommended based on statistical analysis of historic surge data and storm frequency analyses. This can be done based on the consideration of a so-called cost benefit analysis or economic optimization. In such an approach the additional costs of better protection vs. risk reduction benefits are considered and optimized.

## 2.2. Hydraulic boundary conditions

The hydraulic boundary conditions in regular, every day, conditions are presented in Table 2. These conditions are provided for the end of the service life of the coastal spine (2115). A sea level rise of 1 meter (3.3 ft.) is included in the prediction, following De Vries (2014), who compared three sources of sea level rise for the Gulf of Mexico. A more rigorous analysis is recommended. A storm surge barrier in Bolivar Roads will partly restrict the tidal exchange between Galveston Bay and the Gulf, which will increase tidal flows through Bolivar Roads. The increased flow due to partial closure of the Bolivar Roads inlet are also shown in Table 2.

**Table 2: Regular hydraulic boundary conditions, see appendix A for further details**

<b>Low tide (MLLW)</b>	<b>0.90 m [NAVD88+m]</b>
<b>Mean Sea Level (MSL)</b>	1.15 m [NAVD88+m]
<b>High tide (MHHW)</b>	1.54 m [NAVD88+m]
<b>Significant wave height (<math>H_s</math>) in the Gulf</b>	$H_s=0.5\text{m}$
<b>Peak wave period (<math>T_p</math>) in the Gulf</b>	$T_p=4.0\text{s}$
<b>Maximum flow velocity through Bolivar Roads due to restriction of the inlet [m/s]</b>	Closure 0%: 1.0 m/s
	Closure 40%: 1.3 m/s
	Closure 60%: 1.6 m/s

The hydraulic boundary conditions for the extreme conditions, occurring during a hurricane, are summarised in the table below. The water levels are determined with respect to the current mean sea level and include a sea level rise of 1 meter over a 100 year period. The conditions for the land barriers and the storm surge barriers have a different return period (1/100 and 1/10,000  $\text{yr}^{-1}$  respectively) corresponding protection levels determined in section 2.1.



The 1/100 surge levels are estimated based on expert judgment, d.d. 21-4-2015, and previous modelling results (Rippi, 2014). The 1/10,000 year conditions are based on a technical note by Mooyaart, van den Berg and de Vries (2014). After comparing these levels with preliminary research results (Sebastian and Dupuits, to be published 2015) using Bayesian network modelling for Galveston Bay, we conclude that these are reasonable estimates.

The estimates for the fore runner surge height are based (Stoeten, 2013) who developed a simplified model which couples meteorological forcing with hydrodynamic response is used to provide a first-estimate of storm surge within simplified semi-enclosed bays. The fore runner surge levels found are considered conservative assumptions. Further statistical modelling is recommended to determine more accurate estimates of the fore runner surge for different return periods. For comparison purposes, Sebastian et al (2014) studied the surge levels from Ike and concluded that the fore runner surge for a category 5 storm which makes landfall at San Luis Pass would result in a fore runner surge just under 3 meter.

The off shore wave conditions are based on Jin et al (2010), Tables 8 and 12. The 1/100 per year wave conditions are based on a category 3 hurricane and the 1/10,000 year are based on a category 5 hurricane. These assumptions need to be re-evaluated with existing data obtained by Jackson State, especially since the wave conditions have a large impact on the design of the land barrier and corresponding cost estimates.

**Table 3: Hydraulic boundary conditions for the year 2115 (includes 100 year SLR), see appendix A for further details (H<sub>s</sub> = Significant wave height, T<sub>p</sub> = peak wave period)**

	<b>Bolivar Peninsula (1/100 yr<sup>-1</sup>)</b>	<b>Bolivar Roads (1/10,000 yr<sup>-1</sup>)</b>	<b>Galveston Island (1/100 yr<sup>-1</sup>)</b>	<b>San Luis Pass (1/10,000 yr<sup>-1</sup>)</b>
<b>Maximum water level in Gulf [MSL+m]</b>	5.2m	7.0m	5.2m	7.0m
<b>Minimum water level in Galveston bay MSL+m]</b>	Not required for design	-1.0m	Not required for design	0.0m
<b>Positive head [m]</b>	Not required for design	8.0m	Not required for design	7.0m
<b>Maximum forerunner surge [MSL+m]</b>	3.0m	4.2m	3.0m	4.2m
<b>Waves on Gulf side</b>	H <sub>s</sub> =5.0m T <sub>p</sub> =7.2s	H <sub>s</sub> =6.3m T <sub>p</sub> =8.2s	H <sub>s</sub> =5.0m T <sub>p</sub> =7.2s	H <sub>s</sub> =6.3m T <sub>p</sub> =8.2s
<b>Waves on Bay side</b>	H <sub>s</sub> =2m T <sub>p</sub> =5s	H <sub>s</sub> =3m T <sub>p</sub> =6s	H <sub>s</sub> =1m T <sub>p</sub> =4s	H <sub>s</sub> =1m T <sub>p</sub> =4s

In addition to the bad case shown in the table (high surge on the coast, low level in the bay) a so-called negative head situation has been considered in the design. This corresponds to a situation in which the water level in the bay is higher than the ocean level. This is due to the effect of rotating storms. For the Bolivar roads barrier a negative head of 3 m (10 ft.) is assumed, for San Luis Pass a negative head of 2 m (6.6 ft.) is assumed.

**Reflection on the hydraulic boundary conditions**

The hydraulic boundary conditions were compared to results of FEMA analysis (FEMA, 2012). Based on the comparison, it is concluded that the hydraulic boundary conditions in this paragraph are consistent with those derived by FEMA. There are some minor differences, which result from the uncertainties of the studies at this phase. The FEMA numbers do not vary significantly along the Texas coast, which is also consistent to the hydraulic boundary conditions derived in this paragraph. Many estimates associated with expected hydraulic boundary conditions will be better informed after ADCIRC modelling and related work is completed. Data of Jackson State have been received in a later phase of the presented study, and could be used in later stages of the project to improve the analysis of hydraulic boundary conditions.

### 3. Bolivar Roads storm surge barrier

#### 3.1. Introduction

This chapter discusses the Bolivar Roads storm surge barrier design. The barrier consists of two sections: a navigational section with the main requirement of allowing a free passage for ships, and an environmental section for water and environmental flows. See Figure 2.

In earlier design steps it has been proposed to build a floating barge gate in the navigational section and caissons with lifting gates in the environmental section. The sections below give an overview of the most important design aspects. For the barge gate in the navigation section, an additional design of the required scour protection has been made. For the barrier in the environmental section new design alternatives are discussed at a conceptual level.

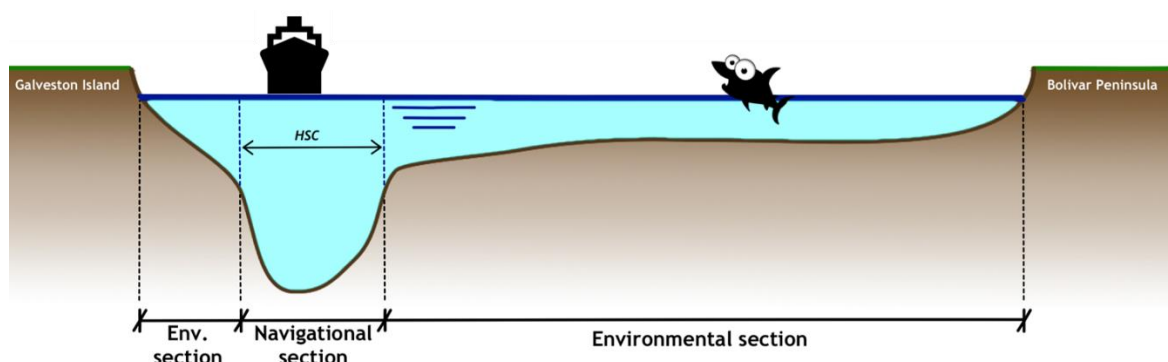

Figure 2: Bolivar Roads storm surge barrier

#### 3.2. Barrier in the navigational section

In this paragraph the design of the navigational section of the storm surge barrier at Bolivar Roads is presented. The design of the barge gate in the navigational section was studied by the barrier team in previous technical reports (sources: technical report 1, 2 and 3). Furthermore, the barge gate dynamics have been studied by Smulders (2015) and the hinge system was studied by Karimi (2014). The width of the navigational section together with the general storm surge barrier design and scour protection are discussed below.

The width of the navigational section is based on the traffic intensity and the dimensions of the design vessels traveling through Bolivar Roads. In the report of de Vries (2014), a study is carried out to find the required dimensions of the navigational section. The design vessel is a Post/New Panamax tanker, with a design draft of 15.2 m (50 ft.), a design width of 49 m (161 ft.) and a design length (LOA) of 366 m (1200 ft.) (Benitez, 2009). According to the PIANC method (2014), a nautical section with a width of 220 m (722 ft.) would be sufficient. A single, two-way shipping lane is sufficient to deal with the traffic intensity (de Vries, 2014). These requirements are used in this report.

##### Storm surge barrier design

The barge gate is designed as a partly floating structure that distributes loads towards the sides. The main reason to distribute the loads to two supports at both sides of the gate, instead of to a sill on the bottom, is to avoid having to transfer the large horizontal forces to the low-quality subsoil in Bolivar Roads. It is expected that there is not enough friction

between the gate and the sill, or between the sill and the subsoil, to successfully distribute the large loads to a sill only (Jonkman et al., 2014a). Figure 3 displays the barge gate of the navigational section and its closing procedure.

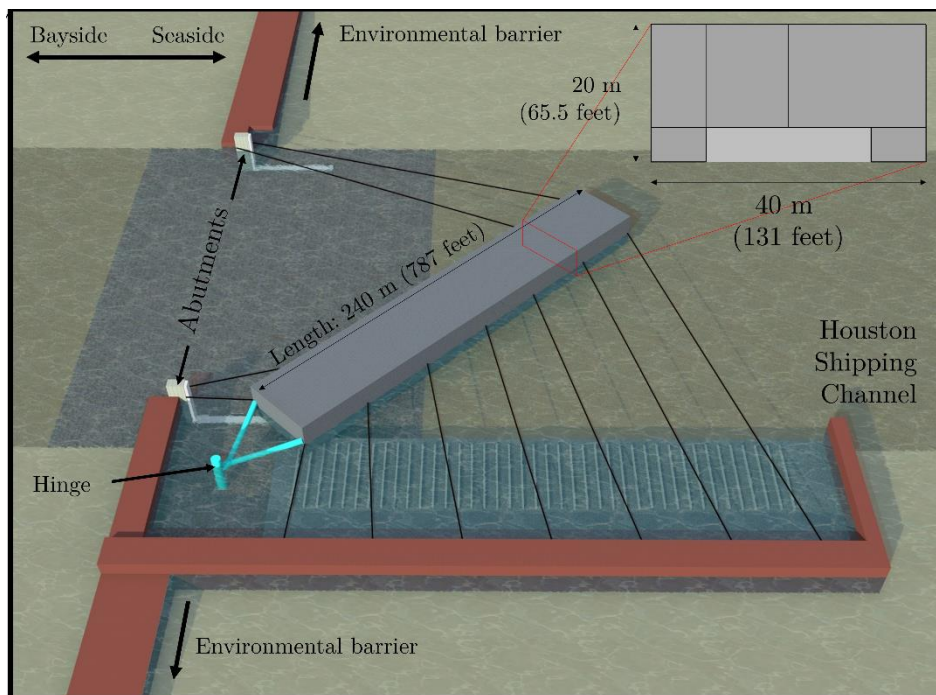

**Figure 3: Barge gate (Smulders, 2015)**

A section of the barge gate is displayed in Figure 4. A structural design in steel has been made (van der Toorn et al., 2014) and the gate consists of S355 steel and the weight is approximately 32,000 tons.

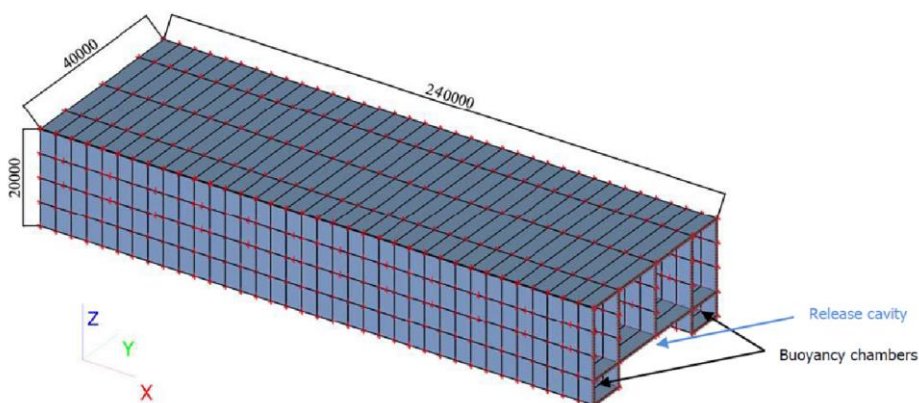

**Figure 4: Impression of the structure of the barge gate (van der Toorn et al., 2014)**

A floating barge is chosen because of the advantages of a simple sill structure and the automatic opening of the gate when a negative head occurs (higher water level at the bay than at the Gulf). Also, settlement differences of the sill are not a (critical) issue (Jonkman et al., 2014a).

Previous studies have addressed several aspects of the navigation barrier. The gate is supported by two concrete abutments. The foundation of the abutments was briefly discussed in (Toorn, et al. 2014) and is proposed to consist of a deep pile foundation with a mixed group batter piles (tension and pressure) or a deep foundation of (pneumatic) caissons or (a coupled pair of) cellular cofferdams. Based on additional soil data a design decision can be made for the most appropriate foundation type, given the total vertical reaction forces computed. The thesis of Smulders focussed on the dynamics of the barge gate in various conditions. This has shown that most movements are within tolerable limits. Critical aspects to be considered further are the landing operation and the load case under a negative head.

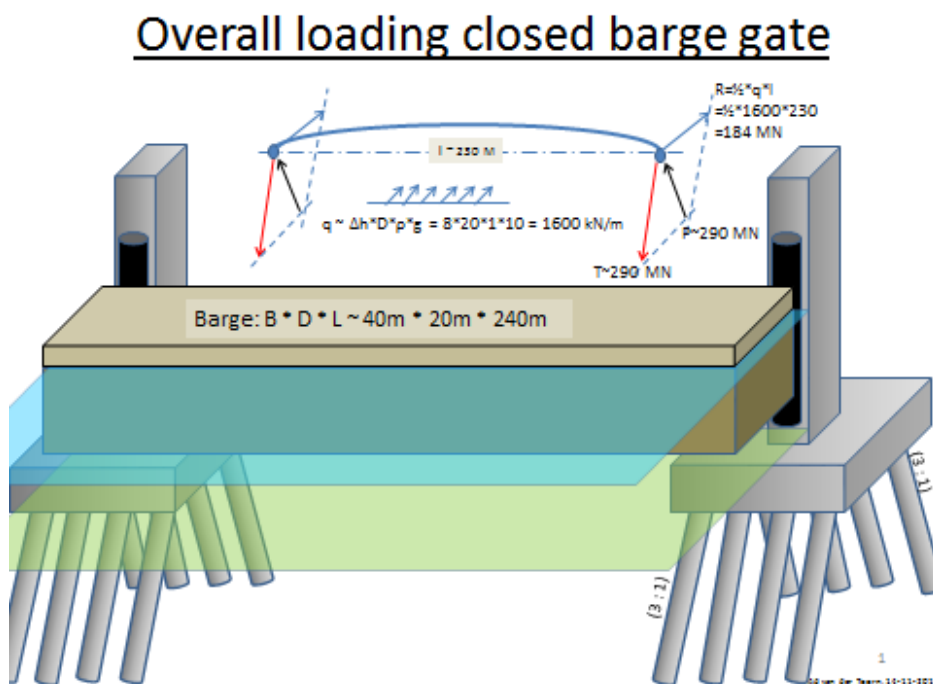

**Figure 5: Conceptual overview of the abutments and foundation (van der Toorn et al., 2014)**

The design of the barge gate was chosen to allow overtopping and overflow during hurricane conditions. Furthermore, the opening under the gate in closed position also introduces flow during hurricane conditions. Especially this opening, between the barge gate and the bottom, has negative consequences. Very high flow velocities (as a result of a large water level head during a hurricane) will occur under the gate ( $>12 \text{ m/s}$ ). This leads to a heavy scour protection which needs to consist of large concrete elements under the total gate width and large rock at both sides, according to Figure 6. Furthermore, hazardous vibrations for the gate structure can occur as a result of the high flow velocities. In Figure 6, a schematic cross section of the bed protection is displayed; more details can be found in appendix B. The stone classes are derived from Euro Norm 13383, which is also used in the Rock Manual, the nominal diameter of the stones of each class are also shown in Table 4.

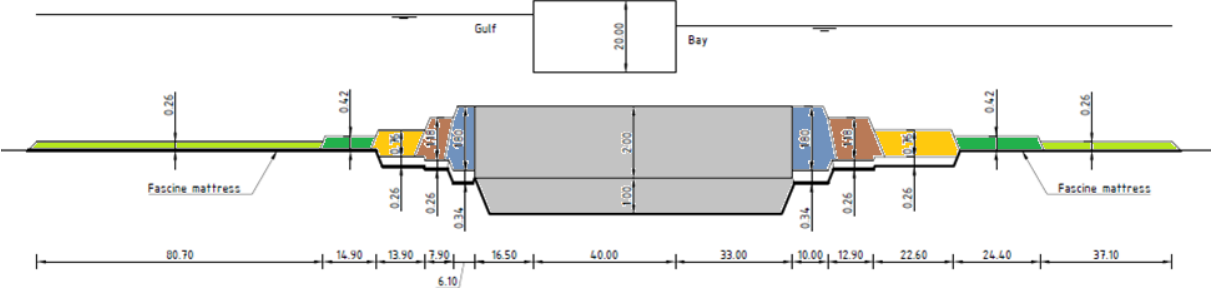

Figure 6: Sketch of the cross section of the scour protection

Table 4: Legend stone classes for scour protection

Color	Stone classes, according to Euro Norm 13383	Nominal stone diameter (m)
Grey	Concrete elements, to be designed	-
Blue	HMA 1000-3000	0.90
Brown	HMA 300-1000	0.59
Yellow	LMA 60-300	0.38
Dark green	LMA 10-60	0.21
Light green	CP 90/250	0.13

Directly under the barge gate and in the front and the back of the barge gate loose rock will not be stable. The most suitable solution for the high flow velocities are concrete elements. The dimensions of the concrete elements need to be elaborated in more detail. The main issue is that the flow depth directly under the gate is very small. The dimensions of concrete elements vary, with typical ranges of 5 x 5 x 2 m (16.4 x 6.6 x 6.6 ft.). A large number of elements are required. A disadvantage of concrete elements is the limited flexibility for future dredging and will impact future deepening of the ship channel.

This design focused on a scour protection that could fully withstand extreme surge conditions without significant damage. As a potentially cheaper alternative, a scour protection could be investigated for which damage of the protection itself is allowed, but catastrophic failure of the system is prevented. The design choice of allowing over- and underflow in closed position has a large impact on the design of the scour protection, which will result in high costs. A gate without an opening may provide advantages over the current design. The flow velocity caused by underflow will no longer be present and the (smaller) hydraulic loads due to overflow will become governing for the scour protection. These will require smaller concrete elements, which are able to follow small settlement differences. One aspect that is to be considered is whether – in case of accidental failure to close the barrier – the scour protection should still be able to handle the large flow velocities. This is a design decision that requires further investigation and optimization.

To avoid large horizontal loads, the weight of the barge can be optimized by optimizing the quantity of water in the barge. An advantage of this design is that less bending stiffness is required in longitudinal direction, which would reduce the amount of steel required. The main disadvantage is that it will not open automatically during negative heads. However, the advantage of resting the gate on a sill may outweigh the disadvantages of not automatically opening during negative heads. This requires further investigation.



### 3.3. Barrier in the environmental section

Initially, De Vries studied the design of the environmental section. His design consisted of vertical lifting doors inside caissons as a superstructure. The caissons were placed upon a foundation of vertical drainage. The feasibility of the structure was questioned in his master thesis report, as the foundation provided several major disadvantages. Moreover, solutions might be feasible with less visual disturbance than the barrier proposed by De Vries.

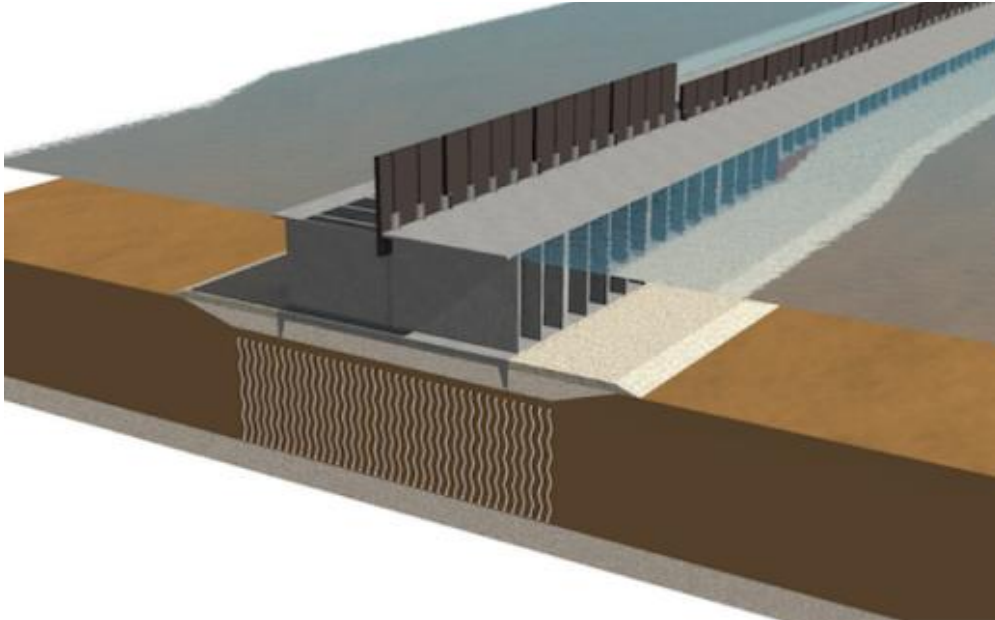
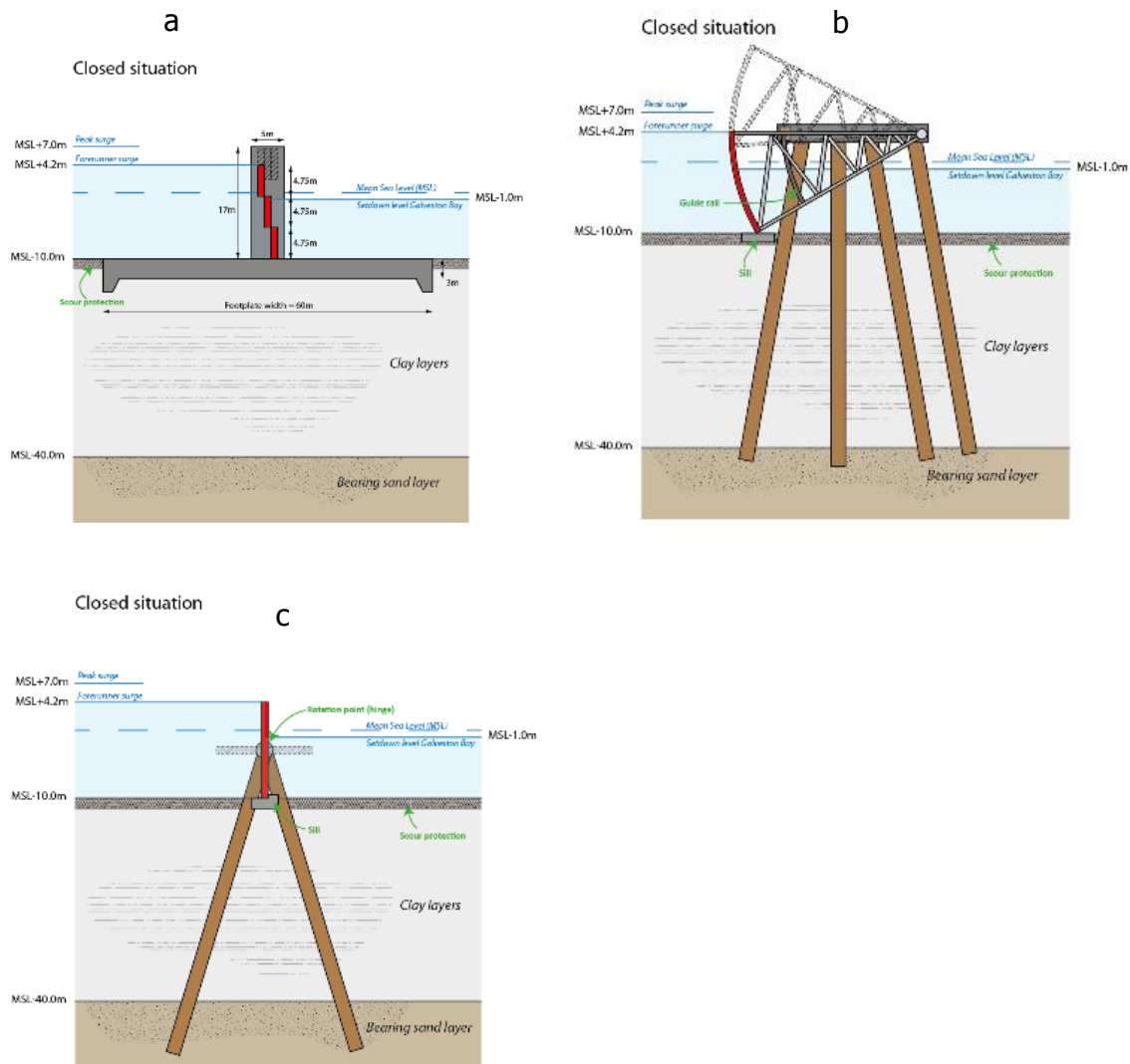

**Figure 7: Initial design of the environmental barrier in the thesis of de Vries, caissons with vertical doors (de Vries, 2014)**

Due to the aforementioned disadvantages of the design by de Vries new designs were explored at a sketch level in this phase of the barrier study, more details can be found in appendix C. This resulted in the following three concepts, which are described briefly in the following sections:

- a. Vertical lifting gates on a shallow foundation;
- b. Vertical radial gates on a pile foundation;
- c. Rotating flip gates.





**Figure 8: Cross section of environmental sketch design concepts, in closed position**

### Design 1: Shallow Foundation

This design is based on the Eastern Scheldt barrier. Here, a very thick soft layer is present similar to the situation at the Bolivar Roads. The concept is that a very wide foundation is applied, spreading the loads caused by the head over the structure. Preventing very deep foundations to allow easier construction and, therefore, reduce costs.

One of the key elements of this barrier is its *three* vertical lifting gates instead of the usual single gate. In opened situation the barriers have to be hoisted above the water level. By using three vertical lifting gates instead of one the total height of the lifting towers can thereby be decreased (see Figure 8). This is preferred to limit visibility and to a lesser extent decrease vertical loads, as the vertical lifting gates transfer the loads to the towers that are connected to a continuous footplate. A disadvantage of the lift gates is the vertical limitation, which limits the flexibility of the structure.

Taking the abovementioned aspects into account more research into the trade-off between settlements and horizontal friction capacity is required to determine the feasibility of this solution.

## **Design 2: Vertical radial gates on a pile foundation**

This design is based on the design of the IHNC barrier in New Orleans with respect to the foundation. The starting point of this alternative is that a pile foundation is applied. The barrier transfers all of the horizontal and vertical loads to the bearing sand layer at MSL-40m layer through steel tubular piles. Steel tubular piles have proven to be an excellent way in bearing heavy loads to large depths. Furthermore, this technique was applied in the U.S.; the IHNC Lake Borgne Surge Barrier in New Orleans.

Vertical radial gates are suspended on towers. The radial gates transfer the loads via the guide rail and hinge towards the pile foundation. In open situation, the entire radial gate is positioned above the water surface (including the hinge), making it easily accessible for inspection and maintenance. This pile foundation bypasses the weak clay layers and transfers all the loads to the bearing sand layer. Large (unequal) settlement of the construction is thereby prevented.

Radial gates are widely experienced movable gates. They were, for example, already used in the Haringvliet barrier in the Netherlands. In opened situation, the entire radial gate is positioned above the water surface (including the hinge), making it easily accessible for inspection and maintenance.

In Figure 8 the barrier is presented for the case when a positive head due to hurricane surge occurs. In this load case radial gates are able to effectively bear the horizontal load. The loads due to this negative head could be easily relieved by constructing valves in the gates. This, however, should be studied further.

## **Solution 3: Flip gates**

This is an innovative idea that aims to prevent that the barrier is visible during normal conditions, but it is also based on structural simplicity. Similar to solution 2, a pile foundation is applied. The two alternatives presented before both protrude above the water surface in regular conditions. Local communities in Texas would better support a solution with less visual disturbance. The entire structure, including the moveable gates lies under ebb-tide level during regular conditions.

In fact, it is a moveable retaining plate that is suspended on two steel tubular foundation piles. Similar to solution 2, the foundation piles avoid the weak clay layers and the loads are directly transferred down to the bearing sand layer. In regular conditions, the flip gate is placed in horizontal position to enable water exchange between the Galveston Bay and the Gulf of Mexico. When a high water level is expected, the flaps will be rotated around the hinge into a vertical position. The higher water pressure on the Gulf of Mexico side presses the flip gate against the sill and keeps it in this position.

The load transfer occurs via the hinge and sill down to the foundation. This sill and hinge face many challenges. A major disadvantage of the flip gate is the accessibility for maintenance, as the gates are always under water when is in open or regular conditions. The way the sill and hinge transfer these loads is yet unclear.

### **Most promising concepts**

Several possible concepts for the environmental section of the Bolivar Roads barrier have been identified in the previous sections. The most promising concepts with regard to operation, maintenance, reliability and cost seem to be a system with vertical lifting gates or radial gates. The cost estimate in this report is based on the vertical lifting gates. However, it is recommended to further design and evaluate both concepts. A different concept that could be studied would be the use of inflatable barriers, as suggested and examined by Van Breukelen (2013).

### **Scour protection of the environmental section**

The environmental section is open during regular conditions, which will result in tidal flows (see chapter 2). This environmental section will also be overtopped if a hurricane strikes the extreme design conditions are similar, but without underflow. However, cases are possible in which gates of the Environmental Barrier could fail to close. In these cases the scour protection would have to be able to handle large flow velocities to prevent undermining and failure of the entire structure. A design decision on this will depend on the type of structure chosen for the Environmental Barrier and the reliability of closure and is subject to further optimization.

## 4. San Luis Pass storm surge barrier

### 4.1. Introduction

The San Luis Pass is situated at the southern end of the Bay, as indicated in Figure 9. The San Luis Pass has a length of approximately one kilometer (3,300 ft.) and has an opening of 2000-3000 m<sup>2</sup> (22,000 – 33,000 ft<sup>2</sup>, which is 10-15% of the Bolivar Roads inlet). Surge contribution/inflow will not be very significant if you consider the current cross section. However, the flow velocities through this opening will be very high (because of the larger head difference if you close Bolivar Roads) and enormous scour can be expected if you leave this gap open during a hurricane.



**Figure 9: Top view of San Luis Pass**

Like the Bolivar Roads barrier, the San Luis Pass barrier shall affect the Bay's hydrodynamics slightly in regular conditions. We assume the same relation holds for San Luis Pass: if the flow opening in becomes less than 60% of the original, the Bay's ecosystem is adversely affected (Ruijs, 2011). After construction of a storm surge barrier the San Luis Pass should remain navigable for smaller vessels under normal conditions as a starting point. From the cross section we derive that the best navigation channel is located at the southern end of the Pass.

From this cross section we also see that the Pass is rather shallow for almost 80% of the opening, making it possible to close it off for most of its length while still satisfying the 60%/40% open/closed ratio requirement.. One solution would be to leave a navigable opening for smaller vessels with a width of around 50m and a depth of MSL -5m and an extra environmental barrier for another 150m-200m length, which is open under normal conditions. In that case the last 750m-800m of the current pass can be closed off using a permanently closed land barrier solution. This choice of closing off most of the San Luis Pass could lead to resistance of nearby residents and unwanted sedimentation. This consideration needs additional attention in the overall system optimization.

## 4.2. Location

At first thought the existing San Luis Pass Bridge is a suitable “framework” or superstructure for the barrier. However, the bridge was built shortly before 1970 though, meaning it reached a lifetime of 45 years by now. Moreover, it is highly unlikely the bridge was designed to withstand the enormous horizontal forces a closed bridge structure would face during a hurricane. Of course, better research should be done at a later stage to choose the final position of the barrier.

## 4.3. Barrier solutions

Next we take a look the barrier solutions. We find the Bridge has a horizontal clearance of 57 ft. (17m) and a vertical clearance of 29 ft. (8.7m). For reasons of reliability and maintainability a vertical lift gate is a preferable option. It can be maintained (relatively) easily since all critical parts are above sea level. It is highly reliable since it can (almost) always be closed on gravity if all other drive systems fail, if designed wisely. An interesting alternative to consider is the possible use of a sector gate, as used in New Orleans, LA.

This barrier is probably not enough to satisfy the 60% opening requirement under normal conditions. We propose to apply the same solution as for the environmental barrier at Bolivar Roads (See chapter 3 for more details) to semi-close the remaining opening of the San Luis Pass to satisfy the 60% opening requirement. The remaining 40% of San Luis Pass can be closed permanently. To avoid structures that need heavy and expensive, foundations, we propose to apply a land barrier for this part. It can be founded on the (firm) clay layer, giving the least expensive barrier with a “green look”. This combination of solutions has been illustrated in Figure 10. More detailed information can be found in Appendix D.

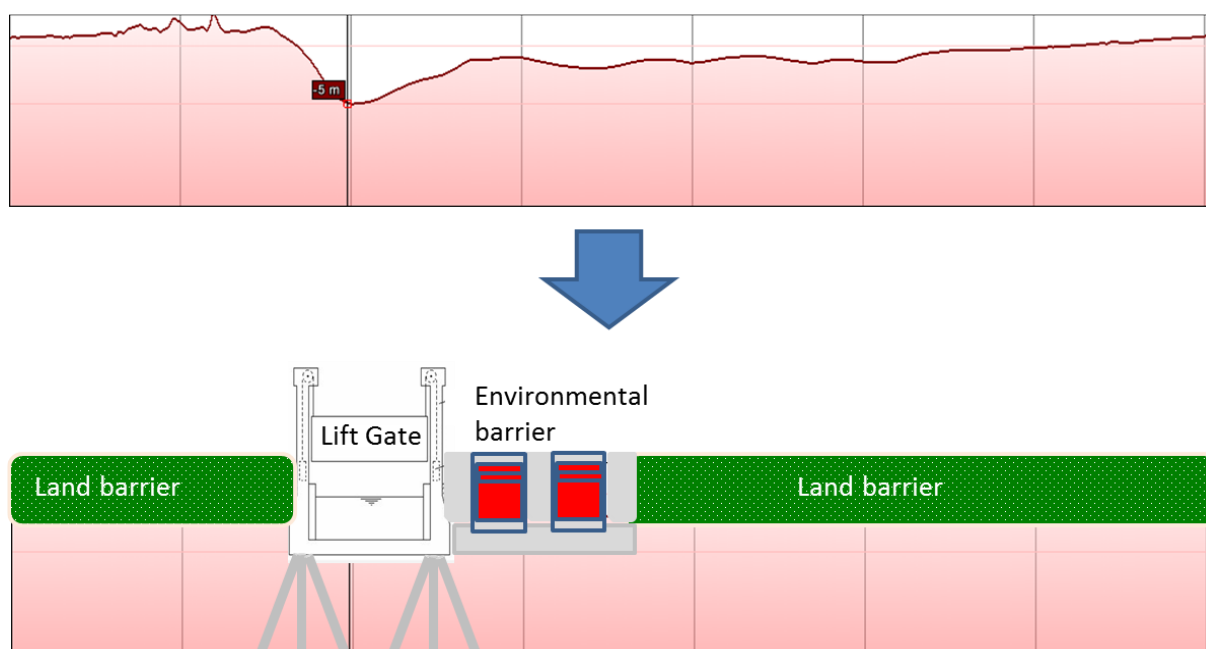

**Figure 10: Proposed San Luis Pass storm surge barrier solution**

## 5. Land Barrier

### 5.1. Introduction

The land barrier is the element of the Coastal Spine system with the largest length and a crucial part in the defense of the entire Galveston Bay Area. As most research up till now has mostly focused on the Storm Surge Barrier at Bolivar Roads, an additional initial design step has been performed for the land barrier, combining engineering and architectural landscape design.

The land barrier is located at the Bolivar Peninsula and Galveston Island, which are situated north and south of Bolivar Roads. It has been assumed that a section along the Bluewater Highway, south of the San Luis Pass is required to close off the bay. This is a conservative choice as it still optional and its necessity for surge reduction in the bay needs to be determined. This results in a 90-kilometer (56 miles) land barrier system, closing off the Galveston Bay Area from Freeport in the south up to Anahuac National Park in the north. Also, the extension and connection of the eastern side of the land barrier near the community of High Island need to be investigated in future work. Both the western- and eastern end of the land barrier have not been finally determined and are subject to further work.

To come to a well-defined concept of the land barrier on the Bolivar Peninsula, Galveston Island and along the Bluewater Highway, it is proposed to generate alternatives and choose the most suitable one as a preferred alternative for the costs estimate. It is noted that previous work (West, 2014) includes an evaluation of some land barrier concepts that are also included in this study.

The current initial design step focusses on a sketch level technical design of possible land barrier alternatives. Several crucial implementation aspects are discussed in the closing paragraph of this section. For example, a detailed analysis of the presence of existing structures within the land barrier footprint has not been performed.

### 5.2. Boundary conditions and design assumptions

The boundary conditions are based on a combination of hydraulic boundary conditions and preferences of stakeholders, as discussed with experts from Texas A&M University:

- The preferred barrier elevation is 5.2 m (17 ft.). This is equal to the existing Galveston seawall and represents the 1/100 per year maximum water level in the year 2115. The consequence of this condition is shown in Alternative 1. However, constructing on this level will result in very large amounts of overtopping during the design storm (in the order of 1000 L/m/s), resulting in destruction of infrastructure, facilities and private property on the Galveston Island and Bolivar Peninsula.
- The land barrier should be overflow/overtopping resistant without catastrophic failure during 1/100 per year conditions. The design amount of overflow/overtopping will therefore depend on the height of the barrier and the local conditions.
- A natural look or coverage is preferred.

The land barrier design will be based on 1/100 per year conditions, which results in a water level of 5.2 m +MSL and 3 m (10 ft.) waves. This wave height differs from the hydraulic boundary conditions, because higher waves are assumed to break and lose height. Explanatory calculations are added in Appendix E.

### 5.3. Land barrier design

Using rules of thumb, realistic hydraulic boundary and existing design, several concepts are possible. The first step is to generate and categorize these concepts and choose three alternatives that will be evaluated further. The broader selection of initially considered concepts can be found in Appendix E.2.

Three alternatives for the land barrier have been evaluated. These alternatives represent three different approaches to the problem and will only give an overview of how the general cross section on the three land masses may look like. These alternatives are:

1. *Continuity and History*; this alternative extends the Galveston Seawall along the islands, which results in a fitting architectural integration of the new flood defense system in the existing structures.
2. *Natural Safety*; this alternative raises the dike slightly above the 5.2 m (17 ft.) elevation in order to enable a natural look and cover along the dike possible.
3. *Seaward Protection*; the last option uses a permeable breakwater to protect the dike on land and gives way for possible wetlands at the same time.

#### Alternative 1: Continuity and History

The Galveston Seawall has protected its citizens for more than a century and stands out as a familiar landmark. To enhance stakeholder cooperation and honor this historic civil structure, the Seawall will be extended along the Galveston Island and the Bolivar Peninsula. A first impression can be seen in Figure 11.

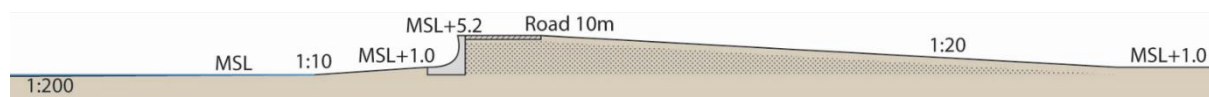

**Figure 11: Cross section of land barrier alternative 1: Continuity and History**

The main defense structure consists of a floodwall to counter the surge and waves. Behind the iconic seawall, a very gentle slope will lead the road back to normal level. Because of large overtopping, extensive ground protection is needed to ensure stability. The current design would require roughly 130 m<sup>3</sup> of sand per meter barrier (1450 ft<sup>3</sup>/ft.) and 250 m<sup>3</sup> of clay per meter barrier (2700 ft<sup>3</sup>/ft.). The total footprint is 110 meter wide (360 ft.), of which the most part can be combined with existing structures, i.e. the levee part of the land barrier could be built around the structures that are mostly raised.



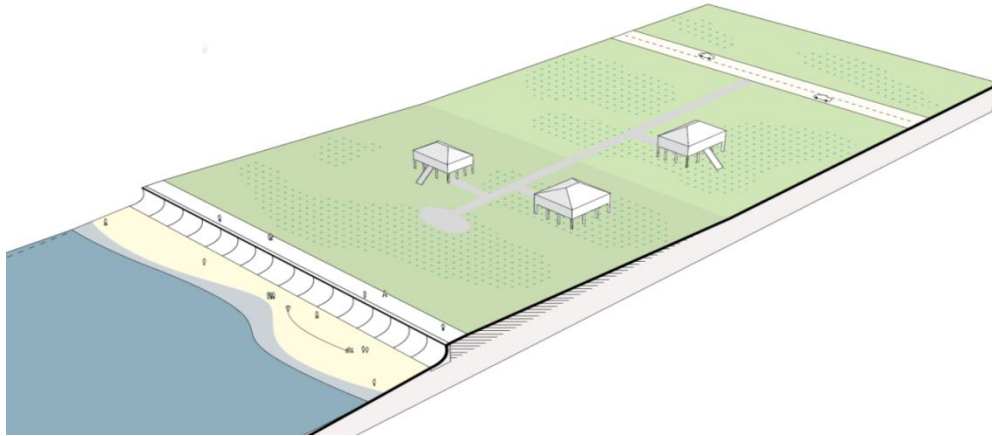

**Figure 12: Alternative 1 artist impression**

*Advantages:*

- + Relatively low dike height and gentle slope ensures minimal change in the appearance of the island/peninsula and the view of the residents.
- + Structure resembles the iconic Galveston Seawall, enhancing the continuity.
- + Gravity structure and gentle slope leads to resilient structure when large storms hit.
- + Is able to withstand significant overtopping

*Disadvantages:*

- Low dike height at design water level leads to insufficient protection from waves
- Large amount of sand needed due to gentle slope
- Expensive, non-natural inner berm protection needed to ensure stability
- More difficult to integrate with existing land use due to wide footprint

**Alternative 2: Natural Safety**

Both Galveston Island and the Bolivar Peninsula own a recognizable natural look that deserves a flood defense with the same values. This alternative raises the dike beyond the mentioned 5.2 meter up to a level where inner slope protection with a natural cover is possible. Calculations show a needed height of 7.5 meter (24.6 ft.). The outer slope does need artificial protection. However, this concrete or asphalt layer can be covered with a small layer of sand and grass to maintain the natural look. An impression can be seen in Figure 13.

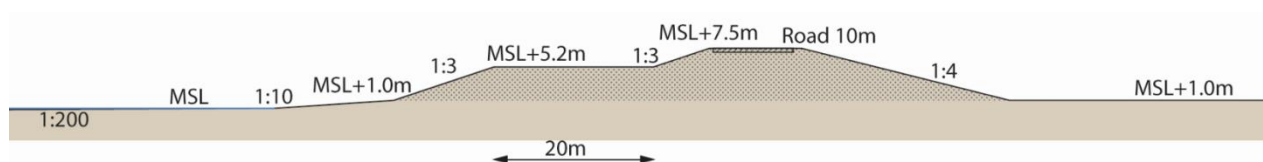

**Figure 13: Cross section of land barrier alternative 2: Natural Safety**

This sand/grass-layer will have to be replaced after a hit from a large hurricane, which will probably occur several times during its lifetime. The increased height of the dike will lead to lower amounts of overtopping, making the use of natural cover a possibility. By placing the road on top of the highest point of the dike, both the beach and the protected areas behind the dike will be easily accessible. The current design would require roughly 90 m<sup>3</sup> of sand per meter barrier (970 ft<sup>3</sup> /ft.) and 230 m<sup>3</sup> of clay per meter barrier (2500 ft<sup>3</sup> /ft.). The total

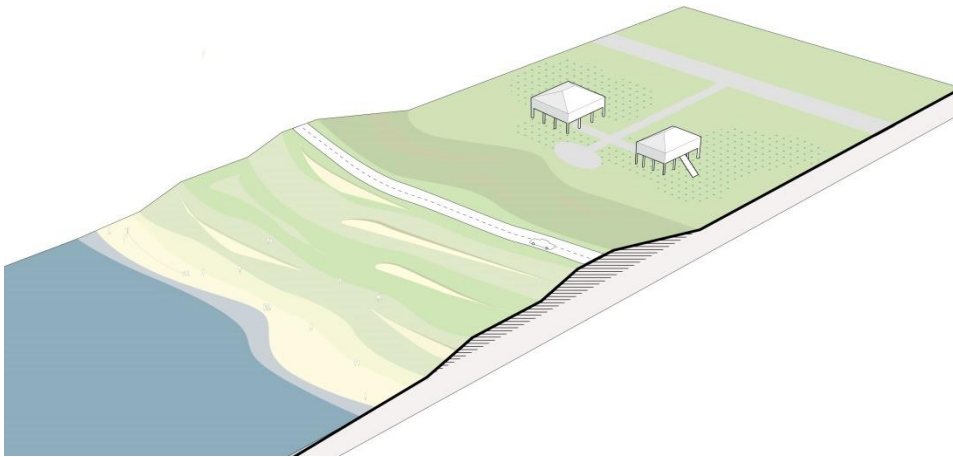

**Figure 14: Alternative 2 artist impression**

footprint is 80 meter wide (260 ft.), which cannot be used for additional purposes, other than transportation.

*Advantages:*

- + No concrete/asphalt protection needed at inner slope
- + Relatively small affected land area, focused around road (public property)
- + Outer bank protection can easily be covered with sacrificial sand/grass-layer, because of relatively low frequency of hurricanes

*Disadvantages:*

- Dike crest height above 5.2 meter (17 feet)
- Outer berm requires non-natural protection
- Large amount of sand needed for berm and dike

**Alternative 3: Seaward protection**

The third alternative focusses on a minimal alteration of the land masses themselves, with at the same time trying to maintain or even increase the natural environment that the Galveston Island and the Bolivar Peninsula allow for. Like the second alternative, the dike has to be raised up to 7.5 meter (24.6 ft.), where an inner slope with a natural cover is a possibility. To enable the use of a natural cover on the outer slope as well, the waves need to be dampened. This is done with a breakwater. An impression can be seen in Figure 15.

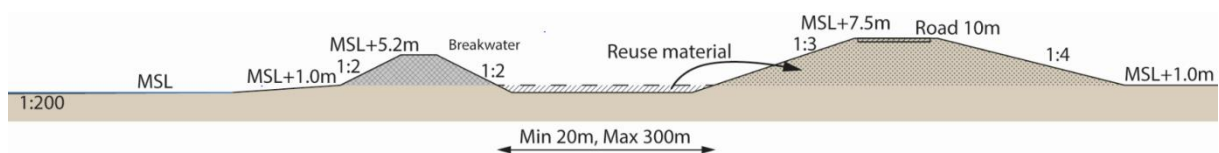

**Figure 15: Cross section of land barrier alternative 3: Seaward protection**

With the use of this combination, an opportunity rises to reuse soil from in between the breakwater and the dike of the construction of the dike itself. This will decrease construction costs. By using this soil, a low-lying piece of land appears where water can enter through the breakwater. However, waves will be dampened significantly, leading to a streak of land where the local natural environment can flourish. The beach will be relocated to the outside of the breakwater, where recreation in the sea and the waves is still possible. The current

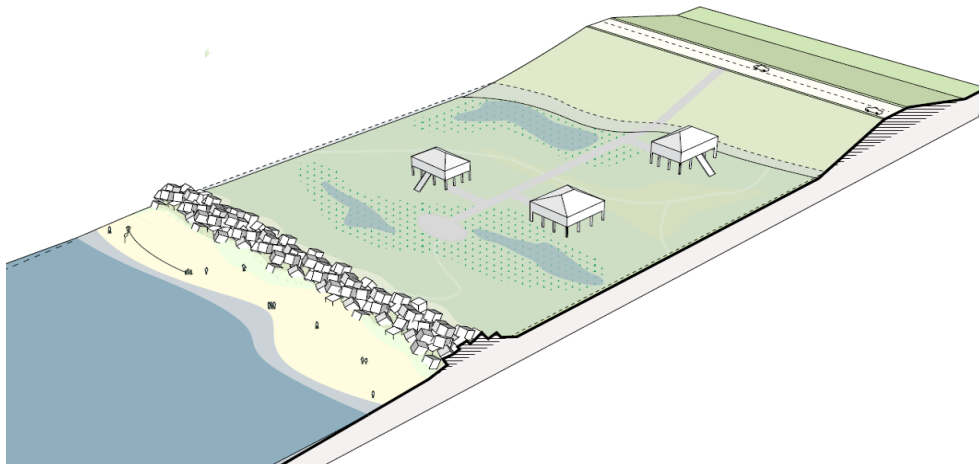

**Figure 16: Alternative 3 artist impression**

design would require roughly  $55 \text{ m}^3$  of sand per meter barrier ( $590 \text{ ft}^3/\text{ft.}$ ) and  $160 \text{ m}^3$  of clay per meter barrier ( $1700 \text{ ft}^3/\text{ft.}$ ). Also  $65 \text{ m}^3$  of breakwater is required per meter ( $700 \text{ ft}^3/\text{ft.}$ ). The total footprint can vary between 100 m and 400 m (330-1300 ft.), depending on the natural zone. This zone and the breakwater are placed outside of the current shoreline.

*Advantages:*

- + No concrete/asphalt protection needed on inner- or outer slope
- + Lower construction costs because of reuse of soil material
- + Breakwater provides first line of defense and dampens the wave attack

*Disadvantages:*

- Dike crest height above the 5.2 meter (17 feet) elevation
- Large amount of material needed for breakwater
- Additional streak of land increases distance between houses and beach

**Preferred alternative**

As can be seen from the descriptions above, none of the alternatives are able to fully comply with all of the boundary conditions. However, Alternative 1: Continuity and History i.e. the seawall with wide dike has to most potential with the current demands. The first alternative complies to the height restriction and offers a robust situation for overflow. This alternative will therefore be considered as the preferred alternative. The preferred alternative will be used and evaluated in the cost estimate and the final overview.

This alternative has been chosen because it is the only alternative that meets the 5.2 meter (17ft.) elevation restriction and has the opportunity to be improved with the use of temporary adjustments. The structural elements of the seawalls provide protection against surge and large wave overtopping volumes. To allow resilience for overtopping events, a relatively mild inner slope could be chosen as proposed in the current concept.

To enhance landscape integration, the extended floodwall could also be covered to look like a natural dune – the so-called dike (or levee) in dune concept – see Figure 17 and Figure 18. This will lead to higher costs but somewhat higher landscape value. In case of a design storm, this natural cover will vanish and the seawall will be exposed. However, because of the low frequency of this magnitude of storm, this can be an interesting adjustment to increase the natural look of the barrier. To reduce costs, it is possible to only cover the floodwall at residential and touristic areas.

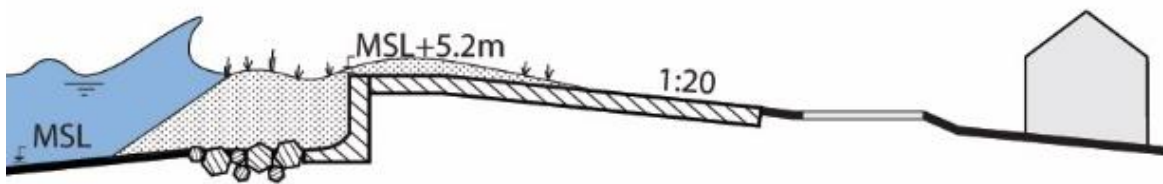

**Figure 17: Impression of the seawall alternative with dune coverage**

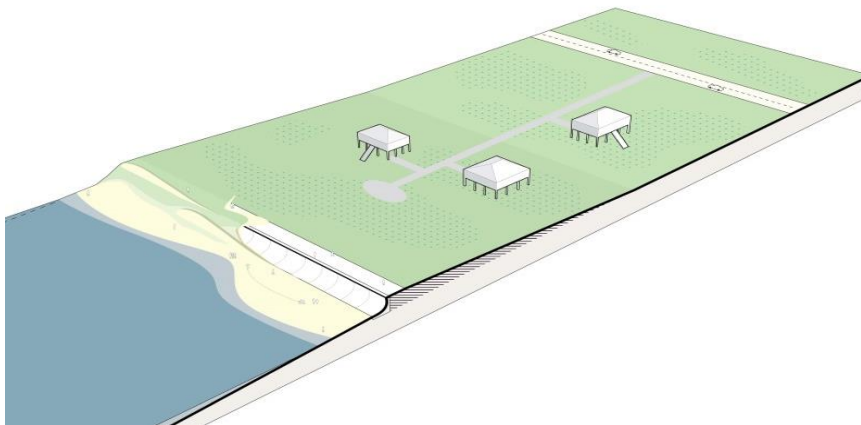

**Figure 18: Artist impression of seawall, partly covered with a dune coverage**

### **Adaptability**

The importance of the residential and industrial areas around the Galveston Bay Area could result in the requirement of a higher safety level. In the hydraulic boundary conditions the situation of a 1/10.000 per year storm is provided with this in mind. The choice of land barrier should therefore also include its adaptability to possible higher standards.

The preferred alternative can easily be adapted. The seawall can be extended to a higher level, after which the levee can be lifted. Adapting the other alternatives would lead to a larger inland footprint, as the dike crest and the total dike volume needs to be expanded. Because a concrete or asphalt layer is not required on the inner slope, this will cause no additional challenges. It can therefore be concluded that adaptation of all the alternatives to higher safety level is possible, as long as the requirement of possible expansion is added to the engineering requirements of the original flood protection.

#### 5.4. Discussion

This initial design step is intended to show the different options that can be considered when designing the land barrier. The most important conclusion is the fact that it is not possible to completely comply with all boundary conditions simultaneously. Especially the height restriction, where a dike height of 5.2 meter (17ft.) is required, will lead to a limitation of the options as large forces and overtopping rates need to be endured. The exact amount of overtopping and its consequences are still unknown and are subject to future work. This choice will result in a structural solution, consisting of a seawall with a wide levee. This solution is therefore mostly a result of the height restriction and other concepts will become more attractive if costs, rather than elevation restriction become more important.

Many of the homes on the coast will have ground floor elevations that are in the same range as the crest height of the coastal levee. If this is the case, some of the existing structures could be incorporated in the coastal dike, but this is a topic for further assessment and local design. The design of the inside slope would allow for local modification and optimization to allow existing structures to be integrated in the new coastal dike. In a next design step it is recommended to consider a few representative cross sections and to investigate how the barrier design could be adapted to account for existing structures.

A less structural looking solution can be found by increasing the maximum allowable dike height. Overall, further investigation and optimization of the land barrier is recommended. Special attention is required for the construction materials and their availability – largely affecting construction costs. Investigations could focus on the role of the overall land barrier in surge reduction in the bay and the optimization based on engineering, costs and landscape integration.

## 6. Cost estimate of the coastal spine system

### 6.1. Introduction

The Coastal Spine is an integrated protection system, consisting of storm surge barriers and three land barrier sections, connected to protect over 90 kilometer (56 mile) of Texas shoreline. Because of the large amount of factors still unknown and the current stage of design, it is challenging to make a detailed cost estimate. However, with the use of well-known design assumptions and knowledge from earlier constructions, it is possible to make a preliminary and indicative (but "rough") cost estimate

The costs will be estimated for the different elements according to two approaches: the rule of thumb- and the material based approach, which are shortly described below. More information on each element and the considerations that led towards the used costs and bandwidth can be found in Appendix F.

- Rule of thumb approach: The first cost estimate is a simple rule of thumb that is based on barrier length and utilizes a bandwidth of unit costs from previously realized storm surge barriers.
- Material based approach: The second approach identifies the main elements of the proposed barrier system and attempts to estimate typical costs of these elements by applying volumes and unit costs of materials.

The cost estimates of the two approaches will be compared and combined to come to one cost estimate of the coastal spine elements. Given the level of the design (preliminary / sketch) a bandwidth of costs is used.

The costs estimates of the coastal spine will include the elements presented in figure 1 and other parts of this report: land barrier sections, Bolivar Roads and San Luis Pass storm surge barriers. It is assumed that the Rollover pass and Bolivar Peninsula is closed in line with current planning.

The costs presented in this section include direct costs for materials and construction, but also aspects such as site costs and some small margin for unforeseen costs. These additional project-dependent costs are accounted for in the form of a percentage of the material costs. The total cost estimate and added notes are also stated in Appendix F.

In the calculation of unit prices for which sources are in Euros, the following conversion has been used: 1 Euro = 1.15 US \$. The costs presented in this section concern total construction costs but do not include long-term management and maintenance cost.

### 6.2. Bolivar Roads storm surge barrier

At Bolivar Roads, the 3-kilometer (1.9 mile) stretch will be closed off with the use of a 200-meter (660 ft.) barge gate barrier and a 2800 meter (1.7 mile) environmental barrier. In the cost estimate, this is divided in the Navigational Storm Surge Barrier and the Environmental Storm Surge Barrier.

### Bolivar Roads Navigational Storm Surge Barrier

The barge gate placed to close off the main ship lane is the most technically challenging element of the Coastal Spine and will therefore most likely be the most expensive per meter span. As the design is not detailed enough to use the material based approach, the costs of the barge gate is based upon rule of thumb.

With the use of unit costs from previous storm surge barriers around (Mooyaart et al., 2014), the costs per meter can be estimated. Due to the complexity of the barriers, the costs are high and in the range of 1 to 4 million dollars per meter span. The barrier shows relatively strong resemblance to the Maeslant Barrier in the Netherlands, as both barriers swing a large steel element in the navigation channel from the side(s) and the channels which need to be closed off, have a comparable depth (MSL-17m and -17m+NAP respectively). However, current information on Bolivar Roads show a difficult environment and leave many challenges, which will be accounted for by increasing the Maeslant barrier unit costs with 25%. This leads to a first estimate of 2.75 million dollars per meter span, which in turn results in a cost estimate of this element of 550 million dollars.

### Bolivar Roads Environmental Storm Surge Barrier

The Environmental Barrier will most likely be one of the more expensive elements of the Coastal Spine due to its long length (2800 meters, 1.7 mile). The barrier has been evaluated with both the rules of thumb- and the material based approach, which showed rather large differences. The rules of thumb-approach was based on the Eastern Scheldt Barrier (unit costs \$2.1 million per meter span), which show large resemblance to the current design of the Environmental Barrier. However, this barrier was built roughly 30 years ago and was the first of its size, which could overprice any construction based on it. The material based-approach showed a lower cost (\$0.7 million per meter) but will most likely underestimate the cost of specialized equipment for working in an environment like Bolivar Roads.

It does show that the costs of the lifting gates, the footplate and the bed protection will be leading in further assessing the best and most cost efficient alternative. For this phase, the costs for the Environmental Barrier at Bolivar Roads are estimated to be 4.0 billion dollars. The entire calculation can be found in Appendix F and Appendix F.1.

### 6.3. San Luis Pass Barrier

The San Luis Pass is evaluated as a combination of different barriers. As was made clear in Chapter 5, most of the barrier will be closed off with the use of an earthen levee. A smaller part (150 m, 490 ft.) will be designed in the same way as the environmental barrier, and there will be a section with a 50 m ( 160 ft.) lift gate for the passage of small vessels.

**Table 5: San Luis Pass barrier elements and costs**

Element	Length	Unit costs	Estimated component costs
Lift gate	50 m (160 ft.)	2.1 M\$/m	105 M\$
Environmental barrier	150 m (490 ft.)	1.4 M\$/m	210 M\$
Earth levee	800 m (0.5 mile)	17 M\$/km	15 M\$
<b>Total</b>			<b>330 M\$</b>

From the table above can be seen that the San Luis Pass Barrier is estimated to cost 330 million dollars.



#### 6.4. Land barrier

The land barrier is the longest element of the Coastal Spine. It consists of three sections:

- Bolivar Peninsula
- Galveston Island
- Bluewater Highway (optional)

Together, these three sections span roughly 90 kilometer (56 mile). The cost estimate is based on the preferred alternative, which consisted of a 5.2 meter (17 ft.) high sea / floodwall and a gentle, clay/sand inner slope.

For the area south of the San Luis Pass (the Bluewater highway section) a choice has to be made whether a land barrier is needed. If a design storm hits, the lands south of the San Luis Pass will flood, especially with the other barriers in place. It is therefore chosen to extend the land barrier in South-western direction up to Freetown along the Bluewater Highway, which adds another 20 km of land barrier protection. This is a conservative estimate and has to be investigated in further optimization, also linked to outputs of surge models. Also, the extension and connection of the eastern side of the land barrier near the community of High Island need to be investigated in future work.

Because of preliminary status of the design, no distinction between the different sections is made. That means the cost difference is solely dependent on the length of the land barrier. The barrier lengths on Bolivar Peninsula, Galveston Island and along the Bluewater Highway are 40 km, 30 km and 20 km respectively.

A land barrier is a more common structure than a storm surge barrier, which makes it easier to evaluate. The difference between the rule of thumb- and the material based method was therefore rather low. The two approaches gave unit costs of \$47.8 million per kilometer and \$40.1 million per kilometer respectively. Assuming the design as presented in Chapter 5, the total costs of the Land Barriers are estimated to be \$4.1 billion. However, the design of the land barrier itself is still in a preliminary phase, and changes to it can significantly affect the costs. In this respect it is noted that due to the chosen option (a sea wall and large earthen dike behind it) the costs are fairly high, e.g. when compared to other flood protection projects such as in New Orleans. Therefore, further optimization of the land barrier design – also based on costs would be an important topic for future work.

### 6.5. Coastal Spine system cost estimate

With the use of the above information, the costs of the different elements of the Coastal Spine are estimated. Adding these figures will lead to the total project costs. Special attention is needed when it comes to the bandwidth of costs. Different elements with a different level of detail are added. The total bandwidth on the project is based on the elements, corrected for the relative costs compared to the total.

The cost estimate shows an estimated project cost of 5.2-12.4 billion dollars. This results in an estimate of **\$8.9 billion** with a **bandwidth of 40%**.

**Table 6: Coastal Spine system cost estimate per element**

Element class	Location	Length	Unit costs	Element costs	Bandwidth
<b>Storm Surge Barrier</b>	Bolivar Roads (Navigational)	200 m	2.75 M\$/m	550 M\$	50%
	Bolivar Roads (Environmental)	2800 m	1.4 M\$/m	4,000 M\$	50%
	San Luis Pass	1000 m	-	330 M\$	50%
<b>Land Barrier</b>	Bolivar Peninsula	40,000 m (25 mile)	0,045 M\$/m	1,800 M\$	30%
	Galveston Island	30,000 m (18.6 mile)	0,045 M\$/m	1,350 M\$	30%
	Bluewater Highway	20,000 m (12.5 mile)	0,045 M\$/m	900 M\$	30%
<b>Total</b>				<b>8,930 M\$</b>	<b>40%</b>

Almost half of the total cost are associated with the Bolivar Roads storm surge barrier, which follow from the combination of a complex moveable storm surge barrier and its large length. Lower protection levels are not expected to reduce the cost of the storm surge barrier significantly, as unit costs will remain relatively high. In further research it is recommended to optimise the total cost of the coastal spine by considering different protection levels for all structures.

One should keep in mind that in this early stage of design, many factors are unknown and design can still change significantly. However, given the current phase and the knowledge on the current design elements, the results give a first indication of the range of construction costs.

The cost estimates do not include management and maintenance costs. These can be considerable, up to 1% of construction costs on an annual basis for storm surge barriers, and in the order of \$ 100,000 per kilometer per year for dikes and levees (Jonkman et al., 2013c).

As a final note, it is interesting to compare this to the costs of other large scale surge suppression systems. The hurricane protection system that was (re)built after hurricane Katrina had a total cost of about \$ 15 billion. The total costs of the Delta works are estimated at 5.5 billion Euros (Steenepoorte, 2014). If it is assumed that these were at the 1985 price levels, the current value would be more than 11 billion Euros (\$12.5 billion) in present values.

Further and more detailed estimates of costs are recommended. Optimization of costs is recommended by considering different protection levels, and alternative designs. Especially for the land barrier – which is an initial design phase – the cost could be further optimized and likely reduced. More information on (availability of) materials is required for further design.

## 7. Conclusions and recommendations

This report synthesizes the design work that has been done on the coastal spine system. Technical investigations on elements of the system (the land barrier and storm surge barriers), showed that the coastal spine is a large and technically challenging project, but a feasible one. A preliminary and indicative estimate shows that construction costs of the coastal spine are in the range of \$5 – \$12 billion (median estimate of \$8.9 billion). The costs are high, but likely justifiable given the risk levels in the Houston Galveston Bay. The designs in this report could be used for further discussion, decision-making and provide a basis for future work.

More specifically – building on earlier technical design reports – this report has provided more information on the following elements:

- The scour protection of the navigational barrier in the Bolivar Roads has been dimensioned, showing that a very large structure is needed
- A reconsideration of the gates for the environmental section showed that vertical lift gates or radial gates could be good options for further investigation
- A first sketch design of a barrier in the San Luis Pass has been presented, showing that a vertical lifting gate that allows smaller vessels to pass in combination with two smaller environmental flow gates seems a good option.
- A first sketch design of the land barrier has been presented. For the given boundary condition of a 17 ft. (5.2m) elevation, a seawall with a wide dike seems an option that can withstand the large forces and overtopping rates. Parts of this subsystem could be constructed as a levee in dune to improve landscape integration.

Most of the presented designs are at an initial sketch or conceptual level, and several further steps and investigations are recommended to get more insight in the costs and possibilities to realize a coastal spine. The recommendations are discussed in more detail in appendix G.

The most important topics for further investigation include the further optimization of protection levels of various elements of the system based on a risk-based approach. This might show that not all elements are necessary to reduce the surge in the Bay sufficiently. Also, technical aspects of the Bolivar Roads barrier need further investigation and optimization to come to a more detailed design: the foundation, scour protection and the choice of the environmental barrier. Furthermore, it is important to further optimize the proposed designs taking into other functions and aspects such as landscape integration and effects on environment, population and economy.

In addition to the engineering design, it will be key to develop a system for funding, management and maintenance of the coastal spine. A conservative cost estimate of the system has been presented assuming that all the elements are required. However, since there is a large buffering capacity on the Galveston Bay it could be further investigated if certain elements can be “left out” or reduced in elevation and thus costs. Finally, it is highly to investigate if and how the coastal spine needs to be combined with other risk reduction interventions, such as wetlands in the bay, and local barriers and gates around the Galveston Bay to come to a comprehensive flood risk reduction system for the region.

## 8. List of references

### Technical Reports/White Papers:

- Benitez, M. E. (2009). *Dimensions for future lock chambers and 'New Panamax' vessels*. OP's Advisory to Shipping No. A-02-2009
- Federal Emergency Management Agency (FEMA) (2012). *Flood Insurance Study. Galveston County, Texas, and Incorporated Areas*. Volume 1-4.
- Jin, C. et al., 2012. *Site Specific Wave Parameters for Texas Coastal Bridges: Final Report*, College Station: Texas A&M.
- Jonkman, S.N., van Ledden, M., Lendering, K.T., Mooyaart, L.F., Stoeten, K.J., de Vries, P., Willems, A., de Kort, R. (2013a). *Report Galveston Bay: Flood Risk Reduction Barrier*. Internal Report. Delft University of Technology, the Netherlands.
- Jonkman S.N., van Ledden M., Lendering K.T., Mooyaart L., Stoeten K.J., de Vries P., Willems A., de Kort R. (2013b) *Bolivar Roads Flood Risk Reduction Barrier: Sketch design*. Final draft July 19, 2013
- Jonkman, S.N., Hillen, M.M., Nicholls, R.J., Kanning, W., Ledden, M. van (2013c) *Costs of Adapting Coastal Defences to Sea-Level Rise— New Estimates and Their Implications*. Journal of Coastal Research: Volume 29, Issue 5: pp. 1212 – 1226. Coconut Creek (Florida), ISSN 0749-0208
- Jonkman, S.N., Mooyaart, L.F., van Ledden, M., Stoeten, K.J., de Vries, P.A.L., Lendering, K.T., van der Toorn, A., Willems, A. (2014a). *Reconnaissance Level Studies on a Storm Surge Barrier for Flood Risk Reduction in the Houston-Galveston Bay*. ICEE 2014: Proceedings of 34<sup>th</sup> International Conference on Coastal Engineering, Seoul, Korea, 15-20 June 2014. ISBN: 978-0-9896611-2-6.
- Jonkman S.N., van Ledden M., Lendering K.T., Mooyaart L.F., Merrell W., Willems A. (2014b) *GAME PLAN: Framework for Flood Risk Reduction in the Galveston Bay Area*. version – December 5, 2014 Working document, draft
- Lendering K.T., van der Toorn A., de Vries P., Mooyaart L.F., van Ledden M., Willems A., Jonkman S.N. (2014) *Barge barrier design: phase 3*. July 10th, 2014
- Mooyaart, L., Jonkman, S., de Vries, P., Van der Toorn, A., & van Ledden, M. (2014). *Storm Surge Barrier: Overview and Design Considerations*. Coastal Engineering Proceedings, 1(34), structures.
- Sebastian, A., Proft, J., Dawson, C., & Bedient, P.B. (2014). *Characterizing hurricane storm surge behavior in Galveston Bay using the SWAN+ADCIRC model*. Coastal Engineering, 88, 171-181. doi: <http://dx.doi.org/10.1016/j.coastaleng.2014.03.002>.
- Steenepoorte, K. (2014) *De stormvloedkering in de Oosterschelde*. Rijkswaterstaat Zee en Delta, the Netherlands.
- Stoeten, K.J. (2012). *Applying Best Practices from The Delta Works and New Orleans to Galveston Bay*. External Research Report. Delft University of Technology, the Netherlands.

van der Toorn A., Mooyaart L., Stoeten K.J., van der Ziel F., Willems A., Jonkman S.N., van Ledden M. (2014) *Barge barrier design*. Technical report February 7, 2014

West, N.A. (2014). *Conceptual Design and physical model tests of a levee-in-dune hurricane barrier*. M.Sc. Thesis. Texas A&M University, Texas, USA.

**TU Delft thesis reports on elements of the coastal spine (www.repository.tudelft.nl):**

van Breukelen, M.C. (2013). *Improvement and scale enlargement of the inflatable rubber barrier concept: A case study applicable to the Bolivar Roads Barrier, Texas, USA*. M.Sc. Thesis. Delft University of Technology, the Netherlands.

Heeringa, T., Janssen, M., Roukens, G., Kelderman, R., Gunnewijk, R., de Milliano, A. (2014) *The Bolivar Peninsula. Design of a Risk Reduction Strategy*. Master Project. Delft University of Technology, the Netherlands

Karimi, I. (2014). *The Conceptual Design of the Bolivar Roads Navigational Surge Barrier*. M.Sc. Thesis. Delft University of Technology, the Netherlands.

Rippi, K. (2014). *Bolivar Roads Surge Barrier. How to estimate the optimal barrier height after a risk assessment*. Internship Report. Delft University of Technology, the Netherlands.

Ruijs, M. (2011). *The Effects of "Ike Dike" Barriers on Galveston Bay*. M.Sc. Thesis. Delft University of Technology, the Netherlands.

Smulders, J. (2014). *Dynamic Assessment of the Bolivar Roads Navigational Barge Gate Barrier*. M.Sc. Thesis. Delft University of Technology, the Netherlands.

Stoeten, K.J. (2013). *Hurricane Surge Risk Reduction for Galveston Bay*. M.Sc. Thesis. Delft University of Technology, the Netherlands.

de Vries, P.A.L. (2014). *The Bolivar Roads Surge Barrier: A Conceptual Design for the Environmental Section*. M.Sc. Thesis. Delft University of Technology, the Netherlands.

## Appendices

Appendix A:	Design assumptions and boundary conditions .....	34
Appendix B:	Scour protection design .....	38
Appendix C:	Environmental section .....	51
Appendix D:	San Luis Pass.....	59
Appendix E:	Land barrier .....	63
Appendix F:	Cost estimate .....	72
Appendix G:	Technical recommendations .....	81



## A: Design assumptions and boundary conditions

A protection level and design service life has to be chosen as a basis for the engineering design. The protection level is generally expressed by means of a probability of exceedance of design conditions that the system should be able to withstand (just) safely. The corresponding hydraulic boundary conditions are used as a basis for designing the various elements of the coastal spine.

	1/100 yr <sup>-1</sup>	1/1,000 yr <sup>-1</sup>	1/10,000 yr <sup>-1</sup>
<b>Maximum surge [m]</b>	5.2m	6.1m	7.0m
<b>Wave height H<sub>s</sub> [m]</b>	5.0m	5.7m	6.3m
<b>Wave period T<sub>p</sub> [s]</b>	7.2s	7.7s	8.2s

**Table 7: Hydraulic boundary conditions 1/100, 1/1,000 and 1/10,000 yr<sup>-1</sup> in the Gulf of Mexico**

The 1/100 and 1/10,000 per year surge levels are estimated based on previous barrier studies by the Delft University of Technology (Jonkman et al., 2014a), these were used to determine the 1/1,000 per year surge level by logarithmic linear interpolation. Waves are estimated based on (Jin et al ,2012. Table 8 and 12). The following sections discuss the required design protection level for both the land barrier and the storm surge barrier, based on these hydraulic boundary conditions.

### Land barrier

The land barriers will be built for a design service life of 100 years. Currently the Galveston Sea Wall protects Galveston island against flooding from hurricanes. The protection level provided by this sea wall is determined based on expert judgment. The crest of the sea wall rests at +5.2m (or 17ft), which is equal to a 1/100 per year water level including Sea Level Rise (SLR). It is estimated that with a water level equal to the crest level and wave heights corresponding with a 100 year return period ( $H_s \sim 5\text{m}$ ) the Galveston sea wall will experience damage, without catastrophic failure, while providing sufficient protection for the hinterland during these (1/100 per year) conditions.

The 1/100 per year protection level is used as a basis for the first estimate of the cost of the land barrier. Reasons why a higher protection level, as chosen for the Storm Surge Barriers, is not recommended are explained below:

- The 1/100 per year protection level already results in a large amount of overtopping due to waves. Raising the level of protection above a 1/100 per year protection level will require large modifications to the sea wall, which is not preferred by the local residents.
- The design service life of the land barriers is 100 years, which is shorter than that of the Storm Surge Barriers. These structures can therefore be built less robust than the Storm Surge Barriers, because their design will be evaluated / updated sooner.
- The adaptability of a land barrier to new / updated hydraulic boundary conditions is less complex than the adaptability of a Storm Surge Barrier.

This means the land barriers are able to resist storm conditions with a return period of once in one hundred years. Our initial estimate, based on the extensive hydraulic modelling

performed, is that a water level of MSL + 5.2m with waves of 5.0m corresponds to a 1/100 yr<sup>-1</sup> situation. As additional efforts regarding the cost-benefit analysis will be required for the mid-term aims of the game plan, we will briefly explore and show the effects of higher protection levels (e.g. 1/1,000 year and 1/10,000 year) and/or resilience on the design of the land barrier. The difference in the resulting costs will be will also be discussed briefly in this phase.

### **Storm Surge Barrier**

The design of the Storm Surge Barriers in Bolivar Roads and San Luis Pass are treated in chapter 3, the hydraulic boundary conditions used for these designs are discussed in this section. Previous studies by the Delft University of Technology (Jonkman et al., 2013b) have assumed a 1/10,000 year protection level for the Storm Surge Barrier in Bolivar Roads. This protection level was based on a preliminary cost benefit analysis performed by Stoeten (Stoeten, 2013).

The storm surge barriers will be built for a design service life of 200 years, corresponding with the design service life of other storm surge barriers (e.g. the Eastern Scheldt barrier in the Netherlands). A storm surge barrier is less adaptable than a land barrier, which is why a robust design is required able to deal with possible changes of the hydraulic boundary conditions. Considering the longer design lifetime, reduced adaptability and robustness required for the storm surge barriers a higher design protection level (e.g. 1/1,000 year or 1/10,000 year) than the land barriers seems a logical choice. The previous studies have assumed a 1/10,000 year protection level. This report will continue to build on the earlier studies of the storm surge barrier, assuming a design protection level of 1/10,000 years.

This protection level requires resistance of the storm surge barriers to storm conditions with a return period of once in ten thousand years. Our initial estimate, based on the extensive hydraulic modelling performed, is that a water level of MSL + 7m with waves of 6.3m corresponds to a 1/10,000 yr<sup>-1</sup> situation. Especially these extreme situations, however, have a large uncertainty which should be substantiated with more extensive hydraulic modelling. This protection level does agree with common protection levels of storm surge barriers built in the Netherlands.

The hydraulic boundary conditions for the storm surge barriers are important for the required strength of the structure, as it was determined in previous studies that the barrier will serve as a reduction barrier which only blocks the forerunner surge completely. Surge levels exceeding the retaining height of the barrier during the 1/10,000 year conditions are allowed as long as the barrier will not collapse.

### **Future work**

Pragmatic choices for initial design have been made here. In future work, further investigation and optimization of protection levels is highly recommended. This can be done based on the consideration of a so-called cost benefit analysis or economic optimization. In such an approach the additional costs of better protection vs. risk reduction benefits are considered and optimized.

### Hydraulic boundary conditions

Different protection levels were chosen for the land barrier (1/100 per year) and the storm surge barrier (1/10,000 per year), because of the design service life, the adaptability and robustness of the structures. This paragraph will summarize the hydraulic boundary conditions for both the extreme situation (during a hurricane) and the regular (daily) conditions.

#### Regular conditions (water levels and waves)

The hydraulic boundary conditions in regular, every day, conditions are presented in Table 8. These conditions are given for the end of service life.

Variable	Value	Source
<b>Low tide (MLLW) (de Vries, 2014)</b>	0.90 m [NAVD88+m]	(de Vries, 2014)
<b>Mean Sea Level (MSL) (de Vries, 2014)</b>	1.15 m [NAVD88+m]	(de Vries, 2014)
<b>High tide (MHHW) (de Vries, 2014)</b>	1.54 m [NAVD88+m]	(de Vries, 2014)
<b>Significant wave height (<math>H_s</math>) in the Gulf</b>	$H_s=0.5\text{m}$	(de Vries, 2014)
<b>Peak wave period (<math>T_p</math>) in the Gulf</b>	$T_p=4.0\text{s}$	(de Vries, 2014)
<b>Maximum flow velocity through Bolivar Roads due to restriction of the inlet [m/s] (Ruijs, 2011)</b>	Closure 0%: 1.0 m/s Closure 40%: 1.3 m/s Closure 60%: 1.6 m/s	(Ruijs, 2011)

**Table 8: Regular hydraulic boundary conditions ( $H_s$  = Significant wave height,  $T_p$  = Peak wave period)**

In this initial phase of the design, pragmatic choices for protection levels have been made as outlined below.

#### Extreme situation

The hydraulic boundary conditions for the extreme conditions, during a hurricane, are summarised in the table below. The conditions are given for the end of the design lifetime of each structure, with respect to the current Mean Sea Level (year 2015). The conditions for the land barriers and the storm surge barriers have a different return period (1/100 and 1/10,000  $\text{yr}^{-1}$  respectively) corresponding with the design assumptions made in paragraph 2.2.

	<b>Bolivar Peninsula (1/100 <math>\text{yr}^{-1}</math>)</b>	<b>Bolivar Roads (1/10,000 <math>\text{yr}^{-1}</math>)</b>	<b>Galveston Island (1/100 <math>\text{yr}^{-1}</math>)</b>	<b>San Luis Pass (1/10,000 <math>\text{yr}^{-1}</math>)</b>
<b>Maximum water level in Gulf [MSL+m]</b>	5.2m <sup>1)</sup>	7.0m <sup>3)</sup>	5.2m <sup>1)</sup>	7.0m <sup>3)</sup>
<b>Minimum water level in Galveston bay [MSL+m]</b>	Not required for design	-1.0m <sup>3)</sup>	Not required for design	0.0m <sup>2)</sup>
<b>Positive head [m]</b>	Not required for design	8.0m <sup>3)</sup>	Not required for design	7.0m <sup>3)</sup>
<b>Maximum forerunner surge [MSL+m]</b>	3.0m <sup>1,6)</sup>	4.2m <sup>3,6)</sup>	3.0m <sup>1,6)</sup>	4.2m <sup>3,6)</sup>
<b>Waves on Gulf side</b>	$H_s=5.0\text{m}$ $T_p=7.2\text{s}$ <sup>4)</sup>	$H_s=6.3\text{m}$ $T_p=8.2\text{s}$ <sup>4)</sup>	$H_s=5.0\text{m}$ $T_p=7.2\text{s}$ <sup>4)</sup>	$H_s=6.3\text{m}$ $T_p=8.2\text{s}$ <sup>4)</sup>
<b>Waves on Bay side</b>	$H_s=2\text{m}$ $T_p=5\text{s}$ <sup>5)</sup>	$H_s=3\text{m}$ $T_p=6\text{s}$ <sup>5)</sup>	$H_s=1\text{m}$ $T_p=4\text{s}$ <sup>2)5)</sup>	$H_s=1\text{m}$ $T_p=4\text{s}$ <sup>2)5)</sup>

**Table 9: Hydraulic boundary conditions for the year 2115 (includes 100 year SLR)**

- 1) The 1/100 surge levels are estimated based on expert judgment, d.d. 21-4-2015, and previous modelling results (Rippi, 2014).
- 2) These conditions are based expert judgment. The set-up, set-down and wave height are limited by the size of the West Bay. Lower values than those of the Galveston Bay are therefore assumed.
- 3) The 1/10.000 year conditions are based on a technical note (Lendering et al. (2014)). The water levels as determined in the Barge Barrier Design phase 3 are based on a simplified model by Stoeten (2013). This model couples meteorological forcing with hydrodynamic response and provides a first-estimate of storm surge within simplified semi-enclosed bays. A large suite of synthetic parametric hurricane wind fields provides input for the storm surge model. Assessing the hydraulic boundary conditions in time for different hurricane landfall locations gives the critical boundary conditions as presented.
- 4) Wave heights are based on Jin et al (2012), Tables 8 and 12. These are derived for off shore waves, about 2 kilometres off coast. For the design of the land barrier near shore wave conditions are required, which will be derived in chapter 5.
- 5) The wave conditions inside the bay are assumed based on expert judgment, d.d. 15-4-2015. The waves in the Galveston Bay are assumed higher than in the West Bay due to larger fetch lengths. The peak period was determined based on a wave steepness of 0.05-0.06.
- 6) The estimates for the fore runner surge height are based on results of previous studies (Lendering et al, 2014). After including sea level rise and re-evaluation of these studies a fore runner surge of 4.2m+ MSL is assumed for the 1/10,000 year protection level and a fore runner surge of 3.0m+ MSL for the 1/100 year protection level. These are considered conservative assumptions, further modelling is recommended to determine more accurate estimates of the fore runner surge levels. For comparison purposes, Sebastian et al (2014) studied the surge levels from Ike and concluded that the fore runner surge for a category 5 storm which makes landfall at San Luis Pass would result in a fore runner surge just under 3 meter.

### **Reflection on boundary conditions**

The hydraulic boundary conditions were compared to results of FEMA analysis (FEMA, 2012). Based on the comparison, it is concluded that the hydraulic boundary conditions in this paragraph are consistent with those derived in this paragraph. There are some minor differences, which result from the uncertainties of the studies at this phase. The FEMA numbers do not vary significantly along the Texas coast, which is also consistent to the hydraulic boundary conditions derived in this paragraph. Many estimates associated with expected hydraulic boundary conditions will be better informed after ADCIRC modelling and related work is completed. Data of Jackson State have been received, which will be used in further investigation of hydraulic boundary conditions.

## B: Scour protection design

This appendix presents the results of the design of the scour protection. The scour protection is based on hydraulic loads caused by a hurricane as well as hydraulic loads caused by regular tidal flow.

### Governing condition barge gate

Loads on a scour protection can be caused by several conditions. Propeller jets of vessels and return current of navigation could have effect on the scour protection. These conditions are assumed to be not significant in relation to the extreme hydraulic loads in hurricane conditions. Regular tidal currents are, next to hurricane conditions taken into account for the design.

During hurricane conditions the barge gate is closed. The gate is supported at both ends and the gate in-between 'floats' 1.0 meter (3.3 ft.) above the bottom of the channel. Because of the weight of the gate itself and the under pressure due to the large currents (in hurricane conditions), the center of the gate displaces vertically with 0.45 m (1.5 ft.) (Lendering et al., 2014). This situation is sketched in Figure 19. Governing for flow velocities is the location with the largest opening under the gate. This means that the two outer sides of the barge gate are governing with respect to the flow velocity.

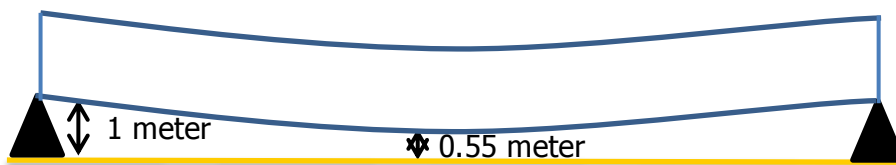

Figure 19: Sketch of front view of the barge gate with vertical displacement

Dynamic behaviour of the gate during governing conditions could have an effect on the opening underneath the gate and thus on the flow velocity. These effects are expected to be limited (Smulders, 2014). Dynamic behaviour in closed position is for this reason neglected in the bed protection design.

### Boundary conditions

#### Hydraulic boundary conditions

Governing hydraulic boundary conditions are presented in Figure 20 and Figure 21. Figure 20 displays the water levels for a maximum positive head of 8 m (26 ft.) if the hurricane has landfall 50 km west of Bolivar Roads. In Figure 21 the water levels for a landfall 250 km east of Bolivar Roads are shown. This causes a negative head of 3 m (10 ft.).

An even larger hydraulic head due to reflection of waves against the gate increases the flow velocity even more. Recommended is to investigate the effect of this phenomenon for the barge gate.

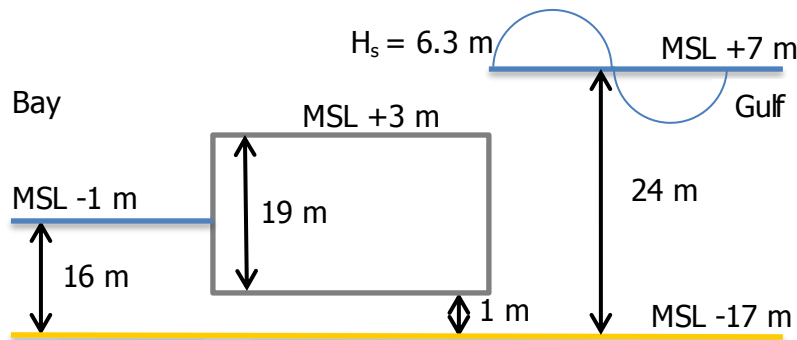

Figure 20: Side view of the barge gate with positive head of 8.0 m (26 ft.)

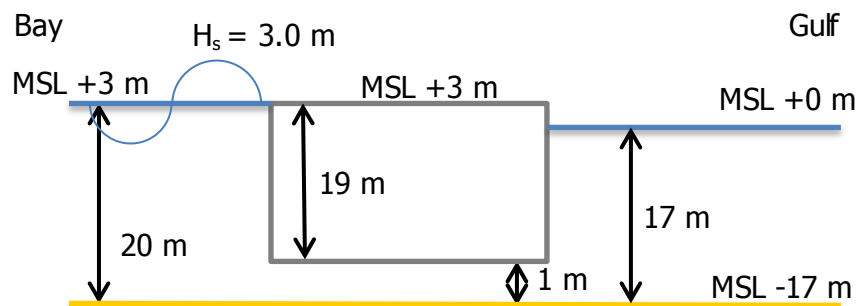
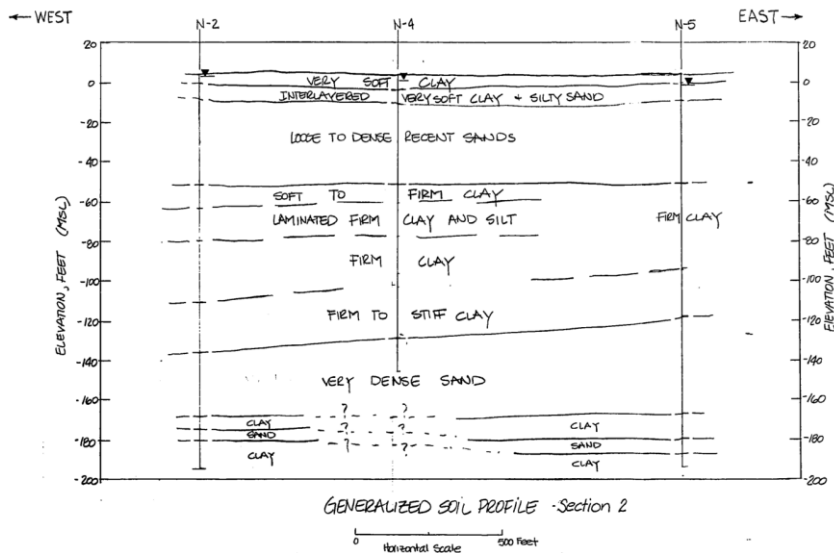

Figure 21: Side view of the barge gate with negative head of 3.0 m (10 ft.)

Two kinds of flow condition can be distinguished during a hurricane: overtopping due to waves & overflow and underflow. Also, regular tidal conditions have effect on the scour protection design. According to chapter 2, with 40% of the flow area blocked due to the Bolivar Roads barrier, the tidal flow has a maximum average flow velocity of 1.3 m/s. However, this velocity is only valid close to the barrier. At some distance from the barrier, the tidal flow is not blocked anymore and the tidal flow velocity can be assumed 1.0 m/s (averaged in width and depth).

#### Geotechnical boundary conditions

The geotechnical soil profile near the gate is displayed in Figure 22. An important assumption is made regarding the subsoil. At the bottom of the shipping channel MSL -17 m (= MSL-56 feet), a soft to firm clay layer is situated. However, just above this clay layer a thick sand layer is present. Since the borings are taken at the east end of Galveston Island, it is not sure if this soil profile is present at the location of the barrier. For this reason a conservative approach is made and the scour protection is designed for a sand bed. It is recommended to obtain a more detailed soil profile, including grain diameters and other soil characteristics, at the location of the scour protection. If the subsoil appears to be clay instead of sand, an optimization for the length of the scour protection is possible.



**Figure 22: Soil profile (McClelland Engineers, 1985)**

### Design steps

The bed protection is designed according to the design steps below:

1. Flow velocity vs. time
2. Flow velocity (underneath the gate and wash over) vs. distance behind gate
3.  $D_{n50}$  vs. distance behind gate
4. Critical failure length bed protection (indication length)
5. Scour hole at end of bed protection
6. Horizontal design bed protection
7. Bed protection under the barge gate
8. Vertical design bed protection

### Design of the bed protection

The aforementioned design steps are worked out below.

#### Flow velocity in time

Based on the figures with water levels in time during a hurricane from Lendering et al. (2014) and the boundary conditions, the hydraulic head and the corresponding flow velocity is sketched. Figure 23. displays the hydraulic head and flow velocity for a landfall 50 km west of Bolivar Roads. Figure 24 displays the hydraulic head and flow velocity for a landfall 250 km east of Bolivar Roads. As conservative indication the duration of governing conditions for both positive head can be established at 8 hours, for negative at 6 hours.



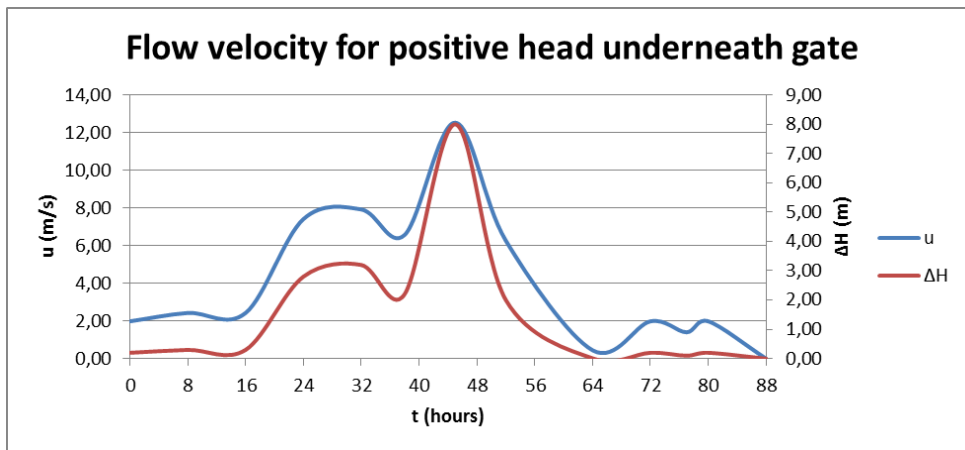

**Figure 23: Sketch of hydraulic head and flow velocities underneath the gate for a hurricane with landfall 50 km west of Bolivar Roads**

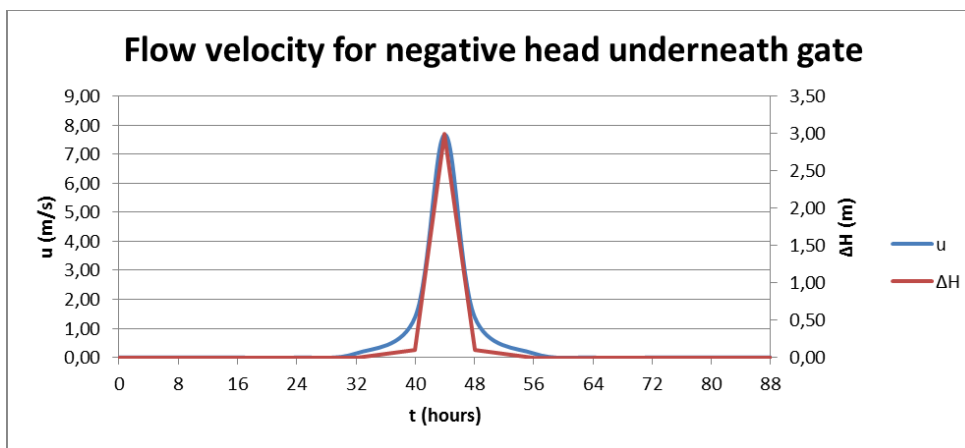

**Figure 24: Sketch of hydraulic head and flow velocities underneath the gate for a hurricane with landfall 250 east of Bolivar Roads**

### ***Flow velocity (under the gate and overflow) vs. distance behind gate***

#### **Underneath the gate**

The flow velocity is calculated with the law of Torricelli,  $u = \sqrt{2gh}$ . A contraction coefficient of 0.8 is used. There is assumed that the flow velocity diverges vertically with a slope of 1:12. For both calculations of positive hydraulic head and negative hydraulic head, the maximum hydraulic head is used. Energy losses due to inflow and outflow are not taken into account.

In Figure 25 the flow velocity for the positive head of 8 m (26 ft.) is displayed. Figure 26 displays the velocity in front of the gate for a negative hydraulic head of 3 m.

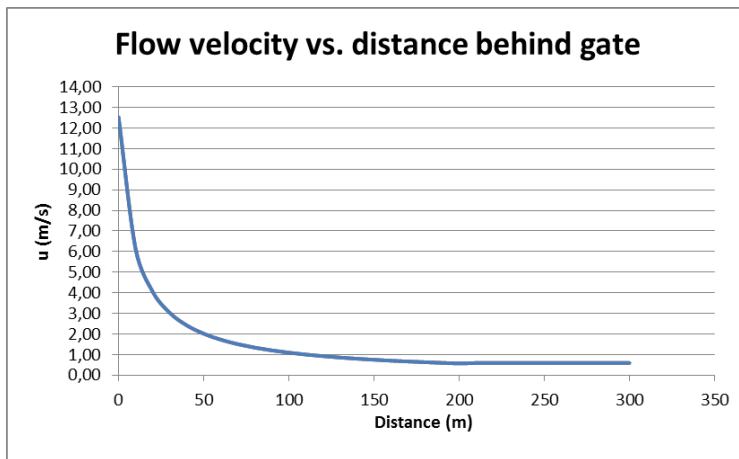

Figure 25: Flow velocity vs. distance behind gate (Bay side)

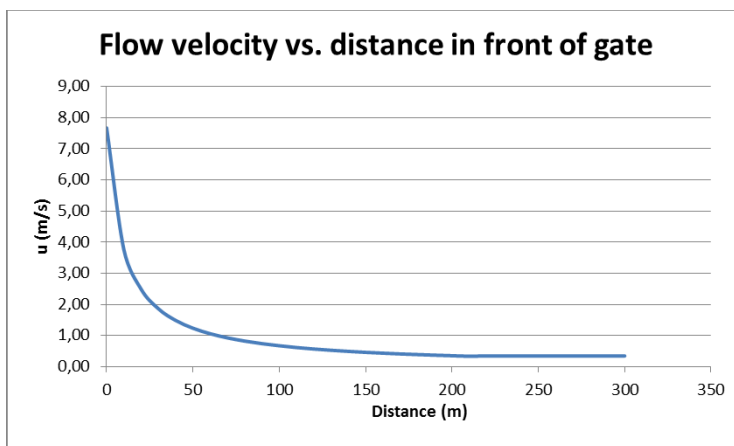

Figure 26: Flow velocity vs. distance in front of gate (Gulf side)

### Overflow and overtopping

The discharge over the gate consists of overflow and overtopping by waves. With the discharge over the gate the flow velocity at the water level can be calculated. There is assumed that the velocity spreads with slope 1:6 in the water body. The velocity at the bottom due to wash over is 2.6 m/s. The flow velocity caused by underflow is governing. The effect of the flow velocity in horizontal direction due to the wash over is calculated with the same vertical slope spreading (1:12) as the underflow.

### ***Dn50 vs. distance behind gate***

For the calculated flow velocities the corresponding nominal stone diameters are calculated. The required nominal stone diameters are calculated with Pilarczyk formula (CIRIA, 2007). Important parameters are  $\rho_s$ : 2650 kg/m<sup>3</sup>,  $r_0$ : 0.6 and Kt: 2.15.

Figure 27 displays the required nominal stone diameter behind the gate (for a positive head), Figure 28 displays the required nominal stone diameter in front of the gate (for a negative head). Close to the gate (33 meter (108 ft.) behind the gate and 16.5 meter (54 ft.) in front of the gate) loose rock is not a suitable solution. For this part with extreme flow velocities another solutions (e.g. concrete block elements) are needed. This is discussed in the paragraph 'Bottom protection under the barge gate' further on in this appendix.

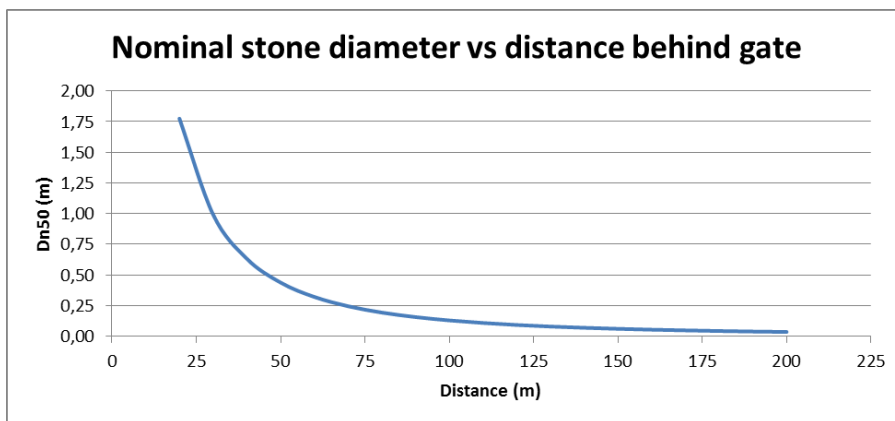

**Figure 27: Nominal stone diameter vs. distance behind gate (Bay side)**

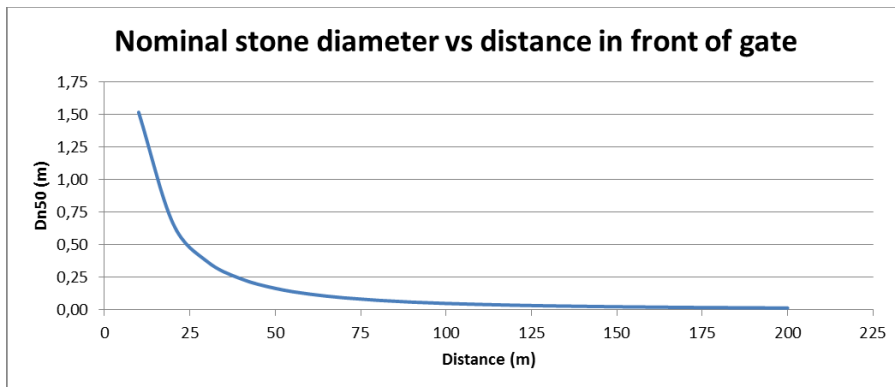

**Figure 28: Nominal stone diameter vs. distance in front of gate (Gulf side)**

### **Critical failure length (indication, time independent)**

As indication the minimum length of the bed protection is calculated with the formula based on the stability of the structure (Hoffmans & Verheij, 1997). The formula is time independent.

$$L_s = \frac{1}{2} \cdot y_m \cdot (\cot \gamma_2 - \cot \beta_a)$$

For tidal flow with 1 m/s and  $r_0 = 0.1$  the equilibrium depth of the scour hole ( $y_m$ ) is 35 m (115 ft.). With  $\gamma_2 = 6^\circ$  and  $\beta_a = 30^\circ$  a length of 140 m (460 ft.) bed protection behind and in front of the gate is calculated.

A scour hole of 35 meter (115 ft.) is quite common for such hydraulic structures and is not a problem if the scour hole is at a proper distance. The depth of the scour hole is dependent on local soil features.

The hydraulic load of a hurricane is relatively short but heavy and the hydraulic load of the tidal flow low, but assumed as eternal. The fact that the tidal movement is assumed eternal makes it governing for the length of the scour protection.

These values are valid for sand. For a clayey subsoil probably a shorter length would be calculated. However, the formula is only applicable for sandy subsoil.

The critical velocity for low/medium density clay is about 1.0 m/s (Hoffmans & Verheij, 1997). For sand this velocity is about 0.4 m/s. The scour holes and length of the bottom protection will be smaller for clay than for sand. It is recommended to investigate these aspects for a clayey subsoil if a more detailed subsoil profile is available.

### **Scour hole at end bed protection due to hurricane (time dependent)**

The scour hole is calculated with the time dependent Dutch scour formula (Hoffmans & Verheij, 1997). For a time of 8 hours and a flow velocity of 0.8 m /s (velocity at 140 m, 460 ft.) a scour hole behind the gate will develop as in Figure 29. Based on sandy bottom profile. The grain size is unknown. The grain size is estimated at 0.5 mm (0.02 inch). The grain sizes 0.1 mm and 1 mm are plotted too. The tidal conditions are governing.

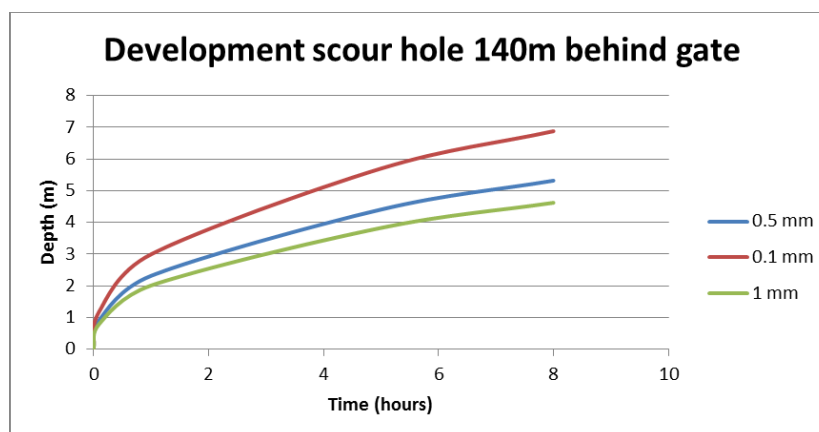

**Figure 29: Development of scour hole behind the gate (Bay side)**

For a time of 6 hours, and a flow velocity of 0,49 m/s (velocity at 140 m) a scour hole in front of the gate will develop as in Figure 30. The tidal conditions are governing.

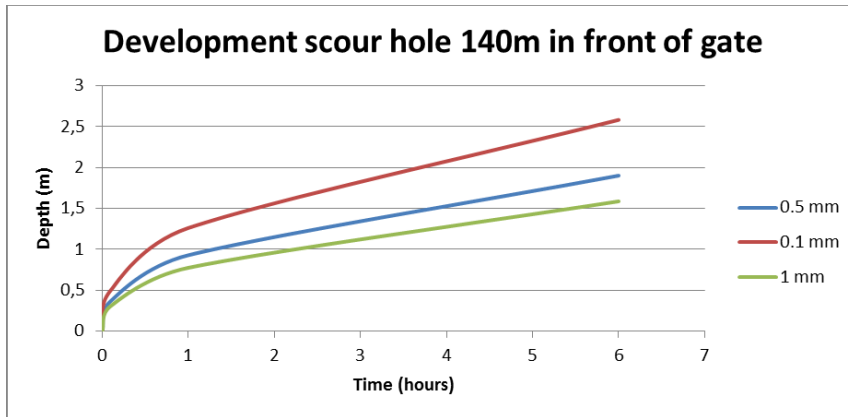

Figure 30: Development of scour hole in front of gate (Gulf side)

The depths of the scour holes for tidal flow as calculated in 'Critical failure length (indication)' are governing. The length of the bottom protection is determined by tidal flow.

**Horizontal design bed protection**

The horizontal design of the bed protection is made with standard classes of rock grading. In the plot of the calculated  $D_{n50}$ , the standard rock classes are marked (Standard classes of rock grading from EN 13383 are used).

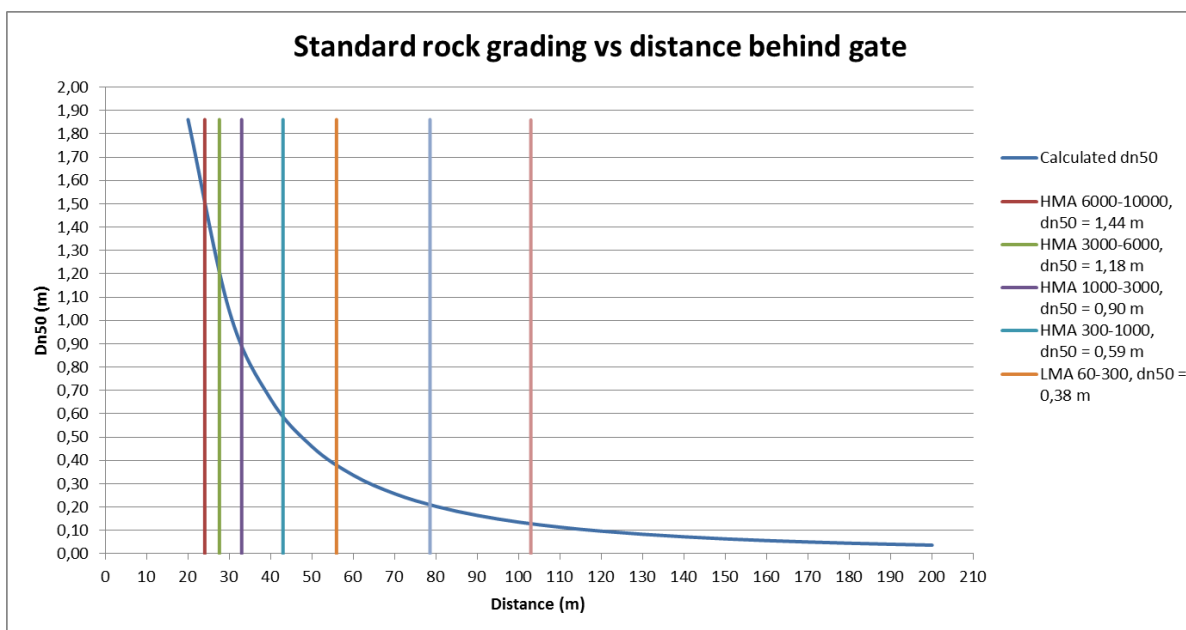

Figure 31: Standard rock classes with calculated  $D_{n50}$  behind gate (Bay side)

Because of the small distance between the largest  $D_{n50}$  it is advised to enlarge the solution under the barge gate (e.g. concrete block elements) to 33 m (108 ft.). With this expansion, the first two base rock layers are not necessary. The bottom protection is designed with a length of 140 m due to tidal flow.

The horizontal design of the bed protection behind the gate (Bay side) is displayed below.

0 m till	33.0 m	Specific design (e.g. concrete elements)
33.0 m till	43.0 m	HMA 1000-3000, $dn_{50} = 0,90$ m
43.0 m till	55.9 m	HMA 300-1000, $dn_{50} = 0,59$ m
55.9 m till	78.5 m	LMA 60-300, $dn_{50} = 0,38$ m
78.5 m till	102.9 m	LMA 10-60, $dn_{50} = 0,21$ m
102.9 m till	140.0 m	CP 90/250, $dn_{50} = 0,128$ m

In front of the gate (Gulf side) the horizontal bed protection is designed below (Standard classes of rock grading from EN 13383 are used).

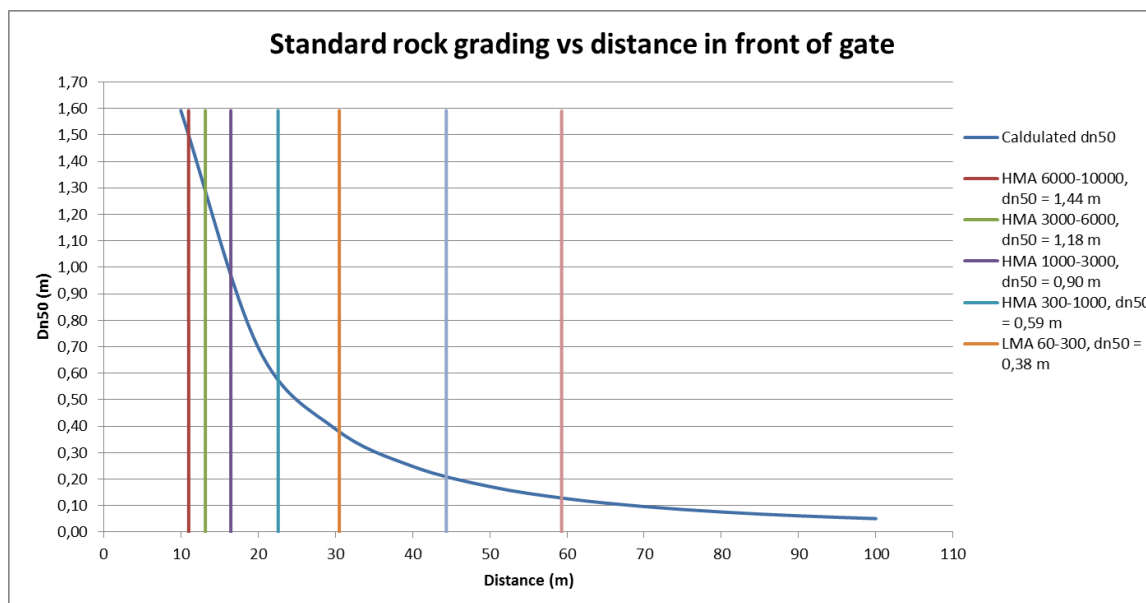

**Figure 32: Standard rock classes with calculated  $D_{n50}$  in front of the gate (Gulf side)**

Because of the small distance between the largest  $D_{n50}$  it is advised to enlarge the solution under the barge gate (e.g. concrete block elements) to 16.5 m (54 ft.). With this expansion, the first two base rock layers are not necessary. The bottom protection is designed with a length of 140 m due to tidal flow.

The horizontal design of the bed protection in front of the gate (Gulf side) is displayed below.

0 m till	16.5 m	Specific design (e.g. concrete elements)
16.5 m till	22.6 m	HMA 1000-3000, dn50 = 0,90 m
22.6 m till	30.5 m	HMA 300-1000, dn50 = 0,59 m
30.5 m till	44.4 m	LMA 60-300, dn50 = 0,38 m
44.4 m till	59.3 m	LMA 10-60, dn50 = 0,21 m
59.3 m till	140.0 m	CP 90/250, dn50 = 0,128 m

The scour protection as designed below protects against the hurricane conditions as well as the tidal conditions. At the bay side the first 80 meter (260 ft.) is needed for the protection in hurricane conditions. The scour protection from 80 meter up to 140 meter (460 ft.) from the barrier at the bay side serves the purpose to protect against the erosive power of regular tidal flow. At the Gulf side the first 40 meter (130 ft.) is needed to protect against hydraulic loads due to hurricanes. From 40 meter up to 140 meter the scour protection serves the purpose to protect against the erosive power of regular tidal flow.

Summarizing: hydraulic loads due to regular tidal conditions are governing for the length of the scour protection. Hydraulic loads due to hurricane conditions are governing for the first 80 meter (260 ft.) at the bay side and for the first 40 meter (130 ft.) at the Gulf side.

#### **Bottom protection under gate**

Directly under the barge gate and in the front and the back of the barge gate loose rock as bottom protection is not stable. Therefore more stable solutions are evaluated, for example:

- Rock penetrated with concrete or asphalt;
- Mattress with concrete blocks;
- Box gabions or gabion mattress;
- Sack gabions;
- Concrete block elements.

A disadvantage of penetrated rock is that a high penetration volume is required to ensure the stability of the individual rocks. Since penetration of rock is normally applied by standard rock grading of not larger than LMA 10-60 it is not sure if the total layer thickness can be penetrated under flow conditions. This solution also requires a longer construction time due to large area which needs to be protected.

Mattresses with concrete blocks will require relatively large block dimensions and therefore it seems no suitable solution to prefabricate the blocks on mattresses. Another large disadvantage of block mattresses is the edges, which are extremely vulnerable for lifting and therefore failure of the entire mattress. Therefore the execution needs to be very careful to prevent exposed edges.

Another possible solution for the high flow velocities are the gabion mattress. Gabions are wired boxes filled with rock. To prevent erosion of the base material under the gabion



mattress an additional layer of loose rock on a fascine mattress is required. A disadvantage is that if a gabion is damaged, it is not easily replaced due to its fixed shape.

Sack gabions are gabions with a flexible wire net. An advantage is that they are easily replaced if one is washed away. These sack gabions are used in Korea for the Saemangeun dam. They were however filled with small rocks and probably not heavy enough for the considered loads. Therefore large maintenance works may be required after a hurricane.

The most suitable solution for the high flow velocities seem concrete elements. The dimensions of the concrete elements need to be elaborated more into detail. The dimensions of concrete elements vary. Typical ranges for this purpose are 5 x 5 x 2 m (Maeslant barrier). Advantage of concrete block elements is that they are durable, can be prefabricated and cover relatively large areas at once.

Since concrete elements are already needed for the part directly under the gate, the design consideration to make the barge non-floating in closed position is strengthened. These concrete elements can be used as sill for the gate to rest on. Also settlement differences are no problem.

The main issue is that the flow depth directly under the gate is very small. A jet occurs with a maximum flow height of 1 m. Since the elements are larger than the flow height practical formula cannot be applied.

#### **Vertical design bed protection**

The vertical design of the bed protection is based on the geometrically closed filter rules. Since standard rock classes are used, there is assumed that the internal stability is guaranteed. The vertical design for the bed protection behind the gate is displayed below. Since the large water depth and the yet undefined construction method, a minimum layer depth of 2 times dn50 is assumed.

**Table 10 – Vertical design bed protection behind the gate (Bay side)**

<b>Distance</b>	<b>33 m till 43 m</b>	<b>43 m till 55.9 m</b>	<b>55.9 m till 78.5 m</b>
<b>Top layer (Thickness, minimum dumping quantity)</b>	HMA 1000-3000, dn50 = 0.90 m (1.8 m, 2862 kg/m <sup>2</sup> )	HMA 300-1000, dn50 = 0.59 m (1.18 m, 1876 kg/m <sup>2</sup> )	LMA 60-300, dn50 = 0,38 m (0.76 m, 1208 kg/m <sup>2</sup> )
<b>Layer 2 (Thickness, minimum dumping quantity)</b>	LMA 5-40, dn50 = 0,17 m (0.34 m, 541 kg/m <sup>2</sup> )	CP 90/250, dn50 = 0,128 m (0.26 m, 414 kg/m <sup>2</sup> )	CP 45/180, dn50 = 0,064 m (0.13 m, 207 kg/m <sup>2</sup> )
<b>Layer 3</b>	Fascine mattress	Fascine mattress	Fascine mattress

<b>Distance</b>	<b>78.5 m till 102.9 m</b>	<b>102.9 m till 140 m</b>
<b>Top layer (Thickness, minimum dumping quantity)</b>	LMA 10-60, dn50 = 0.21 m (0.42 m, 668 kg/m <sup>2</sup> )	CP90/250 dn50 = 0.128 m (0.26 m, 414 kg/m <sup>2</sup> )
<b>Layer 2</b>	Fascine mattress	Fascine mattress

**Table 11 – Vertical design bed protection in front of the gate (Gulf side)**

Distance	16.5 m till 22.6 m	22.6 m till 30.5 m	30.5 m till 44.4 m
<b>Top layer (Thickness, minimum dumping quantity)</b>	HMA 1000-3000, dn50 = 0.90 m (1.8 m, 2862 kg/m <sup>2</sup> )	HMA 300-1000, dn50 = 0.59 m (1.18 m, 1876 kg/m <sup>2</sup> )	LMA 60-300, dn50 = 0,38 m (0.76 m, 1208 kg/m <sup>2</sup> )
<b>Layer 2 (Thickness, minimum dumping quantity)</b>	LMA 5-40, dn50 = 0,17 m (0.34 m, 541 kg/m <sup>2</sup> )	CP 90/250, dn50 = 0,128 m (0.26 m, 414 kg/m <sup>2</sup> )	CP 45/180, dn50 = 0,064 m (0.13 m, 207 kg/m <sup>2</sup> )
<b>Layer 3</b>	Fascine mattress	Fascine mattress	Fascine mattress

Distance	44.4 m till 59.3 m	59.3 m till 140 m
<b>Top layer (Thickness, minimum dumping quantity)</b>	LMA 10-60, dn50 = 0.21 m (0.42 m, 668 kg/m <sup>2</sup> )	CP90/250 dn50 = 0.128 m (0.26 m, 414 kg/m <sup>2</sup> )
<b>Layer 2</b>	Fascine mattress	Fascine mattress

In Figure 33, a schematic cross section of the bed protection is displayed.

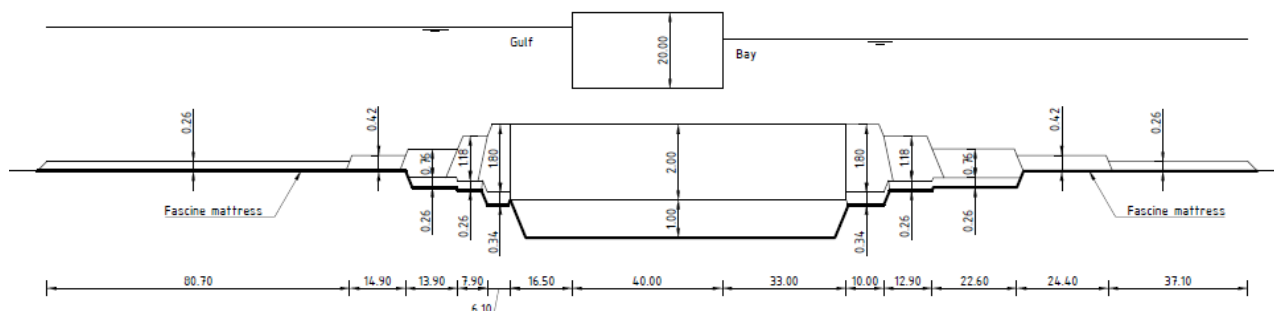
**Figure 33: Sketch of the cross section of the bed protection**

### **Bed protection near Dutch Storm Surge Barriers**

The Dutch Eastern Scheldt storm surge barrier has a scour protection length of about 600 m (2,000 ft.). The length of the Bolivar Roads storm surge barrier is shorter. The main reason for the difference in length is that the scour protection of the Eastern Scheldt storm surge barrier is designed including failure of one single gate (of the total 66 gates). If this single gate fails, a jet with the height of the water depth enters the bay. This jet is unable to spread over the depth, since the jet occupies almost the complete water column. This causes a large erosive force and thus a longer scour protection.

The Maeslant barrier is designed with concrete block elements of 5 x 5 x 2 m as sill. The length of the scour protection is in the order of magnitude of a few hundred meters.

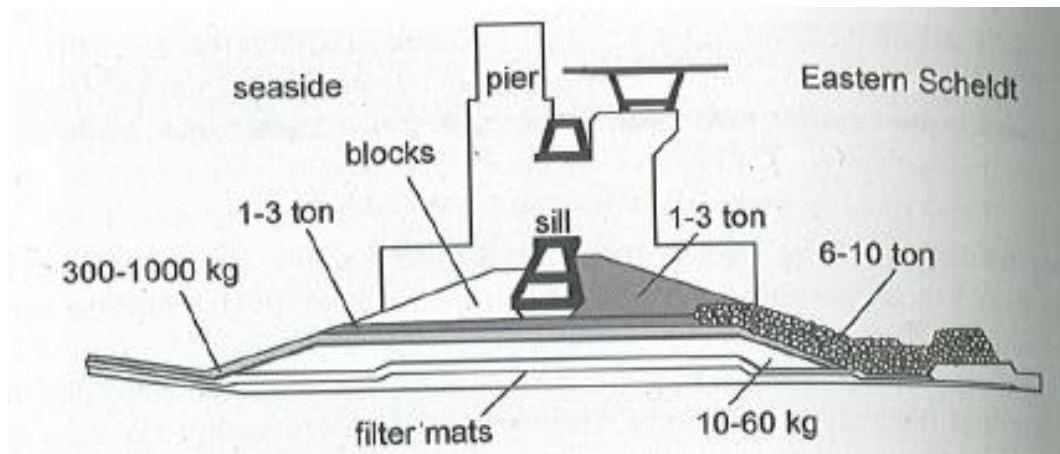

Figure 34: Sketch of the Eastern Scheldt scour protection (Schierck & Verhagen 2012)

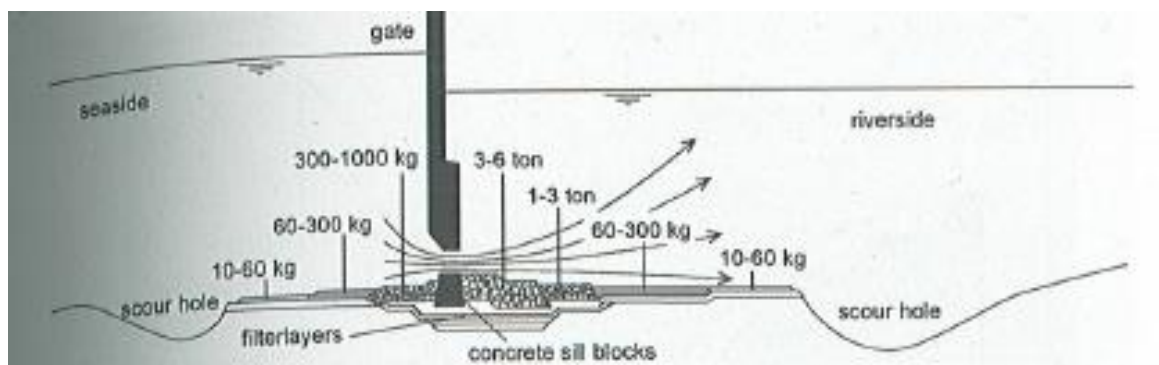

Figure 35: Sketch of the Maeslant barrier scour protection (Schierck & Verhagen 2012)

## C: Environmental section

This section presents three feasible designs for the environmental section:

- 1) Shallow foundation: This variant is based on the Eastern Scheldt barrier. Here, a very thick soft layer is present similar to the situation at the Bolivar Roads. The concept is that a very wide foundation is applied, spreading the loads caused by the head over the structure. Preventing very deep foundations allow easier manufacturing and, therefore, reduce costs.
- 2) Pile foundation: This variant is based on the design of the IHNC barrier. Here, piles were driven into the ground to achieve significant resistance against hydraulic loads.
- 3) Flip gates: An innovative idea to prevent visibility during normal conditions, but remain structural simplicity. Similar to solution 2 a pile foundation is applied.

In the next sections first a basis of design is shown, valid for all three solutions. Then the three designs are presented. Their structural principle is described and their main elements and dimensions are indicated. Furthermore, two recommendations for further study are provided for every variant. Chapter 6 describes the costs that are associated with this part of the storm surge barrier.

### Basis of design

This section describes the boundary conditions (BC), requirements (R) and basic design assumptions (BDA). They are listed below:

- BC: A soft clay layer is present between MSL-10m and MSL-40m. A strong bearing sand layer starts below MSL-40m.
- BC: The barrier will be designed for  $1/10,000 \text{ yr}^{-1}$  conditions. This corresponds to a forerunner surge height of MSL+4.2m, a peak surge height of MSL+7.0m and a significant wave height of 6.3m.
- BC: The maximum negative head over the barrier is 3.0m.
- R: The design service life of the environmental barrier is 100 years, which is considered normal for hydraulic structures in the Netherlands and the USA.
- R: The barrier should block the forerunner surge only, but should be able to bear forces due to overflow. Generally, they should remain stable during hurricane conditions.
- BDA: The environmental barrier will consist of multiple gates to reduce the span. The span of the gates is assumed to be 50 m (160 ft.). This is based on a normal ratio between gate span and the average local depth (10m, 33 ft.). In this way, a relatively large opening is achieved, approximately 70% of the original opening. The tide is then only limitedly constricted ( $\sim 5\%$  reduction in tidal range). Larger openings are possible at all variants, but will require additional costs. Openings larger than 100% of the original opening can cause sedimentation problems and are, therefore, not recommended. For now, an opening 70% of the original opening is chosen. In a later stage, the required water quality in the Galveston Bay should be further studied to find the appropriate size of the opening.

- BDA: The depth of Bolivar Roads deviates along the span of the environmental barrier. In this quick scan a representative depth of 10m is assumed. This is the most common depth along the barrier span. A limited amount of sections are deeper (15 to 17m), for this section the retaining height of the barrier is increased locally.
- BDA: The environmental barrier has a span of 2400 meter (7,900 feet), which is found when the total width of the navigational section (including abutments about 350 meter, 1100 ft.) is subtracted from the total width of Bolivar Roads ( $\pm 2750\text{m}$ ).
- BDA: The environmental barrier has a span of 2400 meter, which is found when the total width of the navigational section (including abutments about 350 meters) is subtracted from the total width of Bolivar Roads ( $\pm 2750\text{m}$ ).
- BDA: as the storm surge barrier will be placed on a cohesive (clay) subsoil with low permeability no seepage erosion measures are designed.
- BDA: A similar scour protection is applied at the environmental section as the navigation section. Because the hydraulic boundary conditions are expected to be less severe, the scour protection is assumed to be stable.
- BDA: For recreational traffic an additional lock is proposed. This, however, will only have a small contribution to the total costs. Therefore, it is not designed further in this stage.

Generally, the solutions are presented on a sketch design level, meaning that they are based on engineering experience with some indicative calculations.

### **Solution 1: Shallow Foundation**

The principle of this barrier is based on the Eastern Scheldt barrier. The barrier shall be a shallow founded construction with vertical lifting gates. It shall be constructed as light as possible, to limit the (unequal) settlements of the weak clay subsoil.

One of the key elements of this barrier is its *three* vertical lifting gates instead of the usual single gate. In opened situation the barriers have to be hoisted above the water level. By using three vertical lifting gates instead of one the total height of the lifting towers can thereby be decreased (see Figure 8). This is preferred to limit visibility and to a lesser extent decrease vertical loads, as the vertical lifting gates transfer the loads to the towers that are connected to a continuous footplate.

Initial calculations into the stability of the entire structure in storm conditions show that the footplate needs to be very wide to counteract overturning moment and spread vertical pressure over the subsoil. A plate of 60 meter (200 ft.) wide and 3 meter (10 ft.) thickness is required. The depth of the structure can decrease the settlement as the founding layer is already preloaded by the earlier soil on top of this layer.

The weight of this structure can be debated. A light structure reduces settlements, but also horizontal resistance. A way to do so is applying light-weight footplate which is partially filled with foam that makes the construction very light. A light structure should be combined with skirts at each end of the footplate. Through constructing skirts on either side of the caissons, the horizontal resistance of the caissons can be increased. Caisson skirts will penetrate into the ground and provide additional resistance against horizontal forces using passive soil pressure.

Taking the abovementioned aspects into account more research into the trade-off between settlements and horizontal friction capacity is required to determine the feasibility of this solution.

Alternative 1: Shallow Foundation with Vertical Lifting Gates

Closed situation

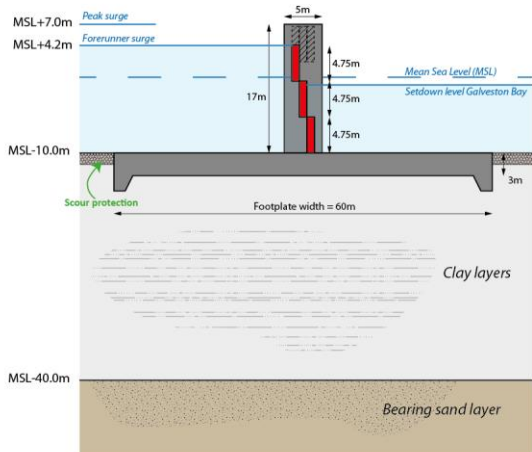

Opened situation

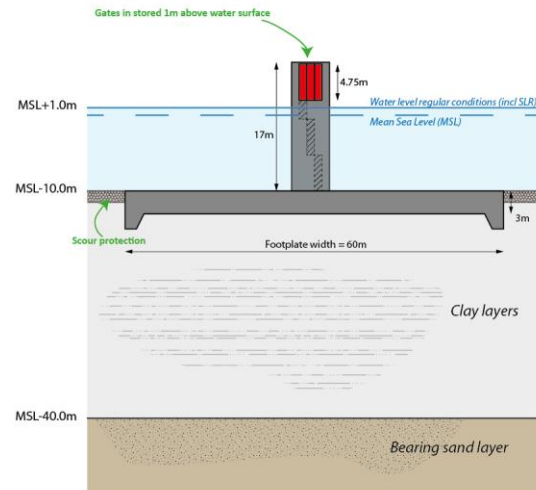

**Figure 36: Cross section sketch design solution 1 in closed (water retaining) and opened situation**

Top view

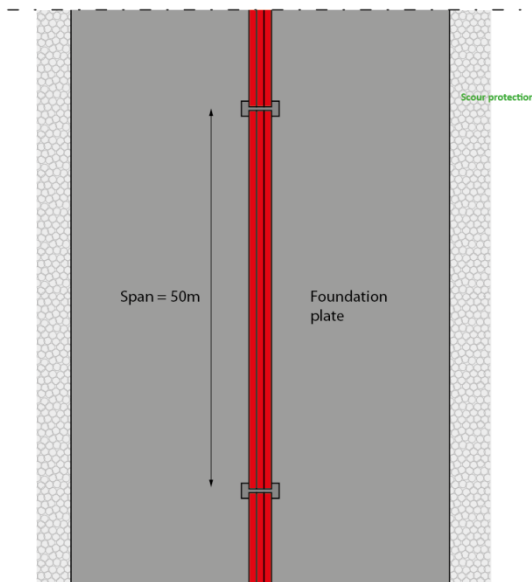

**Figure 37: Top view sketch design of solution 1**

### **Further research**

Suggestions for further research are listed below.

- Taking the before mentioned discussion into account more research into the trade-off between settlements and horizontal friction capacity is required to determine the feasibility of this solution.
- Due to the stability of a single retaining barrier as presented above the footplate has to be very wide to bear the horizontal loads (and to a lesser extent also the overturning moment). An option could be to spread the water head over 2 towers, on two different footplates, making a 'tiered' or 'stepped' flood defense. This helps in decreasing the adverse horizontal loads on the construction. Other options such as deep soil mixing, replacement of weak clay layers can be considered as well.

### **Solution 2: Pile foundation**

Contrary to the shallow founded barrier, the starting point of this alternative is that a pile foundation is applied. The barrier transfers all of the horizontal and vertical loads to the bearing sand layer at MSL-40m layer through steel tubular piles. Steel tubular piles have proven to be an excellent way in bearing heavy loads to large depths. Furthermore, this technique was applied in the U.S.; the IHNC Lake Borgne Surge Barrier in New Orleans.

Vertical radial gates are suspended on towers as indicated in Figure 38. The radial gates transfer the loads via the guide rail and hinge towards the pile foundation. This pile foundation bypasses the weak clay layers and transfers all the loads to the bearing sand layer. Large (unequal) settlement of the construction is thereby prevented. It is suggested to construct the steel tubes closed-ended and fill them with concrete. This makes them less vulnerable for corrosion on the inside.

Radial gates are widely experienced movable gates. They were, for example, already used in the Haringvliet barrier in the Netherlands. In opened situation, the entire radial gate is positioned above the water surface (including the hinge), making it easily accessible for inspection and maintenance.

As the superstructure that supports the radial gates can be constructed fairly small, a relatively large effective flow area will be available for water exchange between the Gulf of Mexico and the Galveston Bay. Based on earlier studies, per tower 4 foundation piles of approximately 32 m (105 ft.) length and 2m (6.6 ft.) diameter will be required.



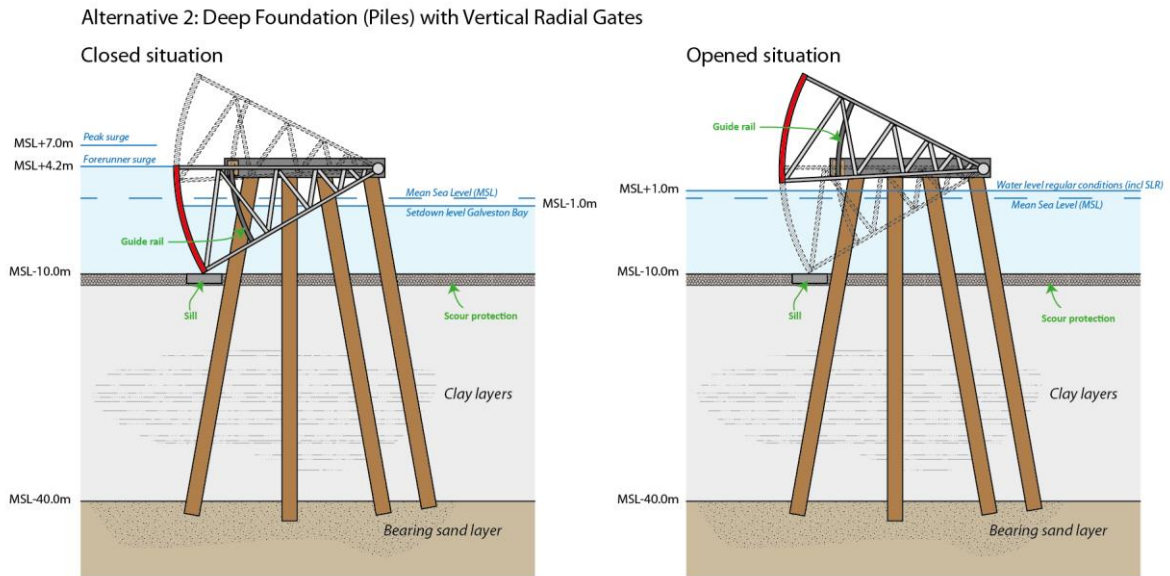

**Figure 38: Cross section sketch design solution 2 in closed (water retaining) and opened situation**

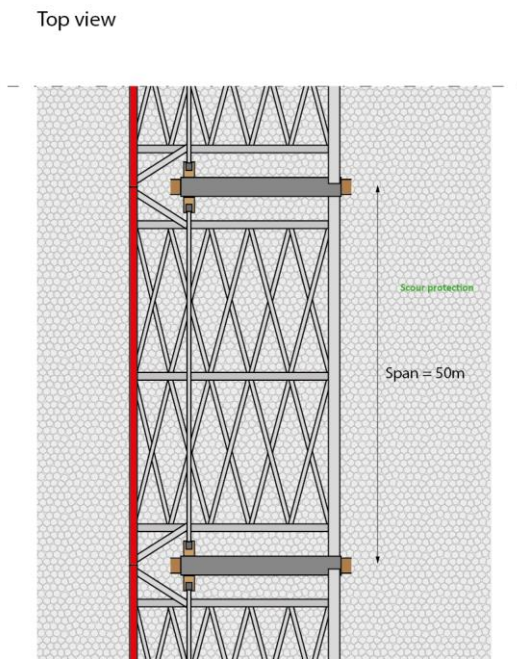

**Figure 39: Top view sketch design of solution 2**

### **Further research**

Suggestions for further research are listed below.

- A bridge that connects all of the towers is an interesting option to increase accessibility both during execution of the project and operation. However, this is not included in this design.
- In Figure 4 the barrier is presented for the case when a positive head due to hurricane surge occurs. In this load case radial gates are able to effectively bear the horizontal load. The loads due to this negative head could be easily relieved by constructing valves in the gates. This, however, should be studied further.

### **Solution 3: Flip gates**

The two alternatives presented before both protrude above the water surface in regular conditions. Local communities in Texas would better support a solution with less visual disturbance. The third solution's main aim is to prevent visibility, but remain structural simplicity. The entire structure, including the moveable gates, is during regular conditions under the ebb-tide level. Similar to solution 2 a pile foundation is applied.

In fact, it is a moveable retaining plate that is suspended on two steel tubular foundation piles. Similar to solution 2, the foundation piles avoid the weak clay layers and the loads are directly transferred down to the bearing sand layer.

In regular conditions, the flip gate is placed in horizontal position to enable water exchange between the Galveston Bay and the Gulf of Mexico. When a high water level is expected, the flaps will be rotated around the hinge into a vertical position. The higher water pressure on the Gulf of Mexico side presses the flip gate against the sill and keeps it in this position. When the water heads flips from positive to negative, the flip gate is opened under the pressure of this negative head.

Similar to solution 2, the superstructure that supports the flip gates can be constructed fairly slender. A relatively large effective flow area will be available for water exchange between the Gulf of Mexico and the Galveston Bay.

Alternative 3: Deep Foundation (Piles) with Invisible Flap Gates

Closed situation

Opened (invisible) situation

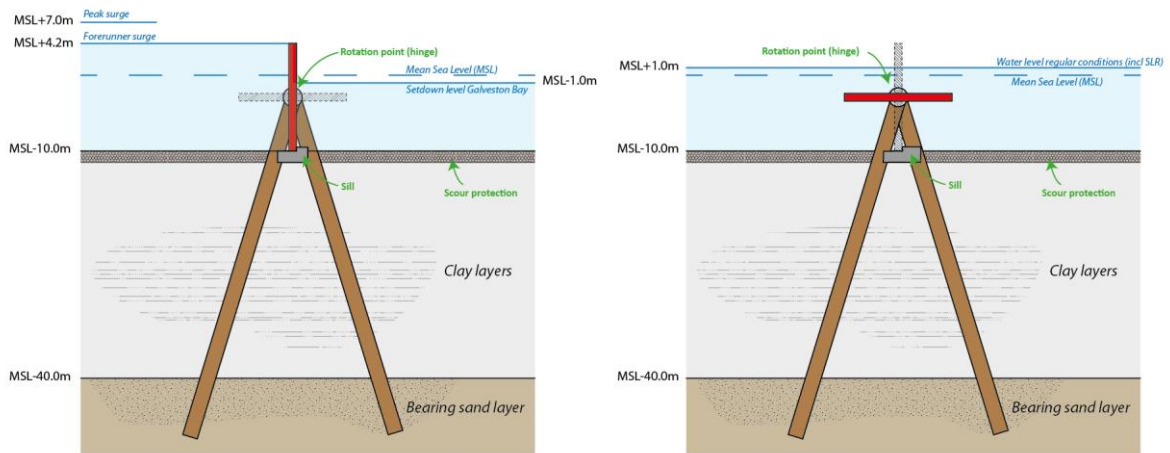

**Figure 40: Cross section sketch design solution 3 in closed (water retaining) and opened situation**

Top view

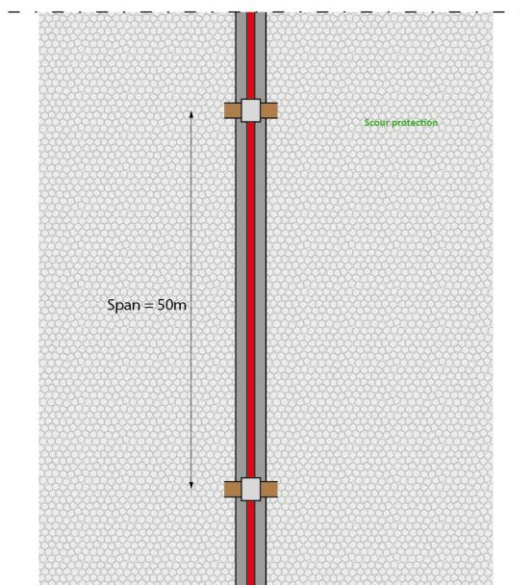

**Figure 41: Top view sketch design of solution 3**

***Further research***

The invisible flip gate is an innovative concept that requires more research before it can be considered as a feasible option for the environmental barrier.

- The load transfer occurs via the hinge and sill down to the foundation. This sill and hinge face many challenges. The way the sill and hinge transfer these loads is yet unclear.
- The exact closure/opening procedure of the flip gate with respect to the water heads needs to be thoroughly examined. Also its vulnerability to waves and turbulent water overflow are design challenges that have to be accounted for.

## D: San Luis Pass

The San Luis Pass is situated at the southern end of the Bay, as indicated in Figure 42.



**Figure 42: Top view of San Luis Pass**

The San Luis Pass has a length of approximately one kilometer (3,300 ft. see Figure 43) and has an opening of 2000-3000 m<sup>2</sup> (22,000-33,000 ft<sup>2</sup>. 10-15% of Bolivar Roads). Surge contribution/inflow will not be very significant if you consider the current cross section. However, the flow velocities through this opening will be very high (because of the larger head difference if you close Bolivar Roads) and enormous scour can be expected if you leave this gap open during a hurricane.

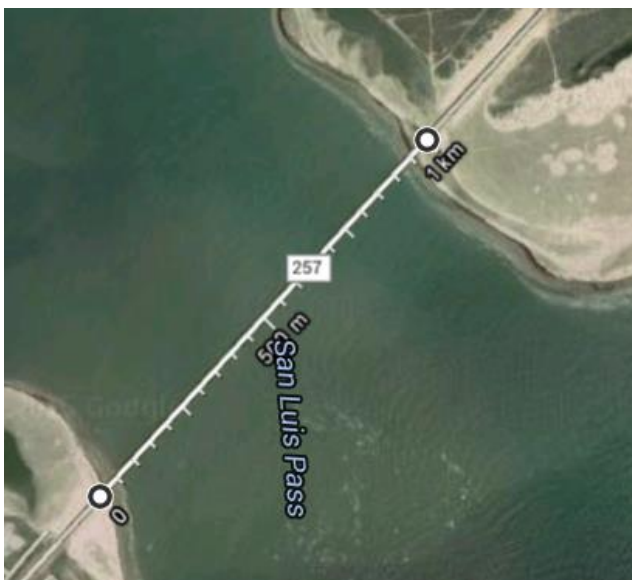

**Figure 43: Length of the San Luis Pass**

Like the Bolivar Roads barrier, the San Luis Pass barrier shall affect the Bay's hydrodynamics slightly in regular conditions. A decrease in flow area (constriction) will affect the tidal range



and tidal prism of the Bay, influencing the water circulation in the bay and thereby the ecosystem. We assume the same relation holds for San Luis Pass: if the flow opening in becomes less than 60% of the original, the Bay's ecosystem is adversely affected (Ruijs, 2011).

Furthermore we assume the subsoil conditions at San Luis Pass will be comparable to those at Bolivar Roads, i.e. consisting mainly of soft and firm clay layers, before reaching a strong bearing sand layer at MSL-40m. The storm surge barrier shall be designed to protect against surge levels with a return period of  $1/10,000 \text{ yr}^{-1}$ . Finally we use the requirement that the San Luis Pass should remain navigable for smaller vessels under normal conditions as a starting point. From the cross section in Figure 44 we learn the best navigation channel is at the southern end of the Pass.

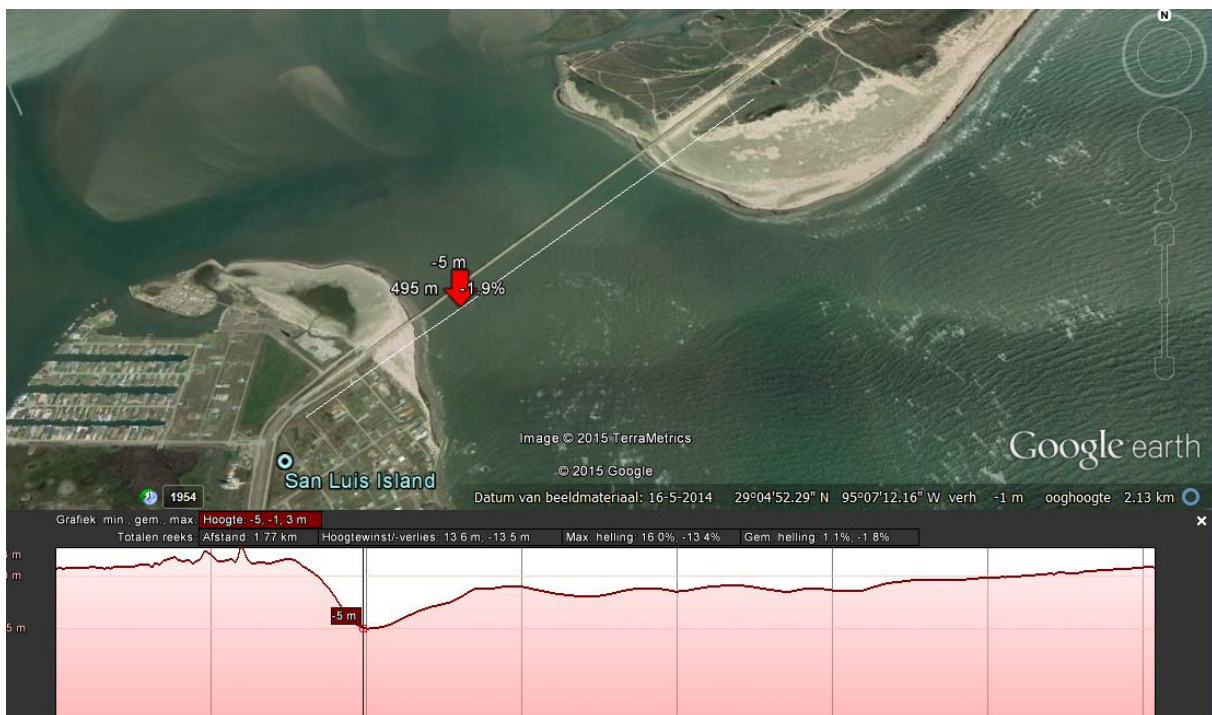

**Figure 44: Cross section of the San Luis Pass**

From this cross section we also learn that the Pass is pretty shallow for almost 80% of the opening, making it possible to close it off for most of its length and still satisfy the 60%/40% open/close ratio requirement. Leaving a navigable opening of around 50m X MSL -5m and an extra environmental barrier for another 150m-200m length, which is open under normal conditions, we are allowed to close off the last 750m-800m using a permanently closed barrier solution.

At first thought the existing San Luis Pass Bridge is a suitable "framework" for the barrier. It covers the whole Pass and already satisfies the navigational requirements. Using its foundations and load-bearing construction would reduce the construction costs significantly.

This bridge however was built shortly before 1970 though, meaning it reached a lifetime of 45 years by now. Moreover, it is highly unlikely the bridge was designed to withstand the enormous horizontal forces a closed bridge structure would face during a hurricane (these

forces will be multiple factors bigger than the horizontal forces the bridge will have to bear in the current open structure). In short, the San Luis Pass Bridge doesn't seem to be a good option for the barrier.

Looking at Figure 45, the most appealing option seems to be a new barrier close behind the San Luis Pass Bridge, where the opening is relatively short. Of course, better research should be done at a later stage to choose the final position of the barrier.



**Figure 45: San Luis Pass Bridge**

Next we take a look the barrier solutions. From Figure 46 we find the Bridge has a horizontal clearance of 57 ft. (17m) and a vertical clearance of 29 ft. (8.7m).



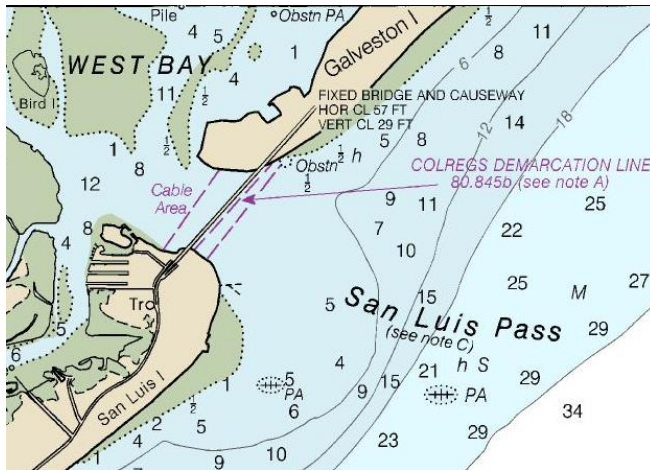
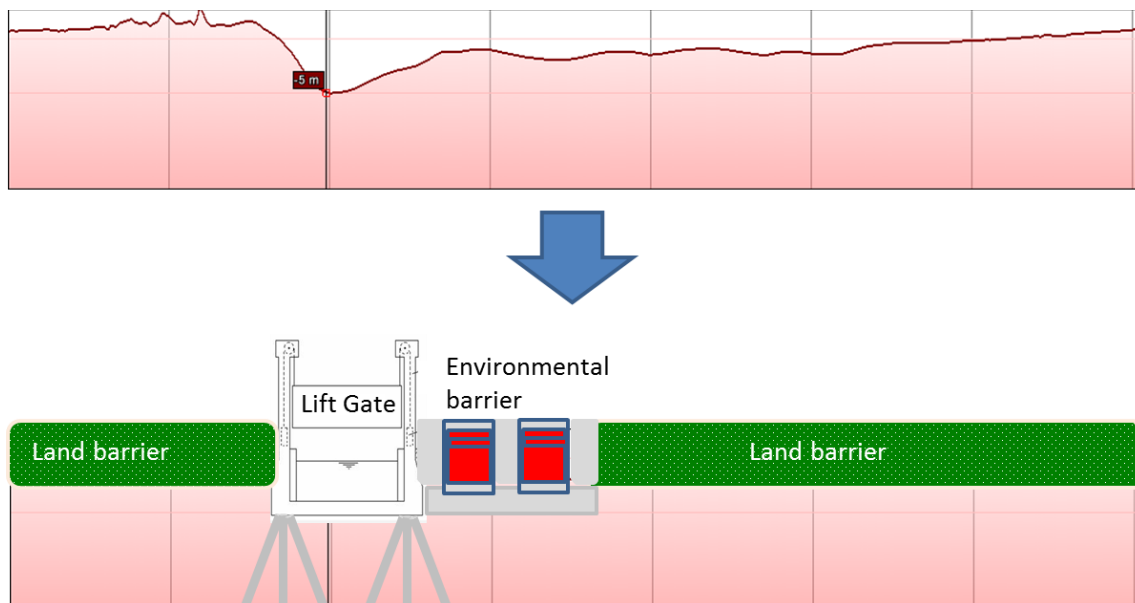

**Figure 46: San Luis Pass Navigation Chart**

For reasons of reliability and maintainability a vertical lift gate is a preferable option. It can be maintained (relatively) easily since all critical parts are above sea level. It is highly reliable since it can (almost) always be closed on gravity if all other drive systems fail, if designed wisely. The design decision whether to choose a hydraulic or mechanical drive system to move the lift gate can be made at a later stage.

This probably isn't enough to satisfy the 60% opening under normal conditions though. We propose to apply the same solution as for the environmental barrier at Bolivar Roads to semi-close the remaining opening of the San Luis Pass, for as much as it takes to satisfy the 60% opening requirement.

The remaining 40% of San Luis Pass can be closed permanently. To avoid heavy structures that need serious, and thus expensive, foundations, we propose to apply a land barrier for this part. It can be founded on the (firm) clay layer, giving the least expensive barrier with a "green look". This combination of solutions has been illustrated in Figure 47.



**Figure 47: Proposed San Luis Pass storm surge barrier solution**

## E: Land barrier

### Near shore wave height

The wave height given in Chapter 2: Hydraulic Boundaries accounts for offshore waves. As the wave progresses towards the land barrier, the waves change shape and height due to the shallow conditions nearshore. From the hydraulic boundaries can be seen that:

$$\begin{aligned}h_{nearshore} &= 5.2m \\H_{s,offshore} &= H_0 = 5.0m \\T_p &= 7.2m;\end{aligned}$$

Because the water depth decreases when the wave approaches the shore, the wave height will be affected by set-down and set-up. To calculate the effects and the resulting wave height at the land barrier, other information on the off-shore position is needed:

$$\begin{aligned}L_0 &= \frac{gT_p^2}{2\pi} = \frac{9.8 \cdot 7.2^2}{2 \cdot \pi} = 80.1 \text{ m}; \\c_0 &= \frac{L_0}{T_p} = \frac{80.1}{7.2} = 11.2 \frac{\text{m}}{\text{s}}; \\k_0 &= \frac{2\pi}{L_0} = \frac{2 \cdot \pi}{80.1} = 0,08 \text{ rad/m} \\ \alpha_0 &= 0 \text{ degrees ( wave perpendicular to coast )}\end{aligned}$$

In these calculations,  $L_0$  is the wave length in meter,  $c_0$  is the wave speed in meter per second,  $k_0$  is the wave number in rad/m and  $\alpha_0$  is the angle between the deep water wave crest and the shoreline. It is assumed that the offshore point is under deep water conditions, which needs additional measurements in a later stage. For this design step, deep water conditions are assumed to be sufficiently accurate. A schematization can be seen in Figure 48:

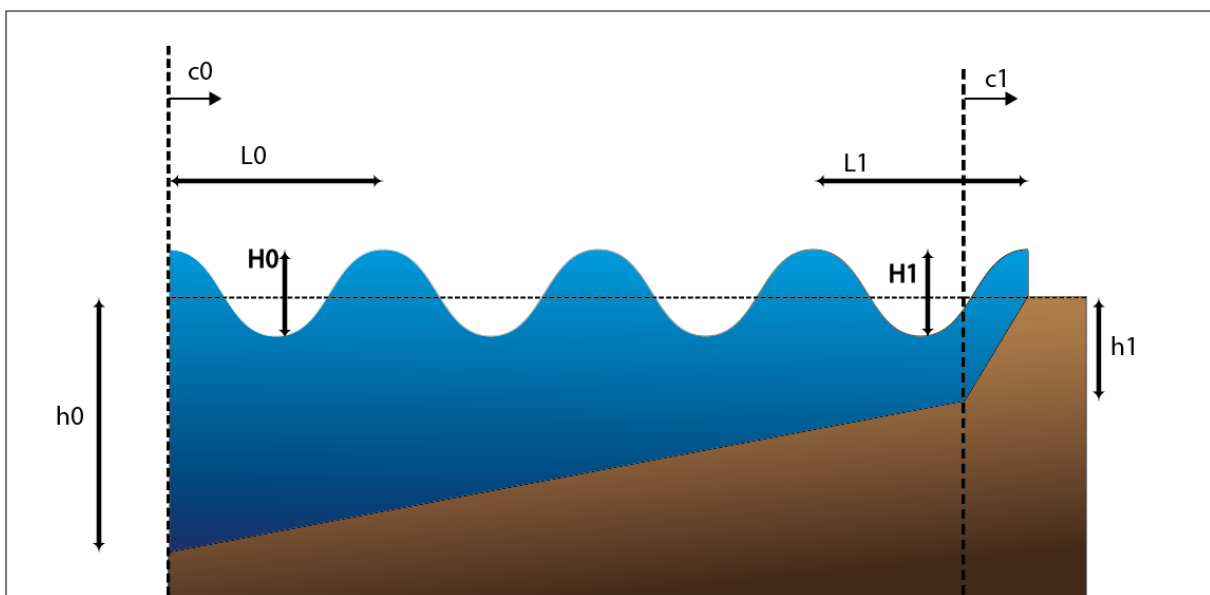

**Figure 48: schematization of wave calculation at deep water (situation 0) and shallow water (situation 1)**

The change toward shallow water conditions is based on the situation where energy flux is preserved, which is the amount of energy that passes through a certain point per unit of width. This only holds for non-breaking waves, which has to be checked later. The amount of either set-down or set-up is calculated with:

$$\frac{H_1}{H_0} = \frac{1}{\sqrt{\tanh(kd) \left(1 + \frac{2kd}{\sinh(2kd)}\right)}} = 0.98;$$

Where  $d$  is the water depth at the location of the barrier, which is 5.2 meter (17 ft.) due to the surge. This leads to:

$$H_1 = 4.92 \text{ m};$$

$$L_1 = L_0 \tanh(kd) = 47.9 \text{ m};$$

This will lead to breaking waves according to commonly used wave breaking limits ( $H_1/d > 0.6$ ).<sup>1</sup> The breaking wave will significantly reduce the wave height, which may result in the situation where a lower offshore wave will result in higher, non-breaking and more destructive waves nearshore. Whether this is the case, should be examined with the use of more detailed models in a later stage. In this stage, the wave breaking limits mentioned above are used.

The highest waves that comply with the wave breaking limits are assumed to be the most destructive waves and are therefore considered leading. These figures will be used in the conceptual design as stated in the main report:

$$H_{s,nearshore} = H_1 = 3.0 \text{ m}$$

$$L_1 = 47.9 \text{ m}$$

$$c_1 = \frac{L_1}{T_p} = 6.7 \text{ m/s}$$

---

<sup>1</sup> A second wave breaking limit ( $H_1/L_1 < 1/7$ ) does allow non-breaking waves under these circumstances.

## Land barrier design concepts

As a first step of design, the conceptual phase is used to find all possible solutions for the challenges that result from the hydraulic boundary conditions. Focussed on possibility and functionality rather than constructability and costs, this is meant to find the most creative solutions. From this first step, three most promising alternatives should emerge, which will be elaborated on further in a later phase. This phase can be found in the main report.

### Boundary conditions

The boundary conditions are based on a combination of hydraulic boundary condition and preferences of stakeholders, as communicated by Texas A&M University:

- Preferred barrier elevation is 17 feet +MSL (5.2 meters). This is equal to the existing Galveston seawall and represents the 1/100 year maximum water level.
- The land barrier should be overflow/overtopping resistant without catastrophic failure during 1/100 year conditions.
- A natural look or coverage is preferred.

The land barrier design will be based on 1/100 year conditions, which results in a water level of 5.2 m +MSL and 3 meter (10 ft.) waves.

### Possible Concepts

With these boundary conditions in mind, it is possible to generate concepts for the land barrier. The overview, which is shown below, is divided in three sections based on main levee design:

- Super Levee, which is a levee with a very gentle inner slope, based on Japanese design.
- Levee, which is a levee according to normal Dutch/US-standards
- Breakwater, which is a design that incorporates large stones in its main design

These three categories are in turn divided in multiple sections, mostly based on maximum crest height:

- 13 m (43 ft.), which is the calculated height for which no inner slope protection is needed
- 7.5 m (25 ft.), which is the calculated height for which natural inner slope protection could be sufficient
- 5.2 m (17 ft.), which is the height preferred as a boundary condition, based on the height of the Galveston Seawall

For each of these possible assumptions, several concepts are generated which should be able to perform its flood retaining function.

## 1. Super Levee

The first option is to construct the flood protection in the form of a Super Levee, which is an idea earlier constructed in Japan and partly in Galveston itself. The main property of a Super Levee is to construct a levee with such a gentle inner slope that breaching due to instability of the inner slope and piping are highly unlikely. This leads to levee with a large footprint, which needs large amounts of soil, but creates the opportunity to construct on top of the levee.

### 1.1 Safe Super Levee

This first concept constructs a Super Levee with a crest level of MSL +13 m (43 ft.). Properties:

- Low amounts of overtopping, which leads to a high amount of safety for the residents of the land masses
- No special inner bank protection needed, natural look can easily be constructed
- High costs due to large amounts of soil needed.

As a concept of the Safe Super Levee, two concepts were created:

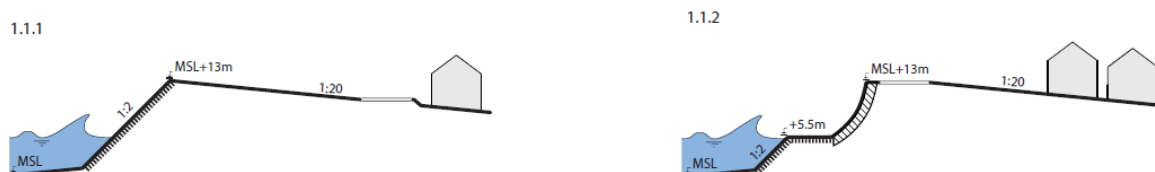

**Figure 49: Land barrier concept 1.1.1 and 1.1.2**

These concepts show differences at the gulf-side of the barrier. As the first alternative covers the outer bank with strong wave breaking, bank protecting elements, the second alternative adds a berm and a floodwall to counter the wave force.

### 1.2 Economic Super Levee

This concept constructs the Super Levee at a lower crest height of MSL +7.5m. Although this greatly limits the amount of soil needed, it will result in the necessity of inner bank protection.

- Relatively low amounts of overtopping, natural-looking inner bank protection sufficient
- Significant cost reduction compared to 1.1 due to required soil amount.

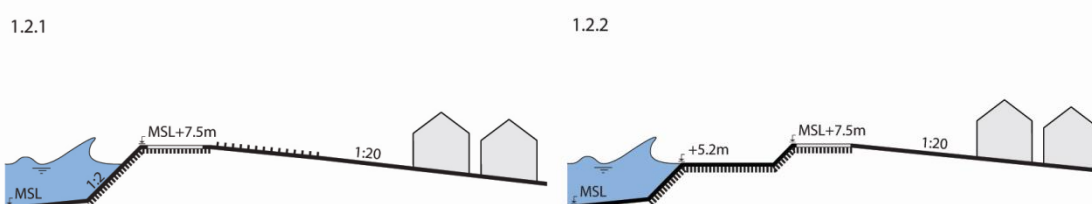

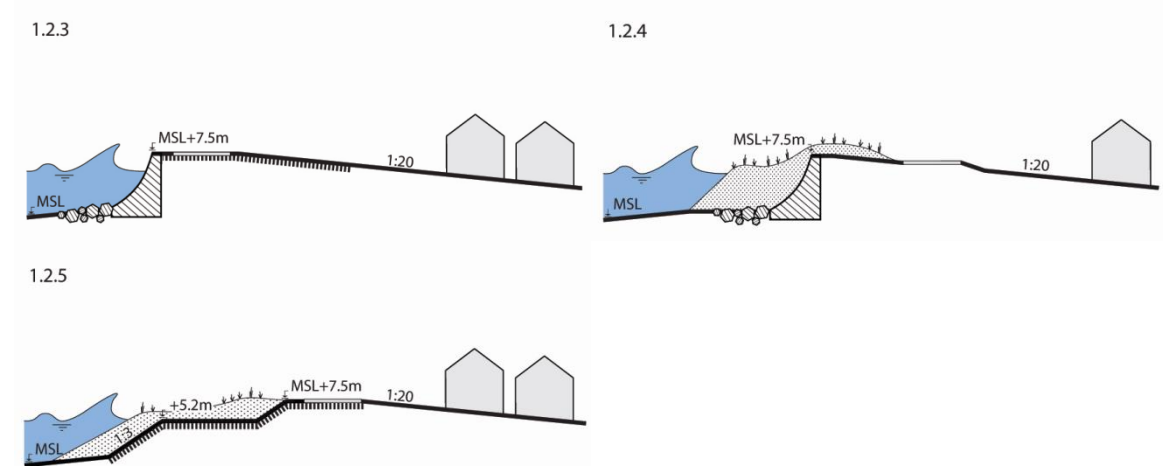

**Figure 50: Land barrier concepts for economic super levees**

These concepts show the many possibilities for this particular concept. The lower crest height makes the dike-in-dune concept a possibility because much lower costs of sand is involved compared to the 1.1-concepts. The other distinction is based on the gulf-side of the barrier. As was also the case in the Safe Super Levee, a concept is included with and without a berm. Also a concept with a single 7.5 meter (24.6 ft.) high floodwall is mentioned. The use of a berm limits the amount of inner slope protection needed. The use of a floodwall will lead to high construction costs compared to an earth levee.

### 1.3 Galveston-type Super Levee

The third form of Super Levee has a crest height of 5.2 meters (17 ft.), which is as high as the Galveston Seawall. This leads to a problematic situation where each wave will lead to overtopping or overflow. Combined with the 3 m (10 ft.) high waves, this leads to heavy inner bank protection requirements.

- Low crest height leads to high amounts of overtopping
- Small amount of soil required
- Very strong inner bank protection required

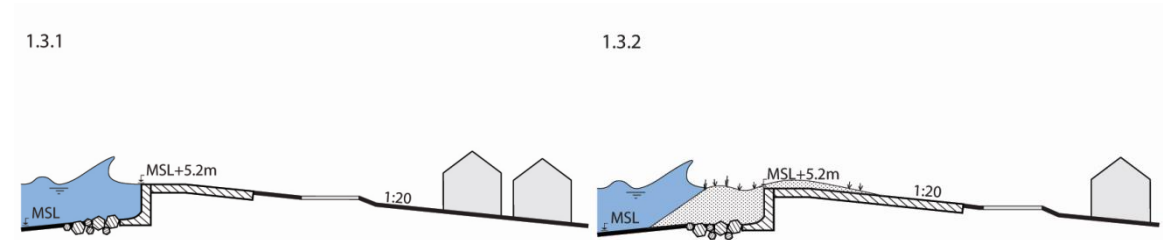

**Figure 51: Land Barrier concepts for Galveston-type Super Levees**

These concepts show an image very similar to the current Galveston Seawall. Using a design like the Galveston Seawall could lead to a higher amount of local support, as the iconic shape of the Seawall is preserved. Although large elements of inner slope protection are required, a dike-in-dune could be used to turn this structure into a natural looking beach during normal times.

## 2. Levee

The second form of design is the levee. This form has numerous similarities with the Super Levee, however the inner bank is much steeper. A slope of 1:2 to 1:4 is common, in contrast to 1:20 for the Super Levee.

### 2.1 Dutch dike

This alternative shows a high levee, which will lead to low amounts of overtopping. The smaller footprint will make living on the levee itself impractical, but limits the construction costs. Properties:

- Crest level at MSL +13m.
- Steep banks at both sides.

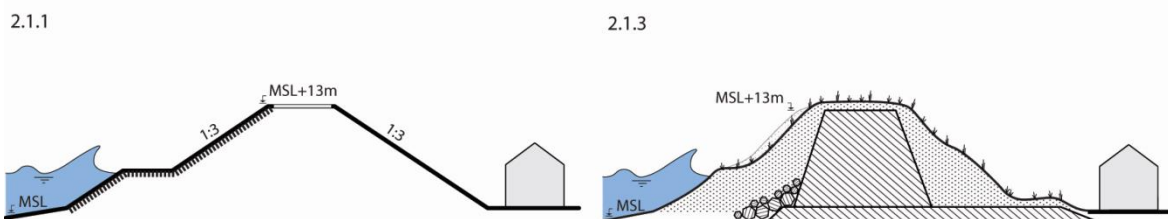

**Figure 52: Land barrier concepts for Dutch dike**

As shown above, there are several ways to address the challenge of the surge level and the waves. A special alternative shown is 2.1.2, which is basically a dune system. This will however require large amounts of sand, which is relatively expensive.

### 2.2 Economic levee

This alternative shows great resemblance to 1.2, although a steeper inner slope is used. This creates the opportunity to extend the dike-in-dune concept to cover the entire dike.

- Crest level at MSL +7.5m
- Less material needed than Super Levee alternatives

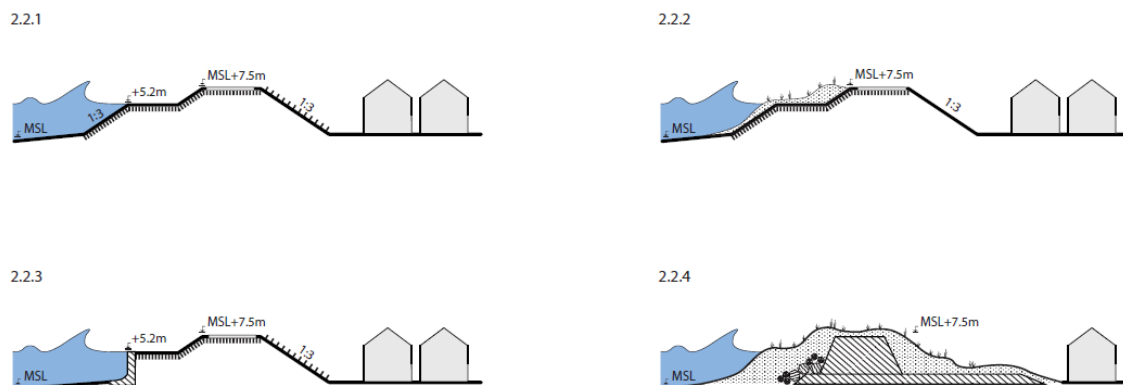

The different alternatives above show an interesting combination of height and strength. Overtopping is limited, protecting the lands directly behind the levee. The alternatives differ in the exact construction required, where 2.2.1 and 2.2.2 use an earth levee, which will most probably be cheaper than the other options, but need a larger footprint. 2.2.4 is an

interesting dike in dune alternative, where an entire impermeable, wave-resistant core is surrounded by a dune. During a storm this dune will disappear, combining safety in storm situations and a natural look in normal situations.

### 2.3 Galveston height levee

These alternatives combine the low Galveston seawall height with a small footprint. Although this will minimally affect the view and the lands, it will require large amount of bank protection on both sides of the crest.

- Large amounts of overtopping (order of 1000 L/m/s)
- Heavy bank protection needed

2.3.1



2.3.2

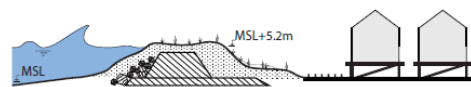

2.3.3

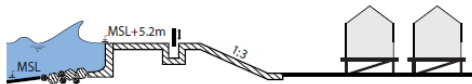

The illustrations above show the standard solution with a 5.2 meter high dike, heavily protected. Like was the case in earlier alternatives, it is possible to hide the heavy, non-natural constructions under a dune. As a third option, a moving barrier on the crest is proposed, which can be erected during storm conditions. This will limit the length of the bank protection required on the bay-side of the barrier.

### **Breakwater**

The third option to address the problems on the land barrier is to use a breakwater in your design. Breakwaters can be used to counter the large waves as a stand-in for bank protection. Another option is to use a separate breakwater to break the waves, while a different impermeable levee holds back the water surge.

- Large amounts of overtopping
- Easy to place
- Small, non-natural structures

The distinction between different alternatives is not based on height, but on location.



### 3.1 Stone levee

The Stone levee is a breakwater and levee in one. The core of the levee consists of a clay core, surrounded with sand. Around the sand, breakwater stones are provided to stop the waves. The thickness of the layer of stones and clay has to be determined in a later phase.

- Easy to construct, difficult to maintain
- Some protection needed on inside of the stone levee

The illustration below shows a main setup for this alternative.

3.1.1

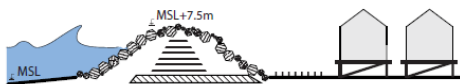

### 3.2 Breakwater+levee system

The most interesting use of a breakwater in the design of the land barrier is to combine it with a higher levee to counter the water surge. A strong disadvantage is the need for two constructions. However, the use of breakwater could lead to much lighter bank protection on the levee, making a natural look easier to construct.

- Breakwater dampens waves, levee holds back surge
- Natural look on levee easier to reach

3.2.1

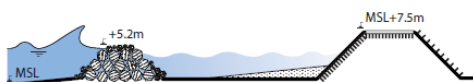

3.2.2

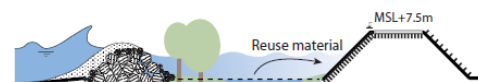

3.2.3

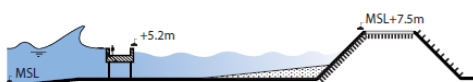

When looking at the three options above, it shows that these alternatives are rather different from each other. The first (3.2.1) is the easiest one, which is basically a beach with a breakwater in front of it. It limits the amount of bank protection needed on the levee itself and results in a very small footprint for the levee.

3.2.2 Tries to create a special zone between the breakwater and the levee. This is done by building the dike with material from the zone between the levee and the breakwater. This will limit costs and create a piece of land which is permanently under a shallow layer of water. This can be used as an additional natural zone. The beach will move from the levee to the outer side of the breakwater.

The third option also tries to dampen the waves, but tries to redesign the breakwater towards a multifunctional barrier. By construction a walking path on the storm design level, this can be used to stop the waves. In the case that no storm is coming, the path can be used for running or to get a good view of the surroundings.

### 3.3 Protective breakwater

The last alternative tries to provide the ultimate low-impact solution. By using a construction with a very small footprint and the lowest height limit of 5.2 meters, this will result in small constructions. This is mostly done by combining other ideas with a breakwater, with a small levee or floodwall on one side and a breakwater part on the other side.

- Large amounts of overtopping (in order of 1000 L/m/s)
- Small impermeable core

These solutions require strong bank protection far inland. This solution is mostly appropriate when the protection of the bay area is of important, as the structures on the land masses themselves will still be affected.

3.3.1

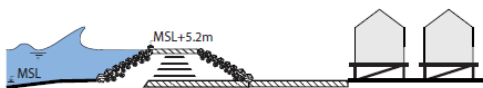

3.3.2



### Alternative phase

From these large amounts of alternatives, three most promising needs to be chosen. For the next phase, it is chosen not to choose based on individual aspects, as the alternatives show many similarities on a lot of factors. Instead, three different approaches are formulated and the best suited alternatives are used and elaborated on in the following phase.

These approaches are:

- Continuity and History, which is the alternative focussing on the best project integration with existing structures and flood defences. After comparing the different possible options, concept 1.3.1 is chosen as the most promising.
- Natural Safety, which will focus on the alternative which can provide a natural look while trying to comply with the boundary conditions as much as possible. The used concept will be 2.2.2.
- Seaward Protection, this alternative is meant to minimize the effects on the land masses themselves. For this alternative, concept 3.2.2 is seen as the most promising one, because of the additional natural land created and the small levee required.

## F: Cost estimate

The cost estimate is based on the preferred designs of the six construction elements of the barrier, consisting of three storm surge barriers and three land barriers:

- The Bolivar Roads Navigational Storm Surge Barrier
- The Bolivar Roads Environmental Storm Surge Barrier
- The San Luis Pass Storm Surge Barrier
- The Land Barrier on the Bolivar Peninsula, Galveston Island and along the Bluewater Highway

One should keep in mind that these components have been evaluated up to a different level of design, resulting in a different bandwidth in the cost estimate. This is affected further due to a difference in structural complexity. Below, every element of the Coastal Spine system is evaluated further individually in order to find the best cost estimate for that element specifically. Based on the underlying structural design and the method of cost estimation, a representable cost bandwidth will be determined. This will help to combine the costs into a single estimate for the total Coastal Spine system.

### Navigational barrier

The Bolivar Roads Navigational Barrier is the most complex component of the Coastal Spine system and has been evaluated in the most detailed design so far. The current preferred design consists of a barge gate and specially constructed scour protection across the entire width of the navigational channel.

The cost of the barrier is estimated according to two different methods. First, the type of barrier and the width of the total span are combined with knowledge from previous storm surge barrier-projects. (Mooyaart et al., 2014). A table with cost indications from this paper can be found below in Table 12. Secondly, the costs are estimated based on material quantities.

### Rule of thumb-method

The barge gate shows the largest resemblance with the Maeslant Barrier, which is a sector gate. Both barriers sway horizontally into the navigational channel, need complicated scour protection and need very specialized design for the hinge support. Also, the channels that need to be closed off have a similar depth (MSL-17m for the Navigation Barrier and -17m+NAP for the Maeslant Barrier). However, current information on Bolivar Roads show a difficult environment and leave many challenges, which will be accounted for by increasing the barrier costs with 25%. The Maeslant Barrier is shown to cost 670 million euros recalculated in 2014 currency. Combined with a 350-meter (1100 ft.) span, this leads to a cost per meter span of 1.9 million euros per meter span. The navigation barrier is therefore expected to cost 2.4 million euros per meter span.

When projected on the 200 meter (660 ft.) Navigational Barrier at Bolivar Roads, a cost of 475 million euros (550 million dollars) can be expected.

Storm surge barrier	Costs (C <sub>n</sub> )	Year (n)	Rate (r)	Exchange rate	Costs (C <sub>2014</sub> )	Costs per meter span
Eastern Scheldt	2360 M€	1986	2.5%	1.00	4602 M€	1.8 M€
St. Petersburg	4500 M€	2010	6.8%	1.20	6578 M€	3.6 M€
Venice	4700 M€	2011	3.0%	1.00	4986 M€	3.4 M€
Ems	290 M€	2002	2.7%	1.00	387 M€	0.9 M€
Thames	467 M€	1984	3.8%	1.20	1667 M€	4.5 M€
Maeslant	450 M€	1997	2.5%	1.00	668 M€	1.9 M€
Ramspol	100 M€	2002	2.8%	1.00	136 M€	0.7 M€
Eider	87 M€	1973	2.9%	1.00	275 M€	1.4 M€
Hartel	98 M€	1997	2.5%	1.00	145 M€	1.0 M€
IHNC <sup>3</sup>	550 M\$	2011	2.5%	0.74	425 M€	4.0 M€
Hollandsche IJssel	40 Mf	1956	4.0%	0.45	173 M€	2.2 M€
Seabrook	165 M\$	2011	2.5%	0.74	127 M€	2.2 M€
New Bedford	19 M\$	1966	4.8%	0.74	122 M€	2.7 M€
Hull	2,7 M€	1980	4.3%	1.20	19 M€	0.6 M€
Stamford	15 M\$	1969	4.8%	0.74	83 M€	3.1 M€

**Table 12: Cost indications of existing Storm Surge Barriers (Mooyaart et al., 2014)**

### **Material based approach**

The Rule of thumb-approach may give a first indication on the required costs, but is only partly based on the design of the Navigational Barrier itself. A cost estimate based on the used materials could improve the accuracy of the assumed costs. However, due to the many unknowns in the design of the barrier and the abutments in particular, this approach is assumed to be too inaccurate. Therefore, the navigational barrier costs that will be used for the total project costs estimate is only based on rule of thumb. Because of the large uncertainty, a bandwidth of 50% is used.

### **Environmental barrier**

The environmental barrier closes off the largest part of Bolivar Roads. The design that will be used for the cost estimate will hold the water back during storm surges with the use of sets of vertical lifting gates combined with a large shallow foundation.

### **Rule of thumb approach**

When costs need to be estimated with the use of reference projects, this particular component can best be compared with the Eastern Scheldt Barrier, although this barrier is built already 30 years ago. This means that design- and construction methods will probably have improved, especially because the Eastern Scheldt Barrier was the first storm surge barrier to be built on such a scale. With this in mind, it could still provide a good first estimate. The Eastern Scheldt Barrier is calculated to costs around 1.8 million euros per meter span length. As the Bolivar Roads Environmental Barrier is 2800 meter (1.7 mile) long, this will lead to a first estimate of 5.0 billion euros (5.8 billion dollar).

### **Material based approach**

The structural design of the environmental barrier was relatively detailed, which means that a more detailed cost estimate can be made than for example the land barrier. Because the large amount of repetition in the environmental barrier, a larger portion of the costs will come from the costs of the material themselves. The largest amount of costs will result from the structural elements, but also the temporary works are important. Which amount is related to which part of the design, can be found in Appendix F.1. The most important structural elements can be found below in Table 13.

<b>Component</b>	<b>Material</b>	<b>Amount</b>	<b>Material costs</b>	<b>Component costs</b>
<b>Tower/pillars</b>	Concrete	5220 m <sup>3</sup>	\$635/m <sup>3</sup>	3.3 M\$
<b>Lifting Gates</b>	Steel	26640 ton	\$8000/m <sup>3</sup>	213 M\$
<b>Footplate</b>	Concrete	441000	\$420/m <sup>3</sup>	185 M\$
<b>Bed Protection</b>		1176000 m <sup>3</sup>	\$105/m <sup>3</sup>	124 M\$

**Table 13: Main structural elements of the Bolivar Roads Environmental Barrier**

These material costs are the basis for the total estimated costs of the Environmental Barrier, together with the costs for temporary works, overhead and unforeseen risks among others. The detailed estimate can be found in Appendix F.1.

The material based approach estimates the costs to be 1.8 billion dollar, which is considerably lower than the rule of thumb-approach. An explanation could be that the environmental section of Bolivar Roads is much shallower than the Easter Scheldt, which results in lower towers and less material needed. The costs of the Easter Scheldt Barrier could also have increased due to large amount of innovative and specialized material needed for the barrier in that time. However, previous projects are often a good indication of the total costs.

With these considerations in mind, total project costs less than the rule of thumb approach is chosen with a large bandwidth. The Environmental Barrier is estimated to cost 4.0 billion dollars with a 50% bandwidth.

### **San Luis Pass barrier**

The barrier in the San Luis Pass is a combination of three types of barrier. The largest part of the barrier consists of an earth levee, which does not need to have the same dimensions as the land barriers. The deepest part of the current San Luis Pass is used for ship traffic and can be closed off with a lift gate. The remaining span is able to be closed off with the use of an environmental barrier. Therefore, the cost estimate will also be divided, mostly based on rule of thumb.

The costs can be seen in Table 14. The cost of the lift gate is based on the costs of the Eastern Scheldt barrier, which used the same mechanism. The environmental part is based on the estimate of the Environmental Barrier estimate above and the Earth levee is based on (Jonkman et al., 2013c), which is further explained in the cost estimate of the Land Barrier.

**Table 14: San Luis Pass cost estimate**

<b>Element</b>	<b>Length</b>	<b>Component costs</b>	<b>Estimated component costs</b>
<b>Lift gate</b>	50 m	2.1 M\$/m	105 M\$
<b>Environmental barrier</b>	150 m	1.4 M\$/m	210 M\$
<b>Earth levee</b>	800 m	17 M\$/km	15 M\$
<b>Total</b>			<b>330M\$</b>

From the table above can be concluded that the costs of the San Luis Pass Barrier is estimated to be 330 million dollar. A more detailed cost estimate can be made in a later stage, when the exact elements and their dimensions are known. As this is only based on rule of thumb, a large bandwidth is chosen at 50%.

### Land Barrier

The land barrier is the largest part of the protective coastal spine. It consists of three parts:

- Bolivar Peninsula
- Galveston Island
- Bluewater Highway

Together, the barrier on these three land masses spans for roughly 90 kilometer (56 mile). The cost estimate is based on the preferred alternative, which consisted of a 5.2 meter (17 ft.) high floodwall and a gentle, clay/sand inner slope. The costs of this large element of the coastal spine system are not based on complexity, but depends more on its size. It is therefore important that the length of coast along which the barrier spans is calculated as detailed as possible.

The length of the barrier on the Bolivar Peninsula spans from the north point of Environmental Barrier on Bolivar Roads along the coast in North-eastern direction for 40 km up to the point where the road turns further inland towards High Island.

The barrier on Galveston Island connects the existing Galveston Seawall with the barrier on the San Luis Pass, nearly 30 km towards the Southwest.

South of the San Luis Pass a choice has to be made. If a design storm hits, the lands south of the San Luis Pass will flood, especially with the barriers in place. It is therefore chosen to extend the land barrier in South-western direction up to Freetown, which adds another 20 km of land barrier protection.

The costs of the preferred alternative are estimated with the use of two calculation methods, which will be compared later. First the rule of thumb-method will try to estimate the land barrier costs based on previous projects. Subsequently, a material based analysis is used to provide an estimate which will show the consequence of the current design decisions.

### Rule of Thumb

This method is mostly based on the costs and experiences of previous projects. As stated in (Jonkman et al., 2013c), it should be possible to make a rough estimate of the costs of

raising a flood defense by comparing the planned construction with costs of earlier works in the United States (New Orleans) and the Netherlands.

Especially the comparison with the projects in New Orleans is interesting, as most components of the planned preferred alternative (A concrete floodwall combined with an earthen levee on the protected side) are also used for the flood defense of New Orleans.

For the 'rule of thumb'-approach, the construction will be divided between two well-known structures. Close to the sea, the costs will be based on the costs of a floodwall. Behind the floodwall, the gently-sloped clay/sand backfill is modelled as half of an earth levee.

The table below shows a very rough estimate for the costs of the dike. It relies on the findings of (Jonkman et al., 2013c), which states that a floodwall will cost approximately 6-11 million dollars in order to raise one kilometer of floodwall for one meter compared to the old situation. In this particular situation, a component cost of 7 M\$/km/m is chosen, because the building site is easily accessible and needs only minor adjustment before placement. The floodwall elements can most likely be constructed nearby in the Galveston Bay Area.

The bay-side of the floodwall is filled with clay and sand under a gentle slope. Because of the relatively gentle slope and the use of sand, which is not obtainable close by, a cost of 2.3 M\$/km/m is chosen.

The results can be found in the table below. Because this is a very rough estimate, it should not be used for any other purpose than to clarify the order of magnitude.

**Table 15: Cost estimate for land barrier based on rule of thumb**

Element	Length	Height	Component costs	Estimated component costs	estimated costs per km
<b>Floodwall</b>	90 km	5.2 m	6-11 M\$/km/m	7 M\$/km/m	36.4 M\$
<b>Earth levee (half)</b>	90 km	5.2 m	1.5-3.0 M\$/km/m	2.2 M\$/km/m	11.4 M\$
<b>Total</b>					<b>47.8 M\$</b>

These figures can be compared to the costs of the New Orleans Floodwall. This floodwall is estimated at 20-40 M€/km, which agrees rather well with the estimated costs per km of the floodwall in this project (36.4 M\$ or 31.2 M€).

The findings show that a total cost per km for the land barrier can roughly be estimated at \$47.8 million per kilometer according to the rule of thumb-approach.

### Material Based approach

The land barrier is composed out of often used materials and construction methods. Therefore, it is possible to construct a relatively detailed cost estimate based on materials. With the use of the chosen cross section, the amount of sand, concrete and clay are calculated. The detailed calculation can be found in Appendix F.1.

The calculations show that a total construction cost of 3.6 billion dollars can be expected for the 90 kilometer land barrier, where the largest costs result from the floodwall and the heavy bed protection. Per kilometer this is estimated to be 40.1 million dollars, which is rather close to the rule of thumb approach (47.8 M\$/km). The total estimate for the land barrier is chosen to be 4.1 billion dollars with a 30% bandwidth. Please note that this estimate is based on the current design, which can be subjected to large changes in later phases.

### Coastal spine cost estimate

When all components are added, the cost estimate for the total project can be calculated. The calculation can be seen in Table 16.

**Table 16: Coastal Spine cost estimate**

Element class	Location	Length	Partial costs	Element costs	Bandwidth
<b>Storm Surge Barrier</b>	Bolivar Roads (Navigational)	200 m	2.75 M\$/m	550 M\$	50%
	Bolivar Roads (Environmental)	2800 m	1.4 M\$/m	4,000 M\$	50%
	San Luis Pass	1000 m	-	330 M\$	50%
<b>Land Barrier</b>	Bolivar Peninsula	40 km	45 M\$/km	1,800 M\$	30%
	Galveston Island	30 km	45 M\$/km	1,350 M\$	30%
	Bluewater Highway	20 km	45 M\$/km	900 M\$	30%
<b>Total</b>				<b>8,930 M\$</b>	<b>40%</b>

The cost estimate shows an estimated project costs between 5.2 B\$ and 12.4 B\$. This results in an estimate of 8.9 billion dollars with a bandwidth of 40%.

A couple of notes should be kept in mind:

- The cost estimate is based on current design assumptions. Many different designs, particularly the land barriers, can be adjusted significantly.
- Because of the early stage of design, the costs are mostly based on previous projects. In a later stage, when the main dimensions of the Coastal Spine are known, a more accurate cost estimate with a smaller bandwidth is possible.
- At the south end of the San Luis Pass, a land barrier along the Bluewater Highway is placed to totally close of the Galveston Bay Area from the Gulf during storm conditions. Other choices at this position could lead to other costs.



### **F.1 Calculation Sheets**

Below are shown the cost estimate for the:

- Environmental Barrier
- Land Barrier

**Table 17: Bolivar Roads Environmental Barrier cost estimate**

Specification	Quantity	unit	PPU	Total
INPA 130336 TUD Reconnaissance Study Houston SS barrier				
Galveston Island / Goat Island				
Shallow Foundation with Vertical Lifting Gates				
<b>Temporary Works</b>				
Acquiring site construction Dock	110000	m2	\$145,00	\$15.950.000,00
Establishment costs construction dock	110000	m2	\$290,00	\$31.900.000,00
Utilities ( water electra etc. )	1	unit	\$9.487.500,00	\$9.487.500,00
Infrastructure / Housing etc.	1	unit	\$6.325.000,00	\$6.325.000,00
Maintenance / Operational costs	150	weeks	\$632.500,00	\$94.875.000,00
Equipment ( cranes / tugboats / excavators etc. )	10	units	\$10.000.000,00	\$100.000.000,00
Transport costs on-site construction dock	98	units	\$15.000,00	\$1.470.000,00
Transport dock-site to barrier site	98	units	\$250.000,00	\$24.500.000,00
Construction dock works in order tot transportation units	25	time	\$500.000,00	\$12.500.000,00
Temporary structures conostruction dock	1	unit	\$2.000.000,00	\$2.000.000,00
<b>Structurial works</b>				
Footplate ( incl. concrete, rebar, formwork )	441000	m3	\$420,00	\$185.220.000,00
Tower / pilars ( incl. concrete, rebar, formwork )	5220	m3	\$635,00	\$3.314.700,00
Steel lifting gates ( coated / precasted )	26640	ton	\$8.000,00	\$213.120.000,00
<b>Bed Protection</b>				
Bed Protection ( heavy duty, incl. dredging works ))	1176000	m3	\$105,00	\$123.480.000,00
<b>Additional work environmental barrier</b>				
Installations lifting gates ( hydraulic cilinders / drive / control )	48	units	\$1.875.000,00	\$90.000.000,00
Housing / protectionunits installations	49	units	\$250.000,00	\$12.250.000,00
Piping / Powerunits etc.	2800	m1	\$5.000,00	\$14.000.000,00
Connections Mainland / Navigational Barrier	4	units	\$2.500.000,00	\$10.000.000,00
<i>Subtotal Directe Kosten</i>				<i>\$950.392.200,00</i>
Incomplete design	25	%	\$950.392.200,00	\$237.598.050,00
<b>Total Direct Construction Costs</b>				<b>\$1.187.990.250,00</b>
Construction site costs ( barrier location )	10	%	\$1.187.990.250,00	\$118.799.025,00
Overhead - Directional costs contractor	8	%	\$1.306.789.275,00	\$104.543.142,00
Profit	5	%	\$1.306.789.275,00	\$65.339.463,75
<b>Total Indirect Costs</b>				<b>\$288.681.630,75</b>
<b>Total Estimated Costs ( TDC + TIC )</b>				<b>\$1.476.671.880,75</b>
Unforeseen Project Risks	25	%	\$1.476.671.880,75	\$369.167.970,19
<b>Total construction costs</b>				<b>\$1.845.840.000,00</b>
sed on the following premisses and starting-points :				
Environmental barrier length	2800	m1		
Span of lifitng gates	50	m1		
Concrete elements are precasted in construction dock	49	units		
Transported and placed on location ( Pilars and Footplates )				
Steel doors are lifted by a hydraulic system	144	units		
Steel doors precasted in workshop				
Steel doors transported and placed on location				
Bed protection width on both sides	140	m1		
Thickness Bed Protection	1,5	m1		

**Table 18: Coastal Spine Land Barrier cost estimate**

	Specification	Quantity	unit	PPU	Total
<b>05</b>	<b>Texas Landbarrier</b>				
05.01	Sand embankment ( incl. procurement, transport )	12150000	m3	\$14,00	\$170.100.000,00
05.02	Clay Embankment ( incl. procurment, transport )	22500000	m3	\$12,00	\$270.000.000,00
05.03	Rock Fill	675000	m3	\$70,00	\$47.250.000,00
05.04	Bed Protection ( heavy duty, concrete slabs )	4500000	m2	\$90,00	\$405.000.000,00
05.05	Asphalt roadwork on top of landbarrier	900000	m2	\$60,00	\$54.000.000,00
05.06	Steel sheetwall concrete wall	900000	m2	\$160,00	\$144.000.000,00
05.07	Concrete foundation piles	54000	units	\$1.250,00	\$67.500.000,00
05.08	Concrete wall elements ( incl. concrete, rebar, formwork, placed )	1350000	m3	\$520,00	\$702.000.000,00
	<i>Subtotal Directe Kosten</i>				<i>\$1.859.850.000,00</i>
	Incomplete design	25 %		\$1.859.850.000,00	\$464.962.500,00
<b>TDC</b>	<b>Total Direct Construction Costs</b>				<b>\$2.324.812.500,00</b>
	Construction site costs ( barrier location )	10 %		\$2.324.812.500,00	\$232.481.250,00
	Overhead - Directional costs contractor	8 %		\$2.557.293.750,00	\$204.583.500,00
	Profit	5 %		\$2.557.293.750,00	\$127.864.687,50
<b>TIC</b>	<b>Total Indirect Costs</b>				<b>\$564.929.437,50</b>
	<b>Total Estimated Costs ( TDC + TIC )</b>				<b>\$2.889.741.937,50</b>
	Unforeseen Project Risks	25 %		\$2.889.741.937,50	\$722.435.484,38
	<b>Total construction costs</b>				<b>\$3.612.177.500,00</b>
<b>Additional costs in order to come to a total of investment costs</b>					
	Engineering total project	4 %		\$3.612.177.500,00	\$158.935.810,00
	Overhead Ordering Party	3 %		\$3.612.177.500,00	\$119.201.857,50
	Permits, Insurance etc.	2 %		\$3.612.177.500,00	\$79.467.905,00
	Supervision & Oversight / Verification	1 %		\$3.612.177.500,00	\$39.733.952,50
	Communications costs / Publicity ( Indicative numbers )	0,1 %		\$3.612.177.500,00	\$3.973.395,25
Estimation is based on the following premisses and starting-points :					
	* Texas Land Barrier length ( Bill of Quantity )	90000	m1		
	* Steel sheet wall ( 120kg/m2 )				
	* Concrete foundation piles ( #400mm Length 15m )				
	* Concrete wall elements precasted				

## G: Technical recommendations

A list of mostly technical recommendations is given in the following bullets. These recommendations have been categorized by theme.

### Protection levels and hydraulic boundary conditions

- Pragmatic choices for the protection levels for the initial design have been made in this study. Further investigation and optimization of **protection levels** is highly recommended, also taking into account the uncertainty of the hydraulic boundary conditions. This can be done based on a so-called cost benefit analysis or economic optimization. In such an approach the additional costs of better protection vs. risk reduction benefits are considered and optimized. Criteria for risk to life can also be considered as a basis for design. A risk model needs to be developed to support this process.
- A particular challenge is to **optimize the elevation and performance of various elements** in a coherent way both at the system and element level. Important design parameters include the elevation of (and overflow over) the storm surge barriers, and the elevation of the land barrier and its ability to withstand significant overflow. The Galveston Bay system can “buffer” some inflow during extreme events and tolerable overflow and leakage levels have to be identified. A key question is where and how overflow and inflow is allowed over certain elements. It should be further investigated – by coupling with hydraulic models – which configurations of elements leads to acceptable surge and risk levels in the bay at a certain cost. A key recommendation is to set up such as optimization model by coupling hydraulics, engineering of the elements and cost functions.
- In this report pragmatic choices for **hydraulic boundary conditions** for the design have been used, based on available information from past studies and expert judgement. It is recommended to improve these estimates based on the results of the more recent storm surge modelling work. This work has to be incorporated in a probabilistic framework to allow derivation of return periods.

### Land barrier

- Initial concepts for the **land barrier** have been developed. These need further investigation and optimization with respect to costs, engineering performance and landscape integration. More specifically the following needs to be considered:
  - Landscape integration and incorporation and adaptation of **existing (and new) buildings**. This could be done by studying a number of representative cross sections.
  - **Edges of the land barrier**: in a conservative approach it has been assumed that at both the western and eastern ends significant stretches of the land barrier are needed to close the bay. This requires further optimization and investigation, also utilizing the outputs of surge models to investigate the effects of inflow on water levels in the bay.

- Initial designs at a “**sketch level**” have been made. Further optimization of the land barrier profile, taking into account material costs, implementation issues etc. will be required.

### Storm surge barriers

- Several possible concepts for the **environmental section** of the Bolivar Roads barrier have been identified. The most promising concept seems a system with vertical lifting gates or radial gates and this requires further engineering and evaluation.
- The **barrier foundation** and abutments of the navigational gate comprises a major challenge.
- The design of the barge gate in the navigational section as a floating structure leads to very high costs due to the required scour protection. Reconsidering the design in the direction of a closed gate could lead to cost savings in the required scour protection.
- Preliminary analyses of the barrier **operation, dynamics** have been performed. Further investigation, including scale model tests, is recommended. Key design features include the hinge and scour protection.
- More data and information is required, especially more **geotechnical information** on soil conditions, and information on **return periods of hydraulic loads** (surge and waves) based on the modelling of large suite of storms with and without various spine configurations.
- An initial design of the San Luis Pass barrier has been made which could require further optimization and inputs of local stakeholders.

### General

- It will be key to develop a system for **funding, management and maintenance** of the coastal spine. The ability of the asset managers to maintain the barrier will have a major effect on its reliability.

The effects of the barriers on other functions need to be incorporated in the design

- **Environmental changes** of proposed Coastal Barrier strategy have to be evaluated using models for water quality and environmental effects. Insights need to be fed back into the design.
- Public perception and support of this strategy needs to be further elaborated. Also, impacts on other functions in the region (**navigation, fisheries, recreation**) must be further assessed.
- Finally, the investigations in this report have focused on elements of the coastal spine. Due to the nature of the hurricane surge in Galveston Bay **additional risk reduction features** could be required. Examples of elements that deserve further study include wetlands and oyster reefs within the bay, a back side levee at Galveston Island against the inner bay surge and perimeter or mid bay protection for high risk areas of Houston with levees and barriers. These investigations could feed into a plan for a multiple lines of defence system.