

Tomáš  
**POJETA**



2004 - 2023

**Creative & Art Direction / Idea Making / Visual Communication**

Graphic Design & Storytelling / Branding / Motion & Video

A stylized, hollow letter 'A' with a gradient from orange at the top to red at the bottom.

**Logo & Brand Design,  
Corporate Identity & Visual Communication,  
Motion & Video Direction**

A stylized, hollow letter 'B' with a gradient from purple at the top to pink at the bottom.

**Digital Design,  
UX & Ui,  
Data Visualization**

A stylized, hollow letter 'C' with a gradient from purple at the top to blue at the bottom.

**Creative Webdesign,  
Illustration,  
Visual Storytelling**

EPICRIDE

LISTER

CITY  
HIT

REDMA

HOKOSOFT

ip fabric

ace

mtp  
INVESTMENT FUNDS

Stránky.cz

SLEVOMAT

featherclick

IRIS

A

**Logo & Brand Design,  
Corporate Identity & Visual Communication,  
Motion & Video Direction**

BAZÉNY3000

caree

socialbakers

engage

cookie lab

VEJMINEK

PMP  
INVESTMENT GROUP

k<sup>ch</sup>

coproni?

08

Hypnosechny.cz

3

EPICRIDE



REDMA



HOKOSOFT

ip fabric



SLEVOMAT



BAZÉNY3000



VEJMI NEK



Hyprousechny.cz



*new*  
**PRIAM**



VISUAL CONCEPT & GRAPHIC DESIGN

# E-PRIAM Teaser



CONCEPT & STORYBOARD  
VISUAL & MOTION DESIGN

▶ PLAY VIDEO

# PRIAM & MIOS Reveal



VISUAL CONCEPT  
CREATIVE DIRECTION

▶ PLAY VIDEO

# PASSION for EXCELLENCE



VISUAL CONCEPT  
CREATIVE DIRECTION

▶ PLAY VIDEO

# SENSORSAFE



CONCEPT & STORYBOARD  
VISUAL & MOTION DESIGN

▶ PLAY VIDEO

# LEMO



CONCEPT & STORYBOARD  
VISUAL & MOTION DESIGN

▶ PLAY VIDEO



## E-PRIAM PRODUCT VIDEO

CONCEPT & STORYBOARD  
MOTION DESIGN  
CREATIVE DIRECTION

▶ PLAY VIDEO



## SENSORSAFE LIFESTYLE / PRODUCT VIDEO

CONCEPT & STORYBOARD  
MOTION DESIGN  
CREATIVE DIRECTION

▶ PLAY VIDEO



## E-PRIAM IN-STORE PRODUCT CONFIGURATOR

▶ [PLAY VIDEO](#)

**NEW PRODUCT CONCEPT & PRESENTATION PITCH**  
**VISUAL & MOTION DESIGN**

**cybex**



# DRIVERAMA

DELIVERY TRUCK WRAP DESIGN

PR PHOTO CO-PRODUCTION & RETOUCHING



CAUTION!  
Contains small parts!  
Choking hazard!

AGE 18+  
SIZE 1:1

🚫 🗑️ 🔊

DRIVERAMA

D

DRIVERAMA



DRIVERAMA

CAUTION!  
Contains small parts!  
Choking hazard!

AGE 18+  
SIZE 1:1



DRIVERAMA  
Fair buying. Fair selling.

www.driverama.de

V 21003

# DRIVERAMA

BRAND'S DESIGN LANGUAGE EVOLUTION

PHOTO RETOUCH & POSTPRODUCTION

BRAND VISUALS CREATION & IMPLEMENTATION



**Inzahlungnahme  
ohne Drama?**  
Das ist fair.



**DRIVERAMA**  
Fair buying. Fair selling.

**Transparente  
Inspektionen?**  
Das ist fair.



**DRIVERAMA**  
Fair buying. Fair selling.

**Bequeme Lieferung  
nach Hause?**  
Das ist fair.



**DRIVERAMA**  
Fair buying. Fair selling.

**Autokauf  
von der Couch aus?**  
Das ist fair.



**DRIVERAMA**  
Fair buying. Fair selling.

**Auto-Finanzierung,  
ganz simpel  
und transparent?**  
Das ist fair.



**DRIVERAMA**  
Fair buying. Fair selling.

**Kein Stress  
beim Autokauf?**  
Das ist fair.



**DRIVERAMA**  
Fair buying. Fair selling.

**15 Tage volle  
Geld-zurück-Garantie?**  
Das ist fair.

15



**DRIVERAMA**  
Fair buying. Fair selling.

**Gebrauchtwagenkauf  
als 5-Sterne-Erlebnis?**  
Das ist fair.

★ Trustpilot  
★★★★★  
Trustscore 5/5: Hervorragend



**DRIVERAMA**  
Fair buying. Fair selling.

**Zulassung  
schon erledigt..**  
Das ist fair.



**DRIVERAMA**  
Fair buying. Fair selling.

**Stressfreie  
Inzahlungnahme?**  
Das ist fair.



**DRIVERAMA**  
Fair buying. Fair selling.

**Mehr als 1 000  
durchgecheckte  
Autos zur Auswahl?**  
Das ist fair.



**DRIVERAMA**  
Fair buying. Fair selling.

**Komplett startklare  
Gebrauchtwagen?**  
Das ist fair.



**DRIVERAMA**  
Fair buying. Fair selling.

**Auto verkaufen in  
höchstens 59 Minuten?**  
Das ist fair.



**DRIVERAMA**  
Fair buying. Fair selling.

**Gratis Taxifahrt  
nach Hause?**  
Das ist fair.

TAXI



**DRIVERAMA**  
Fair buying. Fair selling.

**Inspektion  
mit 250 Prüfpunkten?**  
Das ist fair.



**DRIVERAMA**  
Fair buying. Fair selling.

**ONLINE & OFFLINE BRAND COMMUNICATION**

# DRIVERAMA

## LIFESTYLE / PRODUCT VIDEO

CONCEPT & STORYBOARD

CREATIVE DIRECTION

MOTION DESIGN

▶ PLAY VIDEO



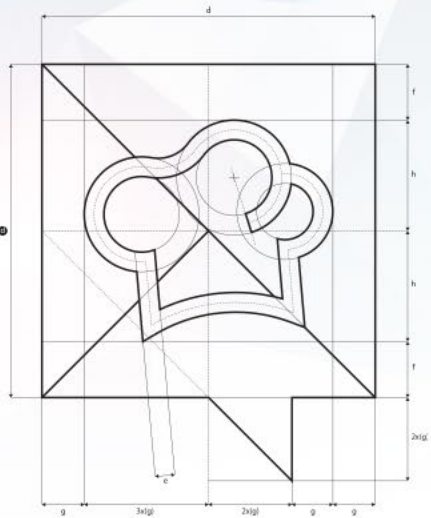

**CONCEPT & STORY**  
**VISUAL DESIGN**  
**MOTION DIRECTION**

▶ **PLAY VIDEO**



**CONCEPT & STORYBOARD**  
**CREATIVE DIRECTION**

▶ **PLAY VIDEO**

# SOCIAL MEDIA MINUTE

with Jan Rezab

**VISUAL DESIGN**  
**MOTION DIRECTION**

**YOUTUBE CHANNEL**

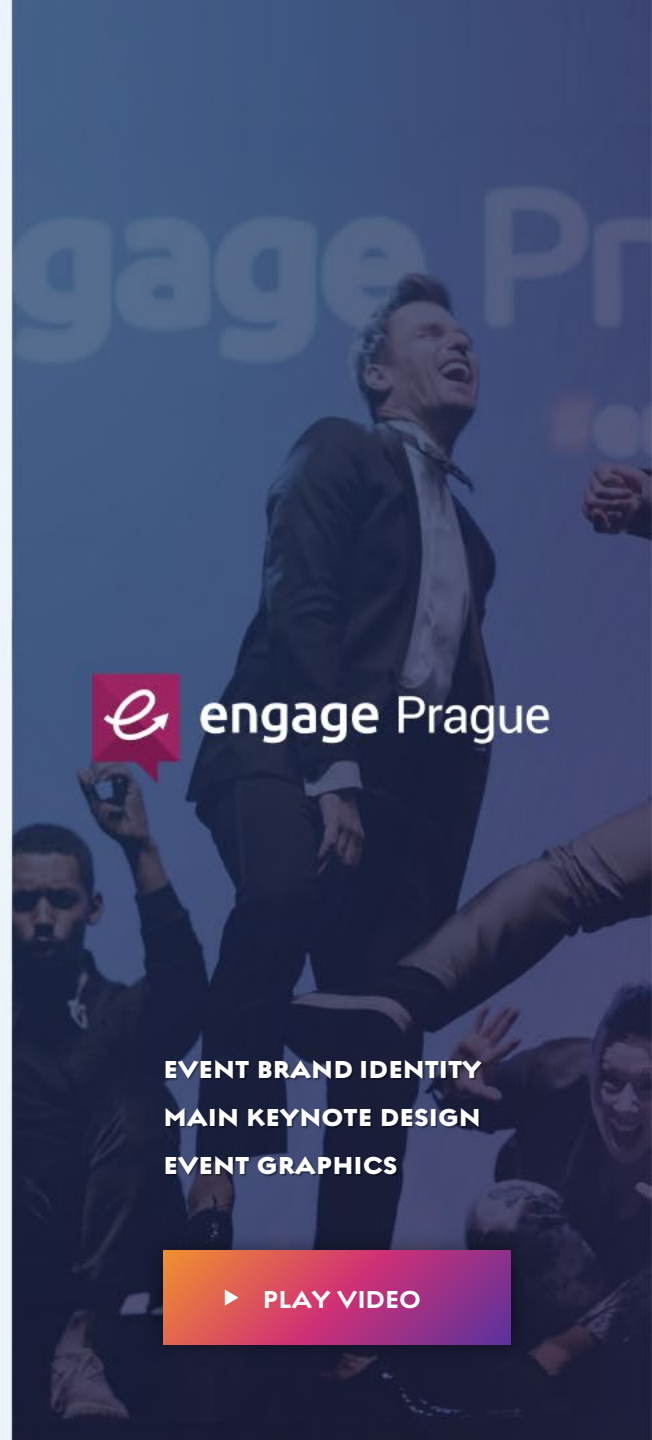

 **engage Prague**

**EVENT BRAND IDENTITY**  
**MAIN KEYNOTE DESIGN**  
**EVENT GRAPHICS**

▶ **PLAY VIDEO**

B

Digital Design,  
UX & Ui,  
Data Visualization



+ 120 %

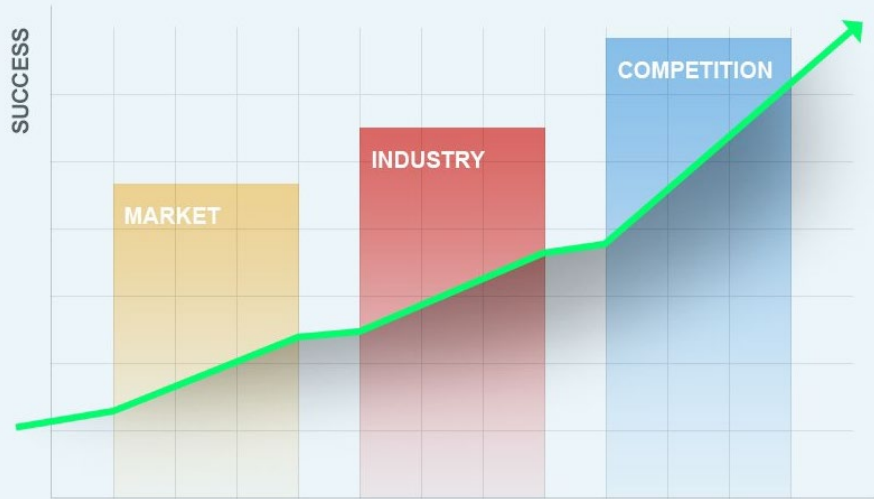
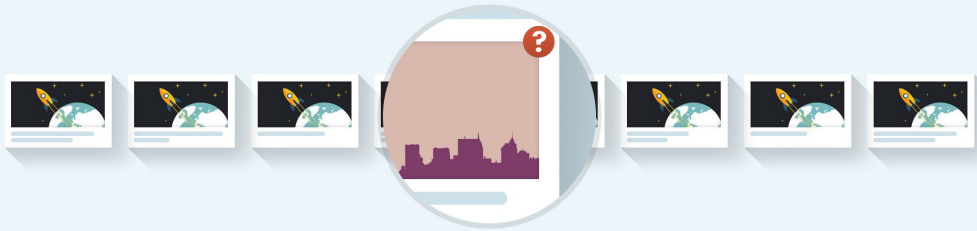

## MY PERFORMANCE

SHARE OF PROMOTED POSTS

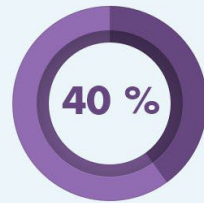

ORGANIC PROMOTED

BEST PERFORMING CONTENT

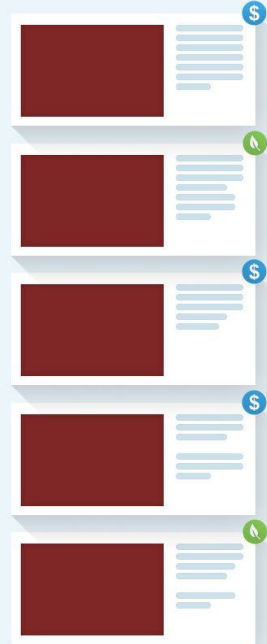

SHARE OF INTERACTIONS FROM PROMOTED POSTS

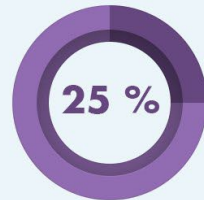

vs.

## MY COMPETITION

SHARE OF PROMOTED POSTS



ORGANIC PROMOTED

BEST PERFORMING CONTENT

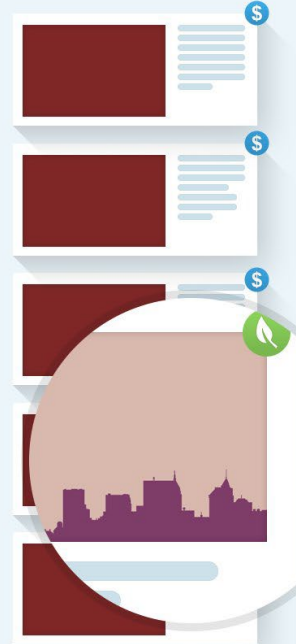

SHARE OF INTERACTIONS FROM PROMOTED POSTS





Dashboard Analytics Publisher + Add Profile ? [User]

### Create great social media content with Inspiration from the best

Track all of your conversations, monitor how well you are. Gain access to the largest social media content database so you can create great social content by being inspired by the best in a searchable library of over 10 billion Facebook, Instagram and Twitter posts.

Search: Fashion Week

- Favorite Posts: Favorite posts to easily find them later
- Data History: 10 billion Facebook, Instagram and Twitter posts
- Advanced Queries: Searchable by keyword and phrase
- Powerful Filters: Filter by industry and region

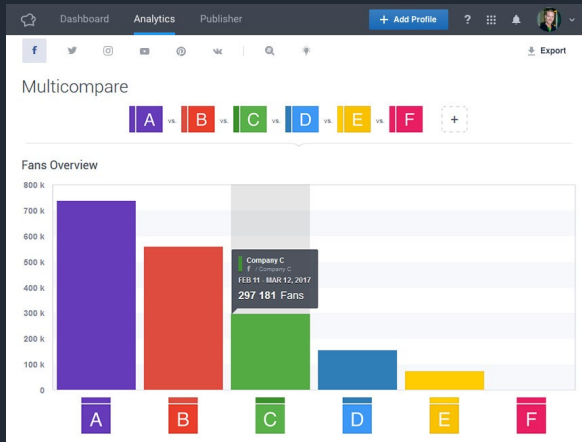

Dashboard Analytics Publisher + Add Profile ? [User]

### Inspiration

Search in Whole Database

flower Instagram Last 365 Days Search

Dashboard Analytics Publisher + Add Profile ? [User]

### New Export

- PDF
- PNG
- XLSX
- PPTX
- FULL PROFILE REPORT

I want to receive this export on a regular basis

I want to send this report via email

Send to: your.name@yourmail.com

Message Optional

Send and Download

Dashboard Analytics Publisher + Add Profile ? [User]

### Prime Time on Facebook

Schedule for the best time within the next 24 hours

Prime Time for the best day in the next 7 days

+1.5% 13:15 +12.3% Tue 14<sup>th</sup> MAR 2:23<sup>PM</sup> USE

How does it work?

Our unique Prime Time algorithm uncovers the best time to post, but also what increase in visibility you can expect at suggested times.

If you need to post the same day you're creating the post, you can use the suggestion for the selected day. The tool will also show you a different date and time for posting which can create better reach. Use that option if creating more reach is more important and the piece of content is not time-sensitive.

If you are scheduling one post for several pages, remember, each page has a different best time to post.

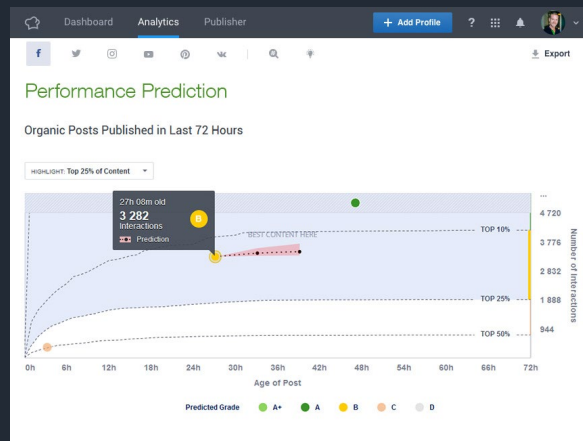

Dashboard Analytics Publisher + Add Profile ? [User]

### PrimeTime

Thursday 4:48 PM

Friday 4:12 PM 9.8%

Saturday 4:17 PM 0.5%

- Tailored publishing time recommendations for each Facebook page.
- Looks beyond audience activity and when they are online.
- See the best time to post on the day or best time and date over the next 7 days.

Dashboard Analytics Publisher + Add Profile ? [User]

### Promoted Post Detection

Understand your competition's organic/paid content mix with Promoted Post Detection.

Get unparalleled competitive insight into your competitor's paid content strategy so you can understand your competitive climate and respond accordingly.

- See how much content your competition are promoting
- Understand how well your competition's organic and paid content are performing
- Improve the efficiency of your paid strategy by tracking how well your organic/paid content mix is performing

Dashboard Analytics Publisher + Add Profile ? [User]

### Performance Prediction

Grading System	Min. of Interactions after 72 hours	Actionable content
A+	Better than any other post	5 710 0
A	Better than 90% of other posts	4 365 0
B	Better than 75% of other posts	2 245 0
C	Better than 50% of other posts	845 1
D	Worse than 50% of other posts	0 1

Actionable Content: > 2 organic posts in the past 3 days selected by PPD.

Goal Value

Last Month

+49.57 k% ↑

Relative Change

29.64 k Total

# SOCIALBAKERS PRODUCT PLATFORM

UI RE-DESIGN  
VISUAL DIRECTION  
UX CONSULTING

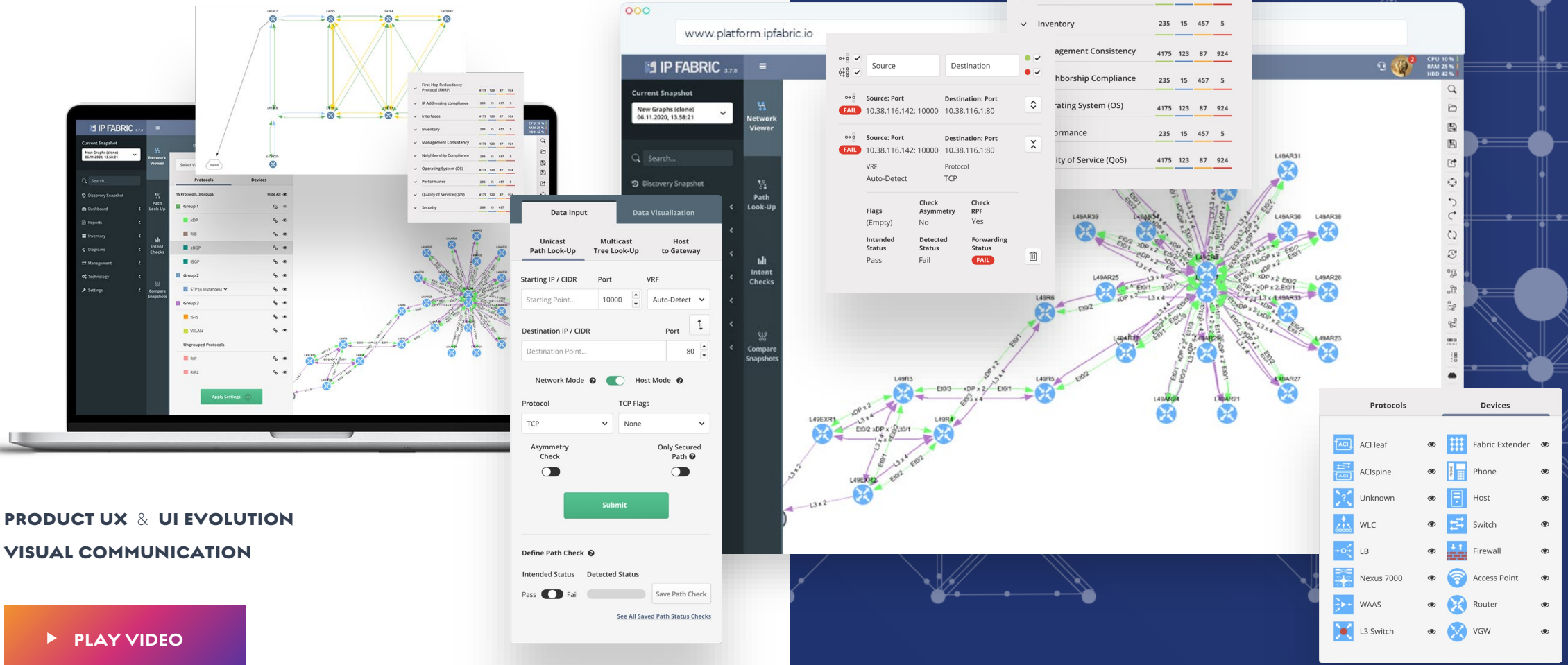

PRODUCT UX & UI EVOLUTION  
VISUAL COMMUNICATION

▶ PLAY VIDEO

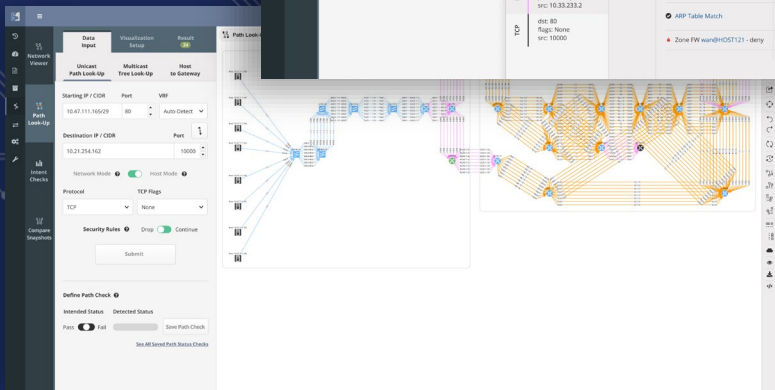
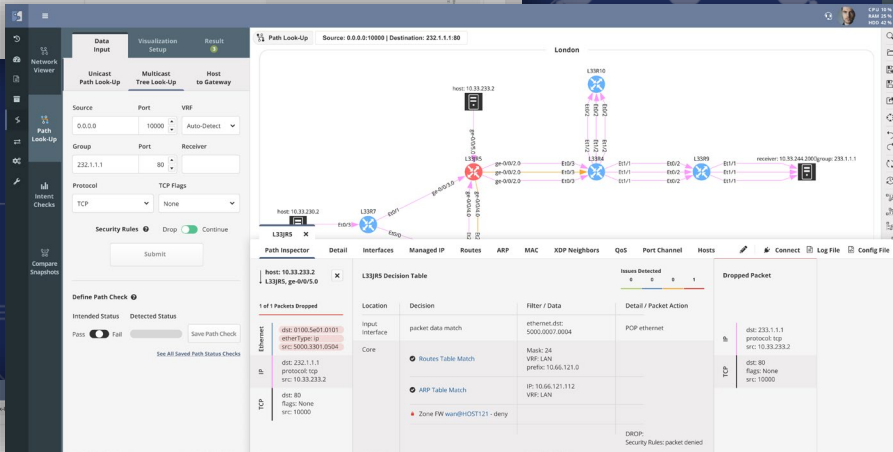
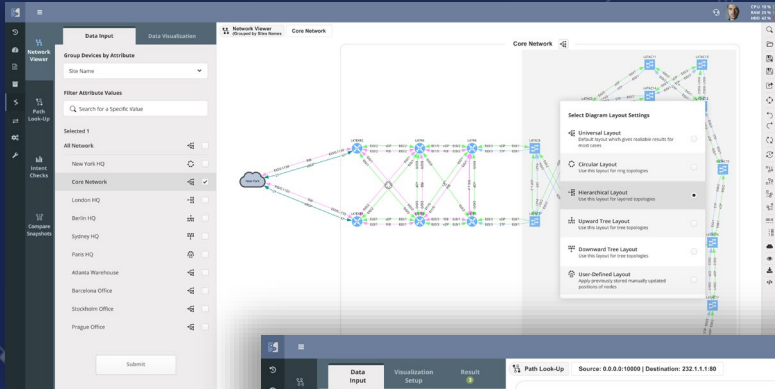

work  
wer

Path  
look-Up

Intent  
Checks

Data  
Input

Visualization  
Setup

Result  
24

Unicast  
Path Look-Up

Multicast  
Tree Look-Up

Host  
to Gateway

Starting IP / CIDR  
10.47.111.165/29

Port  
80

VRF  
Auto-Detect

Destination IP / CIDR  
10.21.254.162

Port  
10000

Network Mode  Host Mode

Protocol  
TCP

TCP Flags  
None

Security Rules  Drop Continue

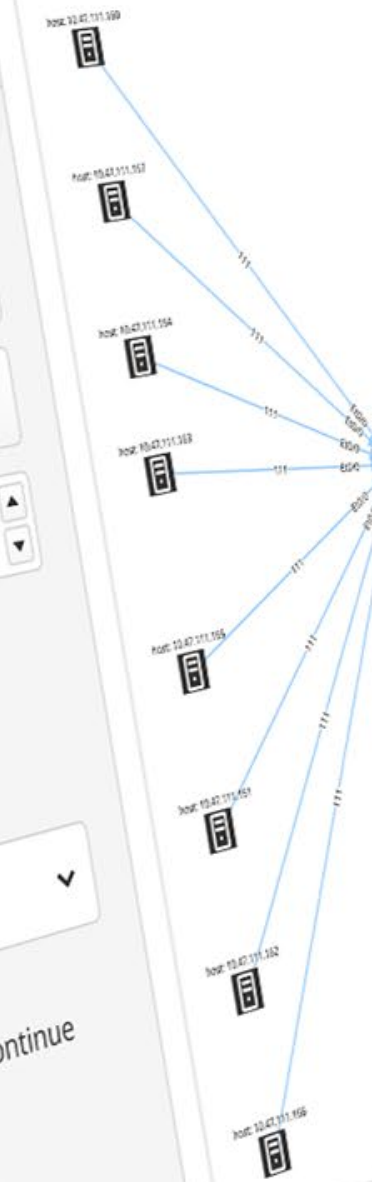

SOCIALBAKERS PLUS

Creative Webdesign,  
Illustration,  
Visual Storytelling

San Francisco New York London Prague Singapore Tokyo

socialbakers

100% SOCIALLY PROTECTED BY AGREEMENT

PRODUCT & DESIGN

SALES

SUPPORT

16

socialbakers

DEVELOPERS

Products Features

- 1) Competitive Analysis
- 2) Industry Benchmarking
- 3) Real-time Analytics
- 4) Industry Expert
- 5) Social Media
- 6) ...

DATA MINERS & TAGGERS

IT ADMINISTRATORS

HUMAN RESOURCES

socialbakers

FINANCE

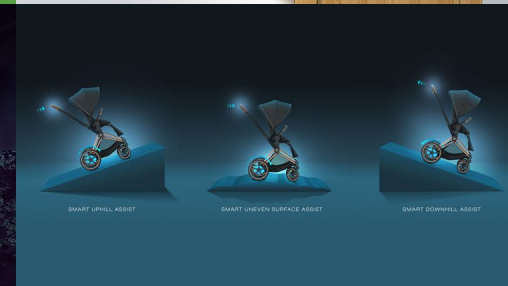
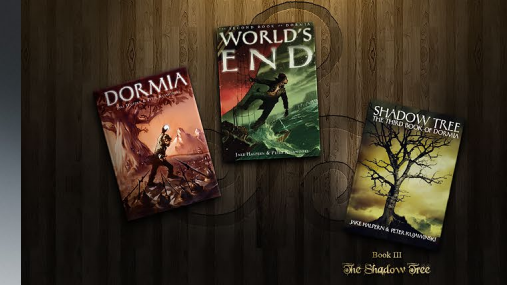

**SEO & INTERNET MARKETING**

Every day, millions will use search engines to find products or services. 90% of those people will click links on the first page of the search results. Is your site on that first page? Are your competitors?

**CUSTOM WEB DESIGN**  
Xplode Marketing is a Sarasota based Web Design Company focused on incredible websites at affordable prices.

**BRANDING & LOGO DESIGN**  
Stand out from your competition! Create a brand and identify your customers will never forget and your competition will envy.

**SEARCH ENGINE OPTIMIZATION**  
Sarasota Search Engine Optimization company gaining top results in all of the major search engines such as Google, Yahoo, & Bing

WEBSITE DESIGN | BRANDING & LOGO | SEO



**BrandLove**

Show Your Brand Love

Do you love Nike or Adidas more? Facebook or Coca-Cola or Pepsi? With Socializers' Facebook iOS Brand Love apps you can rate thousands of world's most renown brands, gain awesome exposure and compete with your friends!

Both our Facebook and iOS apps are designed to speed brands that you love and that matter. So what are you waiting for? Begin rating brands on iOS device now.

Available on the App Store | Facebook App

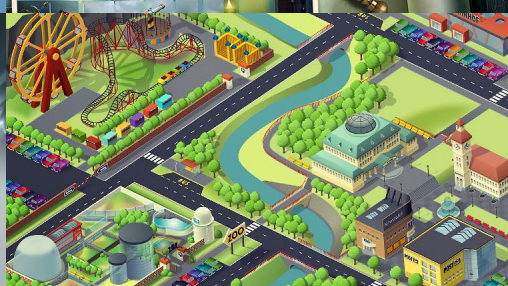



[WWW.POJETA.CZ](http://WWW.POJETA.CZ)

[TOMAS@POJETA.CZ](mailto:TOMAS@POJETA.CZ)

+420 607 983 211