

THE
LEE-
ENFIELD
RIFLE



Its history and development from
first designs to the present day—
fully illustrated

Major E.G.B. Reynolds

THE LEE-ENFIELD RIFLE

THE LEE-ENFIELD RIFLE

By

MAJOR E. G. B. REYNOLDS

LONDON: HERBERT JENKINS

*First published by
Herbert Jenkins Ltd
3 Duke of York Street
London, S.W.1
1960*

© E. G. B. REYNOLDS 1960

ALL RIGHTS RESERVED

Second Impression 1962

Printed in Great Britain by Cox and Wyman Limited, London, Reading and Fakenham

FOREWORD

BY LIEUT.-COLONEL LORD COTTESLOE, T.D., V.D.

THE introduction of firearms into the armies of this country goes back a long way. In 1590 Sir John Smythe, in a book that was promptly suppressed as contrary to public policy, was lamenting that the firearm had superseded the long bow, a far superior weapon, and even complaining that the firearms of that time were inferior to those of his youth. Sir Winston Churchill has written of Crecy that the arrow hail at 250 yards produced effects never reached again by infantry missiles at such a range until the American Civil War. It was not until after Waterloo that the rifle attained as great an effective range and accuracy as the long bow; nor was it until the introduction of the breech-loading rifle a hundred years ago that it could develop as high a rate of fire.

For some three hundred years, during which the cumbersome wheel lock and match lock were superseded by the flint lock and there was some development of rifled barrels and of cartridges to facilitate loading, the development of the firearm was slow. But early in the nineteenth century Alexander Forsyth's brilliant concept of the percussion cap led the way in a remarkable revolution that culminated during the latter half of the century in a breech-loading rifle with a small bore and with relatively shallow rifling to reduce the accumulation of powder fouling, a rifle firing a long bullet of high stability, capable of good accuracy and of a high rate of fire. These most important developments were followed by the bolt action and the magazine to feed into the chamber a number of cartridges, by great improvements in propellents that enabled the length of barrel to be reduced and the weapon to be easily handled, and by the pointed bullet that sustained its velocity up to long distances. These were developments that altogether revolutionized the value of the rifle as an instrument of war, and had a profound effect on military tactics.

All this came to its full flowering in the Lee-Enfield .303 magazine rifle, more particularly in the short model with which the British Army was equipped at the outbreak of the First World War in 1914. It was a rifle light and handy, accurate at short and at long ranges, and as a result of a providential chance in the curved design of the bolt lever capable of a remarkable rate of fire. With this rifle more than sixty shots were fired in a minute, as a *tour de force*, in the proof butts; and with the highest training and skill thirty-seven shots

could be fired at a target in the same time by a man in full Service equipment.

The Regular Army in 1914 were highly trained in the use of this rifle, and the impact of their rapid fire during the German invasion of France was so great that the Germans believed the British Army to be using machine-guns. The effect of the Lee-Enfield rifle, as used by an army trained in its application for rapid fire, was of the greatest importance and influence on the early course of the war.

The history of the development of the rifle during the nineteenth century, and its culmination, so far as this country was concerned, in the Lee-Enfield rifle, is little known to the public. Major Reynolds has done a valuable service in setting down, in a book that is a mine of interesting information, the factual history of this rifle and its development from the beginnings until the present day, and he is to be congratulated on assembling and making available this fascinating story.

mostly based on reports of the Small Arms Committees, who were the War Office authority on these matters. Some of the trials were inconclusive and the reports may appear disjointed at times but they are the facts as recorded in the official archives.

The author would like to emphasize the valuable assistance he has received from the Inspectorate of Armament's Pattern Room at the Royal Small Arms Factory, Enfield Lock. He remembers the wholesale slaughter of old records which took place soon after the War (while he was serving on the Headquarters Staff of the Inspectorate of Armaments) and is grateful to those Infantry Officers, and others, who did not regard Small Arms as so much "black magic", and saved what they could for future reference.

ACKNOWLEDGMENTS

THE author wishes to acknowledge with grateful thanks the assistance he received in the preparation of this book from Lieut.-Col. Lord Cottesloe, T.D., V.D., who wrote the Foreword; Brigadier C. A. R. Johnson and Major Michael Ward, M.B.E., D. of A. Branch Ministry of Supply; Lieut.-Col. O. A. Watts and Mr. Len Hobson, Inspectorate of Armaments; and Lieut.-Col. Burgh and Lieut.-Col. J. E. M. Hall, Australian Department of Supply.

The diagrams, or explanatory plates, in Chapters I, II, III and VI, are taken from the 1904 and 1909 editions of *The Text Book of Small Arms*, by kind permission of the Controller of Her Majesty's Stationery Office.

The diagrams in Chapters XII, XIII, XIV, XV, XVII and XIX are mostly from War Office and Ministry of Supply publications and are Crown Copyrights. Most of the illustrations were kindly provided by the Small Arms Division of D.I. Arm., and are Crown Copyright.

Dates of introduction to the service of weapons, and their descriptions, are mostly from War Office "List of Changes", and reports of trials and experiments are largely based on War Office Small Arms Committee Reports, all of which are Crown Copyright.

Diagrams in Chapter XVIII are from the Australian Department of Supply's official identification list.

Without the assistance of various departments of the above-mentioned administrations, especially the Pattern Room of the Inspectorate of Armaments, this book would not have been possible. The author takes this opportunity of expressing his gratitude to all concerned.

AUTHOR'S NOTE

THIS publication should be of particular interest to weapon collectors in all parts of the world, and to owners of any model of Lee-Enfield Rifle who want to know more about it. No collection of rifles can be complete without some representatives of the Lee-Enfield family, and this is a factual history of the Lee-Enfield from its inception to the present day.

Although its basic design remains unaltered during sixty years of service the Lee-Enfield has undergone many changes, according to the requirements from time to time of the British Services. The reasons for the changes, how and when they took place, are fully explained. All models and Marks of the Lee-Enfield are fully dealt with.

Throughout its many years of useful service the Lee-Enfield has had many critics, particularly regarding its accuracy as a target-shooting weapon. Many writers and critics appear to have overlooked the fact that it was designed as the British soldier's personal arm, and not as a target rifle. Its efficiency in the role for which it was intended was proved beyond question in the First World War and many survivors of those awful years of trench warfare will always regard the Short Lee-Enfield with no little affection. Its successor in World War II, the No. 4 Rifle, also proved itself a most efficient weapon of war and its smaller brother, the No. 5, emerged from the Far Eastern jungles with honours. The heavier barrel of the No. 4 has done much to enhance its reputation as an accurate target-shooting weapon. In many trials carried out during the Second World War the No. 4 Rifle, fitted with the No. 32 Telescope Sight, proved itself superior in accuracy to other sniping equipments, friendly and enemy, against which it was pitted.

Every effort has been made to avoid personal bias and opinions and compile an accurate factual history of the Lee-Enfield. Dates of introduction and official approval have all been taken from the War Office Lists of Changes. These dates are not necessarily those on which the various models first appeared in the British Services. For instance, the No. 4 Mark I* Rifle was being issued to the Forces in 1941, but its official introduction was delayed until 1946. This was an exception to the general rule and dates of approval and introduction were usually near the dates on which the weapons were first issued.

Accounts of trials which took place prior to World War II are

CONTENTS

	<i>page</i>
Foreword by Lieut.-Col. Lord Cottesloe, T.D., V.D.	5
I. Prelude to the First Lee-Enfield.	17
The first Enfield Rifle and the Pritchett bullet. A shortened rifle for the Navy, the last muzzle-loader. Muzzle-loading rifle problems. The first breech-loader, the Snider-Enfield. The Boxer cartridge. Introduction of Martini-Henry Rifle. The first solid cartridge case. Metford rifling. Magazine rifle development. Lee magazine and action successful in British trials. Progress in ballistics. France first with small-bore magazine rifle. Britain follows the Continental lead.	
II. The Parent of the Family: The Lee-Metford.	27
Description of the Lee-Metford Rifle, Mark I (formerly the Magazine Rifle, Mark I). Light lines used for sighting. The Mark I (Black-powder) cartridge—a temporary expedient. Development of Cordite and the first British smokeless rifle cartridge. The “pullthrough” supersedes the “Rod and jag” for barrel cleaning. Rifle becomes the Mark I*—a new sighting system is adopted and the safety-catch is omitted. The Mark II Rifle, a ten-round magazine and simplified bolt-head. The Mark II*, the safety-catch returns. A shortened weapon for the cavalry—the Mark I Carbine.	
III. The first Lee-Enfield.	37
The effect of cordite. Enfield rifling. Introduction of the Magazine Lee-Enfield Rifle, Mark I. Description of the rifle and how it functions.	
IV. Mostly Conversions, and troubles in South Africa.	48
Conversions to Enfield rifling. A new cartridge for range practice. Cavalry and Artillery Carbines. The Lee-Metford on the North-West Frontier. The Dum-Dum bullet. A new Service cartridge, the Mark V. Mineral jelly replaces rifle oil. Effective marksmanship of the Boers. An appeal from Lord Roberts. Reports and complaints from South Africa. Much long distance shooting. Long range trial at Aldershot.	
V. Accomplishments of new Small Arms Committee.	61
A new constitution for the Small Arms Committee. Emergency sighting correction for South Africa. Important discoveries. An accuracy shooting test is instituted. Methods used in other countries for accuracy testing. Suggested new rifle for the British Forces. Adoption of the 100-ft. testing range. Interest in the Cei Gas Rifle.	
VI. A shortened Rifle for Cavalry and Infantry.	71
Trials with shortened Lee-Enfield Rifles. Approval for the manufacture of a thousand for troop trials. Nomenclature changes. How loose butts were dealt with. Determining barrel accuracy life by gauging. “Travelling View.”	

- VII. The trial of the thousand rifles and adoption of the Short Magazine Lee-Enfield. 78
 The trial programme. The Royal Navy, Royal Marines, the Cavalry and Infantry all try out the new weapon. Short Rifle gets good reception from the British Services and is adopted. Description of the new rifle and method of stocking-up.
- VIII. Mostly trials and experiments. 90
 Report on Short Rifle from Somaliland. Investigation into cause of "wild" shots. Effect of oiled bullets and barrel. Sighting limit of dial sight—long distance trials at Lydd. Examination of thousand rifles after troop trials. Introduction of S.M.L.E. Converted Mark II Rifle. A new cartridge for the British Services. Cordite M.D.T. approved for future use.
- IX. Lord Kitchener Reports. 100
 Lord Kitchener's report from India. Comparative trials with Long and Short Rifles. The Short Rifle Mark I* and the Converted Mark II*.
- X. The Mark III S.M.L.E. and Mark VII Cartridge are introduced; and proved in battle. 108
 The S.M.L.E. Rifle, Mark III, is introduced. A new system for loading by charger. More conversions. An aperture sight for target shooting. The Mark VII Cartridge; a new bullet for the British Services. Easements for war-time manufacture. The cut-off goes, and the Mark III* rifle is the result. The "Bantam" butt for the short soldier. The "E.Y." Rifle is approved for grenade firing. The S.M.L.E. is proved a first class weapon of war.
- XI. The Pattern 1914 Enfield Rifle. 123
 The .276-in. Experimental Rifle and Cartridge. Trial by troops. Troubles with the new cartridge. New weapon nearing adoption by the British Service. Plans changed by the 1914-18 War. A rifle for the sniper.
- XII. A new Rifle, and a new type of bayonet. 129
 Changed ideas for new British Rifle. Influence of war. Pattern sealed for manufacture of Mark V Rifle. Unpopular at Bisley try-out. The Mark V abandoned. First developments of the Mark VI. A new design of bayonet; a "spike" instead of a "blade" is developed and tested. Successful in trials. The question of "compensation"; inconclusive trials.
- XIII. Development and Introduction of the No. 4 Rifle. 141
 Prototypes of the Mark VI Rifle. Technical and Service trials. Effect of the bayonet. Investigations into effect of barrel vibrations. Troop trials with the new rifle. It becomes the No. 4 Rifle and is approved for the British Service.

XIV. The No. 4 Mark I* Rifle, and Problems of War-time manufacture.	152
The No. 4 Mark I* Rifle. Canadian and U.S. Production. Three new U.K. rifle factories for the needs of war. Dearth of unskilled labour for making rifles. Alternative forms of manufacture. Fabrication and welding helps production. Serious shortage of rifle furniture. Problem not solved by "all-metal" weapons, or plastics.	
XV. Weapons for the Jungle and the Sniper.	164
Requirement for jungle fighting. A lighter weapon is developed. The No. 5 Rifle, Mark I, is adopted by the British Army. A new telescopic equipment for the British Sniper, the Rifle No. 4, Mark I (T).	
XVI. Manufacture and Factory History.	173
Outline of manufacture of an Enfield Rifle. Accuracy standards, and testing for accuracy. Proof test. Marks of identification. Development of rifle manufacture at Enfield and Birmingham.	
XVII. Mostly Post-war developments.	182
A stabilized pull-off for the Lee-Enfield. Introduction of the No. 4 Rifle, Mark II. Furniture troubles, and a new form of stocking-up is adopted by the National Rifle Association. A solution of breeching-up problems. Enfield Rifles and Bisley. New lease of life as a "Sporter".	
XVIII. The Australian Story.	188
The first Australian rifle factory. The Australian Imperial Forces adopt the Short Magazine Lee-Enfield Rifle, and the Commonwealth proceeds to make it. Lithgow factory expands rapidly for war-time manufacture. Generous gesture following Dunkirk. The heavy-barrelled S.M.L.E. Lithgow develops lightened rifles for jungle fighting. The S.M.L.E. as a semi-automatic.	
XIX. The Lee-Enfield in the .22-in. role.	197
Early aiming-tube adapters in the British Army. Introduction of the Rim-fire cartridge. Solid .22-in. barrels replace aiming tubes. Conversions of Service rifles. Aiming-tubes become obsolescent. Tubed barrels to meet 1914-18 War requirements. Conveyor system short-lived. A target shooting .22-in. rifle for the British Forces. Development of the No. 8 Rifle. The Royal Air Force have the No. 7, and the Royal Navy the No. 9 Rifle.	
Appendices	208
Index	219

LIST OF ILLUSTRATIONS

Between pages 24 and 25

Four Early British Service Weapons	
Improved Lee Magazine Rifle; Lee-Burton Magazine Rifle; Owen Jones Magazine Rifle	
The Martini-Henrys	
The First Enfield Rifle	
	<i>Facing Page</i>
The Snider Cavalry Carbine; The Martini-Enfield Carbine; The Lee-Enfield Carbine	31
The Lee-Metford Rifle; The Lee-Enfield Rifle	32
The Mauser Rifle	48
The Lee-Metford Carbine; The Lee-Metford Rifle	49
A German 7.92 Service Rifle	64
The No. 1, Mark V Rifle	64
The Short Magazine Lee-Enfield Rifle 303 No. 1, Mark III; The Pattern 1914 Enfield Rifle; The No. 4 Rifle, Mark I	65
Martinis and Lee-Enfields	80
The S.M.L.E. with Bayonet Fixed	81
The S.M.L.E. with Grenade Discharger	81
The First Tangent Leaf Backsight to be Approved for the British Army	96
The 7.92 mm. German Infantry Self-Loading Rifle	97
No. 4 Rifle Action (Fired Position)	112
No. 4 Rifle Action (Cocked Position)	112
Rifles and Bayonets of Two World Wars	113

Between pages 120 and 121

The No. 5 Rifle, Mark I	
British Service Rifle Cartridges 1867-1958	
British Snipers' Rifles in Two World Wars	
The No. 5 Rifle, Mark I	
	<i>Facing Page</i>
The No. 1 Rifle, Mark VI	128
The No. 4 Rifle, Mark I	129
German 7.92 mm. F.G. 42 Automatic Rifle	144
The De Lisle Carbine	144
British Bayonets	145
The Telescopic Layer	160

The Enfield Rest	161
G. E. Fulton, Winner of the Queen's Prize, 1888	176
Mr. A. G. Fulton, D.C.M. and Major Robin Fulton	176
Trigger Tester for Lee-Enfield Rifles	177
<i>Between pages 184 and 185</i>	
Three Rifles produced at Lithgow (Australia)	
The Australian No. 1 Rifle Skeletonized	
Directorate of Inspection of Armaments Pattern Room at R.S.A.F. Enfield Lock	
The No. 8 .22-in. Rifle: Infantry Model	
The No. 8 .22-in. Rifle: Match Model	

CHAPTER I

PRELUDE TO THE FIRST LEE-ENFIELD

THE Royal Small Arms Factory at Enfield Lock, Middlesex, or the Royal Manufactory of Small Arms as it was known in its early days, has for many years been the traditional home of the British Service rifle. Here, in 1852, the first official Army rifle to bear the name "Enfield" was manufactured. This was a muzzle-loading rifle weighing nearly nine pounds and it remained the British Service arm for several years, seeing useful service during the latter part of the Crimean campaign.

When the Enfield rifle came into being the system of rifled barrels was well established but not perfected, and still presented problems to the designers. Principal among these was one of loading. Whilst it had been an easy matter to force a lead ball down the smooth bore of a muzzle-loading weapon, it was found to be a much more difficult task to do the same thing with a rifled barrel and not distort the bullet. With the Enfield rifle this problem was largely solved by the introduction of the Pritchett bullet. The Pritchett bullet was of .568-in. diameter and the bore diameter of the weapon was .577 in. It would therefore pass easily down the barrel during loading, but expanded to a tight fit on detonation. This expansion was achieved by giving the bullet a hollow base. When the charge was fired the bullet instantly expanded to fill the grooves of the rifling, forming a seal against the following gases and giving the bullet stability in flight. In later models, the cavity in the base of the bullet was fitted with a wooden plug to give even greater expansion, and the diameter was reduced to .55 in.

In 1858 a shortened version of the Enfield rifle was produced for the Navy and was also issued to certain rifle regiments. The rifling of this weapon differed from the original in that it had five grooves instead of three, with a twist of one complete turn in four feet. This shortened version, which was said to give greater accuracy, had the distinction of being the last of the muzzle-loaders to be adopted by the British Military authorities.

With the principle of the rifled barrel universally established,

inventors and weapon designers concentrated their attention on perfecting a method of loading at the breech end. However, the problem of preventing the escape of gas through the joints of the action, and of dealing with the accumulation of deposit left by the charge when fired, had no easy solution. In 1864 a Committee was set up by British Military authorities to investigate and report on the practicability of introducing a breech-loading rifle in the British Army. There was some opposition to this innovation, based principally on the fear that, owing to ease and rapidity of loading at the breech, men might not use their ammunition to the best advantage and, in the excitement of battle, might discharge it all at an approaching enemy before reaching an effective range. The Committee, however, were not long in coming to a favourable decision, and as a consequence, gunsmiths and manufacturers were invited to submit suggestions for mechanisms which would enable the muzzle-loading Enfields to be converted to breech-loading.

After exhaustive trials at Woolwich Arsenal, during which some fifty different breech-loading systems were under close examination, the system submitted by Jacob Snider, an American, was adopted in 1867. The Snider action, which could be fitted without difficulty to the existing Enfield rifles, embodied a breech block hinged on the right side of the rear of the barrel which, when opened, gave access to the chamber. When closed it was held in position by a spring catch stud. A striker passed diagonally through the block, its rear end exposed to the blow of the hammer; its forward end lying adjacent to the percussion cap of the cartridge (Fig. 1). Primary extraction of the empty cartridge case was effected by means of a claw extractor attached to the front of the breech block. After the breech block had been opened it could be drawn back a short distance. By this movement the empty case was withdrawn from the chamber and it was afterwards ejected by turning the rifle over.

A suitable cartridge for the new breech-loader was being considered at the same time as the rifle. Cartridges in use in existing breech-loading systems had varying forms of paper cases which were not proving very satisfactory; ineffective gas sealing being their principal weakness. In 1866 an entirely new design of cartridge was introduced by Colonel Boxer. It marked a great advance in cartridge development and may be regarded as the basis of modern cartridge construction. The case was constructed of thin sheet brass, rolled round to a double thickness and overlap. This, together with a brass chamber for anvil and cap, was fixed to an iron base. The case was given a lining of shellac and thin white paper to prevent corrosion caused by the contact of powder on metal, and cemented on the outside was a covering of paper. When fired, the case unrolled slightly under pressure of the explosion—effectively sealing the chamber—and slight contraction on release of gas pressure per-

filled by a wooden plug and in others the cavity was concealed by spinning over the lead. The cartridge was later fitted with an improved form of anvil and, after further improvements had been effected, it was officially adopted for the Snider Rifle.

The official name of the new arm was the SNIDER-ENFIELD rifle and it had the distinction of being the first breech-loading rifle to be adopted by the British Army. When its ammunition had been perfected, its accuracy was superior to that of the muzzle-loading Enfields.

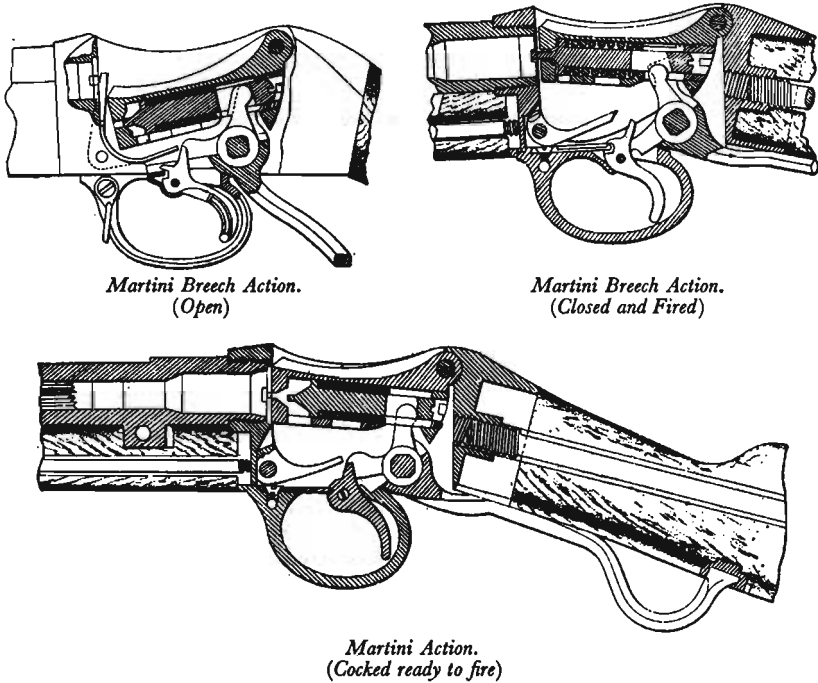

FIG. 2. Martini action in three positions.

The conversion of the muzzle-loading Enfields to breech-loaders was, however, only a temporary expedient. Experiments had shown the advantages of a smaller calibre weapon in reducing the weight of cartridges and in increasing velocity and flatness of trajectory.

In 1867 a new Committee was formed to enquire further into this, and eventually a weapon embodying a breech action invented by M. Frederick Von Martini of Switzerland and a barrel designed by Mr. Alexander Henry of Edinburgh was recommended for Service trials.

The action of this rifle was of the under-level falling-block type (Fig. 2). The barrel was 33.2 in. in length with a bore diameter of

mitted easy extraction of the empty case. The bullet was made of pure lead and weighed 480 grains. It was just over an inch in length and had a diameter of $\cdot 573$ in. The propellent charge was 70 grains of black powder. To assist the bullet to expand and take the rifling,

SNIDER.

1866.

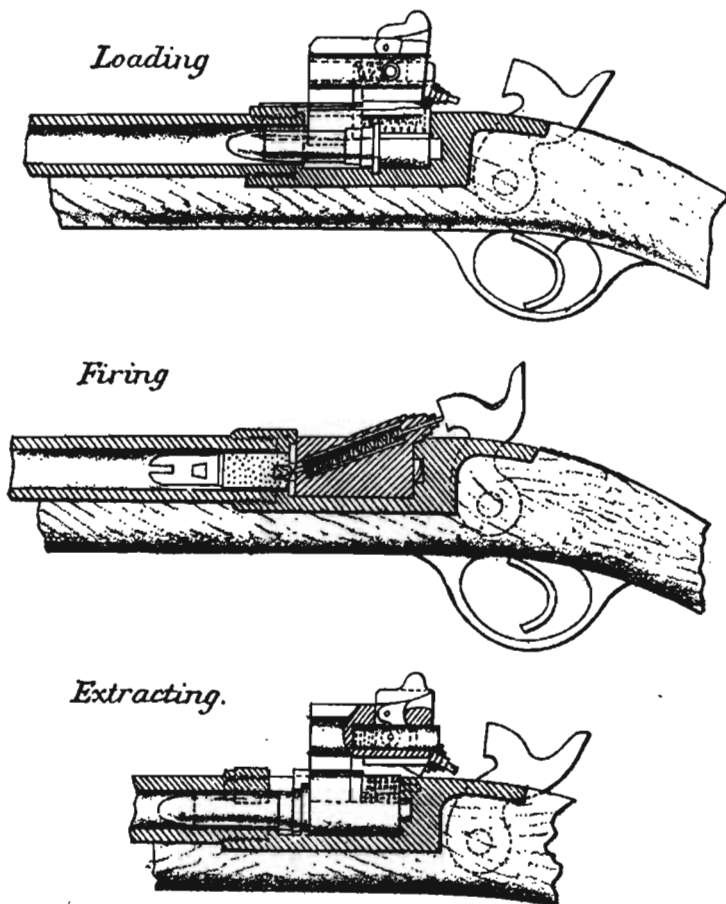

FIG. 1. *The Snider action in three positions.*

it had a cavity in the base into which was fitted a wood plug (later compressed clay was used for this purpose). In order to give it greater length in proportion to its diameter without adding to its weight, it had a cavity in its conical end. In some instances this was

.45 in. The rifling was seven-grooved with a uniform spiral of one right-handed turn in 22 in., the grooves being .009 in. deep at the breech end and .007 in. deep at the muzzle. The width of the lands between the grooves was .003 in. The weight of the rifle was 8 lb. 10½ oz. and the overall length 4 ft. 1½ in. It was officially adopted by the British authorities in April 1871 and named the MARTINI-HENRY rifle.

Despite many experiments, it was some years before a lighter bullet than that used in the Snider rifle could be found for the Martini-Henry. The selected cartridge for the Martini-Henry, as for the Snider, had a bullet weighing 480 grains and a case made of rolled sheet brass. It differed from the Boxer cartridge in shape, being bottle-shaped to fit the enlarger chamber. The diameter of the bullet was .45 in. and the charge was 85 grains of black powder. Eventually an improved cartridge was evolved which had a case of solid drawn brass. It had a calibre of .402 in., a lead bullet of 380 grains, and a charge of 85 grains of black powder. It marked the end of the era of the wrapped-brass case.

In 1883 a new Small Arms Committee was formed, and one of its purposes was to consider the possibility of improving the Martini-Henry. Three years later it recommended a reduction in calibre to .402 in. and the adoption of the improved cartridge already referred to. The reduced calibre was coupled with a change in rifling, and at first it was decided to adopt a form known as ratchet grooving. In this the groove, instead of being symmetrical, was deeper at one side than the other. The first sealed patterns to govern manufacture were made up embodying this form of rifling but the decision was changed, and the type which was eventually recommended was one which had been developed a few years earlier by Mr. Metford, a Civil Engineer of high repute as a weapon designer. This was seven-grooved, and had met with conspicuous success in competition target shooting. The grooves were shallow, without sharp angles, and therefore less susceptible to fouling.

The recommendations were adopted and, in 1886, 70,000 rifles embodying the new design of barrel were manufactured at Enfield and named ENFIELD-MARTINI rifles. Due to pending changes they were never officially introduced into the Service. The records show that they were afterwards made into a Mark IV Pattern of the Martini-Henry, with a calibre of .45 in.

During the last quarter of the nineteenth century the trend in rifle design was definitely towards speed in loading, effectiveness at longer ranges, and smaller calibre cartridges of greater power. Important developments in the science of ballistics, especially in the field of smokeless propellents, had widened the scope for future progress. Considerable advance had also taken place in the development of rifles carrying a reserve of cartridges which could be quickly

loaded successively into the chamber. These were called magazine rifles and they usually embodied a metal receptacle positioned under, or at the side, of the body to hold the cartridges, from which they were fed into the chamber by the forward movement of the bolt. The Great Powers were all taking an increasing interest in this development and some countries already had systems in use.

The Small Arms Committee formed in 1883 to deal with the Martini-Henry, were also instructed to report on the following:

- (a) As to the desirability or otherwise of introducing a magazine rifle for naval or military use, or both.
- (b) As to the best pattern of such arm, should the Committee decide to recommend one for adoption.

The Committee's first job was to send out a series of questions to experienced officers in the Services, and their answers produced a concurrence of opinion on the following points:

- (1) That a magazine arm, when used as a single loader, should not be inferior to the Martini-Henry.
- (2) That the magazine should contain at least five rounds.
- (3) That the weight of the arm should not be excessive.
- (4) That the mechanism should not be very complicated.

The Admiralty expressed a strong opinion that a magazine rifle was necessary for the Navy and pressed for its early adoption. Some of the replies received are worth recording as they give a fair picture of the general reaction to this new departure in military weapons. The following are extracted quotations: "All the experiments that are now going on in France and Germany, and in both countries they are working very hard at the subject, lead me to believe that they doubt finding an attachable magazine that will answer the necessary requirements, and they are now beginning to consider it essential that the magazine should be in the rifle itself; the cases in which it will be possible to use the magazine with effect will produce themselves so seldom that, if it were not for the moral effect that the gun will give to the soldier, I should not consider that much money ought to be spent over the affair. But this moral effect will be enormous; in fact, nearly as great as that shown in 1886, when breech-loaders were pitted against muzzle-loaders. This is undoubtedly the idea here, and they have a nervous dread lest the Germans should find a serviceable magazine rifle before them. In the French Army they do not appear to think very highly of the idea of a magazine rifle *per se*, but they say that their troops would never stand up to an enemy armed on the newer system if they still retained the old"; "Twenty years ago, when the much-vexed question of breech-loaders versus muzzle-loaders was being hotly discussed in this country, the Prussian army had for fully twenty years

been armed with breech-loaders; with these they had, in 1848, successfully fought the revolutionists at Dresden and Radstadd. Yet it was not until after the collapse of the muzzle-loading Austrian army at Sadowa, in 1866, that the opposition to the adoption of a breech-loading rifle into our service was abandoned, all the current objections, such as 'waste of ammunition', 'impossibility of controlling fire', 'impossibility of keeping up supplies in the field', 'liability of the mechanism to get out of order', 'difficulty of repairs on service', etc., all disappeared before such a crushing argument as the Prussian breech-loading fire, as exemplified in the Austria-Prussian campaigns, and our own experience has since proved the fallacy of the objections, at that time so strongly urged against breech-loading arms. So also, I am convinced, it will be with the repeater"; "All the Powers of Europe are watching one another on this question . . . we should make haste to introduce a magazine rifle, the cost affects us less than other nations; it is our game to force them on and keep ahead ourselves". One prominent officer of the day to whom the questionnaire was sent was definitely opposed to the introduction of a magazine rifle, and expressed his opinion in no uncertain terms as follows: "I have no suggestions to make in favour of the magazine gun for Infantry. The Germans are trying the Mauser system; they have issued 2,000 rifles to four battalions in different parts of the country, Konizsberg, Dantzic, somewhere on the Rhine, Coblenz and Spandau. This is to avoid what otherwise might take place were they all tried in the same garrison, Commanding Officers giving all a similar opinion more or less previously arranged; secondly, each trial is conducted under a different district commander; and lastly, the men to whom they are issued for trial belong to four totally different classes of physique of the German people. The reports will not be made until the Autumn. As far as I can learn the Germans are not in favour of any magazine arm, and the Mauser is not a very good system. The Germans will not be the first to adopt it, and, I think, even doubtful whether the adoption of such an arm by France or Russia would force them into it. The Germans, as a whole, are very fair shots, and if they had the Chassepot in the last war instead of the miserable weapon they carried, not a Frenchman would have escaped to tell the tale. Our Martini-Henry rifle is the best arm of its kind. Our men require more frequent practice and very careful training, but they require NO MAGAZINE RIFLE." (The Chassepot was the rifle with which the French were armed in the Franco-Prussian War. It had a bolt carrying a needle-striker; the charge being fired by a percussion cap placed at the base of the cartridge. The bore was .434 in.; the bullet was larger, being .463-in. diameter, 1 in. in length and weighed 380 grains.)

A large number of weapons, including Continental and American

designs, were examined and submitted to trials. Only three did not break down in any of the tests; they were:

- (1) The Lee Magazine rifle, as improved at the Royal Small Arms Factory at Enfield.
- (2) The Improved Lee Rifle, with Bethel Burton magazine modified at Enfield.
- (3) The Owen Jones Magazine Rifle, manufactured at Enfield.

These three were submitted to further trials and the first to be recommended for adoption was the Owen Jones. Eventually the Lee rifles were further improved and the Owen Jones, which was not so simple or cheap to manufacture or repair, was discarded. Final trials took place with the Lee Magazine Rifle and the Lee Rifle with Bethel Burton magazine in 1887. The rifles were now fitted with .402-in. barrels embodying the Metford type of rifling, in the former trials they had Martini-Henry barrels of .45-in. calibre.

The Lee Magazine Rifle weighed 9 lb. 6 oz. with empty magazine. The magazine was a development of one which was produced in 1879 by an American, James P. Lee of Ilion, New York. It was a box magazine, positioned and working on much the same principle as the magazines of today, and consisted of a metal case which fitted into the body of the rifle from below, immediately in front of the trigger-guard. It had capacity for five cartridges, inserted by hand from the top. The cartridges lay horizontally against the upward thrust of a spring in the bottom of the magazine. The top cartridge was retained in position under small flanges projecting inwardly from the top of the side walls of the magazine and was fed into the chamber by the forward movement of the bolt. The magazine was made deeper at the rear than in front to ensure correct positioning of each cartridge. It was secured in position in the rifle by a spring catch and was easily detached.

The Bethel Burton magazine was a hopper placed on the right of the action and was also constructed to hold five cartridges. When not in use it lay alongside the action, the top projecting about an inch above it. In this position cartridges could not be fed into the chamber. When required for use the magazine was pushed inwards until the top projected about two inches above the body of the rifle, and in this position the cartridges could be fed on to an elevator. In action, the elevator raised the cartridges in front of the bolt face and they were fed into the chamber by the forward movement of the bolt.

The final trial result was greatly in favour of the Lee Magazine Rifle; the magazine placed underneath the action was considered to be better than the Bethel Burton system. The bolt action of the latter was also considered inferior. No decision could yet be made



1

2

3

4

FOUR EARLY BRITISH SERVICE WEAPONS

(1) The well-known **BROWN BESS** as used at the **Battle of Waterloo**. It had fair accuracy up to 200 yards. (2) An early example embodying the percussion system of ignition. (3) The first **ENFIELD** (described in Chapter I). (4) The first British Service breech-loading rifle.

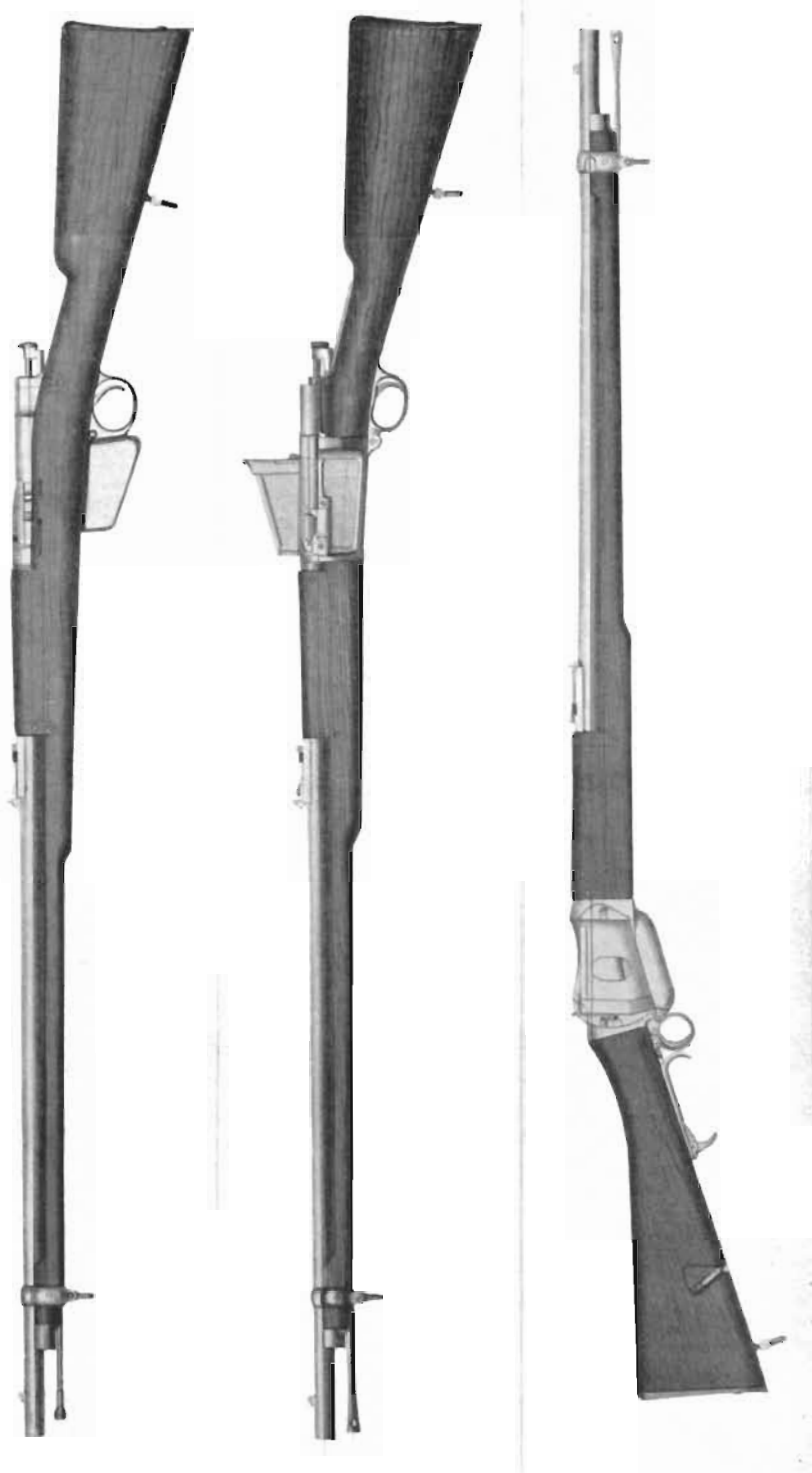

Top: IMPROVED LEE MAGAZINE RIFLE. Centre: LEE-BURTON MAGAZINE RIFLE. Bottom: OWEN JONES MAGAZINE RIFLE

The three survivors of the early trials which led to the adoption of a magazine rifle for the British Army.



THE MARTINI-HENRYS

Top: THE MARTINI-HENRY CARBINE. *Bottom:* THE MARTINI-HENRY RIFLE

The Martini-Henry Rifle was adopted for the British Services in 1871. This illustration shows the considerable difference in length between the Rifle and the Carbine which became the personal arm of Gunners and Cavalrymen. A number of these weapons, fitted with .303-in. barrels were still in use for Home Service during the 1914-18 war. The Martini-Henry Rifle, fitted with a .22-in. barrel, was an extremely accurate target rifle and played a big part towards popularizing the .22-in. target shooting movement in the U.K. at the beginning of the century.



"Rifle Muzzle-Loading Enfield 577" PATTERN 1853.



"Rifle Muzzle-Loading Enfield 577" PATTERN 1853.

THE FIRST ENFIELD RIFLE

The first British Service Rifle to bear the name ENFIELD. It played a successful part in battle during the latter part of the Crimean campaign. A shorter version for the Navy, and also issued to certain rifle regiments, was known as the SEA SERVICE RIFLE and was the last of the British Service muzzle-loaders.

as the question of a smaller calibre rifle had been reopened, following successful developments in this direction on the Continent.

Although smokeless powders had been in existence for several years as efficient propellant charges for sporting gun cartridges, their action was too swift for use in rifled weapons. In 1886 the first smokeless powder suitable for rifles came into use. This was an invention of a young French chemist, M. Vieille, and was named "Poudre B" after General Boulanger, the French Minister for War. It gave higher velocities and lower pressures than black powder, and the French lost no time in profiting by it. As a consequence, the Lebel rifle was introduced into the French Army later in the year. This, the first of the small bore military magazine rifles—.315-in. calibre—was fed from a magazine which consisted of a longitudinal hole, partly steel lined, bored in the stock fore-end and which had capacity for eight of the new smokeless powder cartridges.

Meanwhile an important advance in quicker loading was becoming established on the Continent. This was a system of multiple loading, effected by means of a steel clip which held five cartridges. These were pressed into the open magazine from the top and when all had been expended the clip fell clear through an opening in the bottom of the magazine. This was an important step towards lessening the loading time factor and, in 1886, it was incorporated with a .433-in. Mannlicher magazine rifle adopted by Austria. This was the first military rifle fitted with the Lee magazine to be adopted by any European nation. Two years later this rifle was converted to .315-in. bore. When Germany adopted the principle of clip loading in 1888 in association with a new Mannlicher rifle of .311-in. bore, the weapon put her ahead of all her rivals. She now had at her command the first small bore service rifle incorporating multiple loading and firing smokeless cartridges.

It was an innovation that created widespread interest and, during large-scale manoeuvres of the German Army in Thuringia, the British War Office sent an observer who paid considerable attention to the functioning of this rifle in the field. Despite accusations levelled at this weapon—including a prevalence of accidents and the jamming of cartridges when being fed into the chamber—the observer could find no evidence to substantiate them. Occasionally a cartridge would get awry as the bolt was pushed home and the round would get jammed in the bolt-way, but these were infrequent occurrences which could be quickly corrected and caused only momentary loss of time. There was no doubt that the German soldiers had every confidence in their new weapon which they firmly believed to be superior to that of the French, and in holding this view they were undoubtedly right.

The action now taken by the British Small Arms Committee, influenced by the trend of events on the Continent and the results

of trials they had carried out with small calibre weapons, was to recommend a .303-in. calibre rifle for the British services and, early in 1888, a new weapon embodying the improved Lee action and magazine and Metford rifling was approved for troop trials. About 350 rifles were issued to troops throughout the British Empire and the cartridges which were used in them were loaded with a compressed pellet of black powder.

CHAPTER II

THE PARENT OF THE FAMILY: THE LEE-METFORD

REPORTS on the troop trials carried out in the Summer of 1888 showed the new magazine rifle to be a satisfactory weapon and it was officially approved for manufacture on 22nd December of that year. It was called the **MAGAZINE RIFLE MARK I**, and the following description appeared in the List of Changes in War Material issued with British Army Orders dated 1st December, 1889:

“Weight of rifle	9 lb. 8 oz.
” ” sword bayonet	15½ oz.
” ” ” ” scabbard	4½ oz.
” ” magazine (empty)	4¾ oz.
” ” ” (filled)	13 oz.
Length of rifle	4 ft. 1·5 in.
” ” ” with sword bayonet	5 ft. 1·45 in.
” ” sword bayonet	1 ft. 4·68 in.

Barrel and rifling.

Length of barrel	30·2 in.
Calibre	·303 in.
Rifling	Metford segmental
Grooves, number	Seven
” depth	·004 in.
Width of lands	·023 in.
Spiral, left-handed	1 turn in 10 in., or 33 calibres

The rifle embodies the Lee bolt action, with rear locking. The cocking-piece is so arranged that the action can be set at half-cock, in which position the rifle can be carried in safety. Covers are fitted to the bolt and bolt-head to protect the action in sand and mud. A safety-catch is fitted on the left side of the body, the pulling back of which, when the rifle is at full-cock, prevents any effect being caused by pressing the trigger. When springs are ‘eased’, and the cocking-piece is in the forward position, it locks the action and

prevents the bolt from becoming accidentally opened. *The magazine* consists of a sheet-steel box, inserted in the body through an opening underneath, and directly in front of, the trigger-guard. It is held in position by a spring in the body engaging in a notch on the magazine. It holds eight cartridges and can be filled when in position on the rifle, or when detached, by inserting the cartridges singly. A spring at the bottom of the magazine presses upwards a movable platform, on which lies the column of cartridges. These are in turn forced into position in the bolt-way, from which they are fed into the chamber by the forward movement of the bolt. A cut-off is fitted to the right side of the body which, when pressed inwards, stops the supply of cartridges from the magazine, thus enabling the weapon to be used as a single-loader. When the cut-off is pulled out, the lower edge of the face of the bolt-head, on the bolt being driven forwards, engages the top edge of the uppermost cartridge in the magazine and forces it into the chamber. The magazine can be removed from the rifle by pressing a small lever inside the trigger-guard. One magazine is attached, by means of a chain link, to each rifle; a spare magazine is also issued with each arm.

The stock, like that of the Martini-Henry rifle, is in two pieces, the fore-end and the butt. Under the rear part of the small of the butt is a projection, forming a so-called 'pistol grip'.

The butt is secured to the body of the rifle by a stock bolt. The butt-plate on the rear of the butt is fitted with a trap, giving access to the unoccupied portion of the stock bolt recess, which is arranged to house an oil bottle and a jag (a cleaning implement which screws on to the cleaning-rod, and on which is wound a piece of flannelette when the bore of the barrel is being cleaned).

All rifles of this pattern have the same length of butt, instead of two lengths as with previous rifles. The butt is $\frac{3}{8}$ in. shorter than the 'short' butt for the Martini-Henry rifle.

The nose-cap is fitted with a bar on top for the attachment of the sword bayonet, which is positioned underneath the barrel.

The cleaning-rod is threaded at one end to fit the jag. When the rod is carried in the rifle this threaded end (left-hand thread) is screwed into a hole tapped in the body to receive it; the other end is recessed and slotted for convenience of screwing it into the jag or the body.

As the cleaning-rod, when in its place in the rifle, did not project sufficiently for use in 'piling arms', this operation is effected by means of a divided swivel, which is attached to the upper band in addition to the ordinary swivel.

A wooden hand-guard is fixed over the breech end of the barrel to protect the hand when the barrel becomes hot. It is held in place by two steel springs, which clip round the barrel.

The rifle is provided with two sets of sights. The foresight and the backsight are fixed in the usual positions on the barrel.

The foresight is a square block, with a vertical cut through it, showing a fine line of light. Aim is taken by fitting this square in a corresponding notch in the *backsight*, so that lines of light of equal width can be seen on each side of it, and aligning the central line of light on the point to be hit. The lowest, or 'fixed' sight, is that for 300 yards. Using this sight a head and shoulders figure can be hit up to about 500 yards, without in either case aiming off the figures. The highest graduation is for 1,900 yards. The rifle is also fitted with *extreme range sights*. The front sight, which is called the dial sight, is graduated from 1,800 yards up to 3,500 yards. It consists of a bead fixed to a revolving index hand. The index is set to the correct distance, which is marked on the edge of the dial plate, and aim is taken by aligning the bead on the object aimed at through a circular hole in the aperture sight, which is raised into a vertical position when in use. Both these sights are on the left side of the rifle.

The sight protector is made of brass and forms a shield for the foresight and the muzzle of the rifle. It is issued for Naval service only.

The jag for the cleaning-rod is made of steel. It is tapped at one end to receive the cleaning-rod and slotted at the other end to receive the material used for cleaning.

The sword bayonet is two-edged and is fitted with wood grips. It is fixed under the barrel of the rifle; the bar and the head of the cleaning-rod fitting into a recess in the hilt. It is secured to the rifle by means of a spring and stud.

The scabbard is made of black leather, steel mounted, the locket being fitted with springs (to retain the bayonet). The sword bayonets and magazines are interchangeable but, owing to the necessity of manufacturing tolerances, some fit the rifle closer and better than others. For this reason, armourers should select those that are most suitable before numbering them to their respective rifles."

Less than three months after the introduction of the new British Service rifle, a new cartridge was approved for it. Its official name was CARTRIDGE, S.A. BALL, MAGAZINE RIFLE, MARK I, and a pattern to govern manufacture was sealed on 20th February, 1889. The case was made of solid drawn brass. A cap chamber was bored in the base to receive the cap and anvil. A central fire-hole communicated from the cap chamber to the interior of the case. The charge was $71\frac{1}{2}$ grains of black powder, pressed into the form of a pellet, with both ends slightly rounded. It gave a velocity of 1,850 feet per second. The bullet was lead, with a jacket of nickel covering all but the base, and weighed 215 grains.

The new cartridge was only a temporary expedient pending the development of a satisfactory British smokeless powder. This was soon forthcoming for later in the year, following experiments by Sir Frederick Abel, Sir James Dewar and Dr. Kellner, patents were

taken out in the names of Abel and Dewar on behalf of the Government for a new smokeless explosive. This was named **CORDITE** because of the string-like form in which it was made, and its composition was as follows:

Nitro-glycerine	58 per cent.
Guncotton	..	-	..	37 „
Mineral jelly	5 „

It had many advantages over black powder and was much more powerful. There was an absence of smoke after firing and only small quantities of fouling were left in the barrel. It did not develop high barrel pressures and was very safe to store and handle. At first it had one serious drawback. The greater heat it developed, in comparison with other powders, caused erosion, or wearing away, of the breech end of the bore of the barrel. This was eventually dealt with as will be seen in a later chapter.

A smokeless cartridge was a necessity for the new British rifle if the advantages of magazine fire were to be fully utilized. The smoke clouds left by a black-powder charge prevented a fast rate of accurate fire and made concealment of the firer virtually impossible. Experiments soon reached a successful conclusion and the first British smokeless rifle cartridge was introduced on 3rd November, 1891. This was named **CARTRIDGE, S.A. BALL, .303-in., CORDITE (MARK I)**. The cartridge-case, cap and anvil were similar to those of the black-powder cartridge except that the case had a larger fire-hole. The case was made of solid drawn brass, with formed cap chamber, separate anvil and one fire-hole. The cap was made of copper and contained .2 grains of cap composition. The charge was about 31 grains of size 3½ Mark I Cordite—60 strands. A glazeboard was placed on top of the charge, separating it from the base of the bullet. The bullet was flat-nosed and weighed about 215 grains. The core was composed of 98 per cent lead and 2 per cent antimony and was enclosed in a cupro-nickel envelope. The envelope was 80 per cent copper and 20 per cent nickel, with a permissible allowance of .5 per cent iron. The letter “C” denoting cordite, and the contractor’s initials and mark of cartridge, were stamped on the base. The cartridge developed a muzzle velocity of 1,970 feet per second and its mean pressure was 17.5 tons per square inch. Although already in use, cordite was not officially approved as a Service store until 9th May, 1893, and two months later a Mark II pattern of the cartridge just described was introduced. It differed from the Mark I in having a solid anvil, formed at the bottom of the cap chamber, and two fire-holes. The cap was slightly larger than the one which had been used with the separate anvil. Later, when charger-loading rifles were introduced in the British Service, this cartridge had rims made to suit the chargers.

Since the rifle first became his personal weapon, the British soldier has been taught to regard it as his best friend, and his first care to keep it clean, especially the barrel. A rod and jag had long been the medium for cleaning the bore but, on 26th April, 1890, these implements were superseded by a pullthrough. The pullthrough now introduced consisted of a cylindrical weight made of delta metal or hard brass, with a length of cord, or line, running through it. The line was a whipcord and the weight was attached to one end of it. The other end was doubled and spliced, a loop being formed to hold cleaning material such as a piece of flannelette. This pullthrough was about 48 in. in length and became the Mark II. An earlier pattern, the Mark I, was already in the Service but its use was restricted to armourers. It differed from the Mark II in that the line was of white leather. Consequent on the introduction of the pullthrough for the use of the soldier, the hole in the butt of the rifle, in which the jag had been housed, was enlarged to accommodate it. Four years later a new cleaning medium was introduced for use with the pullthrough. It took the form of a piece of wire gauze and was rolled on the two pieces of cord forming the pullthrough loop. Its object was to loosen the fouling in the bore of the barrel. It was embodied in a new pattern pullthrough, three inches longer than the Mark II, with a larger diameter cord.

On 8th August, 1891, it was decided to change the name of the Service rifle to LEE-METFORD MAGAZINE RIFLE, MARK I, and on 19th January, 1892, in consequence of various modifications, it became the LEE-METFORD MAGAZINE RIFLE, MARK I*. The principal modifications necessitating this advance in Mark were to the sighting system of the rifle. When the rifle was first produced the sighting was designed for a smokeless powder cartridge and the range graduations calculated on a velocity of 2,200 feet per second. The ballistics of the new cordite cartridge having now been definitely established, with a lower velocity than was anticipated, it became necessary to completely re-graduate the backsight to conform to the trajectory curve. The graduations were now based on a velocity of 2,000 f/s. The unusual method of "laying an aim" with the Mark I rifle had not been popular and was now superseded by the more straightforward "barleycorn" and "notch". With this system the firer had only to concentrate on ensuring that his barleycorn foresight was correctly positioned in the centre of the notch of the backsight and align the sights at the point he wanted to hit. The Mark I* rifle differed from its predecessor in the following instances: *Sighting.* The front sight was of the barleycorn pattern and it was set .023 in. to the left of the axis of the bore to compensate the tendency of the rifle to shoot to the left (Fig. 3). In rifles which were altered to Mark I* the barleycorn was pinned into the original sight block; in new rifles it was integral with the block. The notches

on the backsight were cut to an angle of 90° . The slide was reversible, one edge being straight. It had one vertical white line and no wind gauge lines. The range graduations were for ammunition giving a velocity of 2,000 f/s instead of 2,200 f/s. The leaf was graduated in intervals of hundreds of yards up to 1,800 yards, successive hundreds

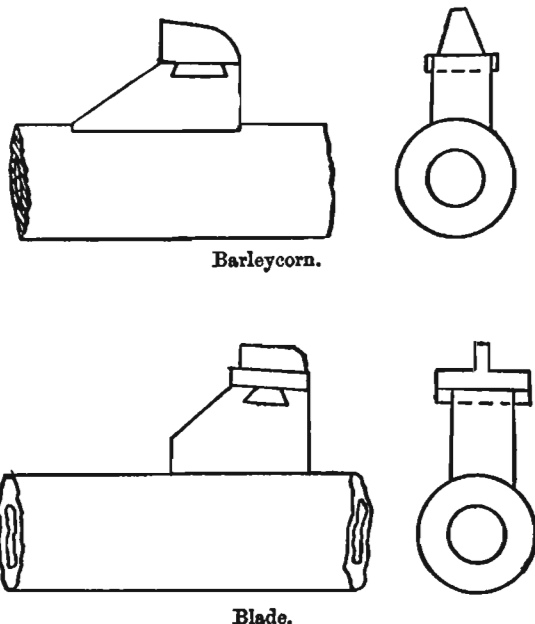

FIG. 3. Barleycorn and blade foresights.

The barleycorn was for many years the foresight for British Service rifles and carbines. It was eventually superseded by the blade.

being marked on alternate sides of the slide. Short lines, indicating 50-yard intervals, were marked on the outer edges.

The dial sight, for long distance shooting, was graduated from 1,600 yards to 2,900 yards.

The backsight was arranged for the following sighting with the leaf down in the horizontal position:

- (a) With slide at bottom of leaf—200 yards range.
- (b) With slide at top of leaf —500 yards range.

The ramp was made with a gentle slope and the slide could be moved to any point between the 200- and 500-yard positions, and it was graduated in hundreds of yards between these elevations. With the leaf in the vertical position, ranges could be obtained up to 1,800 yards. Sight protectors were issued with this pattern rifle.



Top: THE SNIDER CAVALRY CARBINE. *Centre:* THE MARTINI-ENFIELD CARBINE. *Bottom:* THE LEE-ENFIELD CARBINE. The Martini-Enfield and Lee-Enfield Carbines saw considerable service in the South African campaign, in the British Artillery and Cavalry. They were reputed to give very good service and an excellent standard of accuracy up to very long ranges.



Top: THE LEE-METFORD RIFLE. *Bottom:* THE LEE-ENFIELD RIFLE

Externally there are only small differences between these two rifles. The big difference was in the rifling. The barrel of the former embodied the shallow Metford segmental rifling and the latter the deeper Enfield concentric rifling.

A special match shooting slide, embodying wind-gauge vertical lines, was also made available to any Service personnel who wished to take part in competition target shooting.

The safety-catch was omitted, together with the recesses for it in the cocking-piece. This involved slight alterations in fitting, connected with the long-range aperture sight.

The body was cleared in rear to prevent jamming of cocking-piece.

The magazine-spring comprised four coils instead of three.

The mainspring was made of thirty-two coils of .049-in. wire instead of thirty-nine coils of .040-in. wire, and it was $3\frac{1}{4}$ in. instead of 5 in. in length.

The piling-swivel was made of stronger wire. It was the same width as the sling swivel and the opening between the ends, used for the purpose of "piling arms", was made wider.

The hand-guard was a modified pattern with the front corners rounded to facilitate removal from the rifle by hand. The front spring was shortened to lessen its grip on the barrel.

Stock-butt. The hole in the butt was altered to accommodate the pullthrough. A leather wad was placed at the bottom of the oil-bottle recess to keep the oil-bottle from contact with the head of the stock-bolt. The oil-bottle having been shortened, there was now room for it, together with a piece of flannelette and the pullthrough cord, in the oil-bottle recess.

A butt disc, made of brass, was screwed in a recess on the right side of the flat of the butt. This was for regimental markings and numbers for purposes of identification. A blued steel disc, instead of a brass one, was fitted to all D.P. arms (D.P. denotes weapons to be used for drill purposes only). Spare magazines were not issued with this pattern rifle, the practice had been found impracticable and discontinued the previous year.

A War Office committee was appointed in July, 1890, to study reports from various sources on the Mark I rifle and, on the strength of these reports, to put forward any suggestions for improvement they deemed advisable. They eventually recommended a new magazine holding ten rounds instead of eight, and other modifications including a simplified bolt-head. These changes necessitated a further advance in Mark and, on 30th January, 1892, the LEE-METFORD MAGAZINE RIFLE, MARK II, was officially approved. It differed from the Mark I* in the following features:

The barrel was lighter, being reduced in external diameter.

The body was modified to suit the new magazine; grooves being cut in both sides to improve the feed of cartridges from the magazine into the chamber. The resisting shoulders were cut with a screw pitch to facilitate opening the bolt after firing.

The bolt had the front end threaded internally (right-handed thread) to receive the stem of the bolt-head. The studs on the rib were modified

and undercut from the rear, and a circumferential groove was cut on the end of the bolt to secure the cover. The resisting lug was made slightly larger and the resisting shoulders of lug and rib were cut with a slight screw pitch to suit those of the body.

The bolt-head was made from a solid piece of steel, without dovetail. The tenon, or stem, was threaded externally with a right-hand thread so that it screwed into the bolt and required no bolt-head screw.

The bolt-cover was made of spring-steel, set to spring into its place on the bolt and no securing screws were needed. It was lengthened in front to form a bolt-head cover.

The butt-plate and trap were made of yellow metal and the heel of the butt-plate was enlarged to provide for the engraving of regimental markings.

The cut-off was altered to suit the new magazine. It was made slightly thinner and was furnished with a projection to hold it in place when closed.

The magazine was wider and shallower and held ten cartridges in two columns instead of eight in one column. The magazine-spring was "C"-shaped and made of spring-steel, the front end being bent over to engage the front of the magazine. The rear end was turned round, with a pin driven through for attachment to the platform.

The backsight slide was wider and marked with gauge lines.

The backsight leaf was graduated from 600 to 1,800 yards in hundreds of yards, the figures being on alternate sides of the leaf. Short intermediate lines on the outside edges indicated intervals of 50 yards. The sight bed was graduated from 200 to 500 yards, and the dial sight from 1,600 to 2,800 yards.

The stock fore-end was fuller at that point where it was gripped by the left hand in the firing position, and the hand grooves were omitted.

The nose-cap was altered to form both nose-cap and upper band.

The guard swivel was omitted and a butt-swivel fitted instead.

The clearing-rod, which prior to 22nd February, 1892, had been known as the cleaning-rod, was shortened. As it was no longer to be used for cleaning the bore of the barrel, the head-slot for holding cleaning material was omitted, and the head was fluted longitudinally. It was tapped at the head and at the smaller end to allow two rods to be screwed together. It was now long enough to use, when required, to insert in the muzzle and drive out a fired case when one became jammed in the chamber. It was not allowed to be used for any other purpose.

As a result of the modifications, the rifle weighed 9 lb. 4 oz., four ounces lighter than the Mark I pattern.

About three years later further modifications to the rifle were approved, the principal of which was the return of the safety-catch.

The omission of the safety-catch when the weapon was advanced to Mark I* had not proved popular in the Service; too much reliance had been placed on the cut-off as the safety device. A new form of safety-catch was now introduced which could lock the action in both the "cocked" and "un-cocked" positions. It consisted of a transverse bar which could be turned by a thumb-piece attachment. The bar was cylindrical but had a portion cut away so that when it was in position, as shown in Fig. 4 (A), the bolt was free to pass it. When in the position shown in Fig. 4 (B), the cylinder engaged in one or other of the two grooves cut in the bolt (according to whether the action was cocked or otherwise) and locked the action.

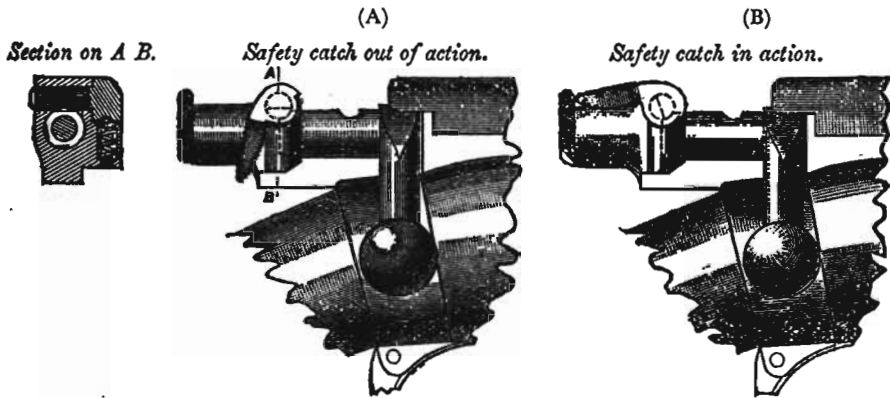

FIG. 4. Safety Catch.

The bolt had an extension of about one inch at the rear end, in which were two grooves for the operation of the safety-catch. The bolt was therefore special to this pattern of rifle. The cocking-piece was also lengthened and was fitted with the new safety-catch with pin and spring. The striker was made longer to suit the altered cocking-piece. The weapon now became the LEE-METFORD MAGAZINE RIFLE, MARK II*.

The rifle being too long a weapon to be conveniently carried by mounted troops, a shortened version for the use of the British Cavalry was approved for manufacture on 29th September, 1894. This was introduced as the LEE-METFORD MAGAZINE CARBINE, MARK I, and it differed from the rifle in the following particulars:

Length of carbine	3 ft. 3 $\frac{1}{8}$ in.
Weight „	„	7 lb. 7 oz.
„ „ magazine (empty)	3 $\frac{1}{2}$ oz.
„ „ „ (filled—6 rounds)	9 $\frac{1}{4}$ oz.

The barrel was 20 $\frac{3}{4}$ in. in length with the same internal dimensions as for the rifle.

The bolt had an extension at the rear end of about an inch, with two grooves in which the safety-catch operated. The bolt-lever was bent so that it lay close to the body of the rifle; the knob of the lever was flattened on top.

The cocking-piece was the same as described for the Mark II* rifle.

The nose-cap was combined with the upper band and had two wings to protect the foresight from damage. It was recessed at the rear to receive, and secure, the hand-guard.

The band was oval in form inside, had no shoulders, and passed over the hand-guard and the fore-end of the stock. It was held in position by a retaining spring in the under-side of the fore-end.

The hand-guard was wood and extended from the nose-cap to the backsight. It was secured to the stock fore-end by the band. To remove the hand-guard, the band screw was removed and the band forced up to the nose-cap. On raising the backsight, the hand-guard could then be removed.

The butt-plate was of the same shape and size as that of the Mark I* rifle, but was made of delta metal instead of iron.

The stock butt was smaller, except at the socket and butt-plate ends.

The trigger-guard had a loop for the magazine link across the front instead of at the side. It was recessed at the front to clear the link and the link-loop on the magazine when the magazine was assembled to the carbine.

The link-loop, which was brazed on across the case, was smaller, so that it could be passed through the trigger-guard.

The magazine was shallower and held six cartridges; the spring was therefore shorter, and was fitted to case and platform in similar manner to that for the Mark II rifle.

The backsight was designed for cordite-loaded cartridges. The leaf was graduated from 600 to 2,000 yards in intervals of hundreds of yards, and had short lines on alternate sides denoting intermediate 50-yard settings. The sight bed ramps were graduated from 200 to 500 yards. The slide was reversible, the depth of the bar being the same as that of the "V". It was marked with a centre-line and two wind-gauge lines. The carbine was not fitted with long range and aperture sights.

A sling bar was let into the right side of the butt and fixed by two screws inserted from the other side.

A sling loop was swivelled on the left side of the body.

CHAPTER III

THE FIRST LEE-ENFIELD

THE introduction of cordite as the propellant charge for the cartridge was responsible for the short life of the Lee-*Metford* rifle in the British Service. Cordite has a very high combustion temperature owing to its large content of nitro-glycerine. As already mentioned, it caused excessive erosion at the breech end of the barrel, as a result of which the "lead" (the front end of the chamber leading into the rifling) soon became worn and pitted. The first appearance of cordite erosion was minute pitting, or fissuring, and this soon developed into a gradual wearing away of the surface of the lead and the adjacent rifling. This part of a barrel is vital to what is called the "set up" of a bullet. This is the expansion of the bullet as it enters the rifling which largely determines stability in flight and ultimate accuracy. With black powder cartridges embodying a solid lead bullet the *Metford* barrel was usually reliable for an accuracy life of at least 10,000 rounds, but the lead bullet was no longer suitable. To withstand the greater pressures and heat generated by cordite it had to be enclosed in a cupro-nickel jacket. With the cordite charge and nickel-jacketed bullet the *Metford* barrel's accuracy life was very much shortened. A trial carried out in India in 1894 to determine the effect of cordite on Lee-*Metford* barrels resulted in the rifles used becoming completely unserviceable after only 4,200 rounds had been fired through them.

The answer to the problem was the introduction of a new and deeper form of rifling developed at the Royal Small Arms Factory, *Enfield Lock*. This had five grooves concentric with the bore of the barrel and about .002-in. deeper than the *Metford* grooves. The width of the lands (the portion of the bore between the grooves) was increased by about .007-in (see Fig. 5 for full details of the rifling in *Metford* and *Enfield* barrels). After much experimental work it was found that the deeper grooves and wider lands of the *Enfield* rifling offered greater resistance to the destructive effect of cordite erosion, and a consequent considerable increase in barrel life. *Enfield* rifling was eventually approved and embodied in what

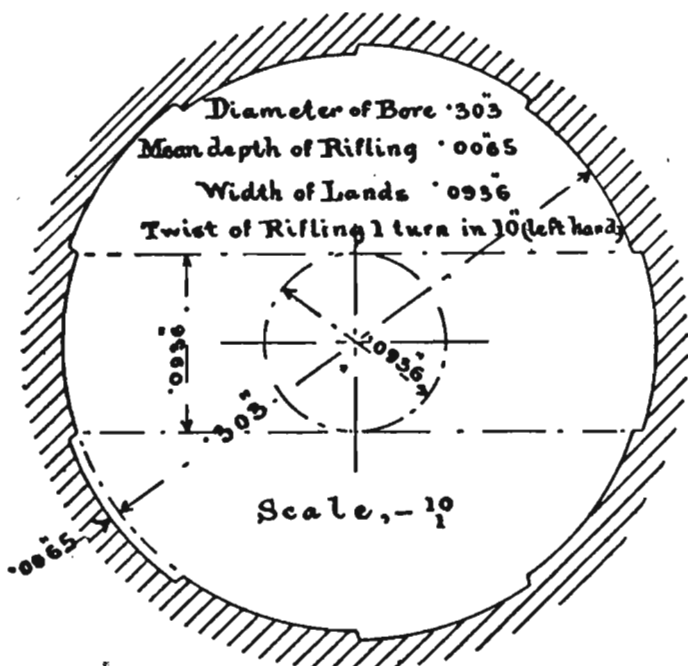

Enfield Rifling.

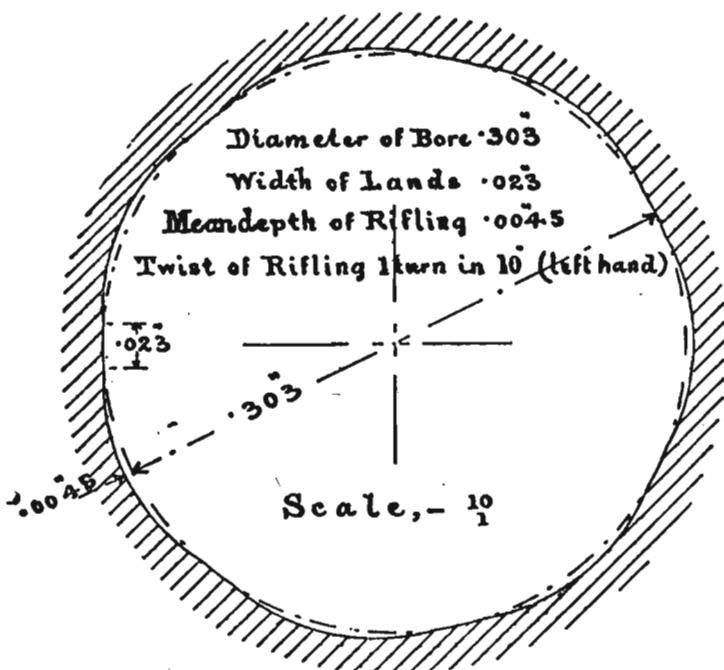

Metford Rifling.

FIG. 5. The Enfield and Metford forms of rifling.

was otherwise a Lee-*Metford* rifle. It was introduced in the British Service on 11th November, 1895, and was called the *LEE-ENFIELD MAGAZINE RIFLE, MARK I*. Apart from the barrel, it differed only in one other respect from its predecessor, the *Lee-*Metford*, Mark II**, and that was in the sighting. Although identical in form, the barley-corn foresight on the Enfield was fixed further to the left to allow for deviation, known as drift, of the bullet in that direction. The amount of deviation was calculated on the result of trials carried out with a number of weapons. The following description of the new weapon, together with the explanatory diagrams, are reproduced from the 1904 "*Text Book of Small Arms*", by permission of the Controller of H.M. Stationery Office:

"*The barrel*, which screws into the body, is strongly reinforced at the breech end, which is formed with a flat on its upper surface, known as the "*Knox-form*". This flat ensures the barrel being correctly breeched up to the body, so as to bring the sights vertical. The foresight block, with a long slope to the rear, is brazed on; the backsight bed is soldered on and secured by a screw.

Sights. The foresight is a barleycorn which is cut out of the metal of the block. It is set .05 in. to the left of the axis of the barrel to counteract the effect of the lateral vibrations of the barrel set up on firing. The backsight bed (1) has a ramp (2) on either side, sloping upwards to the front just clear of the inside edges of the opening in the backsight leaf. The backsight leaf is hinged to the rear of the bed. The cap (3) is dovetailed on to the end of the leaf, and is secured by a screw. It has a 90° "*V*" notch cut in it.

Elevations for 200, 300, 400 and 500 yards are obtained with the leaf down; the position of the slide for these distances being marked on the left side of the bed. The leaf is graduated on alternate sides for ranges from 600 to 1,800 yards. The even numbers are on the left, the intermediate 50 yards graduations being indicated by short lines.

The slide has also a 90° "*V*" notch on the top edge, and a central white line, and a wind-gauge line on either side are marked on it. The sides of the slide are roughened, and the under-side of the slide bears on the ramps of the bed when the leaf is down. Elevations from 1,600 to 2,800 yards are given by means of special long range sights. They consist of an aperture sight (4) attached to the left side of the body, and a dial sight (5) with pointer (6) attached to the left side of the fore-end. The aperture sight is a bar, terminating at the upper end in a flat button through which a peep hole (7) is bored. It pivots on a screw (8) and is held in a raised position or a lowered position by the aperture sight spring (9). The lower end of the spring is screwed to the body, whilst the upper end presses on the end of the sight bar; a small rib (10) on the inner surface of the

spring engaging in one or other of the cross cut notches (11) on the sight bar. The pointer (6) pivots on a projection (12) on the dial sight and is held in position by means of a screw (13). The curved spring disc (14) is placed under the head of the screw to enable the pointer to be held securely, and at the same time allow it to be easily moved. At the end of the pointer is a sharp-edged bead (15). The dial sight fits in a recess in the stock, and is held in position by a screw passing through the fore-end into the projection (16). The pin (17) prevents the dial sight from turning in its seating.

To use the long range sights the point (18) of the pointer is set to the required graduation line; the aperture is raised, and aim is taken through the peep hole, over the edge of the bead at the object.

The body. The sides of the body immediately in rear of the barrel seating broaden out underneath for the magazine. The usual opening is provided for inserting the cartridges into the magazine. The sides of the body do not form a complete circle over the rear end of the boltway, the body being slotted out to afford passage for the rib of the bolt (28) and for the extractor seating (37) of the bolt-head. Below the rear end of the boltway is a groove for the lug (30) on the bolt, and for the tongue (51) of the cocking-piece. From the front end of this groove a recess (19) is cut in the left of the body for the lug on the bolt. On the right side of the body is a rib (20). The rear end of this rib is cut away, and the head of the retaining catch (64) forms a continuation of it. Above the end of the rib is the resistance shoulder (21) for the rib on the bolt. Below the rib, and parallel with it, is a slot (22) for the cut-off. At the end of the body, and forming part of it, a socket (23) projects downwards, into which the butt fits and, in the centre of it, is a hollow threaded boss (24) for the stock bolt (98). Against the front face of this socket the rear end of the fore-end bears. Just in rear of the barrel seating, a gas escape hole (25) is cut through the left side of the body (Fig. 6).

The bolt. The bolt (26) is cylindrical, and has a bent lever (27) near its rear end, terminating in a round knob. A solid rib (28) is formed on the right side. It has two undercut projections (29) on it, one at each end, for the bolt cover. On the opposite side of the rib is a solid lug (30). This lug and the rib support the bolt on firing. The back end of the lug and the rib are cut on a screw pitch, fourteen threads to the inch. These correspond to the slope of the resisting shoulder (21), and the rear face of the lug seating (19), against which they bear. Underneath the rear end of the bolt is a recess, formed of a long groove (31), and a short groove (32); they are connected together in front by a cam-shaped face (33). The grooves are separated by the studs (34 and 34a).

Bolt-head. The bolt-head (35) has a screwed tenon (36) which screws into the front of the bolt. The screw thread is right-handed. A solid projection (37) on the bolt-head has a slot (38) cut in it for the

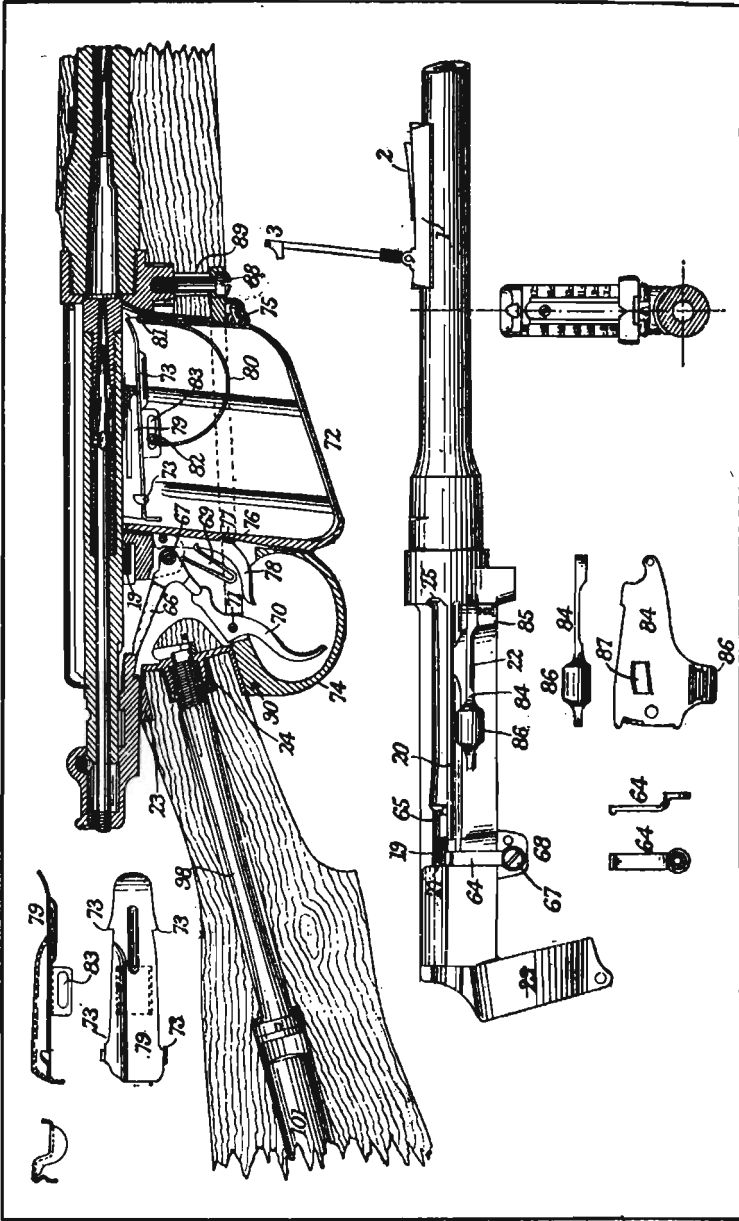

FIG. 6. Great Britain, Lee-Engfield Mark I*.

extractor (40). This pivots on a screw (39) and is pressed down by a V-shaped spring (41) let into the slot above it. A small pin (42) on the end of this spring engages in a hole (43) in the top of the slot, and is thus held in place. The extractor terminates in a claw which projects beyond the face of the bolt-head. A gas escape hole is provided in the left side of the bolt-head. The hook (44) on the right side of the solid projection engages the rib (20) on the body and prevents the bolt-head from turning.

Bolt cover. The bolt cover (45) is of sheet steel, spring tempered. It is secured to the bolt by being sprung under the undercut studs (29, 29) on the bolt rib, a slot being provided for the rear one. It is prevented from disengaging by the rear end, which is turned over, fitting into a groove (46) cut in the bolt in line with the bolt handle.

The mainspring. The mainspring is of .049 wire, has thirty-two coils, set to a length of $3\frac{1}{2}$ inches.

Striker. The striker (47) passes through the bolt, the rear end screwing into the cocking-piece (49). It has a collar (48) against which the front of the mainspring bears.

The cocking-piece. The cocking-piece (49) has a long tongue (50) projecting to the front and lying against the underside of the bolt. The front end of this tongue is the full bent (51), and the groove across it (52) forms the half bent. The stud (53) on the upper side of the tongue works in the two grooves (31 and 32) in the underside of the bolt. The rear end of the cocking-piece is cylindrical, and fits over the rear end of the bolt. At right angles to this cylindrical portion a hole (54) is bored for the stem of the safety catch (57). The head of the screw (55) in the end of the cocking-piece enters a recess (56) in the end of the striker, and prevents the latter from turning. The rear end of the cylindrical portion has a milled projecting rim to facilitate cocking the rifle.

Safety-catch. The safety-catch is provided with a stem (57) which fits into the hole (54) in the cocking-piece. This stem has a groove (58) cut in one side. When the finger piece (59) of the safety catch is raised, the stem (57) locks into one of the grooves (60, 60) in the rear end of the bolt. This prevents the cocking-piece and striker from moving in the cocked and fired positions, but, when the finger piece is turned down, the groove (58) in the stem allows the cocking-piece to pass over the end of the bolt. The finger piece is roughed above and below to afford a firm grip. The safety catch is held in the "safety" and "firing" positions by a small plunger (61), actuated by a spiral spring, both of which fit into the projections (62) on the cocking-piece. A nipple on the end of this plunger engages in one or other of the two holes (63) in the safety-catch according to its position.

Retaining catch. The retaining catch (64) is a flat spring secured by a screw to the right side of the body. The spring stands out slightly

from the body, and has a projecting edge which forms a continuation of the rib (20) on the body. To remove the bolt, it must be drawn back as far as possible, and the bolt-head pressed upwards to disengage the hook (44) from the edge of the spring. The projection on the bolt-head can then be turned upright and, in this position, will pass through the slot between the sides of the body.

The ejector. The ejector (65) is a small screw in the left side of the body. Its end projects into the boltway. On drawing back the bolt, it catches the back edge of the cartridge case, swinging it round to the right, clear of the rifle.

The sear. The sear (66), in the form of a bell crank lever, is pivoted underneath the body on the same screw (67) that holds the retaining catch. It works in a groove in the projection (68). It is actuated by a U-shaped spring (69), which also works the magazine catch. The long arm of the sear projects through a slot in the body into the groove of the cocking-piece. A short arm projects downwards, and is connected with the trigger by a knuckle joint.

The trigger. The trigger (70) works in a slot in the trigger guard. It is pivoted on the pin (71) and is connected with the sear as described above.

Action of the bolt mechanism. On raising the bolt lever, the cocking-piece is prevented from turning round with the bolt owing to the tongue (50) working in the groove in the body. The bolt-head is also prevented from turning by the hook (44), which engages the rib (20) on the body. As the bolt lever rises the cam-shaped face (33) on the underside of the bolt forces back the stud (53) on the tongue of the cocking-piece. This draws back the end of the striker clear of the face of the bolt-head, and partly compresses the mainspring. As the bolt lever is turned up, the front sloping face of the bolt lug (30) working against the front face of the recess (19) in the body causes the whole bolt to move to the rear. The fired case is drawn back with it, thereby effecting primary extraction. When the bolt has been turned round as far as it will go (that is until the rib (28) touches the left side of the body), the rib is opposite the gap between the sides of the body, the lug (30) is in the groove for the cocking-piece, and the bolt cover is projecting over the left side of the body. The bolt is then free to be drawn back, until the projection on the bolt-head strikes against the resisting shoulder (21). The stud (53) on the cocking-piece has then fallen into a recess in the front end of the short groove (32) of the bolt, and the compression of the mainspring is thus preserved. On pushing forward the bolt, the full bent of the cocking-piece engages the end of the sear, and the mainspring is further compressed, and the stud (53) on the cocking-piece passes the stud (34) on the bolt. On turning down the bolt lever, the bolt is forced forward by the sloping faces on the rear of the lug (30) and rib (28). This completes the compression

of the mainspring. The stud (53) is now in the long groove in the bolt. On pressing the trigger the sear is depressed and disengaged from the cocking-piece, which flies forward, and the striker fires the cartridge. If the bolt is not completely closed when the trigger is pressed, the stud (53) on the cocking-piece either causes the bolt to close automatically by striking against the rounded corner of the stud (34) between the grooves in the bolt which causes the bolt to turn down, or else the stud (53) strikes full against the stud (34) and prevents the striker flying forward. If then the bolt is closed by hand, the sear engages in the half bent (52) and the action is locked owing to the two studs (53 and 34) being side by side, thus preventing the rotation of the bolt (Fig. 7).

Magazine. The magazine (72) is a detachable sheet steel box with two flutings on either side which serve as guides for the projections (73) on the platform. It passes up through the prolongation of the trigger-guard (74), to which it is attached in front by a single spring link (75). It holds ten cartridges in two columns of five.

The back of the magazine has a rib with a notch (76) in it, in which a tooth (77) on the magazine catch (78) engages and holds it in the body.

The magazine catch (78) is pivoted on a pin to the same lug as the sear, and is actuated by the same spring (69). The tail of the magazine catch forms a finger piece, which projects into the trigger guard.

Magazine platform. The magazine platform (79) is elevated by a C-spring (80) of ribbon steel. One end (81) is bent over and hooks on to the front of the magazine. The other end is secured to a pin (82), the ends of which work in slots (83) in the sides of the piece riveted to the underneath of the platform. The left side of the platform is raised so as to bring the centres of the cartridges in one column opposite the edges of the cartridges in the other, and so present the cartridges in the two columns alternately at the mouth of the magazine.

Cut-off. The cut-off (84) is pivoted to a vertical screw in the projection (85) on the right side of the body. It works in a slot parallel to, and below, the rib of the bolt-head hook. It is provided with a thumb piece (86) for drawing it in and out. It is spring-tempered and set so as to press upward. The small projecting flat (87) on it acts as a catch against the side of the body, and holds the cut-off open or closed. In the latter position it keeps down the cartridges in the magazine out of the path of the bolt, and serves as a platform for single loading. When the cut-off is pulled out, the top cartridge in the magazine bears against the under face of the body with its rim projecting into the bolt-way. The bolt, in advancing, forces it into the chamber, and the top cartridge of the other column rises into position for loading next time. When the magazine is empty, it

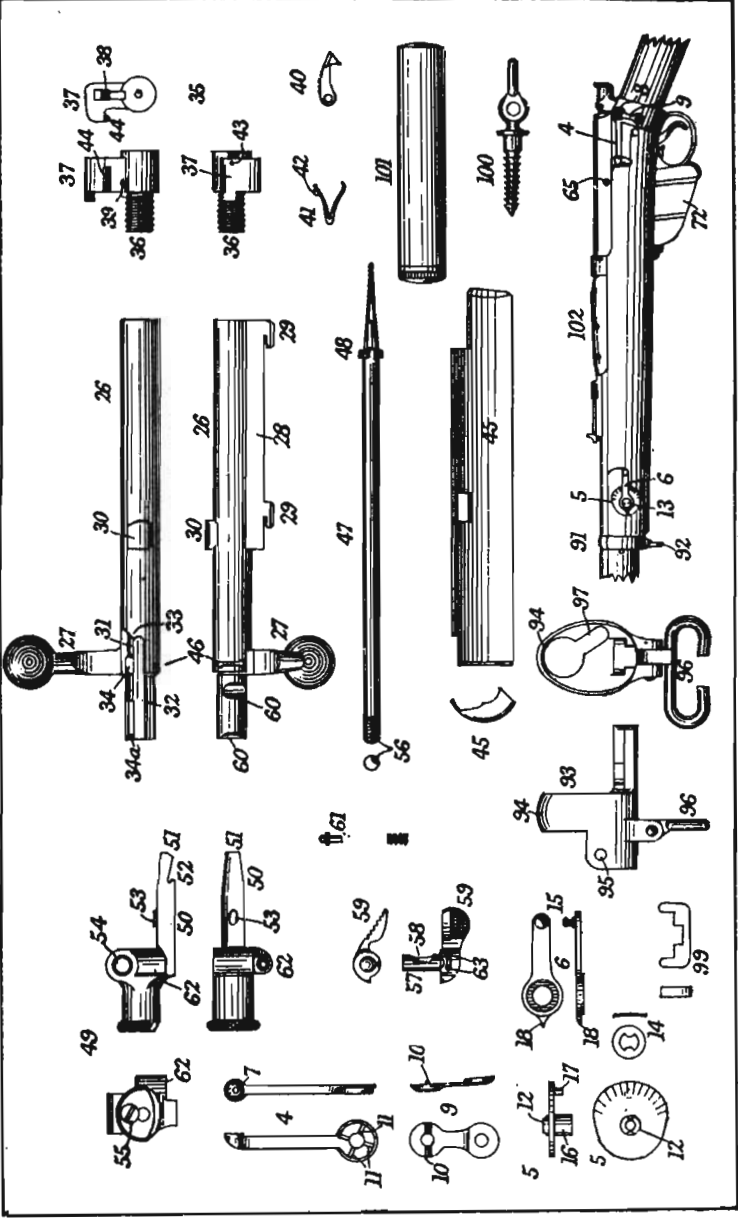

FIG. 7. Great Britain, Lee-Enfield, Mark I*.

is loaded by the insertion of single cartridges from above, the bolt being open.

The guard. The guard (74) is attached to the body by a screw (88) passing up through a collar (89) let into the fore-end; and by a small transverse screw (90) passing through ears on the bottom of the socket of the body.

Stock. The stock is in two pieces. The fore-end is held to the barrel by a lower band (91), which carries a sling swivel (92), and by the nose-cap (93), a band (94) forming part of which, passes over the barrel. It is secured to the fore-end by a transverse screw (95).

A sword bar is formed in front, which fits into the pommel of the sword bayonet. Underneath the nose-cap the piling-swivel (96) is pivoted on a screw. A diagonal slot (97) is cut through the front end of the nose-cap to afford a passage for the foresight.

Butt. The butt, which has a pistol grip, has its front end compressed and forced into the socket of the body. It is secured by the stock bolt (98), the front end of which is squared and passes through the front face of the socket. It fits into a square recess in a keeper plate (99) let into the rear end of the fore-end. The stock bolt is prevented from turning until the fore-end is removed. The butt-plate is of yellow metal. The heel is turned over, forming a tongue in the top of the butt. It has a hole in it closed by a trap operated by a spring, and is secured to the butt by three screws. The butt-swivel (100) is screwed into the underside.

Oil bottle. In a hole in the butt in rear of the stock bolt is carried a brass oil bottle (101) with a screw top. A leather washer is inserted between the oil bottle and stock bolt. On the top of the oil bottle is carried a cord pullthrough for cleaning the rifle barrel; its brass weight being carried in a small hole above the stock hole bolt.

Hand-guard. The wooden hand-guard (102) is attached by two spring clips to the barrel. It extends from the face of the body of the back-sight bed and its front corners are rounded off to facilitate removal.

Bayonet. The sword bayonet, Pattern 1888, Mark III, is double-edged, the blade being twelve inches long. The pommel and cross-piece are browned. The grips are removable to facilitate re-browning, and are secured by two screws and washers. It is attached to the sword bar of the nose-cap by the usual spring catch, the ring of the cross-piece fitting over the end of the barrel.

Scabbard. The latest pattern scabbard for the above bayonet is the Pattern 1903 of brown leather. The bottom is closed with a steel chape which is fitted inside the end of the scabbard. The steel locket is covered with a leather band tightly sewn on and secured by a wire rivet. Forming part of the band is a leather loop by which the scabbard is suspended from the waist belt."

Details of the rifle are as follows:

Length of rifle	4 ft. 1.5 in.
” ” ” with sword bayonet	5 ft. 1.45 in.
” ” barrel	30.2 in.
” ” sword bayonet	16 in.
” ” ” blade	12 in.
Rifling	Enfield system
Calibre303 in.
Grooves, number	Five
” depth0065 in.
” width0936 in.
Spiral	Left-handed, one turn in 10 in.
Magazine—Weight, empty	4 $\frac{3}{4}$ oz.
” filled	14 $\frac{1}{4}$ oz.
Sword bayonet—Weight	15 $\frac{1}{2}$ oz.
Scabbard	4 $\frac{3}{4}$ oz.
Sighting system	“V” notch and barleycorn
Weight of rifle (with empty magazine)	9 lb. 4 oz.

CHAPTER IV

MOSTLY CONVERSIONS, AND TROUBLES IN SOUTH AFRICA

THE cordite cartridge, with its higher velocity, provided another problem for solution. A number of ranges used for target practice were no longer regarded as safe and some had to be completely abandoned. In order to assist in solving this problem a new special practice cartridge was introduced on 26th March, 1895, and was called the PRACTICE SHORT RANGE CORDITE .303-in. S.A. BALL CARTRIDGE, MARK I. The charge and weight of bullets were so adjusted as to produce a low velocity, in order that the cartridge could be used on ranges considered unsafe for the Service round. The case, cap and anvil were similar to those of the Mark II cordite cartridge. The exterior of the case was darkened by a bronzing liquid for a length of 1.4 in. from its mouth, so that it could be easily distinguished from the Service round. The charge consisted of about 9 grains of size $3\frac{3}{4}$ cordite, cut in slices .007 in. thick, and kept in position by a paper cup over which were placed two wads. The bullet consisted of a cupro-nickel envelope filled with lead. It weighed 150 grains and was more pointed at the nose than the service bullet. It was secured in the case by three indents in the case neck. The wrappers and labels were of yellow paper, printed with black letters. The distinguishing mark was the same as for the Service cartridge, but in black. Owing to its lower velocity, the graduations on the Service rifle sights were not suitable for this cartridge, and special instructions had to be issued regarding its use. Its accuracy was not of a high standard and it was declared obsolete on 13th August, 1897.

The introduction of Enfield rifling and the cordite cartridge caused the conversion of many rifles and carbines likely to be retained in the British service. Lee-Metford and Martini-Henry weapons of .45-in. calibre were still in use in considerable numbers for Home Service. Units of the Field, Garrison, and Militia Artillery, the Army Service Corps, the Ordnance Corps, the Royal Engineers, and the Rifle Militia and Volunteers still had these arms. Even the Snider-Enfield had not entirely disappeared and was still in use in



AN OPPONENT OF THE LEE-METFORD

The Mauser Rifle used by the Boers in the South African campaign. It had excellent accuracy, of which full use was made by the Boer sharpshooters. In the top illustration the name of the Boer owner can be faintly seen roughly carved on the left face of the butt. This rifle is in the Inspectorate of Armaments' Pattern Room at Enfield Lock.



Top: THE LEE-METFORD CARBINE. *Bottom:* THE LEE-METFORD RIFLE

The Lee-Metford Rifle, at first known as the Magazine Rifle, was the first British Service Rifle to embody the Lee bolt action and magazine. These were named after the inventor, an American, James P. Lee, of Ilion, New York. The rifle was introduced in 1889. It was too long for mounted troops and a shortened version, the CARBINE, was approved for manufacture five years later.

certain Volunteer and Irish Militia formations. Conversion programmes were carefully planned to cause the least possible interference with manufacture of the new Lee-Enfield rifle.

The first weapons to be converted were a number of Martini-Henry Mark III rifles. On 4th October, 1895, a pattern was sealed to govern the work, and the converted rifles were called **MARTINI-ENFIELD, MARK I**. The principal alteration was the fitting of new .303-in. Enfield barrels, which were three inches shorter than the existing ones. When converted, the rifle had an overall length of 3 ft. 10½ in. (without the bayonet), and weighed 8 lb. 7 oz. The sighting arrangements consisted of a backsight with a "V" sighting notch, and a barleycorn foresight placed centrally on the barrel. It had not been found necessary to offset the foresight as with the Lee-Enfield rifle. The hand-guard differed from that of the Lee-Netford rifle in being a little longer and having only one retaining spring. The rifle was later fitted with an adjustable foresight in three heights, each differing by .015 in., and became the **MARTINI-ENFIELD, MARK I***. An order for 48,000 Mark I Martini-Enfields was placed with the Royal Small Arms Factory, Enfield, most of which were required for Canada. This order was afterwards cancelled and 40,000 Lee-Enfields were ordered instead. Two hundred Mark I Martini-Enfields were made, fitted with sword bayonets, sighted for black powder cartridges, and went to Western Australia.

On 6th November, 1895, the first carbine to embody the Enfield rifling was introduced. This was for Artillery units of the British Army and was a conversion of the Mark III Martini-Henry rifle. The conversion was similar to that of the Martini-Enfield rifle except that the new barrel was shorter, being only 21 inches in length. The new carbine became the **MARTINI-ENFIELD ARTILLERY CARBINE, MARK I**. It was 3 ft. 1⅞ in. long and weighed 7 lb. 4½ oz.

The **MARTINI-ENFIELD RIFLE, MARK II**, made its appearance a few months later. This was a conversion of the Martini-Henry rifle, Mark II, and a pattern was sealed to govern conversion on 11th February, 1896. It followed the same lines as previous conversions, the principal feature being the fitting of new .303-in. Enfield barrels. Although the same length as the Martini-Enfield rifle, Mark I, the Mark II was 2 oz. lighter. As in all conversions of Martini-Henry rifles, the body was filed down in front of the block to enable the sights to be used when the backsight leaf was down. The barrel, hand-guard and stock fore-end were special to this pattern rifle, a number of which were made for South Australia. The rifle was later fitted with an adjustable barleycorn foresight, when it became the **Mark II***.

A carbine for the British Cavalry was the next new weapon to be made embodying Enfield rifling. A pattern was sealed on 17th

August, 1896, and it was called the LEE-ENFIELD MAGAZINE CARBINE, MARK I. It differed from the earlier Cavalry carbine, the Lee-*Metford*, Mark I, in the form of rifling, height and position of foresight, graduations on the backsight leaf, and height of cap of backsight. The sling fittings were omitted and it had a leather cover for the backsight. The magazine held six cartridges and took the same ammunition as the Service rifle. The sighting system was a backsight with "V" sighting notch and a barleycorn foresight. The foresight was fixed .05 in. to the left of centre as on the Lee-*Enfield* rifle. Particulars of the new weapon were:

Length of barrel	20 $\frac{3}{4}$ in.
Calibre ,, ,,303 in.
Rifling	Enfield concentric
Grooves (number)	Five
,, depth005 in.
Lands, width0936 in.
Spiral (left-hand)	One turn in 10 in.
Length of carbine	39 $\frac{1}{8}$ in.
Weight ,, ,,	7 lb. 7 oz.
,, ,, magazine (empty)	3 $\frac{1}{2}$ oz.
,, ,, ,, (filled)	9 $\frac{1}{4}$ oz.

The leather backsight cover fitted to this weapon was now approved for use on the Lee-*Metford* carbine.

Two more converted carbines were introduced during August, 1896. They were the MARTINI-ENFIELD CAVALRY CARBINE, MARK I, and the MARTINI-ENFIELD ARTILLERY CARBINE, MARK II. The former was a conversion of the Martini-*Henry* Rifle, Mark II, and the latter was converted from the Martini-*Henry* Artillery Carbine, Marks I and III. The conversions were on similar lines to those already described, 21-in. Enfield barrels being fitted. The Cavalry carbine was fitted with a leather cover for the backsight and the only part special to the weapon was the barrel. The Artillery carbine differed from its predecessor, the Mark I, in the body and stock fore-end. The foresight was fitted with protecting wings. For full details of the two carbines, see Appendix "B".

By 1897 considerable progress had been made with the conversion programme, although there were still a lot of arms in use which had *Henry* and *Metford* barrels. An official War Office list of rifles and carbines in the British Service showed the following to have Enfield barrels:

- Rifles*— Magazine Lee-*Enfield*, Mark I.
 Martini-*Enfield*, Marks I and II.
- Carbines*—Magazine Lee-*Enfield*, Cavalry, Mark I.
 Martini-*Enfield*, Artillery, Marks I and II.
 Martini-*Enfield*, Cavalry, Mark I.

Weapons in the Service, other than those with Enfield barrels:

<i>Rifles</i> —		
Magazine Lee-Metford, Marks I*, II and II*	(.303-in. Metford rifling).	
Martini-Henry, Marks II, III and IV	(.45-in. Henry rifling).	
<i>Carbines</i> —		
Magazine Lee-Metford, Cavalry	∴	} .303 in. Metford.
Martini-Metford, Artillery, Marks I*, II* and III	∴ ∴ ∴ ∴	
Martini-Henry, Artillery, Marks I, II and III	∴ ∴ ∴	} .45-in. Henry.
Martini-Henry, Cavalry	∴ ∴ ∴	

For full details of all these weapons, see Appendices “A” and “B”.
 Owing to the prevalence of misfires, due to lightly-struck cartridge caps, it was decided on 21st January, 1898, to increase the striker protrusion of all .303-in. rifles and carbines in the Service. The high limit of protrusion of .041 in. was increased to .042-in., and the low limit was raised from .037 in. to .040 in. It was also decided to remove the “D” loop for the sling from all carbines. This had been positioned on the left side of the body near the trigger-guard.

During the same month instructions were issued that all Lee-Metford rifles when requiring new barrels should have their old ones exchanged for Enfield barrels. The exterior form of the Enfield barrels was similar to the Metford barrels which they would replace and, in order that they should be easily distinguishable, they were stamped with the letters “E.Ix” on the Knox-form.

A few months later a foresight protector was introduced for all magazine rifles. It was made of steel and was intended to remain on the rifle and only be removed for purposes of cleaning. It provided no protection for the muzzle of the barrel. By sliding it towards the muzzle, and turning the hood to one side, the front sight was exposed so that aim could be taken. To remove the protector from the rifle the hood was turned to the left.

During 1898, British Infantry units engaged in operations on the North-West Frontier of India were asked to report on the Lee-Metford Mark I* rifles with which they were armed. The general efficiency of the rifle was reported to be good and it appeared to be popular with the troops. It had undergone severe tests in dust, wet, heat and rough usage, and had stood up to them well. Although many of the units had not had occasion to resort to magazine fire, it was generally agreed that the reloading of magazines by single rounds was a rather clumsy business and took too long. In the heat of action there might be some difficulty in carrying out this operation and there was a real need for some form of clip, or charger, loading. The 1st Bn. The Royal West Kent Regiment did not like having to load their magazines by hand with single rounds, but they

were of the opinion that this method caused no practical disadvantage. If men, after discharging eight or ten rounds, had been unable to check an enemy's advance, their morale would be so impaired that it would make no difference to them whether they could put in a clip of eight cartridges, or whether they had to load them one at a time. In several instances where they had used magazine fire, jamming of the rounds had occurred, and this had usually been due to the magazine springs having become weakened. A smart tap on the bottom of the magazine sometimes remedied this defect. Sand had often proved very troublesome by getting into the magazines and causing the cartridges to jam and miss-feed. On the question of accuracy and lethal effect of ammunition, there was unanimous approval for a cartridge made in India known as the Dum-Dum Mark II Special. This was considered to be much superior in every respect to the normal British cartridge for the Lee-*Metford* rifle. The 1st Bn. The Buffs reported having fired some 40,000 rounds of Dum-Dum Special and gave high praise on its performance. Nearly all the firing they had done had been at long ranges. Volleys had been kept up consistently and, as far as could be ascertained, the results had been good. They considered the enemy did not like facing the Lee-*Metford* rifle and Dum-Dum ammunition. Some of the enemy were evidently using the same type of cartridge as the British, as the 2nd Bn. The Yorkshire Regiment reported a fatal casualty from a bullet of Dum-Dum Special pattern, fired from a distance of about 1,000 yards. Despite this long range, this bullet had passed through a soldier's body and lodged in the "D" of his waist-belt, after previously passing through his mess-tin and thirteen folds of the rolled great-coat of the man in front of him. The bullet was in good shape and not distorted in any way. Considerable shooting was reported to have taken place with effective results at distances up to 2,000 yards. Units engaged in operations in the Sudan also submitted reports on their Lee-*Metfords* and ammunition, and their experiences were similar to those of the troops in India. There seems little doubt that the Lee-*Metford* rifle and Dum-Dum ammunition was a formidable combination, and was used with considerable confidence in these two campaigns.

The Dum-Dum bullet, named after its place of manufacture near Calcutta, India, differed from the bullet in the Mark II British cartridge in that the rounded nose was left uncovered by the cupronickel jacket. On impact the bullet mushroomed, and inflicted a more serious wound than the normal bullet. It appears to have had much greater stopping power than the Mark II cartridge normally used with the British rifle. The name "Dum-Dum" has often been misapplied to bullets which have been deliberately maltreated by having their noses cut off or flattened.

On 17th October, 1899, a new cartridge was introduced for use in

British Service rifles. This was the CORDITE .303-in. S.A. BALL CARTRIDGE, MARK V, and the following are the official details of the round:

Case.—Solid drawn-brass with cap chamber formed in base. Fixed anvil, two drilled fire-holes, letter "C" stamped on base. The case was not lacquered.

Cap.—Made of copper, containing .6 grain of cap composition, pressed in and varnished (sometimes covered with tinfoil).

Cap composition.—

Chlorate of potash	14 parts.
Sulphide of antimony	18 "
Fulminate of mercury	8 "
Sulphur	1 part.
Mealed powder	1 "

Charge.—About 31 grains of size 3 $\frac{1}{4}$ cordite—60 strands.

Wad.—A glazeboard disc placed on top of the cordite.

Bullet.—Hollow-nosed. Core consisting of 98 per cent lead and 2 per cent antimony, enclosed in a cupro-nickel envelope. The envelope was solid, drawn from an alloy comprising about 80 per cent copper, 20 per cent nickel, and about .5 per cent iron. The core was secured by turning over the envelope and pressing it into a groove formed round the base of the core. A cavity about .35 in. deep and .1 in. diameter was punched in the nose of the bullet; the punch carrying a small disc of the envelope to the bottom of the cavity. A cannellure, coated with beeswax, was formed round the bullet near its base. The bullet was secured in the case by coning and three indents. The length of the bullet was between 1.28 in. and 1.244 in. The test for "bullet pull" (security of bullet in case) was "not less than 60 lb."

The overall length of the cartridge was between 3 and 3.075 in. The immediate predecessors of this cartridge, Marks III and IV, never went into general production. The Mark IV differed from the Mark V only in the bullet being slightly shorter and the core being made of pure lead. The Mark III had a metal cup, or tube, inserted in the nose of the bullet. Only a small number of these were made.

During 1898 and 1899, various experiments were carried out with protective greases consisting of varying proportions of mineral jelly and beeswax, and mineral jelly alone. The object was to obtain a better material than rifle oil for cleaning and preserving the bore of the barrel after firing cordite cartridges, and to preserve the exterior metal parts of the weapon from rust. Various trials, carried out under very adverse conditions, showed that mineral jelly answered

all the requirements for which rifle oil was being used. It also had the marked advantage of not being so liable to dry up as rifle oil. This made it a much better preservative against rust. It was consequently introduced into the Service for the purposes of cleaning and preservation, in place of rifle oil. Rangoon oil was retained for the purpose of lubricating the working parts of weapons.

On 19th May, 1899, both the Lee-Enfield Rifle and Carbine were advanced to MARK I*. The Advance in Mark was consequent on the abolition of the clearing rod. Patterns to govern manufacture differed from those of the Mark I in the omission of the clearing rod and the hole, groove and rod nut in the stock fore-end, and the hole in the nose-cap. In the case of the Carbine, the hole for the clearing rod band spring was also omitted. The abolition of the clearing rod was extended to all .303-in. rifles and carbines in the British service, the improved cartridge now in use making the implement unnecessary. On the following 12th July the last of the Martini-Enfield Artillery Carbines was introduced. This was the MARK III, and it was a conversion of the Martini-Henry Rifle, Mark II. (For details of the weapon, see Appendices "B" and "C".)

Despite the many conversions to Enfield rifling which were being made, the Metford barrel was still in production and, on 12th March, 1900, the MARTINI-METFORD RIFLE, MARK II, was approved. The pattern to govern manufacture had been sealed at an earlier date as the Martini-Henry Rifle .303-in., Mark VI, but the weapon had never been made as such. It was similar to the Martini-Metford, Mark I, which had been introduced on 3rd July, 1889, and which had originally been sealed as the Martini-Henry, Mark V. The Martini-Metford, Mark II, was a new arm, and was produced as part of an uncompleted contract for Martini-Henry rifles; the manufacture of rifles of .45-in. calibre having ceased. The weight of the rifle was about 9 lb. 4 oz., and the barrel weighed 3 lb. 8 oz. It was fitted to take the Pattern 1888 sword bayonet. Although nearly 10,000 of these rifles were made by private manufacturers, none were issued to the Service in the United Kingdom. Eventually a number of them, mostly sighted for cordite cartridges, were issued to Natal, Zululand, Jamaica and Western Australia. A few, sighted for black powder, were also sent to Natal.

Another new carbine was introduced for the British Land Services on 1st August, 1900. It was called the LEE-ENFIELD MAGAZINE CARBINE, and it differed from the Lee-Enfield Carbines, Marks I and I*, in the following particulars:

The barrel was special to this carbine and increased in diameter at the muzzle end for the purpose of fitting the Pattern 1888 sword bayonet.

The sighting was the same as for the Martini-Enfield carbine, Mark III ("V" notch in backsight and barleycorn foresight).

The stock fore-end and the hand-guard were special to the arm, the hand-guard being secured by two springs.

The carbine was 3 ft. 4¼ in. in length and weighed 7 lb. 8 oz. The foresight was fitted with protecting wings.

The campaign in South Africa had only been in progress a short time when the importance of accurate shooting was clearly established. Weapons were required which not only gave a high standard of accuracy but were so correctly sighted that shots would hit where they were intended. It was at short ranges that the Boers excelled at accurate shooting and, so efficient were they in field-craft and concealment, that the targets they offered to the British were usually very small and of short duration. Hitting with the first shot was of the utmost importance as a second chance was seldom presented. In a speech at Bisley on 20th July, 1901, the late Field-Marshal Lord Roberts stated that the two points which were forcibly brought home to him by the war in South Africa were the necessity of making soldiers good shots and of developing their individual intelligence. No other qualifications would make up for inferior shooting—the men would be valueless as soldiers if they were not experts in the use of the rifle. He appealed to the patriotism of the British people not to show unreasonable opposition to the construction of ranges and to help by all means in their power to perfect the Army in rifle shooting, on which depended its future efficiency. The British Army's style of shooting was most effective at the medium and longer ranges but was considered to have little chance against the Boers at distances of 150 yards and under. This was considered to be the maximum distance at which it was possible to distinguish the head of a man when he was shooting from a trench or from under cover. Inferiority at short distance snap shooting was attributed to lack of sufficient training in peace time.

From reports from British units engaged in this campaign it seemed that there was another important factor militating against the troops, the inaccurate sighting of their weapons. Subsequent events showed that far too little attention had been paid to this most important feature of any arm. One of the most defective weapons in this respect was the new British Service rifle, the Magazine Lee-Enfield. Although this rifle had been in production for several years, only a comparatively small number had gone overseas. About 35,000 to 40,000 had been taken to South Africa by Reservists, a number were in the hands of Colonial contingents, and about 6,000 were being issued to the Imperial Yeomanry. It is believed that it was the Middlesex Company of this Regiment that first reported the trouble. They had found that the faulty sighting of their rifles caused them all to shoot consistently to the right. How this defect was eventually dealt with will be described in the next chapter. The problem facing the Small Arms Committee was the

immediate correction of some 65,000 rifles in the hands of troops, with a further 200,000 in Army Ordnance Stores and due for delivery by the manufacturers.

In May, 1900, a questionnaire was sent by the British War Office to Commanding Officers of Regiments of Cavalry, Battalions of Infantry, and other units who had been on active service in the South African campaign. Its object was to obtain information from officers and men on the equipments they had been using and to find out how requirements were being met on the field of battle. Thorneycroft's Mounted Infantry were armed with Martini-Enfield, Lee-Metford, and Lee-Enfield rifles, and their report to the War Office contained some interesting criticisms. They had no complaints about the accuracy of their arms, but the sighting was most unsatisfactory. At ranges of 200 yards, where correct sighting was vital, their rifles often shot 12 in. high of the mark at which they were aimed, and the error increased with distance. At long ranges they considered it impossible for a man to hit an object without having previously sighted his rifle for the particular distance at which he was shooting. Most of their rifles also shot to the right and, as the Boers offered such small targets, the men of Thorneycroft's found it very difficult to get effective results. The foresights on the British rifles were considered to be too coarse, and the finer sighting of the Mauser rifle used by the Boers was preferred as it permitted greater accuracy. They would have liked a spring clip, similar to that on the Mauser, fitted to the slides of their backsights and believed that a great improvement would be effected if some form of clip loading could be introduced. The actions of all the British rifles were considered to be good but there was a desire for longer hand-guards which were thought to be more serviceable, especially in hot climates. A tendency for rifle butts to work loose was reported and many had actually fallen off. This was a serious defect as the long screwdrivers necessary to reach the securing screw were not usually available. The Mauser rifle with the butt and stock in one piece was considered superior in this respect, and its double pull-off was liked much better than the heavy single pull of the Lee-Metford.

The general opinion of Gough's Composite Regiment of Mounted Infantry was that the carbine was as good as the rifle for shooting at distances up to 1,800 yards, but failed beyond that range. A great deal of shooting took place at 2,000 to 3,000 yards and was very effective when distances had been correctly judged, and at these long distances a rifle would have been especially useful to all mounted troops, many of whom were only issued with the carbine. It was considered that, if armed with rifles, small patrols would have been able to impose on the Boers and prevent the near approach of scouts. They believed that all British mounted infantry should be

armed with rifles, and also the cavalry if carrying difficulties could be overcome. Gough's men did not like the backsight "V" on their weapons and suggested that it would be much improved if the shoulders were widened, as this would enable a much quicker alignment of the sights. They would also have liked a distinct white line from the bottom of the "V", to rapidly attract the eye. A quick aim and shot had become a matter of great importance. The protruding bolt-lever on their rifles was much disliked. Unlike the carbine, on which the bolt-lever folded down snug against the body, the rifle lever was easily knocked up. This allowed the bolt to open and sometimes fall out of the rifle, probably resulting in a lost bolt or broken bolt-head. The charging of magazines by single rounds was considered too slow and cumbersome and some form of clip loading was almost a necessity. They thought the cut-off was definitely needed as it was a means of preventing unauthorized magazine fire and wastage of ammunition. Apart from these criticisms, Gough's Regiment had much praise for both Lee-Metford and Lee-Enfield rifles as very accurate and serviceable arms.

A Royal Welsh Fusilier unit praised their rifles' accuracy and ability to make a good group on a target but, owing to defective sighting, the group was not often where it was intended. Their experience had been that only in exceptional cases could a good marksman select a Government rifle at random and hit a small object such as a man's head or an 8-in. bull's-eye at a distance of 200 yards, without a great deal of practice with that particular rifle. This criticism applied to Lee-Metford, Lee-Enfield and Martini-Henry rifles alike. Most of the unit's arms grouped their shots to the right of the object at which they were aimed and the error increased progressively with the distance at which they were firing. This inaccuracy of sighting was largely responsible for the painting and doctoring of sights which prevailed amongst even their best shots. It was considered unreasonable to expect Government rifles to shoot truly as well as accurately while sights were interchangeable; each weapon should have been individually sighted. Modern conditions of war demanded quick, accurate shooting, and the Fusiliers thought this would be better obtained with a "bead" pattern foresight in place of the "barleycorn". To further improve definition they would have liked a bone or platinum dot in the centre of the "bead", which should be protected against injury by a semicircular permanent guard with the top removed to admit light. The advisability of issuing wind-gauges to all marksmen in a unit was worth consideration, and the means of correction for "drift" should be embodied in the backsight instead of being allowed for by positioning the foresight. They also believed that an aperture backsight would be a great advantage, especially to those whose eyesight was not of the highest standard and who found

difficulty in getting a clearly-defined foresight. Clip loading was considered to be preferable to the existing method, as being quicker, easier and less dangerous. Complaints were made of loose-fitting bolts which made them liable to become clogged by dust and sand, and consequently the actions should be made easier to dismantle for purposes of cleaning. There was also a preference for a hand-guard extending to the lower band in order that the rifle could be held further forward when the barrel became hot.

The Carabineers were satisfied that the carbines, with which they were armed, were sufficiently accurate to shift the Boers, or stop them advancing, at distances up to 2,500 yards. They greatly favoured the introduction of some form of clip loading similar to that of the Mauser rifle. They had received complaints in the unit that their carbines were undersighted, but this was thought to be attributable to incorrect distance judging rather than defective sighting. Correct distance judging by eye proved a difficult problem in South Africa and there was much under-estimation of ranges. A clear moist atmosphere, unbroken intervening space, and the sun in rear were considered to make a range appear shorter than it actually was. A "mirage", or heat shimmer, causing the objective to apparently move about, was a common occurrence in South Africa and added to the difficulty of correct estimation.

Nineteen-hundred was certainly a year of troubles, not all of which emanated from South Africa. In May of that year the British War Office received a complaint from the Queensland Defence Force of the inaccurate sighting of their Martini-Enfield rifles. Over 4,000 of these weapons had recently been issued to the Queensland Force and various rifle clubs in the State. However, investigation revealed little real cause for the complaint. Prior to this issue of Martini-Enfields the Queensland marksmen had been using .45-in. Martini-Henry rifles. At target practice, when a shot missed the target, it was customary to observe the strike of the bullet, from which sights were adjusted to correct the error. The strike of the small .303-in. bullet used in the new rifles was much more difficult to observe than that of the .45-in. Martini-Henry and marksmen who missed their targets were often at a complete loss to know how to correct their errors. The trouble disappeared as the men became more accustomed to their new weapons. There appeared to be a general impression that the Martini-Enfield was inferior in accuracy to the Lee-Enfield and Lee-Metford, but this was not borne out by the experience of the inspectors in England who tested the weapons. The standard of accuracy was practically identical for all three arms. The Martini-Enfield, however, shot in a slightly different direction to the other two, and the foresight was consequently placed centrally on the barrel. This was attributed to differences in the methods of stocking. The foregoing reports give a reasonably

true picture of the British Army's opinion of its rifles and carbines, largely based on experiences on the field of battle. Subsequent events showed the influence of these, and many similar reports, on British weapon development.

During October, 1900, a somewhat unusual trial took place on open ranges near Aldershot. It was probably prompted by events in South Africa and was an attempt to find out how effective Lee-Enfield and Lee-Metford rifles could be at long distances. Special targets consisting of khaki-coloured canvas screens, each 30 yd. in length and 4ft. 2 in. in height, were placed at 20-yard intervals, the bottom edge of each target being $1\frac{1}{2}$ ft. clear of the ground. The nearest line of targets to the firers was 2,200 yards distant, and they were only just visible without the aid of binoculars. The remainder of the targets were hidden to the firers owing to the ground falling away to the rear. The firing squad consisted of forty picked men from a battalion of Highland Infantry and each man fired fifty rounds by both independent and volley firing. At the very long distance at which this firing was taking place the dial sights on the left side of the rifles were the only means of sighting and the muzzles of the rifles had to be elevated to a high angle. This position was a most uncomfortable one to maintain and accuracy was affected by fatigue of the firers towards the end of the trial. Accuracy was further disturbed by a wind which, though light at the commencement of shooting, increased in strength towards the afternoon. Its effect at this long range must have been considerable and, under the circumstances, the results were surprisingly good. Of the 2,000 rounds which were fired, 348 hits (17 per cent) were recorded on the targets. The greater part of these were direct hits and a large number of bullets were picked up amongst the screens. The markers reported that quite 50-60 per cent of the shots fell amongst the targets or struck the sloping ground immediately in front of the first ones. In summing up the result of the trial it was observed that: "A bullet striking a man direct at this range would no doubt kill or wound him. Owing to the sharp angle of descent of the bullet it would be difficult for the man to find cover. The bullet had, however, lost a great deal of its penetrating power and any cover which could be found need not be very thick. Many of the bullets picked up from the ground appeared to be quite undamaged. Three were found sticking in the canvas screens and appeared to be ricochets."

A week later a further trial of a similar nature was attempted at even longer ranges, this time the firers being fifty picked men from the King's Own Regiment. The canvas targets were placed at a distance of 3,100 yards from the firers and were extremely difficult to see with the naked eye. A strong wind greatly affected the shooting and, besides its considerable effect on the bullets, the screens were blown forwards into a sloping position and presented a very

poor target to the firers. There were only forty-seven actual hits on the targets and it was believed that the majority of the bullets struck the ground between distances of 2,650 and 2,870 yards, ranging power having been greatly affected by the strong head wind. To obtain some information on the effect of bullets at this long distance deal boards, one inch in thickness, were placed flat on the ground in the vicinity of the screens. In every instance where a hit was registered the board had been penetrated. Of the recovered bullets which had failed to reach the screens, two-thirds were from the Lee-Metfords. This was attributed to the Lee-Metford rifles having been in regular use since 1892, the barrels being considerably worn.

CHAPTER V

ACCOMPLISHMENTS OF NEW SMALL ARMS COMMITTEE

IN January, 1900, the Small Arms Committee was completely re-constituted to consist of:

- The Commandant, School of Musketry, Hythe (President).
- The Superintendent, Royal Small Arms Factory, Enfield.
- The Superintendent, Royal Laboratory, Woolwich.
- The Chief Inspector of Small Arms, Enfield.
- The Chief Inspector (Ammunition), Woolwich.
- District Inspector of Musketry, Aldershot.
- The Captain, H.M.S. *Excellent*, or some other Naval officer.
- The Assistant Director-General of Ordnance, to act as Secretary.

It was considered that with this constitution there would be as President an officer in no way committed to any type of manufacture or existing design and with practical experience of rifles in the hands of troops. There would also be represented among the members:

- Manufacture of arms.
- Manufacture of ammunition.
- Inspection of arms.
- Inspection of ammunition.
- Practical experience with troops.
- Naval experience and requirements.

The Secretary of State approved the constitution of this committee on 18th January, 1900, and later in the year an addition was made in a representative of the National Rifle Association.

The first important problem which the new committee had to deal with was the alleged shooting to the right of the Lee-Enfield rifle. With this rifle already issued to British troops engaged in operations in South Africa the problem was of paramount importance. An investigation was immediately commenced into how these inaccurately sighted weapons were accepted for the Services from

the manufacturers. The cause was soon brought to light. It was revealed that the accuracy shooting acceptance tests applied by the Government inspectors to new weapons were of a very cursory nature and there was nothing laid down in the specification to ensure the correct individual sighting of each rifle. All rifles were tested on a sight-testing machine which was dimensionally based on a sealed pattern rifle. The sealed pattern was decided by the following procedure. The average sighting was taken of several weapons which had shot satisfactorily at ranges of 200, 300, 600 and 800 yards. One rifle was then selected whose sighting range approximated to the average figures. If this was found to be satisfactory after further examination it became the sealed pattern to govern manufacture. In the sealed pattern of the Lee-Enfield rifle an allowance had been made for left deviation of the bullet by placing the foresight .05 in. to the left of the axis of the bore and consequently all the rifles of early manufacture embodied this deviation in the sighting system. The foresight was integral with the foresight block which was brazed and screwed on to the barrel and could not be moved to make any corrections after it had been fixed in position. After the backsight had been soldered on, the barrel was placed in the sight-testing machine, when the height and position of the sights, and the graduations on the leaf, were accurately gauged to conform with the sealed pattern. The depth and figure of the "V" notch in the backsight cap and the profile of the barleycorn foresight were also gauged. After the action, with the barrel assembled, had been subjected to certain tests to ensure correctness of pull-off, extraction, functioning of magazine, etc., it was subjected to its only shooting test. This consisted of having five service rounds fired from it, three of which were fed into the chamber from the magazine and the other two with the cut-off in the closed position. There was also a clause in the specification to the effect that 10 per cent of the rifles submitted by the manufacturers could be shot at a target at a range of 500 yards, when a figure of merit (an average distance of all shots from the centre of the group) not exceeding 0.8 ft. had to be obtained. In this test thirteen rounds were fired, the first three being fired from the magazine and were ignored when calculating the figure of merit. A rifle failing to pass the test could be fired a second time before being removed from the rest from which it was tested. In a later specification, for Mark I* rifles, the shooting test was altered to the following: "10 per cent of the rifles may be tested by having ten rounds fired from each at 500 yards, nine at least of these shots must be contained in a circle 2 ft. in diameter." Apart from having to conform to the sight-testing machine, there was nothing in these specifications to ensure that the rifles were correctly sighted for shooting. The 2-ft. circle could have been on any part of the target and the shooting of all accepted rifles could have erred

in one particular direction and, under the specification terms, be passed by the inspectors into the British Services.

Immediate action was taken to rectify the Lee-Enfield rifles in the hands of troops in South Africa, and on 18th January, 1900, it was decided to issue new backsight leaves to replace those on their rifles. In these new leaves the sighting "V"-notch was cut $\cdot 03$ -in. to the left of centre, reducing the allowance for deviation to $\cdot 02$ -in. Consideration was then given to finding the best method of correcting the remaining rifles which had been made, and preventing a recurrence of the defect in future manufacture. To determine the exact amount of error in the sighting, and obtain information on points which might influence the amount of deviation, several trials were held with rifles from the three places of manufacture, these being the Royal Small Arms Factories at Enfield Lock and Sparkbrook, Birmingham, and the B.S.A. Company of Small Heath, Birmingham. A decision was eventually arrived at and on 22nd October, 1900, the method of dealing with the problem was officially approved and announced in the War Office List of Changes as follows:

Method 1 (for future manufacture): Barleycorn foresight to be solid, and to be fixed $\cdot 02$ in. to the left of the axis of the bore.

Method 2 (for rifles sent to Birmingham for repair): A removable barleycorn foresight to be fitted $\cdot 02$ -in. to the left of the axis of the bore and pinned into the foresight block (as in the Lee-Metford, Mark I* rifle).

Rifles dealt with under these two methods were marked with a * on the right side of the foresight block.

Method 3 (for rifles in the hands of troops and in Army stores): The 'V'-notches in the slides and caps of backsights to be $\cdot 03$ in. to the left of centre. Rifles so altered to be marked with a * at the bottom right corner of the face of the leaf."

Later in the year it was found that accuracy was improved by permitting a slight movement between the stock fore-ends and the barrels of rifles and carbines and, on 8th December, a clearance around the barrel of $\cdot 01$ in. was approved for Lee-Enfield and Lee-Metford weapons. The clearance was achieved by enlarging the barrel hole in nose-caps and upper bands by $\cdot 02$ in. and increasing the fore-end band grooves. The enlargement commenced at the lower band in rifles and at the backsight in carbines, and increased until flush with the barrel holes in nose-caps and lower bands.

Shooting to the right was not the only complaint which the Small Arms Committee had to deal with. Alleged undersighting and other inaccuracies of rifles and carbines in the British Army

became subjects of numerous trials and investigations. In February, 1900, a report from the Superintendent of the Royal Small Arms Factory, Enfield, was received with much interest as it threw considerable light on these matters. In the course of experiments with the Lee-Enfield rifle it was found that a slight inaccuracy in the fit of the resisting shoulders of bolt and body affected the direction of the shooting. The toleration allowed at this point was $\cdot 003$ in., and this amount taken off the resisting shoulder on the left side of one rifle, and off the right side of another rifle, gave a difference respectively of 8.19 in. and 8.54 in. on the target. The same bolt was used in both rifles. Further tests confirmed this result and it seemed that the real cause of inaccurate and variable shooting of weapons embodying the Lee action had been discovered. Any uneven bearing of resistance shoulders on bolt and body of rifle tended to alter the direction of the shooting. This could account for the fact that whereas the original Lee-Enfield rifles tested for sighting required a foresight correction of $\cdot 05$ in. it had since been found that an allowance of $\cdot 02$ in. was sufficient. This was the same correction needed for the Lee-Metford rifle, whose action was identical with that of the Lee-Enfield. There was sufficient tolerance allowed on this bearing to account for the variation between rifles made in different factories. The Superintendent considered that if the point were closely watched in manufacture they would get constant shooting from the rifles. The findings at Enfield were confirmed by the Superintendent of the Royal Small Arms Factory, Sparkbrook. He was also aware of the effect of incorrect bearings at the resistance shoulders and considered there were three distinct causes of the unsatisfactory shooting. These he enumerated as follows:

1. The present adjustment of the sight was not so arranged that the bullet would hit the object aimed at for any range. At 500 yards the error on the target was from 18 to 30 in. to the right.
2. The height of impact of the bullet on the target was influenced by the fit of the wooden stock fore-end to the extent of about 3 to 6 in. at a range of 300 yards.
3. The adjustment of the lugs and resisting shoulders in bolt and body had very considerable influence on the lateral accuracy of the shooting.

A trial had been held at Sparkbrook with four Lee-Enfield rifles which had the shoulder bearings correctly adjusted. After 4,000 rounds had been fired through them the bearings were examined and it was found that no change had taken place. The angle of deflection had also remained completely unaltered. Velocities had fallen by about 70 to 110 feet seconds. This was expected as the "lead" (chamber to rifling) had increased from $\cdot 80$ in. to 1.20 in.,



A WARTIME OPPONENT OF THE LEE-ENFIELD
A German 7.92 SERVICE RIFLE fitted with Grenade Thrower.



THE No. 1 MARK 5 RIFLE

Although approved for possible production, the No. 1 Mark 5 Rifle was never adopted for the British Service. It differed from its predecessors in the Lee-Enfield family by being fitted with an aperture backsight. It was produced in limited numbers for troop trials. Its accuracy never reached a very high standard and it was eventually abandoned for a new design which became the No. 1 Mark 6.

RIFLE, SHORT MAGAZINE LEE ENFIELD .303 NO. 1, MK. 3. 19



RIFLE MAGAZINE .303 PATTERN 1914.

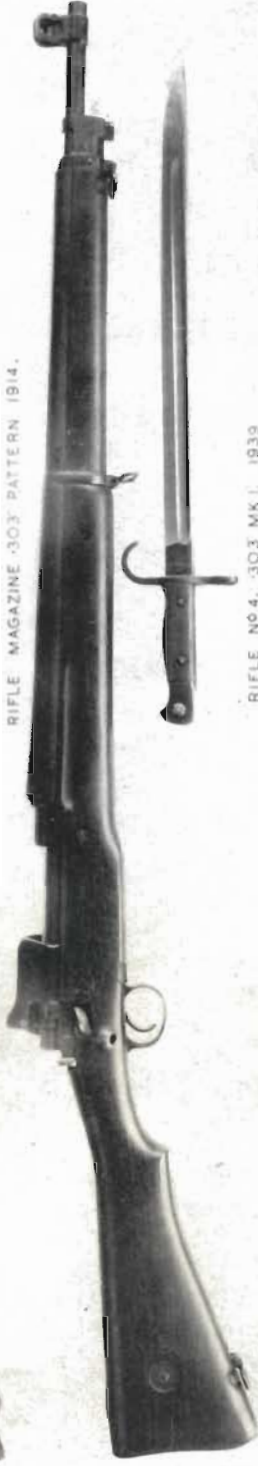

RIFLE NO. 4. .303 MK. I. 1939



Each rifle is shown with its appropriate sword-bayonet. The centre and right-hand bayonets under the No. 4 Rifle are the "spike" bayonets issued during World War II; the bayonet on the left is a post-war issue.

as the bore of each rifle became enlarged through shooting. The trial was considered to have conclusively proved that once the shoulder bearings had been correctly fitted they would not alter.

As a result of this investigation and discovery, a new clause was immediately added to the specification governing the manufacture of Lee-Enfield rifles. This called for "The resistance shoulders on bolt and body to be tested to ensure an even bearing". Other clauses recommended by the Committee concerned the testing of all rifles for accuracy and sighting and included the following:

- "(a) Every rifle to be fired at a range of 35 yards from a table rest. Five rounds to be fired with a full sight, flap and slide down, aim to be taken on a paper target. First shot not to be counted, the other four to be contained in a rectangle $1\frac{1}{2}$ in. broad and 3 in. high; the bottom of the rectangle to be $1\frac{1}{2}$ in. immediately above the point of aim.
- (b) Five per cent of all rifles to be fired at a range of 600 yards. Firing to be done from the table rest and the backsight slide to be adjusted to the 600 yards elevation line. Seven rounds to be fired, of which three of the last five must be inside a horizontal band 4 feet deep. The centre of the band to be at the height of the mean point of impact of a 'standard' rifle fired on the same day, at the same range, by each testing operator. The 'standard' rifle to be fired again should there be any climatic changes likely to affect elevation. A full sight to be taken."

When a rifle did not pass test (a) the foresight was adjusted, or replaced by another, and the test was repeated. If failing a second time the rifle was returned to the factory for rectification. Rifles failing to pass test (b) were returned to the factory for examination, and a further 5 per cent of rifles from the same batch were tested. If a failure occurred in the second selection the whole batch of rifles from which the sample was taken was returned to the factory for examination. The ammunition used for the tests was specially selected and, in the event of several rifle failures as regards elevation, it was tested for velocity in a "standard" rifle. The cartridges had to be kept at a temperature of 60° F., and have a mean observed velocity of 1,960 feet per second at 90 feet. In the event of any fault being found with the ammunition, all tests of rejected rifles had to be repeated. For the purpose of the tests a "standard" rifle was defined as "an accurate shooting rifle as regards elevation, with ammunition giving correct mean velocity". In November, 1900, it was decided to alter the distance for testing rifles from 35 yards to 100 feet. The reason for the change was that it was easier to make comparisons for accuracy or for calculating the equivalent at longer ranges of deviations or errors of sighting. Thus, a $\frac{1}{2}$ -in. error at

100 feet equalled $1\frac{1}{2}$ in. at 100 yards, or 15 in. at 1,000 yards. Also, at 100 feet one minute of angle on the sights equalled (closely) one-third of an inch on the target. The shooting test clause in all specifications was altered accordingly. As the direct result of the many complaints which the Small Arms Committee had received, an important safeguard of correctly sighted rifles for the British Service had now been firmly established.

At the same time it was decided to check up on the methods employed by other countries in testing weapons for accuracy before accepting them for service. It was ascertained that the U.S.A. tested their rifles in the following manner. All rifles were tested for mechanical strength by firing five rounds through each, unaimed, into a butt. No regular percentage was fired for accuracy and the shooting test employed at the Government Arsenal was of a somewhat unusual nature. A permanent squad of about ten very expert marksmen selected from the Arsenal workmen was maintained and, every Saturday, they took about a dozen rifles at random from the current week's output and tested them on the range. No other test for accuracy was made, and it was claimed that this method was extremely satisfactory and kept a sufficient check upon the standard of manufacture. The ranges employed for the shooting were usually 200, 300, 500, 600, 800 and 1,000 yards. All firing was done from the shoulder. The marksmen were seated, with their backs against supports, and the muzzles of their rifles were supported. No precise standard of accuracy was laid down. The decision as to whether a rifle was accurate and fit enough for the U.S. Service was left to the discretion of the marksman who fired it.

From the Continent came reports from Germany, Austria, Switzerland, Denmark, Italy and France, all of whom tested their rifles for accuracy by shooting. The French Government's method was to select five or six rifles every day from the previous day's output, a day's output being about 200 weapons. These were tested for accuracy and direction, followed by an endurance trial in which 1,000 rounds were fired through each rifle. Accuracy firing was from the shoulder by selected marksmen, with weapon supported, at a range of 200 metres. All arms tested had the same sight adjustments and mean points of impact had to be close to the aiming mark. Italy tested 10 per cent of her rifles, which were fired from a rest at 200 yards range. Shots were not allowed to deviate from the centre of the target beyond 8 in. laterally and 10 in. vertically. Germany tested all her rifles at 150 metres, Austria at 100 paces, and Switzerland at 30 metres, using an increased charge.

Some doubt was cast on the ultimate success of accuracy testing at only one distance by the Chief Inspector of Small Arms in a report to the Small Arms Committee. Recent experiments had confirmed that accuracy of sighting at the short testing range was no

guarantee that the sights would be correct for any other distance. Slight differences in stocking up, position of recoil shoulders, etc., made rifles shoot differently and, unless every rifle was individually sighted correctly at the longer ranges, accuracy of sighting would not be obtained. The Chief Inspector also contended that however accurately sighted a rifle was when it left the factory, after a short time in use the sighting would alter for one or more of the following reasons:

1. Settling down of the resistance shoulders.
2. Slight warping of the stock fore-end.
3. Settling down of barrel and action in stock fore-end.
4. Slight injury to sights.
5. Wear of rifling.

The concluding comments in the report were of particular significance. They were: "We have tried, now, many rifles of foreign make which are supposed to be tested for sighting at short range, and not one of them has been correctly sighted for the longer ranges. I think it will be found that it will be absolutely necessary for every man to know the shooting of his rifle and not trust too much to the marks on the backsight."

In June, 1900, the Small Arms Committee recorded their opinion that there were defects in the Lee-Enfield rifle that made it desirable to consider the provision of a new rifle for the British Army. Apart from these defects, trials by foreign Governments had shown that, since the introduction of the Lee-Enfield, many improvements had been devised which could not be adopted without introducing an entirely new rifle. The defects in the Lee-Enfield to which the Committee referred were:

1. It was too complicated.
2. Bolt-heads were liable to damage.
3. The bearings of the lugs on the bolt were such that any unevenness affected the shooting.
4. The striker was not easy to remove for purposes of cleaning and consequently was liable to become clogged by oil. It was cocked by the movement forward of the bolt which was considered to be a serious defect.
5. The magazine was a bad one. It was flimsy, much exposed, and easily damaged. The weapon was not, in the true sense of the word, a magazine rifle.
6. The magazine catch and the trigger being both activated by the same spring was a defect which could not be remedied by alterations.
7. The rifle was needlessly heavy and had too many springs.

The committee were further of the opinion that a decision should be made on the following points:

1. Whether .303 in. was the best calibre for a Service rifle.
2. Whether the principle of a magazine rifle capable of being used as a single loading weapon was desired, or whether it should be a purely magazine rifle.
3. Whether a rifle which loaded automatically was desirable.
4. Whether a rifle with a shorter barrel and longer bayonet was desirable, with a view to one arm being available for all the services.

Meanwhile considerable progress had been made on the Continent in the development of automatic arms. This was watched with considerable interest by the British authorities and eventually an Italian invention was considered worthy of attention. This was known as the CEI "GAS RIFLE" and the following article appeared in *Il Messaggero*, Rome, on 1st May, 1900:

"In 1895 Captain Cei-Rigotti showed the Prince of Naples, who then commanded the Florence Division, an invention of his, by means of which the gas produced by the explosion of each separate cartridge endued the ordinary Military rifle with a rapidity of fire equal to that of the Mitrailleuse. The Ministers of War and of Marine at once turned their attention to this important discovery, and informed Captain Cei to construct rifles and mitrailleuses, which were tried in the Gulf of Spezia, and at the Viareggio range. To tell the truth, Captain Cei paid more attention to the practical trials of his invention than to constructing a definite model, and determined to await the completion of these trials before making the actual rifle to be used by the infantry. In fact it is only now, after five years of constant study, and encountering difficulties of every description, that he has been able to realize his idea of a weapon that will doubtless be the rifle of the future, the dream of those who consider rifle fire the chief element of destruction in future wars. Captain Cei would never listen to the advice constantly offered him to limit the application of gas to increasing the rapidity of fire in mitrailleuses alone; he aimed at solving the problem of a weapon to be used exclusively by infantry, and he succeeded, as he showed at the Conference recently held at Brescia before the whole garrison, where he exhibited a small rifle of the weight and size of a cavalry carbine, capable of firing fifteen rounds per second of the same bullets as are used in the army small-bore rifle, and with the same velocity. With this rifle, the soldier can fire one round at a time, quietly and under fire discipline or, at will, he can fire hundreds of cartridges in two or three minutes, with the certainty of hitting the target as he never need lower the rifle from his shoulder, except to refill the magazine. This is evidently a great

saving in labour as he need not raise and lower the rifle at every round to take fresh aim. The rapidity of fire is obtained entirely by using the gas of each cartridge discharged to move the breech-block and explode the succeeding cartridge. The movement imparted to the cylinder is so rapid as to be imperceptible to the eye, and to propel all the bullets in the magazine one after another with a distance of 45 metres between them and with a muzzle velocity of 700 metres per second. The apparatus is very simple and is composed of four movable parts arranged under the barrel; it is this simplicity which renders its application to an infantry rifle. The rifle is similar in dimensions and weight to the regulation small-bore rifle of the Italian Army, except that the gas apparatus renders it an ounce or two heavier. The breech-block always moves in a straight line but revolves simultaneously on its own centre, so as to block the cartridge in the barrel. The cartridges, which vary in number from six to twenty-five, according as to whether the rifle is to be used by infantry, navy, or in fortresses, are enclosed in a magazine which can be refilled in one movement with reserve packets. By using a lever at one side of the breech the soldier can fire one shot at a time, pulling the trigger at each round, or he can fire all the rounds in the magazine automatically by pulling the trigger once; in this case only a prolonged detonation is heard. The calibre of the rifle is 6.5 mm., and the barrel is of such a thickness that 300 rounds can be fired in succession without interruption. The gas that moves the breech-block escapes from a very small aperture near the breech and acts alternately at each round, first on the handle of the breech-block to turn it, then on the cartridge case, which, being driven backwards, pushes back the cylinder. This completes the movement necessary to eject the empty case and place the next cartridge in position for firing. The Italian metals firm, Glisenti-Bettoni & Co., obtained from Capt. Cei-Rigotti at the beginning of this year the regular concession of the invention. It is Patented throughout Europe and registered for a certain time as a monopoly of Italian manufacture. Although the automatic gas rifle is intended to be used chiefly by infantry, it would be of great use to cavalry, or for the defence of forts and on board ship, and when it may be desirable to bring an intense fire to bear on any field of action. The Transvaal War has shown the proper method of employing mounted infantry by sending them unexpectedly to places at a great distance from the base of operations. Modern armies, seeing that they have recently been provided with new rifles, will hesitate to adopt the automatic rifle immediately for arming the whole of their forces. In order to derive some advantage from this powerful weapon they should arm detachments of fifty men per battalion with it. These, employed at the proper time, would be able in three minutes to fire 15,000 bullets at the enemy, at any distance. It would be advisable to bring these

detachments into action when the enemy is at a short distance. The effect of their fire would be greater, the targets would be bigger and the penetration of the bullets at short distances would cause them to pass through several men." From the foregoing it will be seen that this new invention was expected to have great possibilities and, on 5th March, 1901, Capt. Rigotti visited Enfield where trials with his weapon were arranged by the Small Arms Committee. Capt. Rigotti was only able to bring with him thirty-five rounds of ammunition for his rifle and, in order to utilize this small amount to best demonstrate the capabilities of the new weapon, they were fired at a range of 200 yards as follows:

1. Ten rounds by the inventor, aimed rapid fire, with elbow supported on a table rest. A jam caused a delay of seven or eight seconds, but the whole were fired in nineteen seconds (time of loading not included). The shooting was very imperfect.
2. Ten rounds fired by the Enfield Proofmaster in the same manner. The time taken for nine rounds was seventeen seconds (loading time not included). The shooting was good for such rapid fire.
3. Ten rounds by Proofmaster using table rest, the rifle being set to fire automatically as fast as possible. The whole of the rounds were fired in two seconds. The shooting was very wild, two shots completely missing the 24-ft. target.

There were several jams during the shooting and it was considered that extended trials would be necessary before an opinion could be given by the Small Arms Committee. It was decided to carry out further trials when the necessary ammunition was forthcoming. The records show that there were many delays and promises in connection with the supply of ammunition for further trials, and eventually the project was dropped.

CHAPTER VI

A SHORTENED RIFLE FOR CAVALRY AND INFANTRY

SINCE the early troubles with the Lee-Enfield rifle experiments had been going on with the object of modifying it, or producing a shorter and lighter pattern suitable for both cavalry and infantry. The matter was being considered by the British authorities before the South African war and, as the result of certain recommendations, a small number of modified rifles had been submitted to limited technical trials. These were of two different lightened patterns, one weighing 8 lb. 6 oz., and the other 2 oz. lighter. They were submitted to trials in December, 1900, and favourably reported on for handling and serviceability. Accuracy was not as good as that of the British Service arm. Trial succeeded trial as modifications were embodied or discarded, and probably the most troublesome design feature was that of charger loading, regarded as a necessity in the proposed new rifle.

Towards the end of 1900 a memorandum of considerable interest, from the Superintendent of the Royal Small Arms Factory, Enfield, to the Chief Superintendent of Ordnance Factories, was placed before the Small Arms Committee. It read as follows: "As the adoption and manufacturing of a new rifle for the Army will of necessity involve considerable delay and a large expenditure of money, I have been endeavouring to produce a rifle without departing very greatly from our present arm, remembering that, in many respects, it has stood well the test of service in all parts of the world. It will be so improved as to allow for:

1. Better loading, with a charger.
2. Better sighting arrangements.
3. Weighing less, 8 lb. 6 oz. against 9 lb. 4 oz.

The design which I now put forward could, with the exception of the long hand-guard, be manufactured at once with but slight alterations to our present plant, and at little, if any, extra cost to that of the existing rifle. If, as I believe, this design is a vast improvement on the existing rifle, I would urge the necessity of

coming to a decision on the matter as soon as possible, so that we might manufacture at an early date; and make arrangements for the alteration of existing arms with all or such parts of the improvements as may be thought advisable. The main features of the alterations are:

1. A lighter barrel, i.e. the present barrel turned down, except at the breech end.
2. The fixing of the front sight without brazing, which tends to spoil the steel.
3. To avoid any strain on the barrel, the bayonet is fixed to a special nose-cap on the fore-end, so that the bayonet is 'entirely free' from the barrel, and the end of the barrel is protected from external injury.
4. By a slight addition to the bolt-head and body, the rifle is adapted for loading by charger.
5. A new design of charger, holding five cartridges. This is stamped from a single piece of metal and can be manufactured cheaply.
6. An improved form of spring and platform in the magazine, which allows easy loading of ten cartridges. The cut-off has been slightly improved. The rifle can, as heretofore, be loaded singly or fed from the magazine.
7. Having found that many errors in shooting arose from the barrel being held tightly in the fore-end, and by the nose-cap, the barrel in this rifle is entirely free. Thus the heating of the barrel does not affect the shooting, as often occurs in the Service rifle. A long hand-guard similar to that proposed by the Small Arms Committee has been fitted; this, among other advantages, allows of the freedom above-mentioned.
8. A new backsight has been designed which can be quickly set to any range, and can be altered 100 yards at a time 'without looking at the sights'. I believe this latter arrangement to be a valuable adjunct as the elevation can be increased or decreased 100 yards at a time whilst the soldier is on the move. By inserting a piece of ivory in the knobs which actuate the sliding part, the sight can be easily set, however hot the barrel may have become by continuous firing. Another leaf, with 50 yards movement, is submitted with the rifle as an alternative design.
9. A sliding leaf has been fitted, somewhat similar to a design already approved by the Committee, only stronger and less liable to damage.
10. A slight alteration to the bolt, which allows for the striker being taken out for cleaning purposes, without the aid of tools, has been fitted.

11. A double pull-off, giving an action similar to the 'drag' pull-off employed by certain foreign countries, is fitted. The first pull is about 2 to 2½ lb., the total pull-off being about 5 lb. It is considered that, with the lighter pull-off now advocated, some arrangement of this kind is almost a necessity to prevent accidents, and will probably tend to more accurate shooting.
12. The safety-catch has been left out."

The Superintendent at Enfield was instructed to send this rifle to

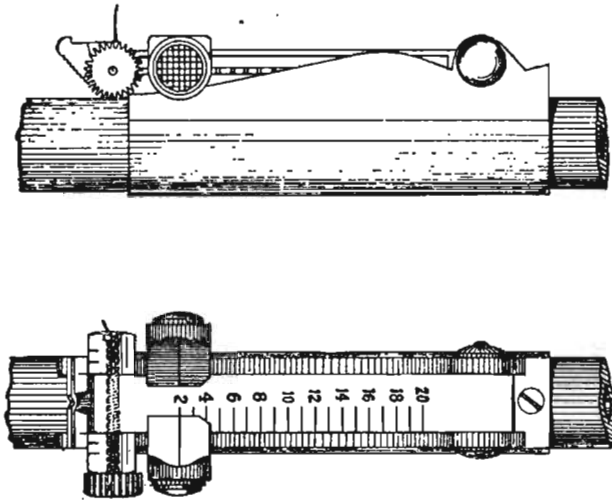

FIG. 8. Pattern A: Backsight on some of the experimental Short Lee-Enfield Rifles.

the School of Musketry at Hythe and, in December, 1900, the Committee decided that it possessed many advantages over the service arm and justified extensive trials by troops. A report to this effect was accordingly sent to the Director-General of Ordnance.

Field-Marshal Lord Roberts was a strong advocate of a rifle with shortened barrel for both infantry and cavalry and he telegraphed from South Africa urging its adoption. The British Cavalry thought they were handicapped by being armed with a carbine and pressed for a longer-barrelled weapon, and it was hoped that the new development would be successful and satisfy all demands. On 12th January, 1901, the Secretary of State approved the manufacture of 1,000 Shortened Modified Enfield Rifles for troop trials, 500 to be fitted with an Enfield experimental backsight (Type "A") and 500 with a backsight approved by the Small Arms Committee (Type "B"). The two patterns are shown in Figs. 8 and 9. Pattern "A" has one "V" sighting notch, at the rear end. Elevation is obtained

by moving the slide along the leaf so that it travels up the curved ramps. The ramps are formed to give equally spaced graduations. The slide is provided with a tooth on either side to engage in notches in the sides of the leaf. The teeth are released by grasping the ends of the slide with the finger and thumb. The bar carrying the "V" can be traversed to give wind allowance (Fig. 8). Pattern "B" is used with the leaf down up to 500 yards and with the leaf vertical for ranges between 500 and 2,000 yards. The slide can be clamped

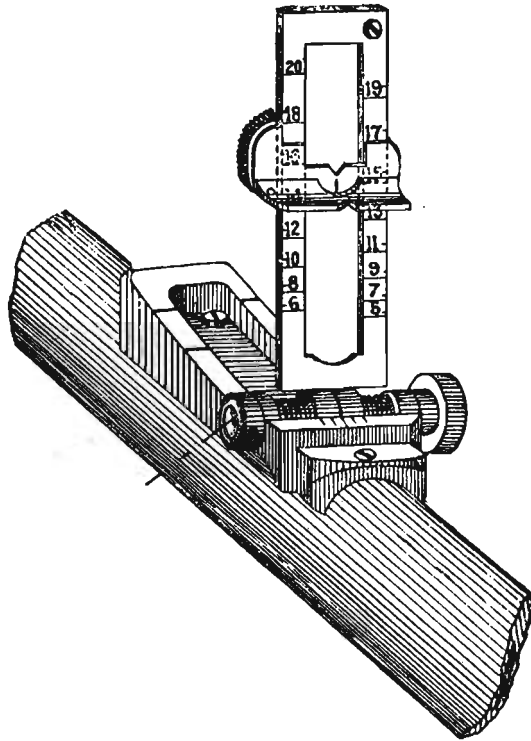

FIG. 9. *Pattern B: Backsight on some of the experimental Short Lee-Enfield Rifles.*

to the side of the leaf in any desired position by a small spring. The entire leaf is traversed to give wind allowance (Fig. 9).

Of particular interest was the form of rifling adopted for this weapon. With the normal Enfield rifling, the Shortened rifle and Service cartridge gave an observed velocity of between 1,920 and 1,940 feet per second; which was considerably lower than with the Service arm, the Magazine Lee-Enfield, Mark I*. A modified form of rifling, which raised the velocity of the Shortened rifle to 2,010–2,030 f.s. was eventually adopted. In this, the rifling was deeper at

the muzzle end than at the breech; and the muzzle end was, for a distance of fourteen inches, bored out one-thousandth of an inch larger than the remainder of the barrel.

In view of the troubles experienced in South Africa from sand and dust, it was decided to fit the trial rifles with magazines which had easily removable platforms and springs. This was to facilitate cleaning. Orders were placed for the trial rifles on the understanding that manufacture would not interfere with, or delay, conversion of existing arms to Enfield rifling. In August, 1902, a further trial took place with twelve Shortened Enfield rifles at Hythe. This was to verify the "sighting curve" of the new rifle and the results largely confirmed the figures arrived at from a previous trial. From these "sighting curve" trials, angles of elevation and sight graduations needed for various distances were calculated. Several other trials had taken place during the year for the purpose of comparing the new Enfield charger loading system with the controlled platform systems of Harris, Ross and Edwards. None of these was considered the equal of the Enfield system and it was decided to wait until after the troop trials with the 1,000 new rifles before organizing further tests.

Fitting Enfield barrels to Lee-Metford rifles made necessary a change in sights and, on 25th February, 1901, War Office instructions were issued for this to be done. The rifles were fitted with backsights in which the "V" sighting notch was 0.03 in. to the left of centre. When barrels were fitted which had a (*) marked on the foresight block (denoting that the foresight was offset) a backsight with a central "V" was fitted. A few months later it was announced in "List of Changes" that Lee-Enfield and Lee-Metford rifles in the hands of troops, fitted with backsights with "V" notches .03 in. to the left, and which had a left shooting error of five inches or more, could be fitted with a backsight leaf in which the "V" was central. On 13th January, 1902, it was decided that when Lee-Metford carbines were fitted with Enfield barrels, and had their nose-cap wings drawn out to the same height as those on Lee-Enfield carbines, they would be called LEE-ENFIELD MARK I CARBINES. The barrels were marked on the Knox-form with the letter "E" to mark the change. Later in the year the sighting was found to need correction, and this was effected by the substitution of new backsight leaves. On these the cap was lower and the slide narrower. The leaf and slide were special to this carbine and the leaf was marked "E.C.88" on the right bottom corner. On 6th September, 1902, further name alterations were announced, consequent on the substitution of Enfield barrels for Metford barrels. It was now decided that when Lee-Metford Mark II* rifles were fitted with Enfield barrels they would become LEE-ENFIELD MARK I RIFLES, if they had the old pattern fore-ends and nose-caps which were grooved

for the clearing rod; and rifles fitted with the newer solid fore-ends and nose-caps became the LEE-ENFIELD MARK I*. The old markings on the bodies were cancelled and the new names stamped on. There were now in the British Service Lee-Enfield Mark I and Mark I* rifles which were either new manufacture or conversions from Lee-Metfords. Certain weapons which were dissimilar in exterior form and sighting such as the Martini-Metford Marks I* and II* Cavalry Carbines and Lee-Metford Mark II rifles retained their old names when fitted with Enfield barrels, though also marked with the letter "E" on the Knox-form.

Weapons to have their names altered when fitted with Enfield barrels were:

The Martini-Metford Artillery Carbine, Mark II, became the Martini-Enfield Artillery Carbine, Mark III.

The Martini-Metford Artillery Carbine, Mark III, became the Martini-Enfield Artillery Carbine, Mark I.

The Martini-Metford Cavalry Carbine, Mark III, became the Martini-Enfield Cavalry Carbine, Mark I.

A persistent trouble with most rifles and carbines in the British Service, especially to those troops operating in hot climates, was the working loose of butts. Consistently hot atmospheres caused the small forward end of the butt, which fitted into the body socket, to shrink. Securing bolts worked loose and, as they could only be reached by an armorer's long screwdriver, butts sometimes dropped off. On 2nd September, 1901, the following modifications were introduced:

1. With a view to preventing shrinkage and working loose of butts, the socket ends were soaked in a preparation of benzole and paraffin wax, and then compressed to size. Butts so treated were marked with the distinguishing letter "P", stamped on the right side near the socket end.
2. To guard against the possibility of stock bolts unscrewing and working loose, they had the ends squared to fit into a square recess in the keeper plate, which was let into the rear face of the stock fore-end.
3. In consequence of the modification to the stock-bolt, the butt had the large hole for the bolt deepened to allow for the squared end of the bolt projecting beyond the inside face of the socket of the body. Stocks and bolts when modified were named No. 2.
4. In order that the soldier should have a rifle or carbine which fitted him correctly, a number of butts $\frac{1}{2}$ in. shorter and some $\frac{1}{2}$ in. longer than the normal butt, were issued. The former were distinguished by a letter "S", and the latter by a letter

“L”, stamped on them $\frac{1}{2}$ in. in front of the tang of the butt plate.

Determining the remaining accuracy life of a worn rifle barrel has always been a difficult problem, and no mathematical formula can provide more than an intelligent forecast. Some barrels, though badly worn, retain a high standard of accuracy long after a less worn barrel has started to throw wide shots. To leave barrels on weapons in the Service until they started to shoot wildly would have been an unwise and impracticable solution. It was therefore decided that the degree of wear, beyond which a barrel might be expected to lose its accuracy, should be the “yardstick” by which its remaining useful life should be measured. This system is in use today. To determine the amount of wear the bore was measured by plug gauges, which were maintained to a high standard of dimensional correctness. The important gauging points of the inside of a barrel are at the muzzle and breech ends, particularly that part of the breech end leading from the chamber into the rifling, and known as the “lead”. On 21st January, 1901, gauging figures were introduced by which barrel life of British Service .303 in. weapons was determined. It was decided that a barrel should be exchanged when it was sufficiently worn to accept the following gauges:

1. The .308-in. plug—entering $\frac{1}{4}$ in. at the muzzle.
2. The .309-in. plug—entering $\frac{1}{4}$ in. at the breech.
3. The “lead” plug—entering $\frac{3}{8}$ in. at the breech.
4. The “lead” plug—entering $\frac{1}{4}$ in. at the breech in conjunction with the .308 in. plug entering $\frac{1}{4}$ in. at the breech.

All small arms in the British Army were checked by these plug gauges on annual inspections by visiting examiners from the Small Arms Inspection Department at Enfield. This service was known throughout the Army as “Travelling View” and for many years it helped to maintain a high standard of weapon efficiency. The examiners were all skilled craftsmen, and they were the authority on whether the weapons they examined were “serviceable” or “un-serviceable”. The examination of barrels was of course only one part of their job. The service fell into abeyance during the Second World War, but was afterwards revived on a three-yearly basis, one-third of the Army’s U.K.-based units being visited each year. Examiners from the Royal Ordnance Factory at Fazackerley, Liverpool, joined Enfield examiners in post-war “Travelling View”. The visits were much welcomed by the Army, efficient unit armourers being in short supply and usually much overworked. Unfortunately for the Army “Travelling View” was abandoned in 1953, presumably for reasons of economy and a valuable link between “inspector” and “user” was lost.

CHAPTER VII

THE TRIAL OF THE THOUSAND RIFLES AND ADOPTION OF THE SHORT MAGAZINE LEE-ENFIELD

THE trial of the 1,000 rifles was probably the most important event in the history of Lee-Enfield rifles as it determined the future design of the British Service arm for many years, including two World Wars. There was much criticism of the proposed new weapon and there were many who felt that British experimental efforts should be concentrated on the development of an automatic arm. The decision to shorten the barrel of the Service rifle was viewed with concern by Bisley target shooting enthusiasts and it was thought that the shorter and lighter barrel and shortened sight base must have a very adverse effect on accuracy. The lighter body and heavier recoil were also disliked, and these features were all subjected to adverse comment in the gun trade journals. The task of the Small Arms Committee was not to please the "trade", or the Bisley marksman, but to produce for both Cavalry and Infantry a reliable charger-loading Service rifle, which would embody most of the good points of its predecessor and omit the bad ones. Whilst accuracy was of paramount importance, it was not to be achieved by any sacrifice of serviceability or lightness.

The programme of the trial was very comprehensive and called for comments on all the main features of the new rifle. It was prefaced by the following instructions: "Every firer will be allotted a Service rifle and a Shortened rifle. Every practice will be executed first with the Shortened rifle and at once afterwards with the Service rifle (or vice versa), in order to secure similar conditions of light, wind and atmosphere. Firers should not be changed during the trial unless unavoidable. All firing trials will be reported on in such detail as may be necessary, but deductions should be embodied under the various sub-heads which apply to them. Although the magazine of the shortened rifle will hold ten cartridges, only five will be loaded into it at one time except as directed for the rapid fire practice at 600 yards. Firers must be trained in charger-loading with dummy cartridges before carrying out trials with rapid fire. The Shortened rifle will be loaded by charger in all trials."

The programme consisted of:

1. Deliberate fire at 200, 500 and 800 yards at second and first class targets respectively. To be fired twice, in any position, seven shots per rifle at each range.
2. Snap-shooting, seven shots per rifle, to be fired twice.
3. Vanishing targets, seven shots per rifle, to be fired twice.
4. Moving targets. Fired twice, seven shots per rifle.
5. Fire at objects large and small, coloured to harmonize with background at varying distances up to extreme range obtainable locally, in bright and dull light and in failing evening light. This trial is intended to afford comparison between the bead and the Service barleycorn foresight; and to test the hood foresight protector.
6. Fire at 2,000 yards at a prepared area of ground or large canvas screens laid horizontally, area not less than 50 yards by 50 yards, fifteen rounds per rifle.
7. Trial with fixed bayonets to test the bayonet fixing and the result (effect) on shooting at 200 yards. Thirty rounds rapid fire; five selected firers; for short rifle only.
8. Rapid fire.
 - (a) For 1½ minutes at 200 yards range.
 - (b) For 3 minutes at 600 yards range.
 - (c) Repeat (b) commencing with a full magazine in the short rifle and re-charging it with ten cartridges.

The trial rifles were sent out to units of the Royal Navy, Royal Marines, Cavalry and Infantry including the Royal Naval School of Gunnery (Sheerness), H.M.S. *Excellent*, the 3rd Bn. The Manchester Regt., 2nd Bn. Highland Light Infantry, 4th Bn. The Middlesex Regt., 21st Lancers, 2nd Bn. The King's (Liverpool) Regt., 4th Bn. The Manchester Regt., 1st Bn. Yorkshire Light Infantry, 4th Bn. Lancashire Fusiliers, 3rd Provisional Hussars, 4th Provisional Dragoons, 10th Provisional Battalion (Shorncliffe), Royal Marine Artillery and the Royal Marine Light Infantry (Plymouth Division), Royal Marine Light Infantry, Chatham and Deal, and the Portsmouth Division; and reports were also requested from General Officers Commanding High Formations, and a Board of Officers assembled at the Curragh. The latter were to report on the results obtained by the 21st Lancers and the 2nd Bn. The King's (Liverpool) Regt. The whole provided a very representative cross section of the British Fighting Services.

The reports that were eventually assessed by the Small Arms Committee were very comprehensive and often conflicting, and it must have taken many hours to build up a balanced overall picture. As was expected the Service rifle, with which the firers were familiar, generally returned the better accuracy figures, but on many other

points opinions strongly favoured the new shortened weapon. In most cases it was felt that with a little more practice in handling and getting accustomed to the new rifle its accuracy would compare favourably with the Service arm. In one instance, the 2nd Bn. The King's (Liverpool) Regt.'s firers were given extra drill in the charging of magazines in order to improve their efficiency before the rapid practice, which included re-charging. The following extracts from the reports illustrate a fair picture of the reactions of the Fighting Services to the new arm:

From the Royal Naval School of Gunnery: "The new rifle was strange to handle, nevertheless it met with approval. The Service rifle held an advantage at every range as regards accuracy and was considered better for aiming at white targets with black bull's-eyes. When firing at khaki-coloured targets against an earth background it was found easier to align the sights of the Short rifle, the white spot on the bead being easily placed on the target. The long hand-guard appeared to protect the barrel well and did away with the mirage caused by a hot barrel in rapid firing. It enabled the rifle to be easily held when it became hot. The hood protector was greatly approved. It shaded the bead foresight satisfactorily, assisted in rapid alignment of the sights, and made unnecessary the use of 'dead black' on the sights. A slot in the crown of the hood was suggested, for the purpose of letting in more light when firing with the sights in the shade. Charger-loading was found to be rapid and easy when loading with five cartridges: loading the second five was not so easy and a great deal of force was found necessary to press them down into the magazine. The bolt was found to be a great improvement on that of the Service rifle as it was easily stripped and assembled. The drag pull-off was considered excellent for an experienced man, but for the inexperienced there was a considered element of danger. It was thought that there would be a tendency to take the first pull when bringing the rifle up to the 'present', leaving only a 2-lb. pull to fire the weapon. The recoil of the new rifle was considered sufficiently severe to be a serious defect and was accentuated when carrying out rapid fire. The general opinion was that as a Service weapon the Shortened pattern was superior to the Service arm, the 'A' type backsight and accuracy of sighting, together with its general handiness, meeting with complete approval."

The Board of Officers at the Curragh reported: "At 200 yards the Service rifle gave slightly the better results but a section of the Liverpool Regt., with the Short rifle and the 'A' type of backsight, made better results than any other section using either rifle. At 500 yards the new rifle made the better average. At this range there was about one degree of wind, and the wind-gauge, used for the first time, was found of great assistance, and probably accounted for the better shooting of the new rifle at this range. At 800 yards

RIFLE. MARTINI HENRY. MK2. 7 GROOVES .45". 1876.



RIFLE. MARTINI ENFIELD. .303 MK1. 1896.



RIFLE "MAGAZINE" LEE ENFIELD. .303" MK1. 1899.



RIFLE SHORT MAGAZINE LEE ENFIELD. .303" MK1. 1904.



MARTINI AND LEE-ENFIELDS

The change from the Martini action to the Lee action in 1899 was the last big change in British Service Rifle action until the recent adoption of the F.N. Automatic Rifle.



THE S.M.L.E. WITH BAYONET FIXED

This is the weapon which won much fame in World War I and proved itself to be one of the most efficient rifles ever to be put into the hands of a fighting soldier. With this rifle and bayonet the incomparable British Army of 1914 fought for its life in the fierce battles around Mons and Le Cateau. It earned the deep affection of many a British soldier.



THE S.M.L.E. WITH GRENADE DISCHARGER

The S.M.L.E. fitted with a Cup Discharger and strengthened for firing grenades.

the new rifle again made better practice than the Service arm, superiority being more marked than at 500 yards. Here it was found necessary to use considerable wind-gauge and the use of the traversing sight was much appreciated by the men of the Liverpool Regt. The results obtained by the 21st Lancers were not so good. They did not seem to appreciate fully the advantage of the wind-gauge, nor were they so well instructed in its use. With both Regiments the 'A' Pattern backsight gave the best results. Loading by charger was considered a great improvement but would be more advantageous if the clip were made to hold the five cartridges more tightly; the end cartridges occasionally fell out. In deliberate firing the method of charging was satisfactory, except for a tendency of cartridges to splay out and overlap. This was more marked in rapid fire and may have been due to the point of the thumb being applied to the cartridges instead of a pressure from the inside of the thumb near the first joint. It was thought that more drill was required for this operation. The long hand-guard was regarded as a long-felt want and the men liked it. After rapid firing of thirty rounds the rifle was easily held. The hood protector was not generally approved by the men, who thought they could aim quicker without it. They considered it did not assist in rapid alignment of the sights, but the Board, and most of the Regimental officers, thought otherwise and approved it. The bead foresight on the new rifle was not liked and the Service type was preferred. The turned-down knob of the new pattern bolt was liked, but the bolt itself was considered more complicated and took longer to strip and assemble than the Service pattern. The new safety-catch was simple and effective and the men soon got used to it, and the drag pull-off was considered superior to that of the Service rifle and approved for all classes of shooting. The difference in recoil of the two rifles was not thought appreciable, if the weapons were properly held. The men who fired most rounds did not complain of any recoil. The removable magazine platform was considered to have done its work well and without any hitch. The absence of a cut-off prevented the rifle being used as a single-loader and at the same time have a fully-charged magazine for emergencies, but the rapidity with which the magazine could be charged outweighed this disadvantage". One of the men of the Liverpool Regt. made a "possible" with the new rifle and, when questioned by the Board on his method of sighting, said he placed the whole of the bead foresight on the bull's-eye, practically obliterating it, and not as he had been instructed to aim, i.e. with the bull's-eye aligned on top of the bead.

The Dragoons considered the Short rifle immeasurably superior to the carbine but not so good as the Lee-Enfield rifle; they thought it might be as accurate in the hands of a scientific shot. The Yorkshire Light Infantry believed that, with more experience of its

peculiarities, they would find the Short rifle superior to the Service arm, especially at the longer ranges. Most units were strongly in favour of the long hand-guard fitted to the new rifle and it was regarded as a long-felt want. It provided great protection for the firer's hands during rapid firing, when the exposed barrel of the Service rifle often became too hot to hold, it prevented mirage, and enabled the firer to maintain a better grip of his weapon. Only the Dragoons considered it of no advantage. Several units experienced trouble with charger-loading, but their adverse comments were levelled at the chargers themselves and not at the system, which was a very popular feature of the new weapon. The hood foresight protector seemed to be a mixed blessing. Whereas it protected the bead from damage and helped definition in bright lights, it interfered with rapidity of aim and with foresight definition in fading lights. With a few exceptions, the accuracy of the sighting of the new rifle was praised, but on the merits of the bead foresight there was a division of opinion. There appeared to be a slight preference for the bead for deliberate shooting and the barleycorn for snap-shooting and rapid fire. The new bolt mechanism had good reports both on general working and ease of stripping and assembling, and the safety-catch had a majority vote in its favour. A man in the Manchester Regt. was reported to have fired a round by means of the safety-catch, but it had been found impossible to reproduce this remarkable accident. The double (drag) pull-off was universally liked for deliberate shooting but there was some opposition to it for rapid firing, generally considered due to unfamiliarity. One feature of the new rifle most disliked was the increased recoil, although this dislike was not universal. Reports from the Royal Marines gave widely divergent views on this point. The Royal Marine Artillery considered the recoil to be excessive, especially at ranges over 600 yards, where the face was often bruised as well as the shoulder. Rapid firing was delayed by the firer taking time to ensure that his rifle was close against his shoulder. This was considered sufficient to condemn the rifle as unserviceable. The Royal Marine Light Infantry at Chatham had different views and thought recoil was no more noticeable than with the Service rifle. The R.M.L.I. at Deal considered there was no perceptible difference between the two rifles, but the Portsmouth Division's report disagreed with this. The G.O.C. South-Eastern District considered the new rifle a great improvement on the Service pattern and its shortness and lighter weight were much appreciated. With bayonet fixed it was very handy, and much better balanced than the Service rifle. The G.O.C. 1st Army Corps suggested further trials with regard to the hood foresight protector, the wind-gauge, position of backsight, and charger-loading. He considered it a question whether the advantage gained by less weight was balanced by increased

recoil and loss of length of rifle. For the Cavalry the rifle appeared excellent, being so greatly superior to the carbine. He was not sure whether the Short rifle would be overbalanced by the long bayonet.

From the foregoing reports it will be seen that the Short Rifle was well received by the Service units taking part in the trial and the new features embodied in the weapon were generally approved. As some of the units were armed with Lee-Enfield rifles, some with Lee-Metford rifles, and some with Carbines, comparisons which were made with the new shortened weapon could not always have been easy to assess. The Small Arms Committee had no easy task but were not long in coming to a decision. On 10th November, 1902, they recommended the adoption of the new rifle for the British Services, at the same time advising the following modifications:

1. A barleycorn foresight to replace the bead, and suggested that further trials should be carried out with the bead and other types of foresight which could easily be substituted without making any other alteration to the rifle.
2. The foresight protector in its present form was not recommended. Suggested that fifty rifles, fitted with barleycorn sights and protectors which had the tops of the hoods cut off, should be re-issued to Cavalry regiments for further comparative trials with fifty rifles fitted with barleycorn foresights and hoods as used in the troop trials.
3. The pattern of adjustable foresight was not approved owing to its ease of removal. It was suggested that further consideration be given to the old system of fixed foresights removable only by armourers, with additional interchangeable foresights of different heights.
4. Tighter chargers for charger-loading, and magazines increased in depth to better accommodate ten cartridges.

The wind-gauge with fine adjustment, the long pattern hand-guard and double pull-off were approved, and a few other minor modifications were recommended. Increased recoil was considered to be unimportant.

On 15th December, 1902, the Superintendent, R.S.A.F., Enfield, submitted to the Committee a Short Rifle differing from the pattern used in the trials in the following particulars:

1. An adjustable barleycorn foresight was fitted.
2. The top of the hood was cut off, leaving the foresight protector in the form of incurving wings.
3. The pattern "A" backsight was fitted to give a long sight radius. It embodied a thicker leaf and more pronounced ivory knobs.
4. The wind-gauge was omitted.

5. An adjusting screw was fitted to the elevation slide.
6. The magazine case was deeper, providing better accommodation for ten cartridges.
7. The charger guides were tightened, making the chargers a better fit.
8. The body was modified to allow for fitting a cut-off, if needed.
9. A thin steel butt-plate was fitted.
10. A lower band was fitted.
11. The butt and nose-cap sling swivel fittings were altered.
12. A new form of stocking-up was employed.

The Committee approved the modified rifle and it was eventually recommended for manufacture.

THE SHORT MAGAZINE LEE-ENFIELD RIFLE, MARK I

On 23rd December, 1902, the SHORT MAGAZINE LEE-ENFIELD RIFLE was introduced in the British Service as a weapon for both Infantry and Cavalry. It was $1\frac{1}{2}$ lb. lighter than the Enfield rifle it superseded, and the general particulars of the new arm were as follows:

Weight of rifle (with empty magazine)	8 lb. $2\frac{1}{2}$ oz.
Length of rifle..	3 ft. $8\frac{2}{8}$ in.
" " (with Patt. 1903 sword bayonet)	4 ft. $8\frac{11}{16}$ in.
" sword bayonet	1 ft. $4\frac{7}{8}$ in.
" " " blade	1 ft. $\frac{1}{8}$ in.
Weight of " "	1 lb. $\frac{1}{2}$ oz.
" " " scabbard	$4\frac{1}{2}$ oz.
" rifle with bayonet	9 lb. 3 oz.

Barrel:

Length	2 ft. $1\frac{3}{16}$ in.
Calibre303 in.
Rifling	.. Enfield, spiral—left-handed,	1 turn in 10 in.
Number of grooves	Five
Depth " " at muzzle0065 in.
" " " at breech005 in.
" " " (to within 14 in. of muzzle)	
Width of lands0936 in.

Sighting system:

Radial backsight and adjustable barleycorn foresight.	
Sight base (distance between backsight "V" and foresight) 1 ft. $7\frac{5}{32}$ in.

The bayonet was attached to a bar and stud on the nose-cap, and not on nose-cap and barrel as on Lee-Enfield and Lee-Metford rifles.

The Pattern 1888 bayonet, by fitting a new pommel, was also corrected to fit the rifle.

The barrel was similar in external diameter, but slightly smaller, and five inches shorter than that of the Lee-Enfield. It was fitted with a band to carry the foresight block and was strongly reinforced at the breech end. The block was keyed and pinned to the barrel and had a dovetailed slot to carry an adjustable barleycorn foresight.

The magazine held ten rounds and was filled by means of chargers, each carrying five cartridges. Guides for the chargers were provided on the bolt-head and body, that on the bolt-head being in correct position when the bolt was fully withdrawn. The charger was held in the guides whilst the five rounds were pressed down into the magazine.

The foresight was a "barleycorn" which could be moved in the dovetailed slot in the block to its correct position for sighting. It was made in three heights, High, Low and Normal, each differing by .015 in. These enabled the rifles to be adjusted for correct elevation before they were issued to the troops.

Backsight. The backsight was fitted with a leaf pivoted to the bed at the front end. At the rear end of the leaf was a cap in which a "V" notch was cut. It was through this "V" notch that the firer aligned his foresight on the mark at which he aimed. Elevation was effected by moving the slide, which was assembled round the leaf, and rested on curved ramps on each side of the backsight bed. The curves were the result of careful calculations based on the results of shooting trials at various distances. The leaf was graduated by lines indicating every 100 yards of elevation from 200 to 2,000 yards, the even numbers being marked by figures. The slide could be set at any elevation, or at any intermediate 50 yards. It was securely held in position by means of catches engaging in notches on each side of the leaf. When re-setting the slide the catches were disengaged by pressing the bone studs on each side of the slide. The cap was joined to the leaf by a vertical dovetail. It could be given a fine adjustment for intermediate ranges, between the 50-yard intervals afforded by the slide, by means of a vertical adjusting screw underneath the cap. A small vernier scale, divided to give a vertical movement of .0106 in., was provided on the left edge of the cap and leaf. Each division on the vernier represented 2 in. of elevation per 100 yards. The slide at its highest gave an elevation for a distance of 2,050 yards. The dial sight for long ranges was graduated from 1,600 to 2,800 yards, and was identical with the one fitted to the Lee-Enfield. The following particulars give the principal differences between the Short Rifle and the Lee-Enfield, which has been described in Chapter III:

Body. The body was made with the charger-guide on the left to receive the charger by which the magazine was loaded. It had a stop on the right, which forced the charger-guide on the bolt-head

forward when the bolt was fully drawn back. A hole was bored through the left side of the body near the rear for the safety-catch, and below it another hole for the stem of the locking bolt. A slot was left for the purpose of assembling a cut-off, in case one was re-introduced for the Army. A cut-off was supplied for the Naval Service only. The left side of the body was cut away to afford a clearance for the thumb of the right hand when pressing cartridges from the charger into the magazine.

Barrel. The grooves of the rifling were the same shape as in the Lee-Enfield barrel but increased in depth towards the muzzle. It gave the same velocity as the longer Enfield barrel.

The bolt. The bolt rib was lower and the bolt handle was set closer to the body. The bolt was shorter as the extension for a safety-catch (no longer required for this purpose) was cut off. As there was no bolt cover, the projections and groove for this were omitted.

Bolt-head. The bolt-head was fitted with a charger-guide which worked upon the top surface of the projection for the extractor. When the bolt was drawn back, the rear end of the charger-guide struck against a projection on the resistance shoulder of the body, and was pushed forward into such a position that the groove for the charger was opposite the groove in the charger-guide on the body. The charger was then inserted and firmly held whilst the cartridges were being pressed into the magazine. A slot was cut in the threaded end of the bolt-head, which acted as a key when stripping and assembling the striker and cocking-piece.

Cocking-piece. The cocking-piece was shorter. The projections for the safety-catch were omitted, and also the hollow sleeve which fitted over the rear end of the Lee-Enfield bolt. It had two recesses in the left side for the locking-bolt to engage in. The striker-keeper screw was replaced by a nut. This was screwed on to a screw, round the shank of which was a spiral spring contained in a recess in the cocking-piece. This striker-keeper nut could be pulled to the rear and slightly turned by the thumb; the striker could then be unscrewed from the cocking-piece after unscrewing the bolt-head. The bolt could be completely stripped without the aid of tools.

Trigger. Two ribs, or nibs, were embodied on the upper part of the trigger. On the trigger being pressed, these nibs bore successively on the lower arm of the sear and produced a double pull-off. The weight of the first pull was 3 to 4 lb. and the second 5 to 6 lb. The pull-off weight was adjusted by altering the angles of the mating faces of sear and cocking-piece, the angle being increased to reduce the weight and reduced to increase the weight.

Magazine. The magazine was about $\frac{1}{2}$ in. deeper than that for the Lee-Enfield and contained ten cartridges in two columns. The depth was increased to facilitate loading the second five cartridges by

charger. The magazine platform was fitted with a zigzag spring, and an auxiliary spring which hooked on to the front end of the magazine case and kept the front end of the platform at the proper angle when the magazine was full of cartridges. The magazine had a stop clip on its right side to keep the right-hand cartridge in position, and to enable the platform and spring to be easily removed for purposes of cleaning. On the back of the magazine was a tooth cut in a rib which, when the magazine was pressed upwards through the trigger-guard opening, engaged in the tooth of the magazine catch. The catch was pivoted under the body and was pressed forward by the sear spring. To remove the magazine from the rifle, the end of the catch was pressed backwards and upwards.

Inner band. An inner band, which encircled the barrel at the centre with a clearance of $\cdot 002$ in., was fitted inside the stock fore-end. It was held in position by a screw, spiral spring and washer, so that it was supported without being held rigidly. This allowed any possible expansion of the barrel.

Outer band. An outer band encircled the stock fore-end and hand-guard over the inner band. It was jointed at the top, and held together by a screw underneath, which also carried the sling swivel. The swivel screws for butt, band and nose-cap were interchangeable.

Nose-cap. The nose-cap was considerably larger than that of the Lee-Enfield rifle and the front end was flush with the muzzle of the barrel. It had an extension, in front of which the cross-piece of the sword bayonet was fitted, and a bar underneath held the pommel of the bayonet. It was provided with lugs to carry a swivel and screw, and had protecting wings for the foresight. The barrel was allowed $\cdot 002$ in. freedom in the barrel hole.

Swivels. There were two swivels, one attached to the outer band and one to the stock butt. The latter swivel could be attached to the lug on the nose-cap, allowing mounted soldiers to sling the rifle on their back. For the Naval Service only, a piling swivel was attached in this position.

Hand-guard. The hand-guard completely covered the top half of the barrel, extending from the body to the nose-cap. It was in two pieces, divided vertically at the centre of the backsight bed. The front portion was held in position by the outer band with its front end fitting into a recess in the nose-cap. The rear portion was held in position by a spring. This was riveted to the hand-guard and clipped on to the barrel near the breech end. Both the hand-guards rested on the shoulders of the stock fore-end and were quite clear of the barrel throughout their length. The rear hand-guard was fitted with a steel backsight protector which had two upstanding ears roughened on top to prevent reflection of light. It protected the cap of the backsight from injury and consequent maladjustment of sighting. In stripping the rifle it was necessary to remove

the rear hand-guard first, the front hand-guard could then be pushed back clear of the nose-cap, after the outer band had been taken off.

Stock fore-end. The stock fore-end extended to within $\frac{1}{2}$ in. of the muzzle of the barrel. It was tight fitting round the body, but the barrel was free in the barrel groove throughout its length excepting $\frac{1}{2}$ in. in front and rear of the inner band, and under the Knox-form at the breech end. The fore-end was fitted with a keeper-plate which was let into its rear face, and into which the squared end of the stem of the stock-bolt fitted. This prevented the bolt from turning and the stock butt from becoming loose.

Stock butt. The stock butt was issued in three lengths. One was $\frac{1}{2}$ -in. shorter and one was $\frac{1}{2}$ -in. longer than the normal butt. These were marked with the letters "S" and "L" respectively. The butt was fitted with a sheet-steel butt-plate. The oil bottle and pullthrough were not housed in the butt which was bored with four longitudinal holes for lightness, and had a brass marking disc screwed into the right side. The stock-bolt was shorter and was squared at the front end to fit into the keeper-plate. In stripping the rifle, the fore-end had to be removed before the stock-bolt could be turned.

Butt-plate. The sheet-steel butt-plate was lighter; the butt trap pin, spring, spring screw, strap and strap screw being omitted.

Safety. The safety-catch and locking bolt were situated on the left side of the body and were held in position by the long range aperture sight spring. The locking bolt was provided with a stem which fitted into a hole in the left of the body leading into the groove for the cocking-piece. The end of the stem was cut to semi-circular section and, when the thumb-piece was in the forward position, the cocking-piece passed over the cut-away end of the stem. When the thumb-piece was in the rear position, the solid portion of the end of the stem engaged in either the back or front recess in the cocking-piece, according to whether it was in the fired or cocked position, and locked it securely. When the stem engaged in the recess, the cocking-piece was slightly withdrawn. The safety-catch was formed with a stem which fitted in a hole in the left side of the body. At right-angles to the outer end of this stem was a flat arm, the bottom of which worked on the threads of the locking bolt. When the thumb-piece was in the forward position, the end of the stem was in the hole in the body and, when the thumb-piece was turned over to the rear the threads, acting on the end of the arm, forced the safety-catch inwards. At the same time, the end of the stem entered the short groove in the rear end of the bolt and prevented it from being rotated and drawn back.

Charger. The charger was made of steel and oil-blackened, and had holes in the back and sides for lightness. It held five cartridges.

Bayonet. The Pattern 1903 sword bayonet was similar to that fitted

to the Lee-Enfield rifle, except that the slot at the side of the pommel was on the same side of the handle as the ring on the cross-piece.

Stocking-up. The method of stocking-up the Short rifle was as follows: The barrel was held down firmly at the reinforce by the front trigger-guard screw. To limit the amount of crush on the wood when the screw was tightened, a collar was fitted to the screw. The collar was adjusted for length as considered necessary to prevent the wood being too crushed up and, at the same time, ensure the barrel being a close fit on the fore-end. It was very important that this screw be kept tightly adjusted as any looseness could also affect the pull-off of the rifle. The trigger being mounted on the trigger-guard, any looseness could affect the relative positions of the trigger and sear. The fore-end was a close fit on the body and barrel to the position of the backsight. From backsight to muzzle the barrel groove in the stock fore-end was opened out, the muzzle being free in the groove. The barrel groove was deepened and did not touch the barrel from the reinforce to within $\frac{1}{2}$ in. of the lower band. From the lower band the bottom of the barrel groove was flush with the barrel hole in the nose-cap. Behind the nose-cap the fore-end was recessed at the bottom of the barrel groove to house a stud and spring, which controlled the relative positions of barrel and fore-end.

A few months after the introduction of the Short rifle, a wind-gauge was added to the backsight, and certain rivets in the hand-guard and sight protector were replaced by screws. These additions necessitated a cancellation of the rifle's introduction paragraph in the List of Changes, and the weapon was re-introduced on 14th September, 1903.

CHAPTER VIII

MOSTLY TRIALS AND EXPERIMENTS

FOLLOWING the adoption of the Short Magazine Lee-Enfield Rifle for the British Service came a period of "taking stock". Would the Short rifle fulfil all requirements, or would it be short-lived like its immediate predecessor? In the next few years much was done in test and trial to find the answer to this question. Whilst the big troop trials were proceeding in Home Commands, a number of rifles had been issued to British troops in Somaliland with the object of gaining some information as to the suitability of the shortened weapon for service in a sandy country. The report forthcoming from the Somaliland Field Forces, who had carried out various trials, contained the following complaints:

1. *Bolt action.* The absence of a bolt cover allowed sand and grit to get into the mechanism. Despite constant cleaning, this became clogged and choked and it was often very difficult to operate the bolt.
2. The absence of a *cut-off* was considered to be a serious defect in bush fighting, especially where native troops were concerned. It was found necessary to use the rifle practically as a single loader only, in the interests of safety.
3. Butts worked loose.
4. The projecting heads of striker keeper-screws often broke off. It was considered that they should be flush with the rear face of the bolt.

In assessing this report the Committee considered it necessary to bear in mind the fact that the new rifle had been put in the hands of troops who had had no previous training with the weapon. The principle of loading involved a cardinal departure from previous methods. It was therefore not surprising that, when a body of men were supplied with a rifle which varied in material respects from that to which they were accustomed, they should experience difficulties which were more apparent than real. With regard to the need for a cut-off, it did not appear to be appreciated that the

safety-catch fulfilled the same functions in a multiple-loading weapon as the cut-off had done in the Lee-Enfield. The Committee did not believe that a bolt cover could have been of any real value as a protection against the sand effects in such a country as Somaliland; the only effective safeguard was systematic and frequent rifle inspections, combined with the necessary instructions against exposure to sand and dust. Drastic experiments at the Hythe School of Musketry had conclusively proved that any clogging of the action by sand could be soon remedied. Tests had been carried out with rifles oiled to an undue extent and covered with sand. They were subsequently placed in an oven, raised to a temperature far higher than that of any tropical country, and left for twelve hours. When functioned, the bolts at first worked stiffly but, after brushing off the sand by hand, the mechanism soon worked smoothly. Actually the new rifle had been found more immune from jamming by sand than any Continental rifle. Further very comprehensive tests were carried out with the shortened rifle to test its efficiency under sand conditions, after which the Committee were completely satisfied that there was no real requirement for a bolt-cover. The soldier must be fully instructed to carefully remove by hand any sand or mud observed on the bolt and, if necessary, remove the bolt for purposes of cleaning. The big troop trials had disclosed no troubles of this nature but, should any real difficulties arise in the future, the Committee considered that a bolt-cover could be easily fitted.

During the year 1902, considerable research work was carried out in attempting to discover the cause of "wild" shots experienced on service and in trials with the Service rifle, and more recently with the new Short rifle. Often a proportion of shots with some rifles failed to conform with the general pattern of a group, without necessarily being very wide of the mean point of impact. The cause, or causes, of these inaccuracies was obscure and investigations had not been revealing. A large number of variables concerned with manufacturing tolerances on both weapon and cartridge had to be considered, and the cause of the trouble could have been a combination of a few or all of them, and the trouble could not be produced at will. Variables affecting the problem included:

1. *In the barrel.* High and low diameter of the bore, with possibly high or low depths of grooves in each. High and low limits on the "lead".
2. *In the bullet.* High and low diameter, high and low weight, and high and low length. There was also a variation in the degree of hardness of the cupro-nickel envelope.
3. *In the charge.* High and low weight, and high and low power in imparting velocity.

4. *In the case.* Variation in air space. The admissible extent of this was not laid down in the specification as it could not well be controlled. It was considered to exist as the result of variables in the length and diameter, exterior and interior, of the case. High and low diameter and length.
5. *In the cap.* Variation in weight and charge. Hardness and thickness of metal of shell. Variations in the power of the explosive used.

In addition to these variables there were an infinite number between the "high" and "low" limit variations. The problem facing the investigators was of a very complex nature. The first suggestions to be made were two alterations to the barrel. These were (a) Cutting the muzzle so that the end had a perfectly square face and (b) Reducing the length of the "lead". With existing barrels, it was suggested that just as the bullet was leaving the muzzle its direction was upset by an uneven escape of gas round its base, and it was badly supported as it was being forced into the rifling. It was further considered that, in addition to a shortened lead, a slight alteration to the front of the cartridge-case would further help to support the bullet. It was decided to carry out trials to test these points, and special stores used for the purpose included:

1. Special cartridges with different designs of bullet, and some with cases slightly chamfered at the mouth to suit special barrels with a shortened "lead".
2. Special Long and Short Lee-Enfield barrels manufactured to "high", "low" and "mean" bore diameters, some having modified "leads" and some with the muzzles cut square.

Some interesting, though not always conclusive, facts emerged from the trials. It was found that:

1. Bullets to the high diameter (.312-in.) gave better results than those made to the low limit (.310-in.).
2. Barrels made to the low limit of bore diameter shot better than those to the high diameter limit.
3. At the 600-yards range an outstanding feature was the remarkably good shooting of those rifles embodying the special "lead" and square-faced muzzle. Their figures of merit were twice as good as those of the normal Lee-Enfield rifles and much better than that of six Mannlicher rifles which were included in the trials for purposes of comparison.
4. At the 100-foot range the shooting results were often exactly the reverse of those at 600 yards. In most cases where a rifle shot better than another at 100 feet, the result was reversed at 600 yards.

It was suggested that an explanation of the conflicting results at 100 feet and 600 yards was that when gas pressure at the muzzle was low, the blast did not deflect the bullet much to one side. When the bullet was blown to one side it would make a bad diagram at 100 feet, but the gyroscopic action produced by the extremely rapid rotation of the bullet would keep its axis parallel to its original course. Air resistance would quickly destroy the sideway motion of the bullet and force it to travel in the direction of its axis. Thus the error at 100 feet did not increase with the range. The normal Lee-Enfield barrel, with its long "lead", offered less initial resistance to the bullet entering the bore than the barrels of the Short rifles or those with the special "lead", hence the initial pressure was lower. As the normal barrels were also five inches longer, their muzzle pressures were considered to be decidedly lower. At 1,000 yards the Short rifles, with barrel bores to the low limit, shot better than the Long rifles with similar bores. This confirmed the shooting at 600 yards. As a result of the trials, the general conclusion was that the cause of bad shooting had been overcome by the special short "lead". The improvement was considered to be due to the bullet being properly supported by the "lead" and accurately centred on being driven into the bore.

The special "lead" was eventually incorporated in the Short Lee-Enfield barrels, but this did not end inaccuracy troubles. In May, 1904, the Chief Inspector of Small Arms reported that he was having considerable difficulty in passing S.M.L.E. rifles through their accuracy acceptance shooting tests. With a considerable proportion of the rifles being manufactured, he was getting wide grouping at 100 feet and, to a lesser degree, comparatively at 600 yards; the wide shots in the groups usually making badly-shaped holes on the target. After the first shot, subsequent shots showed a tendency to register across the target to the right or to the left, or vertically up and down. A probable cause of the wide grouping was considered to be the enlarged bore in the last 14 in. of the barrel. The bullet, having been forced into a diameter of .3025 in., or .303 in., at the breech, did not expand to the full depth of the rifling at the muzzle, and consequently lost steadiness in flight.

The Superintendent of the Royal Small Arms Factory, Enfield, reported on the investigation and experiments which he had carried out on this matter. The 1,000 rifles which had been made for the troop trials all had barrels with a bore diameter as nearly as possible to .303 in., and were lapped out to .304 in. for 14 in. from the muzzle end; the grooves being tapered as laid down in the specification. When deciding on the manufacturing tolerances of the Short rifle, the bore tolerance laid down was similar to that for the Long rifle, i.e. ± 0.02 in. The breech could be .3025 in. to .3045 in., and the muzzle .304 in. to .306 in. It was this combination that was

considered to be the cause of bad shooting. Recovered bullets showed that they had not expanded in the grooves beyond $\cdot 3155$ in. The groove toleration at the muzzle was $\cdot 3155$ in. accepting and $\cdot 3205$ in. rejecting. With this large diameter the bullet was loose in the grooves. It was considered that this would not have been harmful if the lands had supported the bullet, but they did not do so when the breech was to the low diameter and the muzzle to the high. The consequence was that the bullet was apt to leave the bore when not properly centred, and give sideways hits on the target. The Superintendent suggested that the remedy was to leave the grooves as they were, giving the desired extra velocity and, he believed, lessening the barrel vibrations, and making the bore parallel throughout. The velocity lost by doing away with the lapping would be small, and manufacture would be simplified. It was in the lapping process that the mischief often crept in, and accuracy was often impaired by bell-mouthing the muzzles.

The Small Arms Committee agreed that the bore, but not the grooves, should be made parallel throughout, and this method was eventually adopted. In 1917 the tapered grooves were superseded by parallel rifling.

Another interesting trial was carried out with the object of ascertaining the static force necessary to push a bullet of mean diameter ($\cdot 311$ in.) through a barrel of $\cdot 303$ -in. diameter. It was found that the necessary force varied from 4 to $4\frac{3}{4}$ tons per square inch with bullets lubricated in the Service manner, and from $5\frac{3}{4}$ to $7\frac{3}{4}$ tons when not lubricated. (Note: Service manner means lightly oiled.) This gave an indication of the important part played by friction, even allowing for some easement from expansion when the bullet was fired in the normal way. In these experiments the bullet was pushed through the barrel by means of a rod. In further limited trials with fully greased bullets it was found that accuracy was improved although velocities tended to be irregular. This discrepancy between accuracy and velocities had been noticed before and raised a doubt as to the correctness of the method used for taking velocities. Somewhat different results were obtained in another trial. In this a number of rounds were fired through a barrel which was wiped through with an oily rag between each round, and a number fired through a barrel which was kept dry throughout the trial. The mean observed velocity obtained from the lubricated barrel was 1,934 feet per second, and from the dry barrel 1,932 f.s., a difference of only 2 f.s. Whilst these velocities were being taken, the oiled barrel shot 3 in. higher at 180 ft. and 6 ft. higher at 600 yards. The difference of 2 f.s. could not have accounted for even a fraction of these differences but, if trifling variations in velocity were indications of considerable variations in friction in a barrel, this friction may have set up barrel vibrations which affected the

shooting to a marked extent. This theory was considered by the Small Arms Committee.

Further experiments were carried out to obtain information on the connection between velocity, pressure and accuracy of .303-in. ammunition. The rifles used for these experiments were a new Magazine Lee-Enfield Mark I* from run-of-work, and a new Short Magazine Lee-Enfield. The former embodied the .8-in. "lead", the normal "lead" for Enfield rifling in which the bullet fitted loosely, and the S.M.L.E. had a modified .3-in. "lead", in which the bullet was a fairly close fit. The Magazine Lee-Enfield was fired at 180 feet for velocity, with the following lots of ammunition:

1st lot.	3	warming shots.
2nd "	10	rounds, with dry cases.
3rd "	5	" the cases having been dipped in Rangoon oil and allowed to dry for two hours.
4th "	5	" the cases dipped in Rangoon oil and allowed to drain for about one minute.
5th "	5	" the cases dipped in Rangoon oil and rounds immediately placed in chamber of rifle.
6th "	5	" cases dry, with ring of mineral jelly $\frac{1}{8}$ in. broad and about $\frac{3}{8}$ in. thick round the bullet at the mouth of the case.
7th "	5	" cases dry, with ring of mineral jelly $\frac{1}{2}$ in. broad and about $\frac{3}{8}$ in. thick round the bullet at mouth of case.

The S.M.L.E. then fired the same number of rounds which had been treated in a similar manner. The resulting velocities were:

Lot Number	M.L.E., Mark I*	Increase in velocity above Lot No. 2	S.M.L.E.	Increase in velocity above Lot No. 2
Lot 2	1,994 f.s.	—	1,969 f.s.	—
Lot 3	2,002 "	8 f.s.	1,991 "	22 f.s.
Lot 4	2,016 "	22 "	2,018 "	49 "
Lot 5	2,036 "	42 "	2,039 "	70 "
Lot 6	1,996 "	2 "	1,998 "	29 "
Lot 7	2,085 "	91 "	2,047 "	78 "

The theory that was considered to fit the above results was that the oil on the cartridge case was, on the round being fired, squeezed out by the expansion of the case from between the walls of the case and the chamber into the space between the "lead" and the bullet, before the latter had moved to any considerable extent. The oil more or less filled up the space between the "lead" and the bullet,

according to the amount on the cartridge case. Therefore the escape of gas was checked by the oil before the "lead" was sealed by the bullet. The initial movement of the bullet was checked, as the bullet could not "set up" into the "lead" until the oil was squeezed out from between "lead" and bullet by the latter expanding, through shock of explosion. This check to the bullet enabled the cordite to be more completely consumed, and the sealing of the "lead" by the oil retained the gas; hence the extra pressure and velocity. The oil from the cartridge cases in Lots 3, 4 and 5 gave a much greater increase in velocity over Lot 2 when fired from the S.M.L.E. This was considered to be due to the smaller space between "lead" and bullet than in the other rifle; the sealing of the "lead" and check to the bullet being more complete. The same explanation was applied to Lot 6. With Lot 7 the result was reversed; here the amount of mineral jelly was sufficient to completely fill the space between "lead" and bullet in either rifle, the escape of gas being completely sealed and the bullet checked as much as possible. No accuracy trials were carried out in connection with these experiments.

Early in 1903, trials were commenced to determine the graduations on the long distance dial sight plates for ranges of 2,300, 2,700 and 2,900 yards, and to ascertain at what range it would be possible to shoot taking an aim over the backsight leaf when it was raised to a perpendicular position. The extreme range available at Hythe was 2,500 yards, and arrangements were therefore made for shooting at the longer distances to be carried out at Lydd. The exposed situation of the Lydd ranges, and the prevalence of high winds, caused much delay. It was thought advisable to commence the trials at the longest ranges and a start was made at 2,900 yards. Several attempts were made under favourable conditions to obtain with the long range sights the required elevation for this distance, but without success. The bullets were observed to fall 100 to 150 yards short, even when assisted by a following wind. With extreme elevation of sights, shooting was then commenced at 2,800 yards range. Two seven-round groups were attempted with each of the twelve rifles used, but only two or three shots reached the target. These were obtained with two rifles which were subsequently found to give correct elevation at a distance of 2,790 yards with the sights at the maximum setting of 2,800 yards. The distance was then reduced by successive advances of 10 yards each, until hits were obtained with each rifle. When the correct extreme range was found, two groups were fired from each rifle. It was found that the extreme range at which the long range sights could be used was for two rifles 2,790 yards, for eight rifles 2,780 yards, and for the remaining two 2,760 yards. In taking an aim over the top of the raised backsight, the correct range was found to be 2,800 yards.



THE FIRST TANGENT LEAF BACKSIGHT TO BE APPROVED FOR THE BRITISH ARMY

The tangent leaf aperture backsight fitted to the No. 1 Mark 5 Rifle. Approved but never adopted it marked a major change in the sighting of the British Service Rifle, and set the pattern of what was to follow. The sight is shown in position for firing.

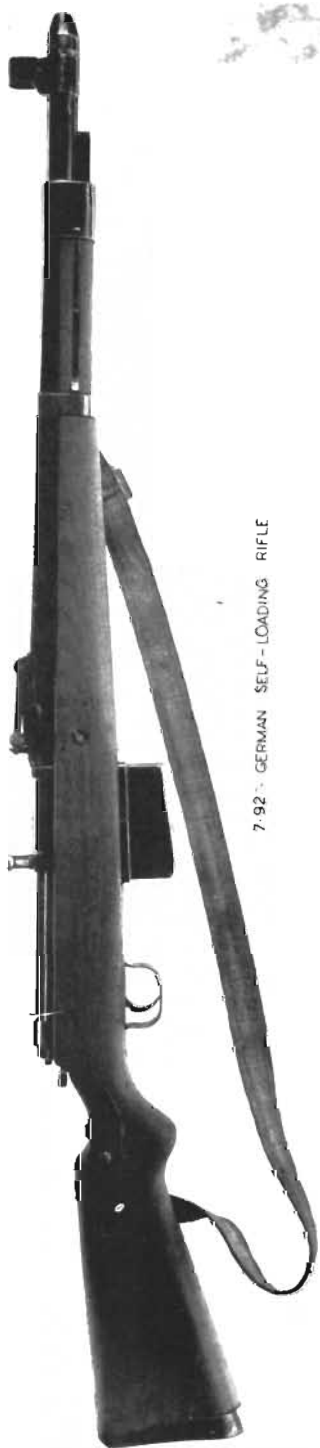

7.92 GERMAN SELF-LOADING RIFLE

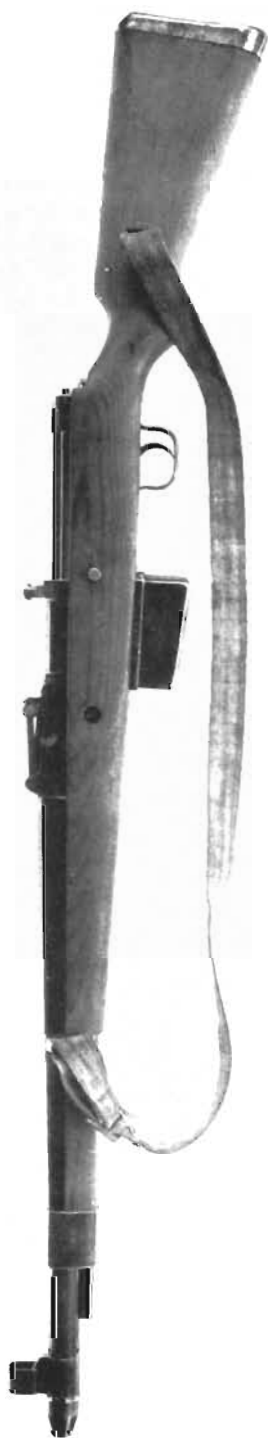

7.92 GERMAN SELF-LOADING RIFLE

A WORLD WAR II OPPONENT OF THE No. 4 RIFLE
The standard German Infantry arm of the Second World War, the 7.92 mm. self-loading rifle.

At this distance, with R.L. Cordite Mark II ammunition (M.V., 1,960 f.s.) which was used throughout the trial, the standard of shooting was considered to be very good. The Committee considered it was not necessary to have the rifle sighted beyond this distance.

On 19th March, 1903, the Chief Inspector of Small Arms submitted to the War Office his report of examination of the 1,000 Short rifles returned to Enfield after the troop trials. The most serious defect found in these weapons was in the safety-locking device. Eighty failed to lock the bolt and were found to be badly fitted and overstrained; this was considered to be due to the safety-catch being applied when the bolt-lever was not properly down. The bolt-locking safety-catch was considered to be the weakest feature of the rifle. If the point was too hard it was liable to break, if too soft it was liable to be cut away by the stud in the groove of the bolt. From the loss of rifle bolts in South Africa, it was evident that one of the most important factors in a safety-catch was that it should not be liable to be unintentionally knocked out of the safe position. The safety-catch of the first Short rifles did not thoroughly satisfy this condition. Twenty-six striker keeper-screws were broken and eleven were lost. Seventeen magazine auxiliary springs were deficient and thirty detached from their cases. Twenty-two stock fore-ends were split and many rivets and washers lost. Of the barrels, 753 were found to be slightly eroded and worn, seven were cut inside, but only three had slight metallic fouling. In view of the hard trial to which the weapons had been submitted, the damages could not be considered excessive.

A number of conversions from various patterns of Lee-Enfield and Lee-Metford rifles were scheduled to take place in 1903, and consisted of fitting the shorter and lighter Enfield barrels and new sights, and adapting the weapons to loading by charger. On 16th January the SHORT MAGAZINE LEE-ENFIELD (CONVERTED) MARK II was introduced. This was a conversion from Lee-Enfield rifles Marks I and (later) I*, and Lee-Metford rifles Marks II and II*, and the principal other features of the conversion were:

The body was altered to receive the Short rifle magazine and the safety device, and was adapted to loading the magazine by charger.

The bolt had the cover lugs and the extension for safety-catch on the rear end removed. The striker hole was bushed. With Lee-Metford rifles only the cover lugs had to be removed.

The bolt-head was altered to receive the charger-guide. It also had a slot cut in the screwed end, which acted as a key for stripping and assembling the striker and cocking-piece.

The trigger-guard had a slot cut in the back to lighten it, and was freed at the front to clear the stop clip of the magazine.

The stock fore-end had a liner fitted and glued in position. The swivel

slot and lower band pin hole were filled in and the fore-end reduced externally. An extra stop pin was fitted to the outer band.

The stock butt was reduced externally, and bored longitudinally with four holes for lightness. The stock bolt hole was deepened. A recess was cut at the socket end to clear the locking bolt, and the recess for the butt-plate strap was filled in. The butt was fitted with a marking disc. The butt-plate was made of sheet metal and the trap for an oil bottle (not now carried) was omitted. When the stock butt was small at the socket end the shoulders were cut back. This shortened the converted rifle, as compared with the new S.M.L.E., by about $\frac{1}{4}$ in. The rifle was fitted to take the Pattern 1903 sword bayonet on the nose-cap.

The barrel and sights were identical with those fitted to the Short Lee-Enfield and, with a few minor exceptions, components were interchangeable. On 12th August, at the request of the Royal Navy, a cut-off was approved for this rifle, and also for the S.M.L.E. Mark I, but only for the use of the British Naval Service. The cut-off was a new pattern and differed from that fitted to the Long Lee-Enfield in that a space was cut near the joint to clear the magazine stop clip and the left edge was turned up to facilitate manipulation. On 2nd November another conversion was introduced. Details of the conversion were similar to those just described and, in this instance, the Lee-*Metford* Mark I* was to become the **SHORT MAGAZINE LEE-ENFIELD (CONVERTED) MARK I**. Although officially approved for the British Service, this conversion never went into manufacture, and nearly three years later it was declared "Obsolete". Two other British military weapons had minor name changes during 1903. Consequent on the fitting of an adjustable barleycorn foresight, the *Martini-Enfield Rifle*, Mark I, became the **MARK I***, and the *Mark II* became the **MARK II***.

A new cartridge was introduced to the British Service on 29th January, 1904. This was the **CORDITE .303-in. S.A. BALL CARTRIDGE, MARK VI**. It was similar to the *Mark II* but differed in the distribution of metal in the cupro-nickel bullet envelope, and in the bullet itself. The nose of the bullet was rounded and the envelope was slightly thinner at this section. Details of the new cartridge were as follows:

The case was solid drawn brass with formed cap chamber, solid anvil and two fire-holes. It was not lacquered, and the letter "C", denoting cordite, contractor's initials, and mark of cartridge were stamped on the base.

The cap was of copper and contained a charge of .6 grains of cap composition. It was varnished, and usually covered with a tin foil disc.

The charge consisted of 30 to $32\frac{1}{2}$ grains of size $3\frac{3}{4}$ (Mark I) cordite—60 strands.

The wad was a glazeboard disc placed on top of the cordite.

The bullet was round-nosed and weighed about 215 grains, and the core was 98 per cent lead and 2 per cent antimony. The envelope was 80 per cent copper and 20 per cent nickel, and contained no iron. The length of the bullet was 1.255 in. (the Mark II bullet was 1.25 in.) and the contractor's initials or trade mark were stamped on the base.

Velocity at 90 feet was 1,970 (plus or minus 30) feet per second.

Pressure was 17.5 tons to the square inch.

Accuracy "Figure of Merit" was 8 in. at 500 yards.

The length of the cartridge was 3.037 in. (the Mark II was 3.05 in.).

Considerable progress had now been made in the development of cordite and it had been established that, by reducing the amount of nitro-glycerine in relation to the amount of guncotton, the excessive erosion it caused in rifle barrels was overcome. The modified cordite which was adopted was called Cordite M.D. and its composition was as follows:

Nitro-glycerine	30 per cent
Guncotton	65 „
Mineral jelly	5 „

Compared with Mark I cordite, it was harder and more brittle and was slower burning. The temperatures of explosion and the pressures developed were considerably lower, and consequent erosion of the barrel was considerably less. It was rather more difficult to ignite and, owing to the hardness of the material preventing the escape of any substances causing deterioration, did not keep so well as Mark I. When pressed into tubular form, to increase its burning surfaces, it was called Cordite M.D.T. In this form it was more suitable for small arms ammunition. On 11th May, 1905, four types of cordite were officially approved as propellant charges. They were CORDITE, CORDITE M.D., CORDITE T., and CORDITE M.D.T. At the same time it was announced that the various sizes of cordite, other than tubular, would be distinguished by a number. The number would represent in hundredths of an inch the diameter of the die through which the cordite had been pressed. The size of tubular cordite would be represented by two numbers, recording in hundredths of an inch the mean external and internal diameters of the finished cordite, e.g. 5-2. The normal length of cordite sticks, or tubes, would be shown in the details appended to the designation. Where any particular size was made to more than one length, the length would be included as part of the primary designation.

CHAPTER IX

LORD KITCHENER REPORTS

IN 1905, in response to a questionnaire from the War Office, a very comprehensive report on the special features of the Short Rifle was received from the Commander-in-Chief of the British Forces in India, Lord Kitchener. The reaction of the user was sought on the following points:

1. Do the protector wings shut out too much light from the foresight?
2. Is the barleycorn satisfactory as to shape and adjustability?
3. Is the "V" backsight notch the best shape and size to suit the barleycorn?
4. Is the wind-gauge advantageous for field service purposes?
5. Is a fine adjustment on the backsight necessary?
6. Is the long hand-guard necessary?
7. Is the safety-catch necessary?
8. Is the drag (double) pull-off preferred to the dead pull?
9. Does the charger-loading meet requirements?
10. Does the slight increase in recoil affect shooting?
11. Is the rifle considered superior to the Long Rifle in handiness, accuracy, and general utility?
12. Is the rifle preferred for snap-shooting?
13. Is the decrease in weight considered important as regards marches, etc., and lessening fatigue to firer in continuous fire?
14. Does the rifle fairly sustain accuracy after considerable use?

Reports were called for from all regiments that had been issued with the Short Lee-Enfield, and from Schools of Musketry, in India. Most of the units had only recently been re-armed with the Short rifle and only a comparatively few squadrons of cavalry and companies of infantry had had much experience with the new weapon. The hot season had prevented any comparative trials on the march, or at long distance or continuous firing, with the Long and Short rifles, and the latter had not been in the possession of the troops

long enough for an opinion to be formed as to their retention of accuracy after considerable use. Based on the reports sent to him from the various units and schools, and on his own experience and that of his staff, Lord Kitchener's answers to the questionnaire are quoted in full, as follows:

“1. The foresight wings are not a disadvantage. They thoroughly protect the foresight, and so a bead or a much sharper barleycorn might be used. They do of course darken the foresight on a dull day, but on the other hand they shade it on a very bright day and when the browning on the foresight has been worn off, and this appears a great point in their favour, especially in India, where one never goes on to a range without seeing soldiers trying to darken their sights with the use of a match. It was noticed that many Commanding Officers said the wings were a drawback in snap-shooting. The real fact was that the man had not got used to them. In snap-shooting, or in shooting in the dusk, it was generally impossible to properly align the sights on a small objective, and in such cases the foresight wings were particularly useful, and allowed a fairly accurate aim to be taken between them.

2. As far as is known, no foresights had required adjustment. The barleycorn was too blunt, and a sharper sight such as is generally found on the Mauser, and other foreign arms, would be more suitable. This, however, is very much a matter of individual opinion, the main consideration is that the foresight should stand the wear and tear of service, and the provision of foresight wings ensured that; and allowed of a finer sight being used than had formerly been the case.

3. There seemed to be no doubt that the “V” of the backsight is too narrow at the top, especially with the blunt foresight; it should be wider as in most sporting rifles.

4. The wind-gauge is not necessary for field service but, at the same time, is not disadvantageous. There may be occasions when it may be useful in the hands of highly trained marksmen. It is argued that soldiers in the heat and excitement of action might unintentionally shift the wind-gauge, or after using it forget to re-adjust it, and so waste their fire. The same argument might equally be used against the provision of the slide on the backsight. The use of the slide and the wind-gauge is a matter of training and discipline. Men can be taught the use of the wind-gauge as easily as the use of the slide, and even if some of them are too stupid to learn it, as was hinted by one Commanding Officer (though I do not agree that this is the case), there is no reason to deprive more intelligent soldiers of its use. The wind-gauge has, at any rate, the advantage of showing the soldier what can be done with the rifle when furnished with such an appliance, and makes him take a greater

interest in the power of the rifle, and it is thus a valuable adjunct for training purposes.

5. The same remarks apply to the fine adjustment.

6. The long hand-guard is absolutely necessary. One of the defects of the Long rifle was that it had no hand-guard in front of the backsight. No man after ten or fifteen rounds rapid firing could hold his rifle, and to use the bayonet or mount a horse with the rifle in the hands after rapid fire was almost impossible. The long hand-guard also prevents mirage rising between the sights from a heated barrel. The mirage that rises from the wood of the hand-guard, if saturated with oil, is much less than that from a heated barrel. The only defect in the long hand-guard is that it is not sufficiently secured to the rifle at the backsight.

7. The pattern of safety-catch on the Long rifle is preferable to that on the Short Lee-Enfield. That on the Short rifle is too narrow and too close to the body of the rifle, so that unless it works absolutely easily a man with a large clumsy thumb, or a thumb numbed with cold, cannot use it. Its close proximity to the aperture sight is a disadvantage.

8. The drag pull, when the troops are used to it, will be acknowledged superior to the dead pull.

9. There are complaints that cartridges do not slide easily enough into the magazine, and do not always lie there correctly. There were only a few chargers to each regiment, and this disqualification will probably disappear with use and practice. One charger full (five rounds) is all that can be got comfortably into a magazine at a time, and there is some difficulty in forcing in the second charger full. There does not seem to be any necessity for the magazine to hold more than five rounds, as is the case with many foreign arms. To insert a charger full after expenditure of five rounds is the work of less than a second, and if the magazine is made for five rounds only it will hardly protrude below the body of the rifle. Arms could then be carried at the slope or trail without coming in the way of the shoulder or hand, as the present awkward magazine does.

10. Men have got so used to the practical absence of recoil with the Long rifle that they naturally noticed the increase with the Short rifle, especially in snap-shooting; in which they have got used to firing without pressing the rifle into the shoulder. This will soon wear off, and the increase of recoil will not affect the training of recruits. After firing a few rounds the increase of recoil is hardly noticed.

11. For Cavalry the Short rifle is found much superior in handiness and general utility to the Long rifle, and for short, thickset men like the Gurkhas it is also excellent. It will be most popular with the Pioneers, who have to march with all their tools on them. The Long rifle was sufficiently handy and useful for the infantry,

but it was thought that the Short rifle will be generally preferred. As regards accuracy, there have been complaints about the accuracy of every pattern of long rifle and carbine that have been received but, owing no doubt to the greater care that has been taken in sighting, there have been fewer complaints against the Short rifle than has ever been known. It must be remembered that rifles are sighted under the following conditions:

- (a) Firing point and objective on the same level.
- (b) A barometric pressure of 30 in. (sea-level).
- (c) A temperature of 60° F.

Troops have to fight and practise in all sorts of localities and on all sorts of ranges, some dead level and others varying in slope, and in all sorts of temperatures. It often happens that officers do not understand these conditions. They are published in the Indian Musketry Regulations, but many instances have occurred of British Regiments located in the hills, at 6,000 feet above sea-level, complaining that their rifles were over-sighted. I am satisfied that the sighting of the Short rifle is as accurate as it can be made.

12. The small 'V' in the backsight is a disadvantage in snap-shooting. The drag pull-off and slight increase in recoil made some people think that the rifle is not as good for snap-shooting as the Long rifle, but these objections will disappear as the men become accustomed to the new weapon. The Short rifle is much handier but seems a little overweighted at the muzzle. There is no doubt that the shortness of the barrel is a great help to rapid firing from behind cover, and men can use it effectively without undue exposure.

13. As already stated, we have had no opportunities of judging as regards fatigue, but it follows that the lighter rifle (by about 1 lb.) must be easier to carry and manipulate in continuous firing, especially as it is easier to fire it from natural rests.

In addition to the points in the questionnaire, the following require attention:

(a) A cut-off is considered necessary. . . . The rifle is very dangerous at present. In spite of the most careful training in the use of the safety-catch, accidents must always be possible, and loss of life from want of a cut-off would be most deplorable.

(b) The oil-bottle and pullthrough should be carried in a trap in the butt, as in the Long rifle. There can then be no mistake about them always being at hand, and they would not get lost as they do from a pouch.

(c) A bolt-cover is necessary to keep out dirt, sand, etc., and there seems no reason why one should not be made that will not interfere with the projecting charger-guides.

(d) The suggestion, made by the C.O. of the 3rd Hussars, that a

number of rifles should be made with left-handed action to suit men who shoot from the left shoulder, is worth consideration.

(e) The most serious defect of the rifle issued in India appears to be the poor quality of the metal from which many of the components are made. The 1st Bn. H.L.I. have already had eighty striker keeper-nuts broken, and many similar defects have been brought to notice. Defective parts will be got rid of and rifles made serviceable, but results would be very serious if the defects were not discovered and made good before the rifles are taken on service. One rather unusual comment came from the School of Musketry at Punjab. It was that the report and concussion from the new rifle were much louder and more distressing to the ear than had ever been noticed before. Some men found it so trying that they had to stuff up their ears with paper, or anything available. It was considered that these circumstances would tell very materially on the men if fire was maintained, and could not fail to put men off. The 9th Division's report contained the following statement: 'The accuracy of the Short rifle when tried with the Long rifle compares more favourably at long ranges than at short ones. This is due to the closer fitting "lead" of the Short rifle, which centres the bullet better as the cartridge lies in the chamber. Consequently the bullet is better centred when it is driven into the bore, and it flies more truly along the normal trajectory pertaining to its angle of departure. This, at long ranges, counterbalances the fact that its angle of departure is rather more variable than that of the Long rifle, on account of the thinner barrel of the Short rifle being more subject to vibration.' This emanated from an officer who had been previously employed in a technical capacity at the Royal Small Arms Factory at Enfield Lock."

There can be no doubt that this very comprehensive report from India was studied with much interest by the Technical Staff at the War Office and, within a few months of its receipt, the cut-off and butt accommodation for pullthrough and oil bottle returned to the British Service rifle.

During March, April and May, 1905, comparative trials of Long and Short rifles were carried out at the Small Arms School, Hythe. The arms prepared for the trials were:

- (a) Twelve Short rifles of the latest pattern.
- (b) Twelve Long Lee-Enfield rifles of the pattern still in the British Service.
- (c) Twelve Long Lee-Enfield rifles fitted with the Short rifle sights and adapted for charger-loading.
- (d) Twelve Long Lee-Enfield rifles fitted with barrels of the Short rifle type and adapted for charger-loading.

The object of the trials was to compare velocity, accuracy, systems of sighting and speed of loading of each pattern rifle; and compare the physical strain imposed on the firers in continuous firing, and after marching a considerable distance. Ammunition of the same batch of manufacture was used throughout.

1. Velocities were taken at Enfield before and after the trials.
2. Ten-shot accuracy diagrams were shot from each rifle at 500, 1,000 and 1,500 yds.
3. Snap-shooting tests were carried out at moving and vanishing targets, and deliberate and rapid fire at falling iron targets.

The Long rifles fitted with the Short rifle barrels produced the best accuracy diagrams at each distance, the Short rifles being the worst. The discrepancy between all rifles was small, and confirmed the results of earlier trials. In testing the systems of sighting at snap-shooting the Short rifle proved superior from the standing position at vanishing and moving targets. From the lying position, the Long rifle fitted with the Short rifle sights gave slightly the best results. At the falling targets, and in falling light, the hood protector and coarse foresight of the Short rifle made sight alignment difficult and results were detrimental to the weapon. In summing up, it was considered that, as regards accuracy with the existing cartridge, the Short rifle was slightly inferior to the rifles with the longer and heavier barrels. It appeared also that the short "lead" and deepened grooves of the barrels fitted to the Class "D" rifles improved their shooting qualities. Inconsistency of grouping of the Short rifle was thought to have been due to unsatisfactory stocking-up, to the propellant charge not suiting the weapon, to the barrel being too light, or to a combination of some or all of these factors. The firers were all in agreement that the Short rifle was handier and better suited to snap-shooting but not so accurate nor consistent in grouping. They considered the shorter sight-base objectionable, and also the mirage emanating from both front and backsights which was attributable to the barrel being elsewhere encased in wood. Exception was also taken to the hood foresight protector.

Owing to the various alterations and additions made to the Short Lee-Enfield rifles, Mark I and Converted Mark II, since their introduction to the British Service, it was found necessary to have a new pattern sealed to govern manufacture. This was done on 2nd July, 1906, and it embodied the following alterations and additions:

Foresight. Five different heights of barleycorn foresights were now issued according to requirements, enabling shooting variations to be corrected. They were marked on the top left side .93, .945, .96, .975 and .99 respectively, representing in inches their respective heights from the axis of the barrel.

Backsight. The top edge of the wind-gauge had been hardened to prevent damage. The rear end of the sight leaf had been bored to receive two spiral springs which tensioned the fine adjustment, and a new fine adjustment screw was fitted. This had a larger finer milled head, fitted with a tension spring to prevent the screw jarring loose during firing. The new pattern was issued after existing stocks of fine adjustment screws were used up.

Hand-guards. The ends of the two hand-guards, where they met, were cut vertically, and the rear hand-guard was fitted with a double spring clip. The springs were fixed by two longer rivets, placed in a central position lengthwise in the spring. Hand-guards with single springs were replaced by those with double springs.

Trigger-guards. The trigger-guard was provided with a lug to carry the sling swivel and screw, the magazine link loop being removed. The new trigger-guards were fitted by unit armourers, the old ones being returned to store.

Magazine link. This was omitted.

Stock bolt keeper-plate. A new form of plate was fitted, and the recess at the rear end of the stock fore-end was altered to receive it.

Cocking-piece. A stronger striker keeper-screw and nut were fitted.

Magazine platform spring. A retaining nib, raised on the top bend of the spring, prevented movement of the platform on the spring.

Stock fore-end. This was recessed to receive a stud and spring to centre the barrel in the nose-cap. It was also recessed for stock bolt keeper-plate with the higher locking sides, and for the double spring of the hand-guard. Fore-ends fitted with the new stud and spring were marked with the letter "S" below the nose-cap. A screwed pin replaced the rivet and two washers in the fore-end.

Swivels. New swivels, $\frac{1}{8}$ in. shorter than the original ones, were fitted to all rifles in the Land Service.

Piling swivel. This was fitted on the nose-cap for rifles which were not for issue to the Cavalry.

On 2nd July, 1906, the SHORT MAGAZINE LEE-ENFIELD RIFLE, MARK I*, was introduced for the British Service, and it differed from the Mark I in the following particulars:

1. *The butt-plate* was made of gunmetal and was fitted with a trap for insertion into the butt of an oil bottle and pullthrough.
2. *The stock-butt* was recessed for a small bracket to carry the sling swivel. The division between the two lightening holes was removed to accommodate the pullthrough. A leather wad on top of the stock bolt acted as a buffer for the oil bottle.
3. *The magazine case* was deeper at the front to facilitate loading. It was fitted with an auxiliary spring which had a straight end instead of a curved one. Case and spring were marked with the figure "2" for identification.

4. *Swivel screws* were bored longitudinally at the threaded end for expansion by centre-punching. This prevented them from working loose.
5. *The striker keeper-screw head* was slotted so that it could be turned by a coin, to facilitate stripping and assembling.

These modifications increased the weight of the rifle to 8 lb. 7 oz., making it $4\frac{1}{2}$ oz. heavier than the Mark I.

On the same day as the new rifle was introduced, a new conversion was recorded. This applied to Long Lee-Enfield rifles, Marks I and I*, and Lee-Metford rifles, Marks II and II*, and brought these weapons into line with the Short Lee-Enfield Converted Mark II, already described. The new weapon became the **SHORT MAGAZINE LEE-ENFIELD RIFLE CONVERTED MARK II***, and it differed from the **CONVERTED MARK II** in the following details:

The stock butt was recessed for the sling swivel bracket, and the division between the two lightening holes was removed to accommodate the pullthrough. The Lee-Metford butt-plate was retained and the butt marking disc was omitted.

The magazine case was the No. 2 pattern with deeper front end to facilitate loading. An auxiliary spring with straight instead of curved end was fitted.

Swivel screws modified for centre-punching, and *keeper-screws* embodying a coin-slot were fitted.

(For full details of the weapon see Appendix "C".)

On 17th August, 1906, the coin-slotted striker keeper-screw was approved for all Marks of Short Lee-Enfield rifles and, on 25th October the cut-off returned and was fitted to all Short Lee-Enfields in the British Army. The request from the troops in India and Somaliland had at last been satisfied.

CHAPTER X

THE MARK III S.M.L.E. AND MARK VII CARTRIDGE ARE INTRODUCED; AND PROVED IN BATTLE

SINCE the introduction of the Short rifle into the British Service, many experimental trials had taken place at Enfield and Hythe with a view to improving accuracy, functioning of the magazine, loading by charger, and removing other causes of adverse comment. Some of the trials have already been described and, in 1906, experiments were made with modified forms of Enfield rifling. Some consideration was given to a suggestion that the edges of lands and grooves should be made more sloping. It was thought that the edges of the grooves of Enfield rifling were so sharp that the bullet never really got into them, and they were never really cleaned. The objection to the proposed new form was that it was partly a reversion to the old Metford segmental rifling. At the same time experiments were proceeding with a modified cordite propellant and a new pointed bullet and, as the introduction of a new cartridge appeared to be imminent, it was not considered advisable to come to any decision on modified rifling until the new round was established.

Progress was made, however, with charger-loading. The sliding charger-guide fitted to the bolt-head had never been considered a sound piece of mechanism. It had been the best way out of difficulty when, following the experiences of the South African campaign, there was an insistent demand for charger-loading to be embodied in the British Service rifle. It was sectionally weak and liable to wear too quickly on service. At Enfield the Chief Inspector of Small Arms had achieved considerable success with an experimental charger-guide fixed to the left side of the rifle body, which disposed of the sliding guide on the bolt-head. Eventually it was recommended for trial at the Small Arms School, Hythe, and was embodied in a number of rifles with a view to testing especially ease of loading, and strength. At this time consideration was being given to the introduction of a new Mark of Short rifle which would embody a new charger-loading system and the following modifications were already approved by the Small Arms Committee:

- (a) A backsight embodying a "U" instead of a "V" sighting notch.
- (b) A straight-edged blade foresight instead of a barleycorn.
- (c) A nose-cap with modified foresight protectors.
- (d) A butt-plate with trap to oil bottle and pullthrough housing in the stock butt.

Eventually six modified Short rifles were sent to Aldershot for further trials and, on 31st October, 1906, they were reported to be satisfactory.

On 26th January, 1907, the various modifications having been finalized, the SHORT MAGAZINE LEE-ENFIELD RIFLE, MARK III, was approved for the British Service and the pattern sealed to guide manufacture. It differed from the Marks I and I* in the following particulars:

The body was fitted with a bridge charger-guide. The slots for the charger stops were sloped in front so that if a charger was left in the guides after the cartridges had been pressed into the magazine the act of closing the bolt ejected the empty charger.

The bolt-head had no charger-guide, and the slide for it was omitted.

The backsight had a wider bed and strengthened axis joint. The front part was tubular in shape and encircled the barrel, to which it was fixed by a cross-pin and the point of the spring screw, to prevent it working loose. The leaf, which was made to rebound when turned over on to the hand-guard, was graduated on the left side by lines representing intervals of 25 yards, between 200 and 2,000 yards. These were in addition to the lines on the right side which represented 100 yard intervals (as on the Mark I Rifle). The slide could be set at any elevation, in multiples of 50 yards, above or below its preceding setting, by pressing a catch on the left side. This released a fine-adjustment worm-wheel from engagement in the thread notches on the right side of the leaf, thus enabling the slide to be moved quickly along the leaf. The worm-wheel was pivoted on the right side of the catch, and could be rotated in either direction at right-angles to the leaf. This movement provided fine adjustment for the slide. The periphery of the worm-wheel was divided by ten thumb-nail notches, the distance between each notch representing 5 yards in range, i.e. five notches equals 25 yards, or one division on the left side of the leaf. One complete turn of the worm-wheel represented 50 yards in range. The wind-gauge was fitted directly on the rear end of the leaf and was held in position by a screw. A "U" notch instead of a "V" notch was cut in the top edge and the face was roughened to prevent reflected light. Bright centre-lines were marked on the face of the wind-gauge for assisting the firer's aim, and on the top for use in conjunction with the wind-gauge scale on the leaf. The wind-gauge scale was marked with divisions representing the same amount of deviation on the target as the

scale on the Mark I rifle, i.e. 6 in. per 100 yards. Each quarter-turn of the wind-gauge screw represented 1 in. deviation per 100 yards and, at each quarter turn, a friction-spring engaged in a nick inside the head of the screw and checked its rotation.

The foresight was a straight-edged blade instead of a barleycorn and was provided in five different sizes. These were marked on the top left side "0", "015", "03", "045" and "06" respectively, representing 1.00 in., 1.015 in., 1.03 in., 1.045 in. and 1.06 in., their heights from the axis of the barrel.

Butt-plate. The trap of the butt-plate was fitted with an axis pin in a somewhat similar manner to that of the Lee-Metford Mark II rifle, and the trap opening was tapered in thickness.

The inner-band was 1 in. nearer to the breech-end of the barrel and was bored larger to suit the larger external diameter of the barrel at that position.

The cut-off was strengthened at the joint end, and was similar to that fitted to the Mark I* rifles.

The locking bolt was slightly modified to suit the stop pins which had been coned to ensure smoother working.

The nose-cap was lightened, and the shape of the foresight protecting wings was altered. They admitted more light to the foresight and enabled a better aim to be taken when firing at a moving target.

Rear hand-guard. The backsight protector was removed from the hand-guard.

The front hand-guard was strengthened and increased in thickness in front of the outer band.

Stock fore-end. The inner-band seating was moved 1 in. towards the breech to strengthen the fore-end. A new form of backsight protector was fitted and fixed by a screw and nut.

The aperture sight spring was recessed for the head of the screw. The screw-head was rounded to prevent injury to clothing and accoutrements.

Although dimensionally similar to the Mark I, the Mark III rifle was heavier and weighed 8 lb. 10½ oz. It was fitted with the Pattern 1907 sword bayonet. (For full details of rifle see Appendix "C".)

In accordance with established procedure, earlier patterns of British Service weapons were now brought into line with the new Mark III Short rifle. On 17th June, 1907, a pattern was sealed to govern the conversion of a number of Lee-Enfield rifles, Marks I and I* and Lee-Metford rifles, Marks II and II*. The converted rifle became the **SHORT MAGAZINE LEE-ENFIELD CONVERTED MARK IV**, and it differed from the Converted Mark II (described on page 97) by the embodiment of the special features of the new Mark III rifle. It weighed 8 lb. 14½ oz., but was otherwise the same as the Short rifle, Mark III, with the exception of the following components:

The body was special to this rifle.

The stock fore-end retained the rivet and two washers instead of being fitted with a screwed pin, and was special to the rifle.

Stock-bolt. The same as fitted to the Lee-Enfield (Long).

The butt marking disc was omitted as the butt-plate had a strap on which necessary regimental markings were made.

The butt-plate was the Lee-Metford pattern.

The butt was the pattern fitted to the S.M.L.E. Converted Mark II.

The butt-plate trap was the same as on the Lee-Metford, Mark II.

Earlier in the year approval had been given for the numbering of fore-ends and nose-caps to correspond with the serial numbers on the barrels on all Short Lee-Enfields. It was realized it was essential that, after a weapon had been correctly sighted, these components should always be assembled to the same rifles.

On 1st July, 1907, another conversion of a number of Lee-Enfield Marks I and I* and Lee-Metford Marks II and II* was approved. In this conversion the weapons were not made into Short rifles but were fitted with bridge charger-guides, new magazines for charger-loading, and modified sighting systems. After conversion the Lee-Enfields became the CHARGER-LOADING LEE-ENFIELD, MARK I* and the Lee-Metfords became the CHARGER-LOADING LEE-MET-FORD, MARK II. Details of the new sighting which was embodied in the conversion are as follows:

Blade foresight. A straight-edged blade foresight was fitted. There were five different heights and they were marked on their left sides with the figures 933, 948, 963, 978 and 993. The figures represented in decimal parts of an inch their respective heights from the axis of the barrel. The blades were of two patterns: those for the Lee-Enfield (which had the foresight block fixed .027 in. to the left of centre) were marked with the letter "E" after the figures, and those for the Lee-Metford bore the letter "M".

The backsight leaf was stronger, and the elevation lines were farther from the axis than on the old leaf. A stop screw for the slide was fitted at the top corner of the right side.

The backsight slide was fitted with a wind-gauge, adjustable laterally by a screw on the left side. A clamping nut was fitted on the right side, and, when this was screwed up, it pressed a clamping stud on to the edge of the leaf and fixed the slide in any required position. A friction spring was fitted in the leaf slot on the left side and pressed on the side of the leaf. An extension of this spring acted in notches cut at right-angles on the inside face of the head of the wind-gauge screw. The slide was marked with a scale of eight divisions on the front and rear faces, four on the left and four on the right, for the adjustment of the wind-gauge. Each division represented six inches on the target per 100 yards of range. The slide also had a platinum centre-line on the rear face. The wind-gauge

was fitted into the slide, and held and positioned by the wind-gauge screw, the necessary friction being given by a flat bowed spring fitted in the slide underneath the wind-gauge. The wind-gauge had two sighting bars with "U" notches and platinum centre-lines, one for use with the leaf raised and one for the leaf in the horizontal position. Lines were marked on the front and rear faces to correspond with the inner lines on the slide for centring the wind-gauge. The wind-gauge screw was notched at quarter-turns to receive the slide-spring extension. Each quarter-turn represented one inch on the target at 100 yards, and six quarter-turns one division on the scale on the slide. The foresight protector was fixed to the barrel by a screw.

The weight of each new charger-loading rifle was about 9 lb. 5 oz.

Three more conversions followed in 1908, all of which were for the British Naval Service. The first was approved on 4th January, and resulted in a number of S.M.L.E. Mark I rifles becoming SHORT MAGAZINE LEE-ENFIELD RIFLES, MARK I**. Later the S.M.L.E. Converted Mark II became the S.M.L.E. MARK II** and the S.M.L.E. Converted Mark II* became the S.M.L.E. MARK II***. Details of the conversion, carried out in the Royal Naval Ordnance Depots at Chatham, Portsmouth and Plymouth, which necessitated these changes in name, were as follows:

Sights. The S.M.L.E. Mark III blade foresight was fitted, and a higher wind-gauge with a "U" sighting notch was embodied in the backsight. A fine-adjustment screw, spring-tensioned, and having a larger head and finer milling, was fitted.

Body. The sharp edges on the body were removed.

Hand-guard. The hand-guard had the double spring barrel attachment.

The stock fore-end was recessed to receive a stud and spring to centre the barrel in the nose-cap. It was recessed to receive the double spring on the hand-guard.

Trigger-guard. The magazine link was removed and a sling swivel was fitted at the front end of the trigger-guard.

Magazine. The link loop was removed.

Magazine platform spring. The spring had a retaining nib to prevent movement of the platform on the spring. The nib was riveted to the spring.

Butt. A wad was inserted over the stock bolt.

Striker keeper-screw. A screw with coin-slotted head was fitted.

Locking-bolt. Sharp edges were removed where necessary.

Swivel screws. Screws were bored for centre-punching for security.

Charger-guide. A new charger-guide was fitted.

Bolt-head. The sharp edges of the front face of the bolt-head were removed.

Four years later these rifles were brought more into line with the

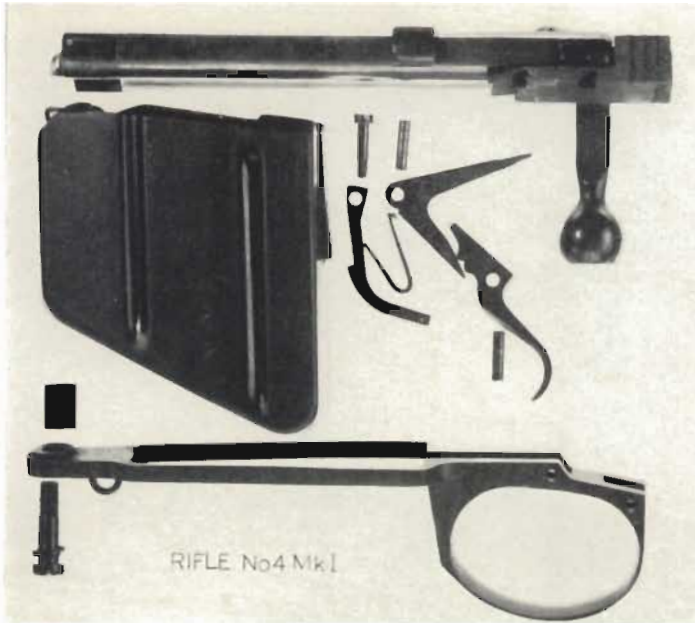

No. 4 RIFLE ACTION (Fired position)

Showing the relative position of the component parts after the trigger has been pressed; the top nib on upper arm of the trigger is in engagement with the lower arm of the sear, and the upper arm of the sear is now clear of the cocking-piece. The striker and cocking-piece have gone forward and fired the cartridge.

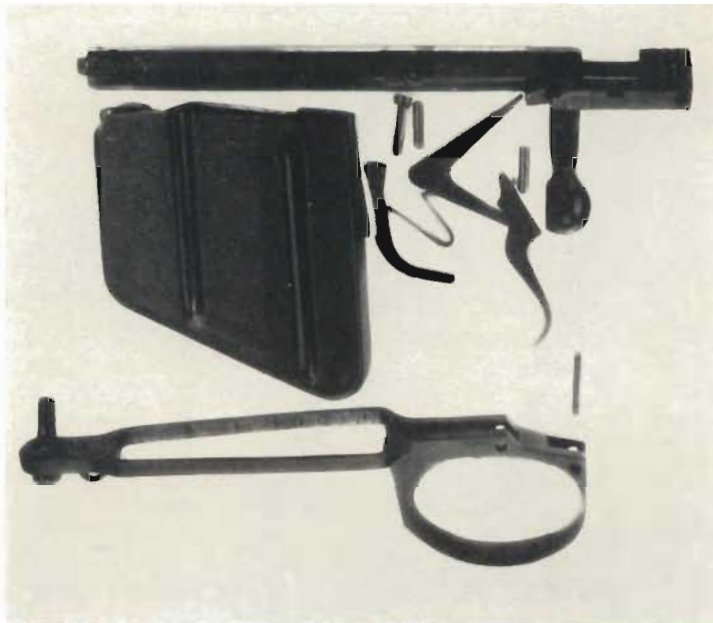

No. 4 RIFLE ACTION (Cocked position)

Showing the relative position of the component parts when the action is in the cocked position.



RIFLES AND BAYONETS OF TWO WORLD WARS
Top: No. 4 RIFLE with No. 4 MARK 1 CRUCIFORM BAYONET (World War II). *Bottom*: No. 1 (S.M.L.E.) MARK 3 RIFLE
with SWORD BAYONET (World War I).

This provides a good illustration of the respective length of the two weapons when fitted with their bayonets.

Army's Mark III pattern. The bolt-head charger-guide was removed and the bridge charger-guide was fitted. Other alterations included straightening the incurving foresight protector wings, recessing the stock fore-end for the new bridge charger-guide and fore-end stud and spring, and adjusting the stocking-up. As all the three patterns of Naval weapons were modified, no change was made in their names.

On 1st February, 1909, it was decided that the conversion of Lee-Metford rifles to charger-loading, described on page 111, should cease and those rifles which had already been converted should be called CHARGER-LOADING LEE-ENFIELD RIFLES, MARK I*. The reason for this change in name was the fitting of new breech-bolts of the same type as those fitted to the Charger-loading Lee-Enfield rifles. It was also decided that in future all Lee-Metford rifles when fitted with Enfield barrels should automatically become LEE-ENFIELD RIFLES. The following year it was decided to omit the letter "E" from the Knox-form of all Enfield barrels supplied as spares for Martini-Enfield, Lee-Metford and Lee-Enfield rifles and carbines. In the case of barrels for the Lee-Metford Mark I* the pattern numeral "I*" was also omitted.

On 5th March, 1909, a new cut-off, the Mark III, was approved for all Short Lee-Enfield, Charger-loading Lee-Enfield, and Charger-loading Lee-Metford rifles. The new pattern had the stop nibs on the rear end strengthened. The inner stop nib was altered in angle, and the outer stop nib was turned up to bear on the rifle body above the cut-off slot. A lighter nose-cap spring for the Short Lee-Enfield Mark III was also approved, it having been found that the spring which was fitted caused shots to drop, often resulting in a long straggling group on the target.

There was now an increasingly strong feeling, especially amongst target shooting enthusiasts, that some form of aperture sight for use at all ranges should be fitted to the Service Rifle. At the same time, from the purely Service angle, there was considerable opposition to the suggestion. The adoption of a new rifle for the British Army was now being seriously considered, and an aperture sight was being borne in mind in this connection. Meanwhile the aperture sight was being used in increasing numbers in competition shooting at Bisley, various patterns to fit on to Service weapons having been made by private manufacturers. On 28th July, 1909, the National Rifle Association reported to the War Office as follows: "The general result of permitting the use of certain sights, approved by the Council, which could be affixed to rifles by merely withdrawing the pins of the long range backsight, was that some form of aperture sight was being used by the vast majority of the competitors during the meeting just concluded. The beneficial use of this form

of sight has been most marked, especially in competitions carried out at Service targets, such as moving and vanishing targets, and at the running and walking man. Whilst not prepared to recommend any particular form or manufacturer's pattern of sight, the Council submitted for favourable consideration that the question of the adoption of some form of aperture sight nearer to the eye, in addition to, or substitution of, the sights on the Service rifle, may be seriously considered." Evidence was soon forthcoming that the aperture sight was being very seriously considered for embodiment in a new British Service rifle.

During 1908 and 1909 extensive trials with a lighter bullet than that of the British Service Mark VI cartridge were carried out at Hythe, Enfield Lock, and H.M.S. *Excellent* (Portsmouth). The bullet weighed 174 grains, and the rifles used were a number of Short Lee-Enfields, some fitted with barrels embodying a .4-in. "lead" and some with barrels with .6-in. "leads", and a number of Long Lee-Enfields with barrels with .8-in. "leads". The trials showed the mean velocity of the experimental cartridge to be 2,350 feet per second at 90-ft. range. Though it was not as accurate or as consistent as the Service (Mark VI) cartridge at the shorter ranges, at 800 yards and over the comparison was markedly in its favour. Accuracy at all ranges was considered sufficient for Service purposes and was unlikely to be seriously affected by worn barrels, with a degree of wear within service limits. It was found that the longest range at which the bullet would strike a man 5 ft. 6 in. in height throughout its flight was about 650 yards, compared with 550 yards with the Mark VI cartridge. At 800 yards the culminating point of its trajectory was about 9½ ft. above the line of sight and it had a dangerous space* of 120 yards. The Mark VI at the same distance rose to slightly over 14 ft. with a dangerous space of about 70 yards. Penetration of hard substances such as oak was better than the Mark VI. In soft substances such as earth or soft wood penetration was less, owing to the bullet's tendency to turn sideways on striking, the soft substance failing to resist this tendency. This was considered to be characteristic of all pointed bullets. Against such material as shingle or stones the bullet, like the Mark VI, produced very little effect. The new cartridge appeared to have suffered little from the rough usage tests to which it was subjected and was considered unlikely to lose efficiency through rough usage in the Service. It seemed probable, however, that, owing to the greater heat developed and increased friction resulting from higher pressure and greater "set up", the new cartridge would cause more trouble than the Mark VI with

* The "dangerous space" is the distance between the point where the bullet has descended sufficiently to hit the head of a man (standing or mounted) and the point where, if not interfered with, it will first strike the ground.

nickel fouling. The adoption of the new bullet would make it necessary to alter the backsights of all Service rifles. The curve of the ramp would have to be adapted to match the trajectory curve of the new bullet and the leaf of the Long rifle backsight would require re-graduation. Both Long and Short rifles would need a re-graduation of their long range dial sights. No difficulties had been experienced in charging magazines with the new cartridge but, in loading from the magazine into the chamber, there had been a tendency for the last but one cartridge to sometimes tilt upwards, causing a misfeed when pushed forwards by the bolt. It was thought that a slight alteration to the magazine might be necessary. It was considered reasonable to expect greater wounding power with the new bullet than with the Mark VI. There was no noticeable difference in recoil. On the 21st May, 1909, the Small Arms Committee recommended the adoption of the new bullet for the British Service as a temporary expedient pending the introduction of an entirely new design of rifle and ammunition.

On 3rd November, 1910, the new cartridge was introduced. Far from being a temporary expedient, it was destined for a longer life in the British Service than any of its predecessors. It was to be expended in millions in two world wars, and was to partner the Lee-Enfield rifle to the end of their service lives. It was called the .303-in. S.A. BALL CARTRIDGE MARK VII and it differed from the Mark VI cartridge principally in the shape and weight of the bullet, and in the charge which consisted of Cordite M.D.T. Details of the new cartridge were:

The bullet was pointed and weighed 174 grains. It had a lead-antimony core (2 per cent antimony) enclosed in a cupro-nickel envelope. In the pointed end of the envelope was an aluminium tip which was required partly to bring the bullet to the correct weight and partly to balance it for accurate shooting. A cannellure near the rear end of the bullet was filled with beeswax. This was for purposes of lubrication and also for waterproofing the joint between bullet and case. Three indents into the cannellure secured the bullet in the case.

The charge consisted of about 37 grains of M.D.T. (5-2), the modified cordite in tubular form.

The case was made of solid drawn brass, the base being recessed to form a cap chamber and an anvil; two fire-holes connecting the cap chamber to the interior of the case.

The cap was of copper-zinc alloy and was pressed into the cap chamber and ringed in. The joint between cap and case was varnished.

The priming consisted of about six-tenths of a grain of cap composition. This was pressed into the cap, covered with a disc of varnished lead-tin foil, and then varnished over the disc.

The length of the bullet was 1.275 in. and the length of the complete cartridge 3.037 in.

The weight of the cartridge was about 386 grains.

Mark VII Z. When the cartridge was loaded with nitro-cellulose it became the MARK VII Z, and was used principally in machine-guns.

Contrary to previous practice the word "Cordite" was omitted from the name of the new cartridge, but it was not until 20th February, 1913, that it was officially announced that "Cordite" would be omitted from all future Small Arms Ammunition nomenclature. On the same day the various Marks of S.A.A. were classed as follows:

Marks II and III. For suitably sighted .303-in. small arms and machine-guns.

Mark IV. For all suitably sighted small arms only.

Marks V, VI and VII. For all suitably sighted small arms and machine-guns.

An experiment was carried out by the Chief Inspector of Small Arms in June, 1913, to determine the effect produced by firing a rifle which had the bullet from the preceding round stuck in the bore. The following results were obtained:

1. Base of stationary bullet (i.e. the bullet stuck in the bore) almost in contact with the nose of the moving bullet
Result: Bolt-head blown back and case burst; no perceptible bulge in the barrel. Both bullets blown clear of the muzzle.
2. Base of stationary bullet from 4 to 9 in. from the face of the chamber.
Result: Barrel bulged. The moving bullet passed through the envelope of the stationary bullet, which was expanded into the bulge, and was blown clear of the muzzle.
3. Base of stationary bullet from 9 to 14 in. from the face of the chamber.
Result: A hole was blown in the side of the barrel which was also bulged.
4. Base of stationary bullet beyond 14 in. from the face of the chamber.
Result: Muzzle end of barrel blown off.

These results were not due to the compression of the air cushion between the bullets, as the boring of holes in rear of the stationary bullet was found to have no effect on the results.

The introduction of the Mark VII cartridge, with its flatter line of flight, necessitated an alteration to the sights of all rifles in the British Service which were to use the new round. The shape of the bullet also made necessary certain small alterations to magazines. S.M.L.E. rifles, Marks I, I*, III, Converted Marks II, II* and IV,

in the hands of troops and in Ordnance Stores, all had to be altered, and the sealed patterns governing the manufacture of Marks III and Converted Mark IV had to embody the necessary modifications. On 6th July, 1911, details of the alterations were announced in "List of Changes" as follows:

For Rifles in the hands of troops and in Store.

Backsight bed and spring. The ramps were reduced to give lower elevations. The spring was shortened and bevelled at the rear end to clear the slide when it its lower position. Existing springs, held as spares in units or in store, were similarly altered.

Backsight spring screw. In Rifles Marks I and I*, and Converted Marks II and II*, a shorter headed screw to clear the slide was fitted to the backsight spring.

Backsight slide. For Rifles Marks I and I*, and Converted Marks II and II*, the slide was reversed on the leaf. It was altered to suit the reduced ramps by bevelling the rear of the underside to form a new ramp seating. Recesses were cut right and left of the rear of the slide to form clearances for the knuckles of the bed joint, when the slide was set for extreme elevations. A groove was cut through the underside to clear the reduced head of the screw. The figure "2" was marked on the original ramp seating. In the Mark III and Converted Mark IV rifles the ramp seating was bevelled at the front to clear the ramps of the sight-bed. A groove was cut on the underside to clear the head of the spring screw. The figure "2" was marked on the ramp seating.

Foresight barleycorns and blades. Two barleycorns, .015 in., and .03 in. lower than the existing lowest barleycorn, and three blades .015 in., .03 in. and .045 in. lower than the lowest existing blade, were introduced for use as required. The barleycorns were marked on the top left side with the figures "9" and "915" and the blades "-06", "-045" and "-03", representing respectively .9 in., .915 in., .94 in., .955 in. and .97 in. in height from the axis of the barrel. The .99 in. barleycorn and the 1.045 in. blade were not used on rifles sighted for Mark VII ammunition.

Dial sight. Existing graduations were milled off, and the plate was re-graduated. Where the dial plates had been rendered too thin through previous conversions, new plates were fitted. Dial plates were marked "L.E.S.2" on their faces.

Magazine case. The Nos. 1 and 2 magazine cases were altered by removing a portion of, and riveting a lip to, the front left side. A spring was fitted to the back rib to hold the front end of the magazine up in position. Altered magazine cases of both patterns were marked with the figure "3" on the back rib.

Magazine platform. The platform was reduced on the front left side to allow it to clear the lip when stripping and assembling. It was marked with the figure "2" on top.

Magazine platform auxiliary spring. The set of Nos. 1 and 2 springs was altered to improve the feeding of the cartridges into the chamber. Altered springs were marked with a "3".

Body. A clearance was cut on the magazine-way for the lip of the magazine. The cartridge lead was polished and prominent corners were rounded.

For Rifles of future manufacture and conversion.

Sights. As for rifles in the hands of troops.

Magazine case. A magazine specially designed to suit the Mark VII cartridge was fitted. It differed from the altered case in having a fixed lip, instead of a stop clip, on the right front side, and a fixed lip on the left front side. Both lips were formed integral with the case. The magazine was marked with the figure "4" on the back rib.

Magazine platform. The magazine platform had no bottom plate, and was narrower at the front end than previous patterns, to facilitate stripping and assembling. It was marked on top with the figure "3".

Springs. The magazine platform spring was attached to the platform by rivets, and marked on the top bend with the figure "2". A new pattern auxiliary spring, marked with the figure "4", was fitted.

The body had a clearance cut on the magazine-way for the lip of the magazine. The cartridge lead had the sharp edges removed and was polished.

Marking. All rifles had the letters "H.V." (for high velocity) marked on the barrel, underneath the backsight leaf.

It was decided not to alter those rifles in the Naval Service until such time as Mark VII ammunition became available.

With the imminence of war, small arms became high priority (to the British War Office) and, to render as many as possible suitable for the Service Mark VII cartridge, three conversion programmes were launched in quick succession. The first, announced on 22nd April, 1914, was the conversion of the S.M.L.E. Mark I* to S.M.L.E. MARK I***. To equip the rifle for the Mark VII cartridge the backsight was altered and fitted with a wind-gauge similar to that fitted to rifles in the Naval Service. Blade foresights were also fitted. On 2nd October, 1914, conversion of the Charger-Loading Lee-Enfield Mark I* was approved. The alterations were:

Backsight. The ramps of the bed were reduced to give lower elevations, and new leaves, graduated up to 1,900 yds., were fitted. The head of the spring-screw was reduced to clear the slide. The leaves were marked "I* 2" at the right bottom corner.

Foresight. The foresight blades were of six lower heights than those previously fitted. They were marked on the top left side with the letters "E" or "M" according to whether the barrels had Enfield

or Metford rifling. They were also marked with figures showing their respective heights from the axis of the bore.

Dial sight. Old graduations were milled off and the plates re-graduated from 1,700 to 2,700 yds. The plate was marked "C.L." (for Charger-Loading) on the face.

Minor modifications to body and magazine were as already described for the S.M.L.E. Mark III.

On 14th December, 1914, the Charger-Loading Lee-Enfield Mark I was approved for conversion. This pattern rifle had never been officially introduced in "List of Changes" although it had been converted to charger-loading on the same lines, and from the same Marks of rifles, as the Charger-Loading Lee-Enfield Mark I*, except that the sights (solid unadjustable foresight and backsight without a wind-gauge) had been left untouched by the conversion. The body also differed from that of the Mark I* in having a groove cut through the bridge charger-guide to clear the line of sight at the lower elevations. Details of the conversion to adapt the weapon for the Mark VII cartridge were:

Backsight. The ramps of the backsight bed were reduced to give lower elevations, and a new leaf was fitted. This had central "V" notches in cap and slide and was graduated for elevations up to 1,900 yds. The leaf was marked "C.L." at the right bottom corner. Existing slides which had centrally cut "V" notches were refitted.

Foresight. Rifles which had the barleycorn .05 in. left of the axis of the bore were fitted with a removable barleycorn placed .02 in. left of the bore axis.

Dial sight. Old graduations were milled off and plates re-graduated from 1,700 to 2,700 yards. Plates were marked "C.L." on their faces.

On 18th August, 1915, the following action was taken with the rifles in the British Navy, the S.M.L.E. Marks I**, II** and II***:

1. A number were transferred to the Land Service.
2. All rifles were altered to take the Mark VII cartridge, the special wind-gauge and blade foresights already fitted being retained.
3. Those Mark I** rifles which were still without the bridge charger-guide, on being altered to take the Mark VII round, were re-named S.M.L.E. Mark I***.

With the formation of the new British Armies, every effort was made to speed up rifle production. Suggestions were made to dispense with certain components and to modify others, and trials were carried out to ensure that weapon efficiency was not adversely affected. The S.M.L.E. Mark III was now the rifle in large-scale

production and, when the approved modifications were adopted on 2nd January, 1916, the rifle became the SHORT MAGAZINE LEE-ENFIELD, MARK III*. The modifications were:

1. Omission of long range dial and aperture sight.
2. Lug on striker collar omitted.
3. Swivel lugs on trigger-guard replaced by wire loop.
4. Wind-gauge on backsight replaced by a fixed cap.
5. Body not slotted and drilled for the cut-off, which was omitted.
6. Later—butt marking discs were omitted.

From the above modifications it will be seen that the pattern of war had changed from South African days. Long distance sights and wind-gauges were no longer needed and of little value in trench warfare, where the emphasis was on quick shooting often at very short ranges. Four months later, consequent on the abolition of long range sights from new rifles, the following arrangements were made for all Short and Long Lee-Enfields already in the Service:

1. When bead, pointer, spring or pivot screw became unserviceable the whole of the long range sights were removed, the plate and fixing screw alone being left to cover the hole in the fore-end.
2. When dial plate or fixing screw became unserviceable they were removed and the hole was plugged.
3. When the aperture sight became unserviceable, the pillar was filed off at the base, and the base disc used as a washer under the spring.

On 5th August, 1916, approval was given for cocking-pieces fitted to the S.M.L.E. to have no knurled head. Instead, more metal was left above the striker-hole and three finger-grooves were cut on each side to afford a grip when cocking the rifle without operating the bolt.

Amongst British infantry regiments were battalions composed entirely of men of small stature. These were known as Bantam battalions and, in order to make the rifle a more comfortable weapon for the men to handle, a "Bantam" butt was introduced on 18th June, 1918. It was fitted to the S.M.L.E. rifle, was 1 in. shorter than the "Normal" butt and $\frac{1}{2}$ in. shorter than the "Short" one. It was marked with the letter "B" just above the seating for the heel of the butt-plate.

The term "E Y", an abbreviation of the word it represented, i.e. "Emergency", was the classification given to weapons fit for use in times of emergency only. On 9th December, 1918, approval was given for a number of them to be strengthened for the purpose of firing rifle grenades from a cup discharger fitted to the muzzle of the rifle. The weapons to be strengthened were for use at Army



RIFLE N°5



RIFLE N°4

THE No. 5 RIFLE MARK I

The No. 5 Rifle fitted with its bayonet and scabbard. This lightened and shortened version of the No. 4 Rifle was designed to meet the needs of the British soldier in Jungle warfare. It proved a very popular weapon and, after the war, came near to replacing the No. 4 Rifle as the standard Infantry arm.

BRITISH SERVICE RIFLE CARTRIDGES 1867-1958

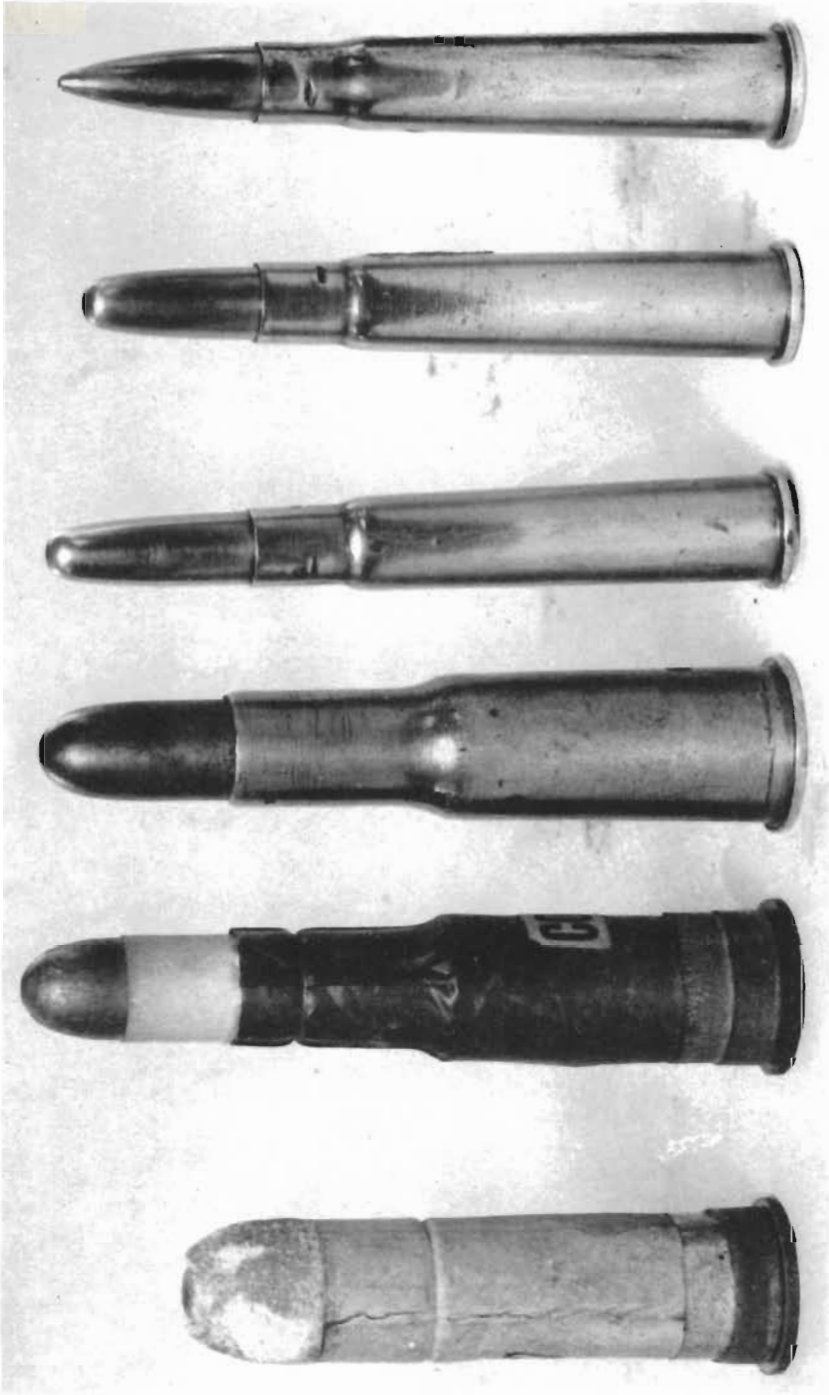

BOXER
1867

MARTINI-HENRY
(wrapped brass
case) * 1871

MARTINI-HENRY
(solid drawn
case) 1886

.303-in.
(Mark 1)
* 1891

.303-in.
(Mark 6)
* 1904

.303-in.
(Mark 7)
* 1910

* Year of introduction.



BRITISH SNIPERS' RIFLES IN TWO WORLD WARS

Top: PATTERN 1914 ENFIELD RIFLE FITTED WITH PATTERN 1918 TELESCOPE SIGHT
This became the standard sniping equipment for the British Sniper towards the end of World War I. It was also used in World War II until superseded by the No. 4 Rifle and T/S.

Bottom: No. 4 RIFLE FITTED WITH No. 32 TELESCOPE SIGHT
This equipment succeeded the Patt. 1914 Rifle in World War II and proved very popular. The Telescope, which was primarily designed for the Bren L.M.G., embodied both vertical and lateral adjustment. A little on the heavy side, it was nevertheless an efficient instrument for sniping.



RIFLE N° 3.



RIFLE N° 5.

THE No. 5 RIFLE MARK I

The No. 5 Rifle, often unofficially referred to as the Jungle Carbine, together with its short sword-bayonet.

Schools of Instruction, and the approved method of strengthening was as follows:

1. They were fitted with a wood screw passed through the stock fore-end, to prevent splitting, and bound with whip-cord or copper wire to prevent injury by splinters in the event of the barrel bursting when firing grenades.
2. A $1\frac{3}{4}$ -in. No. 12 wood screw was fitted at right-angles through the fore-end at a point $1\frac{1}{2}$ in. from the front of the trigger-guard and $\frac{1}{8}$ in. from the top edge. Binding commenced at the rear end of the swivel-lug on the nose-cap and extended 5 in. towards the breech end of the rifle.
3. When copper wire was used for binding, the last five turns were soldered together.

At the beginning of 1919 there was a request from the British troops in France for a more certain means of getting off twenty rounds of continuous fire with a rifle under the existing conditions of trench warfare. When men and equipment became plastered with mud it was often impossible to keep it off the chargers and, in loading, it was inevitably transferred into their magazines, and caused malfunctioning. Ways and means were sought to obviate this danger and eventually magazines were designed to hold fifteen and twenty rounds. A number of these were submitted to trials at the war-time School of Musketry at Bisley and, although the twenty-round magazine gave an increased rate of fire, this was more than outweighed by many disadvantages. Difficulties were experienced in charging up the last five rounds, and firers complained of tired muscles due to continuous action, and consequent loss of control of their weapons. The big magazine interfered with the grip of the left hand on the rifle and with efficient use of the bayonet. It was also considered too cumbersome and liable to damage. In view of the many serious disadvantages the large magazine was not recommended and, with the war ending, the requirement was given no further consideration.

When the Short Magazine Lee-Enfield Rifle was adopted by the British Army it was received with much adverse criticism, especially from the target-shooting enthusiasts. The late L. R. Tippens in his book "Modern Rifle Shooting", published a few years after the Short Rifle was adopted, stated "The rifle trade has nothing but contempt for the short rifle" and, in summing up the new Service weapon, said that he considered it to be "Weaker, dearer, less durable, kicks harder, and is less accurate than the long rifle and almost every other service rifle". Whatever its merits as a target rifle may have been when this was written, in all other respects it was soon to show its worth as one of the most efficient weapons ever to be put into the hands of a fighting soldier. In the early days of

the war, in the fierce battles around Mons and Le Cateau, when the British Army was fighting for its life against tremendous odds, it was the effective rapid fire of the Short Lee-Enfield, in the hands of the superbly trained British infantryman, that caused such heavy casualties in the ranks of the advancing German Army. The riflemen at Mons, armed with Lee-Enfields, proved worthy descendants of the archers of Crecy and Agincourt. And in the days that followed, in the mud and slime of the Western Front and the desert sands of Eastern theatres of war, the Short Rifle provided a most effective answer to all its critics.

CHAPTER XI

THE PATTERN 1914 ENFIELD RIFLE

IN August, 1910, the Small Arms Committee were asked by the War Office to consider the question of a suitable mechanism for a new magazine rifle for the British Service and, on 2nd September, the following points had been agreed:

1. The rifle should be common to both Cavalry and Infantry.
2. The length and weight should be as near as possible to that of the Short Lee-Enfield.
3. A one-piece stock fore-end was recommended as this appeared to be cheaper and more serviceable than having the stock in two pieces.
4. The trapped butt-plate should be retained.
5. The principle of nose-cap bayonet attachment and method of supporting the barrel should be adhered to. The nose-cap to be lightened if possible, providing sufficient support for the bayonet was assured.
6. The hand-guard to be the full length of the barrel.
7. As a barrel weighing 2 lb. 14 oz. appeared to give the best results the weight should be as near as possible to this, if the total weight of the rifle allowed it.
8. The recoil should be about the same as the S.M.L.E.
9. The magazine should be detachable and contain 10 rounds.
10. The rifle should be charger-loading, and have no cut-off.
11. The breech action should be of the Mauser type which was strong, reliable and symmetrical. The general characteristics should be: (a) Forward locking-lugs, with secondary safety shoulder to the bolt, (b) Bolt-head detachable, or solid with bolt.
12. It should fire rimless cartridges.
13. The trigger should be directly connected with the body of the rifle and not attached to the trigger-guard.
14. The safety-catch should be capable of being locked in both the fired and cocked positions.
15. The striker to be controlled by the cocking-piece.

16. The present sighting system on British Service rifles should be replaced by an aperture backsight, adjustable for all ranges up to 1,600 yards, and located on the rifle about four inches from the eye. The present pattern dial sight and aperture should be retained for distances beyond 1,600 yards. A fixed sight for all ranges up to 700 yards should, if possible, be added in conjunction with the aperture backsight.

It was decided to make an experimental rifle embodying, as far as possible, the points recommended; the calibre to be .276-in. chambered (as a provisional measure) to take a cartridge with a 150-grain bullet, this being one that was under trial by the Ordnance Board. The rifle was to be stocked-up on the lines of the U.S.A. Short Springfield 1903 model and it was eventually decided to alter a Short Springfield rifle as far as possible to comply with the Committee's requirements. The rifle was developed at the Royal Small Arms Factory, Enfield, and eventually a number of experimental weapons were prepared for trials at Enfield and Hythe. At the same time other patterns, including two put forward by the B.S.A. Company, Birmingham, were considered and tested. As a result of the trials it was decided to manufacture 1,000 of the Enfield pattern rifle for troop trials, but one serious problem had yet to be overcome. This was metallic fouling of the barrel and a Small Arms Committee minute dated 10th May, 1912, shows just how serious the problem was. It read: "The Committee desire to point out that no cartridge has yet been produced for the .276-in. rifle which does not give such metallic fouling as to quite preclude its being tried by the troops in the 1,000 rifles about to be manufactured, and the Committee see little prospect of arriving at a satisfactory solution of this problem by the time when a decision as to cartridge will be required if the trial of 1,000 rifles by the troops is to be carried out next year." Their opinion was that the main cause of the fouling was the high pressure, combined with the high temperature, of cordite M.D.T., and they made certain recommendations as to what they considered should be the composition of the new cartridge.

Early in 1913 a trial was carried out to ascertain the cause of metallic fouling. The trial was not completed as a steel-coated bullet had in the meantime overcome the trouble. Interesting results were obtained by the simple friction of two surfaces under various pressures. The experiments showed that metallic fouling could be produced without the aid of powder gases or other products of combustion, and the tendency to fouling varied with pressures. Polish on steel also seemed to influence the amount of fouling, a highly polished steel being more fouled than one less highly polished. The experiments also revealed a decided advan-

tage, as far as reduction of fouling was concerned, in using a hard steel for rifle barrels in preference to a softer steel. Lubrication of the bullet reduced the metallic fouling and increased the efficiency. Later in the year the new .276-in. ammunition was tested at Hythe in comparison with some special Mark VII, made up with selected components and weighed charges. The results showed that the new cartridge, though not as good as was hoped for, was more satisfactory than at first appeared likely. A further trial was carried out to ascertain if accuracy was affected by strength of striker blow. A striker spring was gradually shortened till the blow was such that misfires occurred. The results indicated that the ballistics and accuracy were practically unaffected by the strength with which the cap was struck. Towards the end of the year wounding power trials were carried out on Plumstead Marshes against animal carcasses and the results were considered to be quite satisfactory up to distances of at least 2,000 yards. With a view to reducing metallic fouling and wear of bore, trials were carried out with bullets having cannelures, producing the effect of driving bands. Bullets having two of these were tried but failed to centre properly. Three gave a great improvement in engraving but the results were still unsatisfactory.

A thousand rifles were manufactured at Enfield and, early in 1913, were issued to British troops in the Aldershot, Irish, Southern and Northern Command, South Africa, Egypt, and the School of Musketry, Hythe. Particulars of rifles and ammunition used in the trials are as follows:

Rifle.

Weight (with empty magazine)	8 lb. 11 oz.
Length (without bayonet)	3 ft. 10·3 in.
" (with bayonet)	5 ft. 3·3 in.
" of barrel	2 ft. 2 in.
Weight " "	2 lb. 15 oz.
" " sword bayonet (without scabbard)	1 lb. 2 oz.
Calibre	·276 in.
Rifling	..	Enfield	..	left-hand twist, 1 turn in 10 in.
" Number of grooves	5
" Depth	·005 in.
" Width	·0853 in.
" " " lands	·0853 in.

Sighting system.

Removable blade foresight in varying heights.

Backsight fitted to rear end of body consisting of a leaf and slide, with aperture of ·1-in. diameter. There was no wind-gauge nor fine adjustment, and the leaf was graduated from 400 to

1,900 yards. There was a fixed aperture sight for ranges up to 600 yards, and a dial sight (ungraduated) similar to that on the S.M.L.E. rifle. The sight radius measured 31·68 in.

The action had front locking lugs and resembled the Mauser.

The stock was one-piece and the *magazine* held five rounds.

Ammunition.

The cartridge case was rimless.

The bullet. The core was lead and antimony and the envelope was mild steel plated with cupro-nickel. Its diameter was ·282 in. and it weighed 165 grains.

The charge was 49·3 grains of cordite M.D.T.

The overall length of the cartridge was 3·230 in.

Muzzle velocity 2,785 f.s. as against 2,440 f.s. of the ·303-in. Mark VII cartridge.

Vertex of trajectory at 800 yards, 5·23 ft. as against 9 ft. of the ·303-in. Mark VII.

The method of loading the rifle was by charger holding five rounds.

The advantages claimed for the new weapon as compared with the Short Lee-Enfield were:

1. It had increased muzzle velocity and flatter trajectory.
2. The bolt-locking in front gave greater rigidity to body and bolt.
3. It had greater strength, simplicity, and reduced number of component parts.
4. The action and bolt could be stripped without tools.
5. The different form of stocking allowed a lighter nose-cap to be used and improved the balance of the rifle; the weight being concentrated near the centre of gravity.
6. The stock, being in one piece, the possibility of loosened butts obviated.
7. The use of aperture sights for all ranges and an increased length of sight radius.
8. The provision of a fixed, or battle, sight.
9. The magazine was entirely contained in the stock, thus facilitating handling and avoiding damage.
10. After the last cartridge had been fired, the magazine platform prevented the bolt from closing, thus warning the firer that the magazine was empty.
11. Reduction in weight in other parts allowed the provision of a heavier and stronger barrel, and admitted the use of a simpler form of stocking-up.
12. Fewer projections on the rifle facilitated handling.

In June, 1913, the G.O.C.-in-C., Aldershot, reported that the trials had been suspended, owing to severe damage to one rifle. It

was found that the ammunition had a great heating effect on the rifle and if, after continuous fire a round was left in the heated chamber for a short time, dangerous pressures were developed. As a safety precaution, the programme was amended so that not more than fifteen rounds were fired without the rifle being allowed to cool off. The reports from Commands brought to notice the following points:

Ammunition.

1. High pressure, due to the heating effects.
2. Difficulty in extraction, especially with a heated rifle.
3. Very loud report.
4. Very large flash.

Rifle.

1. The rifle, on the whole, did well and was popular with the men.
2. There was a tendency for the face of the bolt to shear the edge of the magazine platform.
3. The hand-guard appeared to be weak.
4. The grooves in the hand-grip were not satisfactory.
5. The safety-catch required alteration.
6. The knob of the bolt tended to strike the forefinger of the right hand of the firer.
7. The magazine spring required slight alteration to prevent its being replaced upside-down, and so interfere with the feed.
8. There was a slight tendency to misfire.
9. The edges of the butt-plate were slightly sharp.
10. The backsight aperture needed improvement.
11. The figures on the backsight were indistinct.
12. There was a danger, when advancing with the backsight raised, of a blow damaging the sight.
13. The guides for the charger were not prominent enough.
14. Difficulty was experienced in getting the oil bottle and pull-through into the place made for them in the butt.
15. There was a tendency to pick up sand in the muzzle when loading the rifle on sandy soil.
16. The feed from the magazine was not satisfactory.
17. The steel butt-plate was inclined to rust.

An immediate investigation was put in hand and an improved design of rifle, based on the points brought to notice by the trials, was submitted to the Small Arms Committee, and, at the beginning of 1914, six rifles to the improved design were being manufactured for further trials. Although most of the troubles were soon dealt with there were a few which had no easy solution. The flash, visible for a mile at night, and the loud report were considered to be very

serious, and experiments with new propellant charges, including cordite with a reduced percentage of nitro-glycerine, were put in hand in an effort to cure this trouble. Barrel wear was another serious problem. It was often bad after only 1,000 rounds had been fired, and accuracy was seldom retained after 3,000. Experiments took place with new barrel steels, and improvements were expected when a new propellant charge, with smaller proportion of nitro-glycerine, was perfected.

Many of these experiments, however, were never concluded, owing to the outbreak of the World War and the plans for the new rifle, which so nearly concluded the life of the Lee-Enfield as the British Service arm, were drastically changed. The new weapon did eventually serve a very useful purpose. It was converted to take the .303-in. British Service cartridge and, there being no available manufacturing facilities in the United Kingdom, arrangements were made for the rifle to be made at the Winchester, Remington and Eddystone factories in the United States. It now became known as the PATTERN 1914 ENFIELD RIFLE and was adopted as the sniper's rifle for the British Army. In this capacity it was fitted with either the Pattern 1918 telescope sight or the Aldis offset, and was still in use in the early days of World War II. With the .303-in. Mark VII cartridge, it proved to be a very accurate weapon and became a great favourite with many Bisley competitors, especially at the shorter ranges. In May, 1926, when British Service rifles became known by numbers, it became the No. 3 Rifle.



THE No. 1 RIFLE MARK 6

The No. 1 Mark 6 Rifle fitted with a No. 4 Mark 1 Bayonet. This was the immediate predecessor of the No. 4 Rifle and was not adopted for the British Service. Except for the chequering on the fore-end, it differed little externally from the No. 4. The main difference was in the body, which was modified to improve accuracy. Only a limited number were made for trials.



THE No. 4 RIFLE MARK 1

Approved for manufacture in November, 1939, this rifle was produced in millions for the British, Commonwealth, and certain Allied Forces. The Mark 1* Model was made in Canada and the U.S.A. It proved to be a very accurate and serviceable weapon. The illustration shows the mass-produced weapon made during the war.

CHAPTER XII

A NEW RIFLE AND A NEW TYPE OF BAYONET

FOR several years prior to the 1914-18 war, the question of an entirely new design of rifle for the British Service had been under serious consideration. But for the war, the rifle described in the previous chapter would almost certainly have been adopted, but war experiences had changed ideas on what was most needed in an infantry weapon. A calibre of .276 in. was now thought to be too small to allow a bullet to contain an adequate armour-piercing core, or a sufficient quantity of material for tracer or incendiary purposes.

As the name implies, the tracer bullet leaves a visible wake behind it. This allows the firer to see where the bullets are going and make any corrections of aim that appear necessary. It is largely used in machine-guns and it is customary for a percentage of belts or magazines to be loaded with a percentage of tracer cartridges. The bullet of the tracer cartridge has a two-part core covered with a cupro-nickel envelope. The front of the core is lead-antimony alloy and the rear part consists of a copper cylinder, open at the rear end, and filled with tracer composition. The tracer composition burns during flight and, as it is consumed, the bullet becomes lighter. This affects the line of flight, especially at distances beyond 600 yards, when it differs considerably from that of the normal service round. The armour-piercing bullet consists of a hard steel core in a soft steel envelope coated with cupro-nickel. The softer envelope and lead sleeve are necessary to ensure the bullet taking the rifling when the cartridge is fired. Between the envelope and the core of the bullet is a sleeve of lead-antimony and, on the bullet striking its objective, envelope and sleeve flatten out. This supports the point of the hard core as it commences to make penetration. As penetrating power depends largely on striking energy, weight of core and velocity must be to the highest possible limits.

During the years immediately following the war the weapon designers devoted much time and thought to the proposed new British Service rifle and suggestions came to the Small Arms

Committee from several different sources. Automatic loading, but not automatic fire, was much favoured, and it was considered that the rifle should accommodate a short bayonet, 7 to 8 ins. in length. It was suggested that all rifles should be tested for accuracy at the factories with the bayonet attached before they were accepted for service, and that they should be made of rustless steel if this was available. It had been noted during the war that German rifles were less prone to rust than the British. A simple contrivance for firing rifle grenades which could be quickly fitted to the muzzle was considered a requirement on the new rifle and, if possible, a silencer for the sniper. A forward locking action was favoured if a short one could be designed which did not hit the firer's face when the bolt was withdrawn. The action of the Pattern 14 Rifle was unpopular in this respect and was considered unsuitable for rapid fire.

The question of providing an automatic rifle for the British Forces was still under serious consideration and, by 1922, a requirement for a more efficient lighter machine-gun was becoming a matter of major importance. The opinion of the British General Staff was that the limit had been reached in the weight of ammunition a soldier could carry on service, and an automatic rifle would probably entail greater expenditure of ammunition which he would be unable to carry. If, however, foreign armies equipped their infantry with automatic rifles, even if accuracy of fire was not greatly increased, the moral effect would cause them to follow suit. They considered that, as far as money permitted, experiments should continue with an automatic rifle and, if a light weapon firing the Service .303 cartridge could be produced, it might be extremely useful for cavalry, gunners, tank crews, etc., who might need rapid bursts of fire for short periods. The rifle would then be available if required for general adoption later on. They were in favour of devoting principal attention to a new machine-gun as the best means of increasing the fire power of the British Army. (It was not until May, 1935, that the Bren was approved to replace the Lewis as the British Light Machine-gun.) Future policy would therefore be to concentrate energies on the production of a light and more effective machine-gun and continue experiments on the design of an automatic rifle and, at the same time, investigate the following points:

1. The feasibility of producing a reliable aperture sight which could be easily attached to the Service rifle in such a manner that it would not be easily damaged.
2. The possibility of using rustless metal in weapon construction.
3. An improved bolt action.
4. Retention of a cut-off.
5. Provision for firing rifle grenades.

6. The advisability of a shortened bayonet, even if it could not be used when the rifle grenade cup was fitted. A special sub-committee was appointed to investigate these matters.

Eventually a pattern of a modified service rifle was sealed to govern possible conversion and future manufacture, and it was named the SHORT MAGAZINE LEE-ENFIELD RIFLE, MARK V. It differed from the Mark III Rifle in the following particulars:

1. It had an upper band, approximately $4\frac{1}{2}$ inches from the muzzle, let into recesses in the stock fore-end and front hand-guard. It carried a centrally placed piling-swivel which was attached to the nose-cap lugs by a screw. The band was not hinged but was sprung over the fore hand-guard.
2. The rear hand-guard was made in one piece, extending from the reinforce to the lower band, and was approximately $12\frac{1}{4}$ inches in length. As on the Mark III, it was held in position by a double spring over the barrel just forward of the reinforce and, at the other end, by the lower band.
3. The stock fore-end differed only by the omission of recesses for the backsight assembly, the backsight projectors, and the dial and aperture long range sights.
4. The nose-cap screw had a large head with a coin-slot.
5. The Mark III rifle backsight assembly and long range sights were omitted.
6. The cut-off differed in that the spotting and production hole, used to facilitate manufacture (and not, as has been alleged, used for the purpose of cutting off the noses of bullets) was omitted.
7. The rear sling-swivel lugs on the trigger-guard were omitted, and were replaced by a wire loop offset to the left, and in rear, of the trigger-guard screw.
8. The rear of the cocking-piece was narrower and deeper. The sides were parallel and had three recesses on each side.
9. The Mark III magazine was fitted.
10. The backsight was a tangent leaf sight of the folding type. The rear of the bridge charger-guide was recessed to form a housing for the leaf when folded down in the horizontal position. The leaf was graduated from 200 to 1,400 yards in steps of 100 yards. It carried a slide on which there were two apertures, one of which, the battle- or fixed-range sight, was in position for use when the leaf was folded down. With the leaf in the upright position, the slide could be moved to any desired elevation, in which it was secured by a spring-loaded catch engaging in serrations on the left side of the leaf. The diameter of each aperture was .10 in. The sight was located between two lugs at the rear extremity of the body of the rifle and was

attached by two screws. The leaf was approximately one inch in width and the sight-base was $30\frac{3}{8}$ in. in length.

A Mark V Rifle was on view at the Bisley Prize Meeting of 1923, and the National Rifle Association arranged a special competition for it at the 600 yds. range. The weapon was used by civilian and service marksmen and criticisms on which there was general agreement were:

1. The rifle was not properly zeroed, and trigger pressure at first was about 8 to 10 lb.
2. Inaccuracy, including many low shots.
3. No provision on the backsight for adjustments of less than 100 yards. These adjustments were not fine enough for target shooting.
4. The size of the apertures, and the dimensions of the metal in which they were located, were adversely criticized, although it was generally agreed that such criticisms were based on the target shooting angle rather than on use in the field.
5. Some officers were of the opinion that the backsight would get in the way during bayonet fighting and certain rifle exercises.
6. It was considered more difficult to "aim off" when using the aperture sight than with the "U" backsight on the Mark III Rifle. For this reason several regimental officers expressed the view that it might prove more difficult to teach recruits with the Mark V.
7. The aperture backsight system was generally approved. Service firers recognized the necessity of the large apertures in the backsight and the construction of the slide to allow a good view of the "target area", and the absence of a wind-gauge, but general disappointment was expressed that the S.M.L.E. barrel had not been replaced by a heavier one.

The Mark V Rifle had been developed with the dual object of providing a new rifle, and a pattern to which earlier marks of S.M.L.E. could be converted. The principal components involved in the conversion were the body, the barrel, stock fore-end, hand-guards and nose-cap, and the most important decision to be made was whether the bodies should be modified to accommodate the new aperture backsight or whether entirely new bodies, necessitating considerable extra expense, should be made. In the manufacture of Lee-Enfield rifles the lineability of barrel and body had always to be very carefully watched. Correct lineability could only be obtained when the bearing faces of barrel and body, when breached up, were absolutely square with the axis of barrel and body. It was considered that this might be very difficult to achieve successfully with rifles of wartime manufacture. The special sub-committee, having thoroughly investigated the question, came to the decision that the

project should be abandoned in view of the difficulties that would be encountered from the factory and design aspect, and the great expense involved. Although a number of Mark V rifles were made for trial by troops, the weapon was never officially introduced in the British Service and was eventually abandoned for a new design, which became the Mark VI.

On 14th December, 1923, the Rifle Sub-committee recommended a new design with a heavier barrel, lighter nose-cap, and other modifications. On 31st July, 1924, two samples were on view to students of the Senior Officers' School, who were attending a demonstration at the Small Arms School, Hythe. These two rifles embodied the following features:

The barrel was about half a pound heavier than that of the Marks III and V, and was really the Long Lee-Enfield barrel of Short Lee-Enfield length. It was provided with special "L"-shaped lugs for attachment of a grenade discharger, and an additional pair of plain lugs for accommodating a block band foresight.

The body was on the lines of the Mark V rifle, but had been reduced in weight and bulk by re-design of the charger-guide and sight bracket elements.

The bolt differed from that of the Mark V in that the striker was made in two pieces, with the cocking-piece, which was of more compact design and had a reduced protrusion when cocked, integral with the rear portion. The bolt-head was more compact, had a single arm spring, and was controlled in the body by an internal rib and claw.

The stock was lengthened by .5 in. and fore-end and hand-guards redesigned.

A new design of *Keeper-plate* was embodied, with ears intended to strengthen the weak zone of the fore-end.

The foresight blade was undercut, to improve definition, and could be removed or adjusted by means of a special key.

The backsight was of the folding double-aperture type without wind adjustment, but with fine and coarse adjustments for elevation.

This was the first design of the Mark VI rifle, and it followed closely the established S.M.L.E. pattern. It was considered to retain the best features of the Mark III as a general service arm, be up-to-date in the light of recent war experience, and, in the event of a national emergency rising during the re-armament period, would cause no dislocation or abnormal changes in standard manufacturing methods and machinery. In order to meet those requirements it had been necessary to:

- (a) Employ a stiffened barrel, improving accuracy and rendering the weapon suitable for sniping, and replacing the Pattern 14 Rifle in that capacity.

- (b) Use a smaller and lighter nose-cap, and an exposed muzzle for securing the bayonet.
- (c) Re-introduce the principle of exposed muzzle with solid lug fittings for definite and rapid attachment and removal of grenade discharger.
- (d) Provide a body and bolt-head on S.M.L.E. lines, but of more compact and cleaner design, in order to save weight and to reduce the liability to catch clothing and equipment in drill and during bayonet fighting.
- (e) Improve the right hand grasp and minimize injury to hands during bayonet fighting by increasing the length of the "small" of the butt, and reducing the projection of the cocking-piece.
- (f) Provide an aperture backsight and maximum sight radius in order to simplify and regularize the method of aim, and increase accuracy at the target and in the field. Provide a fixed battle-sight for ranges up to 400 yards.

Full reports on these sample weapons were received by the Rifle Sub-committee, who eventually recommended that they should be modified in the following particulars:

Backsight. A plain slide with aperture, adjusted by rapid screw elevation and provided with a "clicker" device if possible.

Cocking-piece. A small knob, or button, to be fitted, to close the groove in the fired position and protect the hand when bayonet fighting.

Bolt-head to be capable of being easily released by the fingers.

Bayonet. The rifle to take the 1907 pattern bayonet.

Stock fore-end to be chequered to improve hand grip.

Butt-plate to be chequered.

By 1924 the pattern of the new British Rifle was moving towards finalization.

The provision of a new design of bayonet for the new British Service rifle was also under consideration and, in view of a bayonet's effect on barrel vibrations, it was necessary to come to an early decision as regards weight, length, and method of attachment to the rifle. A report from the Small Arms School dated 2nd October, 1924, gives a good picture of the requirement from the user angle. The report was as follows:

"It is generally agreed that the present long bayonet is far from being an ideal weapon owing to its length, weight and shape. The reason for its adoption seems to have been:

(a) Length. When the rifle was shortened it apparently was thought that a long bayonet should be attached so that 'reach' should not be sacrificed. The 'spirit of the pike' was still alive.

(b) Shape. It seems to have appeared desirable to the authorities that the bayonet should, when off the rifle, take the form of a

cutlass or dagger, both for offensive reasons and as a means of clearing brushwood, etc. The peculiar shape of the blade is rendered necessary owing to its great length, and to reduce weight without unduly sacrificing stiffness.

To criticize these reasons in order:

(a) It has been conclusively proved during the war, and since, with our present system of training in the bayonet, that 'reach' is not a main factor but that 'handiness' is. A man with a short handy weapon will beat an equally skilled man with a longer cumbersome weapon practically every time. As regards length of blade for killing purposes, the Physical Training Staff went into this in considerable detail during the war, and came to the conclusion that a 6-in. blade was sufficiently long to deal with the most thickly clad of our enemies—potential or otherwise. The most thickly clad was taken as being a Russian in winter clothing.

(b) In the war the utility of the bayonet as a cutlass or dagger proved to be negligible, hence the demand for trench knives, clubs, etc. As a means of clearing brushwood, etc., it is one of the most futile instruments imaginable. Even for cutting up duckboards and ammunition boxes for firewood it was ineffective, and it generally suffered severely in the contest. As a poker it was excellent, but this will apply to any form of bayonet. The handle form necessitated a two-point method of attachment to the rifle; thus a heavy nose-cap was required, which further increased the unhandiness of the rifle for bayonet fighting and shooting—particularly snapshooting. The difference in average scoring capability is estimated as being from 10 to 20 per cent lower in the case of troops who fire with the bayonet fixed. It is not so much the amount that the bayonet affects the actual shooting of the rifle that matters, as the great unhandiness in snapshooting and rapid fire, and the additional surface exposed to wind pressure in gusty winds. The long broad blade glints, even in moonlight and when 'Verrey' lights are fired. As a killing shape it makes a very nasty wound, but is of a bad section for penetration and worse for withdrawal. Owing to its great length and the leverage exerted it frequently breaks or bends, even against straw-filled sacks and in spite of being kept properly sharpened.

(c) The bayonet suggested for future adoption on the Mark VI rifle is one of about 8 inches in length, cruciform in section, and without the useless handle and cross-piece. The weight would probably be not more than half that of the present bayonet, and it is expected that the shape of the blade will be excellent for penetration and withdrawal. It will be inconspicuous, and the cruciform section will present no large plane surfaces for reflection of light. It should be attached to the muzzle of the rifle only by means of the same lugs which will be used to secure the grenade discharger cup. This method of attachment will have the advantage that the weight of

bayonet and in muzzle of rifle will be materially less. The handle and pommel of the present type of bayonet will be discarded, a light nose-cap can be used, and no separate standard or catch on the fore-end of the rifle will be necessary. The bayonet will be attached to the strongest part of the rifle, i.e. the barrel, and not partly to the comparatively weak wooden fore-end. The nose-cap can be brought forward, just including the foresight; the advantage of this, and the disadvantages of fitting the present bayonet are:

- (i) If a handled bayonet is used, the length of the handle requires the back attachment to be some $4\frac{1}{2}$ inches from the muzzle-end. This necessitates a nose-cap extending backwards, or a forward nose-cap with a long rear fitting for the bayonet, or with a long tang back to the catch. All these make for considerable weight. With a ring bayonet a light nose-cap, just including the foresight, can be used.
- (ii) The foresight protectors can be integral with the nose-cap, and the block band foresight can be reduced in size and weight.
- (iii) There will be a minimum of hot barrel to burn the user's hand in bayonet work after rapid fire."

The report from the Small Arms School found favour and it was considered that the suggested type of bayonet would be easier to manufacture, workmanlike in appearance, and would not detract from the spectacular effect of troops marching with fixed bayonets on ceremonial occasions. The principle of the "spike" bayonet was approved, and the handled sword bayonet seemed destined to disappear from the British Service.

In July, 1925, a number of "spike" bayonets (Fig. 10), fitted to Mark VI rifles, were submitted to exhaustive tests at the Small Arms School, Hythe. The first tests were carried out against sacks filled with straw lying on the ground, representing an enemy, the ground being fairly hard at the time. Thrusts were made at the artificial enemy and the bayonets were driven well and truly through the sacks into the ground. The new bayonet came through the tests well and showed no signs of bending. Further tests included parries, bayonet *v.* bayonet, bayonet *v.* sabre, etc., and the results were very favourable for the "spike" weapon. A number of tests were then carried out on the carcass of an old ewe. The sheep was shot and immediately dressed in an old canvas jacket to represent a shirt, and an old S.D. jacket and full equipment was then put on, with seventy rounds of dummy ammunition in the pouches. The carcass was suspended by ropes from a bayonet-fighting gallows and the hind legs were secured to the ground to offer greater resistance. It was still warm, with twitching muscles, when the tests were made. Points were made against the breast and stomach and good pene-

tration was made in almost every case. No difficulty was experienced in withdrawal. Numerous other points and jabs were made at the carcass and at different sections of the equipment and no damage was sustained by either rifles or bayonets. The new bayonet proved itself an extremely efficient weapon. It was light, handy, and easily manipulated, and it was considered that its advantages more than outweighed its loss of "reach". Three months later further tests confirmed the bayonet's capabilities.

The question of whether the Mark VI rifle "compensated" in the same manner as its predecessors was the subject of trials which, unfortunately, were never brought to a definite conclusion. When a

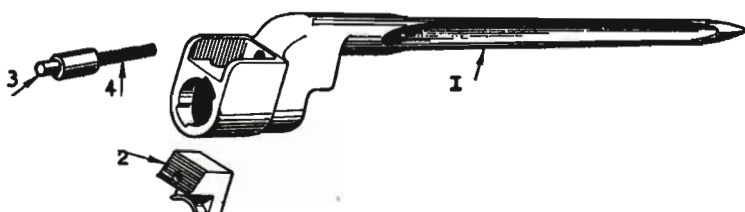

The New Spike Bayonet which became the No. 4 Bayonet, Mark I.

- | | |
|-----------------------|--------------------|
| 1. Blade (Cruciform). | 3. Catch Plunger. |
| 2. Catch. | 4. Plunger Spring. |

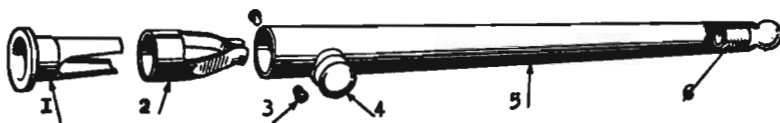

The No. 4 Bayonet, Mark I, Scabbard.

- | | |
|-----------------------|----------------|
| 1. Mouthpiece. | 4. Stud. |
| 2. Mouthpiece spring. | 5. Body tube. |
| 3. Mouthpiece screw. | 6. Body liner. |

FIG. 10. *No. 4 Bayonet, Mark I and Scabbard.*

rifle is fired, the barrel vibrates in both the vertical and horizontal planes, the vibrations being largely due to friction between barrel and bullet. A rifle is said to "compensate" when, due to the barrel vibrations in the vertical plane, bullets of higher velocity leave the muzzle on a lower line of departure, and those of lower velocity leave on a higher line of departure. The distance at which the trajectories of the two bullets will cross is called the "compensating range" of the weapon.

The following quotation from the Text Book of Small Arms, by permission of the Controller of Her Majesty's Stationery Office, describes the "compensation" of the earlier Lee-Enfield Rifle: "The

Lee-Enfield Rifle barrel vibrates in such a manner as to reduce the differences in height between the points of mean impact of ammunition with different velocities. For example, a Lee-Enfield Rifle fired with ammunition giving 2,235-f.s. velocity, shoots 12 ins. lower at 200 yards than with ammunition giving 2,000-f.s. velocity. At 390 yards range the points of impact with both classes of ammunition are at the same height. At 1,000 yards the 2,235-f.s. ammunition shoots 7 ft. higher than the other. We see, therefore, that the bullets of the high velocity ammunition leave the barrel when the muzzle is at a much lower point in its curve of vibration, and therefore shoot low at 200 yards, but their trajectory being flatter than that of the 2,000-f.s. ammunition, it crosses the trajectory of the latter at 390 yards range, and keeps above it at all other ranges. In designing a new rifle endeavour should be made to so arrange the length of the barrel, the strength and weight of the parts, and the method by which the recoil of the barrel and body is communicated to the stock, so that the barrel is in the middle of an upward vibration when a bullet with normal velocity leaves the muzzle; for then a bullet with higher velocity will leave the muzzle when it is pointing lower; and a similar compensation to that which occurs in the Lee-Enfield Rifle will take place."

The trials which took place in September, 1924, were with two Mark VI rifles and Mark VII ammunition loaded with different charges. Velocity measurements of the two rifles were as follows:

<i>Charge</i>	<i>Observed velocity at 60° F.</i>	
	<i>Rifle "A"</i>	<i>Rifle "B"</i>
33, 5-2 grains	2,142	2,141
34 " " " "	2,239	2,236
35 " " " "	2,313	2,210
36 " " " "	2,379	2,379
36½ " " " "	2,406	2,422
37 " " " "	2,442	2,467
38 " " " "	2,505	2,509

It will be seen that, except in the cases of the 36½ and 37-grain charges, the results were practically identical. It was thought that the difference in those two charges was probably a question of abnormality of individual rounds, and, from the average of the remainder of the two columns, it was assumed that the two rifles shot to the same velocities. The 36-grain charge corresponded to the specification observed velocity. Groups of three shots were fired

from the shoulder from each rifle with each batch of ammunition, at a range of 72 ft. 4 in.* The heights of the average points of mean impact of each group above the point of aim were as follows:

<i>Charge</i>	<i>Rifle "A"</i>	<i>Rifle "B"</i>
33 grains	3·7 in.	4·4 in.
33 "	3·4 "	3·7 "
35 "	3·0 "	3·3 "
36 "	2·35 "	3·15 "
36½ "	2·1 "	2·8 "
37 "	2·0 "	2·6 "
38 "	2·2 "	2·35 "

From these figures the comparative jump,† in minutes, at each observed velocity worked out as follows:

<i>Observed velocity</i>	<i>Rifle "A"</i>	<i>Rifle "B"</i>
2,141 f.s.	14·8	17·6
2,237 "	13·6	14·8
2,311 "	12·0	14·2
2,379 "	9·4	12·6
2,414 "	8·4	11·2
2,454 "	8·0	10·4
2,507 "	8·8	9·4

It will be seen that, although the "jump" was less with increased velocity throughout the whole range in the case of Rifle "B", there was a tendency for the "jump" of Rifle "A" to increase at the highest velocities (i.e. between 2,454 and 2,507 f.s.). Thus it was considered that with Rifle "A", high velocity shots were not compensated, except at very short range. In addition, both curves showed a hump, in the case of Rifle "A" at about velocity 2,280 f.s. and Rifle "B" at about 2,350 f.s. These humps were considered to have been probably due to errors in shooting or measurement, or may have indicated the presence of a harmonic‡ (or overtone) affecting barrel vibrations. A small re-shoot indicated that they

* At 71 feet 4 inches. ¼ inch on the target = 1 minute of angle.

† The angle of "jump" is the angle made by the line of departure of the bullet and the axis of the rifle before firing. (The axis of the rifle is the straight line through the centre of the bore.)

‡ A harmonic is a disturbance of the natural vibrations.

were genuine harmonics, but in the time available it was not possible to confirm this definitely. It was considered that such harmonics would have the effect of increasing the compensation range for shots whose velocity did not vary much from the normal. For shots of a rather lower velocity the compensation range would be reduced, and there would thus be no very definite range at which the elevation required for ammunition of varying velocities would be constant. Ignoring these humps, however, the results indicated that for Rifle "A" the compensation range was about 875 yards and for Rifle "B" about 800 yards.

A small re-check shoot was then carried out at 600 yards range using mixed ammunition and, as far as could be seen, confirmed these figures without establishing any definite compensation point. Some attempt was made to ascertain whether an increase of weight at the muzzle had any effect on the compensation range and, for this purpose, a weight was attached by wire. The test was unsuccessful, as it was found that the weight shook loose with the vibration of the barrel and time did not permit for further investigation in this direction. To obtain the best results a normal round should leave the muzzle about mid-point of the rising vibration. In the case of both rifles there were indications that the normal round was leaving somewhere near the bottom of the vibration, and consequently a slightly faster period of vibration was expected to effect an improvement. As the compensation range appeared to be somewhat on the long side, it was considered that less amplitude of vibration would also be advantageous. It was thought that a faster vibration, and of less amplitude, could be obtained by a slight increase in the stiffness of the barrel, and that speed could probably be further increased by reducing the weight of the nose-cap. It was believed that in order to obtain really good compensation, any harmonics such as those suspected to exist would have to be eliminated. It had been proposed to move the nose-cap of the rifle nearer to the muzzle and it was thought that if this was done it might remove the harmonics. Unfortunately no further action appears to have been taken in the matter and, in view of the many small changes which were made before the rifle went into production, it is doubtful whether the results of these limited trials can be regarded as any guide to its ultimate degree of compensation. There are no records of any further compensation trials having taken place.

After the Second World War, a programme was drawn up for a compensation trial with the No. 4 Rifle to take place on C.I.A.'s Proof Range at Woolwich Arsenal, but official approval was not forthcoming and the project was eventually dropped.

CHAPTER XIII

DEVELOPMENT AND INTRODUCTION OF THE NO. 4 RIFLE

EARLY in 1926, six prototype models of the proposed Mark VI rifle were manufactured for preliminary trials. A great deal of consideration and thought had been put into the design and production of these weapons, involving very close liaison between the responsible officers representing design, production, inspection and user. The more important details of the six trial weapons were: *The body* was redesigned and the vital sections strengthened. The charger-guide brackets were formed integral with the body, in the interests of economy and compactness. The area of the rear axis lugs had been increased, with the object of improving accuracy. A new design of bolt-retaining catch had been embodied which eliminated the use of force and risk of injury to the hands in operation.

The barrel was stiffer than in the earlier Marks of Lee-Enfield rifles. The front face of the muzzle was cut square instead of being radiused, in order to better sustain the thrust of the discharger cup in grenade firing. The barrel weighed 2 lb. 8½ oz. (5½ oz. heavier than the Mark III) and was provided with lugs for the attachment of bayonet and cup discharger. Details of bore and chamber remained unaltered.

The bolt had resistance areas of equal width on lug and rib. The rib was lightened and the knob of the bolt-lever hollowed in the interests of both gross and outhung weight. The bolt-head was more compact than previous patterns and worked on an inside rib in the bolt-way, with the advantages of weight, bulk and cross-cornering action in extraction. The basic principle of this bolt-head was an expired B.S.A. patent. The cocking-piece had a plain button end, and a reduced cocked projection, and was provided with a transverse striker keeper-screw.

The foresight was housed in a block band which encircled the barrel. The blade was rectangular and undercut, and lateral adjustment was controlled by a tamper-proof screw.

The backsight was of an entirely new design. It was housed low on the centre line and well supported to resist injury. The leaf was retained in the usual three positions by a ball plunger. The slide

was box section with a long bearing surface. Elevation was obtained by means of a quick-acting screw with floating nut. The large head permitted easy elevation setting with a single finger, with the leaf in any of the three positions (horizontal, vertical or half-way). Clicker device was incorporated, each click representing 25 yards in the 500-yard zone. The battle-sight was integral with the leaf, of particularly sturdy section, and did not foul the cavalry rifle bucket.

The nose-cap had been reduced as much as possible but was subject to no stress.

The stocking. The fore-end was provided with ample bearing surfaces in the essential places, and the keeper-plate had been discarded in favour of a spring washer in the butt. A tie-piece strengthened the socket end. The fore-end was square chequered and the hand-guard had longitudinal lines to improve the hand grip. A housing ring at the rear of the rear hand-guard replaced the spring clip.

The butt-plate was made of the usual material with the centre zone square chequered. The chequered zone was protected to some extent by the curvature of the plate and the screw-heads.

Preliminary shooting tests were carried out at Enfield with and without the bayonet fixed. It was noted that there was a tendency for the rifles to group closer with the bayonet on, and accuracy improved as the barrels warmed up. The effect of the bayonet was also to bring down the mean point of impact of the groups by about 9 minutes of angle. Equivalent weights to that of the bayonet when fastened firmly to the muzzle of the rifle produced similar results but, when the same weights were suspended loosely from the muzzle, the effect was negligible. In July, four of the rifles were sent to the Small Arms School for further trials, from which they emerged successfully. The effect of the bayonet on mean point of impact found at Enfield was confirmed in these trials.

Later in the year Service trials were carried out with the object of discovering the new rifle's capabilities as compared with the Mark III, and to consider its design from the point of view of the soldier on active service. As a result of these trials the following comments on points affecting mechanism and design were considered by the Small Arms Committee:

The butt-plate. The chequering was considered to be of no appreciable advantage.

The butt-trap opened too easily. With the oil bottle inside, a vigorous movement of the rifle caused the bottle to force open the lid of the trap and fall out. A stiffer butt-trap spring was suggested to remedy this defect.

The pistol grip was considered to be too far from the trigger.

The locking-bolt was found difficult to press forward and a slightly larger knob was suggested.

Cocking-piece. The mushroom-shaped head was well liked and was

considered to lessen the chances of injury to the hand during bayonet fighting.

The cut-off. The "stop" on the rear end was found to be very sharp. *Bolt* manipulation was found to be much smoother with the new design of bolt-head.

Backsight. The milled head for elevation adjustment was found to move too easily. After the sight had been adjusted for a required distance, an accidental touch occasionally moved the screw and disturbed the setting. A varying number of turns was required to move the sight for each hundred yards and this was considered to negative any benefit obtained from the screw being made to "click" at every quarter-turn. It was suggested that the milled head should be made harder to turn, and that each "click", or turn of the head, should raise elevation by the same amount, at any rate up to 600 yards. The range marks on the leaf and the synchronizing line on the slide should be more clearly defined. Suggestions were also made to render the backsight less liable to damage and misuse.

Fore-end. The chequering was considered to be useful.

Foresight. It was suggested that the foresight bed should be reduced in width to the same size as on the Mark III rifle. It could then be used in the "Degree method" of "Indication and Recognition of Targets".

Foresight protectors. For the purpose of measuring degrees in visual training, they were required to be narrower.

Muzzle. Owing to the protruding muzzle great care was found to be necessary to avoid picking up obstructions.

The bayonet was considered more difficult to fix, but easier to unfix, than on the Mark III rifle. Bayonet fighting was found to be appreciably easier in many ways, but control of the "point" was more difficult. This was due to the point of balance of the rifle with the bayonet fixed being too near to the butt. It was found to offer far less wind resistance than the long sword bayonet and shooting was less affected.

The many criticisms were carefully studied and modifications were eventually recommended on the following points:

1. It was decided to abandon the chequering on the butt-plate.
2. The backsight adjustment to be arranged to give a constant rise of 2 ins. per 100 yards, and the battle-sight fixed to give 400 yards elevation with the bayonet fixed.
3. Chequering on fore-end to be retained.

Another important cause of numerous trials and investigations was the barrel vibrations of the new rifle. In this connection, great efforts were made to find the means, without a radical change in design, of decreasing the effect of the bayonet on shooting. Various methods of stocking-up were tried. The barrel was clamped to the

fore-end by forcing it upwards against the nose-cap by a wedge under the barrel. In another method, a packing-piece was placed between stock fore-end and barrel, a band round both keeping them in close contact. None of these methods produced very satisfactory results, and it was generally agreed that the only way to effect the desired improvements by lessening the barrel vibrations would be to redesign the action. This course was out of the question as the action had already been approved and was in production. With the Lee-Enfield type of rear locking bolt considerable bending of the action occurred when the rifle was fired and this impulsive bending had an effect on, even if it was not the main cause of, the vibrations of the barrel. Further experiments were made with a Mark VI barrel fitted to an action with front locking lugs. A Pattern 1914 Enfield action, with an adapter for a Mark VI barrel, was fitted in a Pattern 1914 Enfield stock which had the fore-end sawn off just in front of the chamber. The barrel was thus free to vibrate and the vibrations were found to have completely altered. The movements were very small until after bullet exit, and bore a marked resemblance to those of a Pattern 1914 rifle barrel in its own action, when stripped of all woodwork. The accuracy was very good and, at the short range at which the tests were carried out, more than equalled that of the Pattern 1914 Sniper Rifle. With the barrel loaded with an 8 oz. weight, little difference was found in the vibrations, and it was considered that accuracy would be little affected by fixing the bayonet since it made no appreciable difference to the "jump". The conclusion reached as a result of the trials was that if the Mark VI barrel was used with the existing design of action, the effect of the bayonet could be slightly lessened by attaching the barrel to the stock fore-end, though the difference would be very small. There were, however, disadvantages in attaching the barrel which were considered to outweigh any slight improvement that might be made. By re-designing the action it was thought possible to reduce the vibrations so that the rifle shot accurately at short ranges and the effect of the bayonet would be eliminated. It was considered that compensation for a long range appeared to necessitate somewhat vigorous vibrations and, with a rifle so compensated, the bayonet must always affect the "jump". If it were possible to control and alter vibrations at will, a satisfactory compromise between compensation range and effect of bayonet might be effected. Further trials were recommended.

In May, 1926, a new system of nomenclature was introduced in the British Service and the Short Magazine Lee-Enfield Rifle, Mark III, became the RIFLE No. 1, MARK III. The Mark VI eventually became the RIFLE No. 4 and, by 1930, it had emerged with considerable success from many technical trials, with better

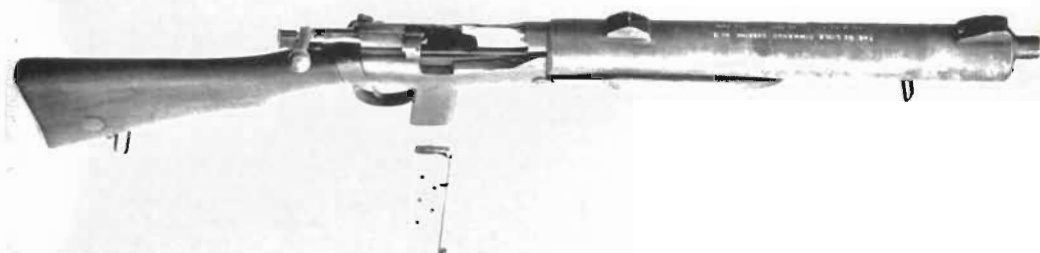

WORLD WAR II OPPONENTS

Top: German 7.92 mm. F.G. 42 Automatic Rifle as used in Crete by German Parachutists.
Bottom: The De Lisle Carbine, a near relation of the Lee-Enfield family. It was developed secretly during World War II for the British Commandos. The body, action (with shortened bolt) and butt were those of the No. 1 Rifle (S.M.L.E.) Mark 3*. It fired a cartridge of .45-in. calibre.

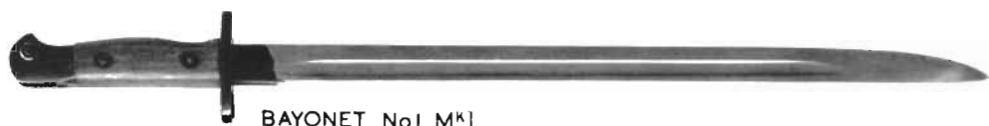

BAYONET No 1 Mk 1



No 3. Mk 1.



No 4. Mk 1



No 4. Mk 2



No 4. Mk 2 *



No 4 Mk 3



No 5. Mk 1



No 7. Mk 1



No 9. Mk 1

BRITISH BAYONETS

No. 1 for No. 1 (S.M.L.E.) Rifle.

No. 3 for No. 3 (Patt. 1914) Rifle.

No. 4 for No. 4 Rifle.

No. 5 for No. 5 Rifle and L2 A3 9mm. Sub-machine-gun.

No. 7 for Mark V Sten M/c Carbine.

No. 9 for No. 4 Rifle and M/c Carbine.

accuracy than that of the British Service weapon. To confirm these results, troop trials now had to be arranged and, although the rifle had not yet been officially introduced, its manufacture had commenced at the Royal Small Arms Factory at Enfield. It was expected to have the first 500 rifles available for trials by May, 1931, and a further 500 by the middle of June of that year. It was suggested that the rifles should be issued to an Infantry battalion and a Cavalry regiment, to carry out a special musketry course and spend all the summer training with them, and they were eventually issued to the 2nd Bn. The West Yorks Regt., and the 3rd Carabineers, and a small number to the Small Arms School. The conclusion arrived at as a result of these trials was that, apart from manufacturing advantages, the new rifle was in many respects an improvement on the Service arm and its adoption would lead to a better standard of marksmanship in the Services. This conclusion was based on its handiness, the greater accuracy of its heavier barrel, and the ease of teaching the use of the aperture sight. Several small defects were noted and modifications were proposed to eradicate them. Difficulties had been experienced with the first run-of-work rifles in getting them to shoot accurately. The inaccuracy was always in the vertical plane, the lateral angle being very good, and the cause was eventually traced to the body. The design of this had now been modified, and the weapon shot with consistent accuracy.

In 1932, further trials were commenced in Aldershot, Eastern and Northern Commands and Egypt, and arrangements made for a trial in India. In 1935, twelve rifles embodying certain of the suggested modifications were sent to Hythe, where comparative shooting trials were carried out with a similar number of Service Mark III rifles. The trials showed that the modifications had apparently fulfilled their purpose. The rifles were more accurate, but the effect of the bayonet was still considerably greater than with the Service weapon. The special practices which were fired for comparison of accuracy produced the following results:

	<i>No. 4 Rifle</i>	<i>S.M.L.E. Mark III</i>
	per cent	per cent
Deliberate	85·1	83·25
Gas	90·0	68·75
Rapid	79·8	73·9
Snapshotting	82·5	76·6
Fire with movement ..	78·0	75·5

Official approval for the manufacture of the No. 4 RIFLE, MARK I, and its ancillary stores was announced on 15th November, 1939. Particulars of the new British Service rifle were as follows:

<i>Weight</i> (without bayonet)	9 lb. 1 oz.
„ (with bayonet)	9 lb. 8 oz.
<i>Length</i> (without bayonet)	44.43 in.
„ (with bayonet)	52.79 in.
<i>Barrel.</i> Bore303 in.
Rifling, form	concentric
Number of grooves	5
Direction of spiral	Left-hand
Pitch	1 turn in 10 in.
Depth of grooves005 in.
Width „ „0936 in.
Chambered for303-in. rimmed cartridge.
<i>Magazine</i> —Capacity	10 rounds
Weight (filled)	14 $\frac{3}{4}$ oz.
„ (empty)	5 $\frac{3}{4}$ oz.
<i>Sight radius</i>	28.72 in.

The rifle was similar to its predecessor, the No. 1 or S.M.L.E., the only radical departure in design being in the method of sighting, the new arm having an aperture backsight hinged at the rear of the body. The heavy nose-cap of the No. 1 rifle was abolished, the barrel being exposed for approximately 3 in. at the muzzle end. All screw threads were to standard specifications and the majority of the components were not interchangeable with those of the No. 1 Rifle, in which the Enfield form thread was largely used. The following details of the principal parts show how the new pattern differed from the No. 1, Mark III Rifle:

The barrel was the same length, but the external diameter was larger. Solid lugs were provided at the muzzle end for fixing the bayonet and the foresight block band.

The lower band was approximately .5 in. wide. An alternative design was also approved. This differed only in that the lugs which house the clamping screw were manufactured separately and welded to the band.

The upper band was approximately 1 in. wide and was hinged at the top for ease of fitting. It was assembled at the front end, over the front hand-guard and stock fore-end. An alternative design was approved which was not hinged, and the lugs were made separately and afterwards welded to the band.

The foresight band block was slotted from the forward end of the dovetail to the foresight protector screw hole, to act as a clamp for the foresight blade.

The foresight blade screw-head was formed to take a special tool to prevent unauthorized adjustment.

The breech-bolt rib was wider and had a longitudinal lightening groove. The bolt-head tenon hole had a plain portion for approximately $\frac{3}{8}$ (three-eighths) in.

The body rib-way, or bolt-head guide, was formed with an inner undercut ledge which ensured more effective control of the bolt-head. The sides of the charger-guide were formed solid with the body and were connected by a bridge piece. Side ears were formed at the rear end and were drilled transversely for the backsight axis pin. A "T"-shaped guide groove was cut on the right side to house a new type of bolt-head catch.

The breech bolt-head wing was shorter and grooved to engage the undercut ledge on the body. Four different lengths of bolt-head were provided, Nos. 0, 1, 2 and 3. They progressed by increments of .003 in. respectively and were provided for ease of head-space adjustment.

The breech-bolt catch was "T"-shaped, and had a thumb-piece at the top formed with a tongue to engage the breech-bolt-head groove. The rear face had a radial groove to house a small coil-spring.

The breech-bolt-head catch plate was "L"-shaped, the long arm having a tapped hole. It was retained to the body by the magazine catch screw.

The backsight consisted of a leaf, slide, nut, adjusting screw, retaining pin, plunger and spring. The leaf was graduated in increments of 50 yards. A battle-sight (or fixed sight) was provided on the rear face for use when the leaf was down in the horizontal position. The leaf was retained in the upright position by a spring-loaded plunger located underneath in a hole in the body. The slide, finely chequered on the rear face, was controlled by an adjusting screw which passed through a detachable nut. Rotating the screw in a clockwise direction raised the slide, and consequently the elevation. The aperture, through which the sights were aligned, was in the slide, and was .10 in. in diameter. The adjusting screw was approximately $1\frac{3}{4}$ in. long and had a fixed knurled head. It was retained in the leaf by a lateral pin. The plunger and spring, housed at the top of the leaf, acted on serrations beneath the head of the adjusting screw to form a clicker device.

The butt-plate trap differed in that the lip was omitted and it was provided with a transverse pin. The pin rotated in the butt-plate recess and the trap was retained by a spring.

The cocking-piece had a dome-shaped head.

The locking-bolt thumb-piece was longer and had a radial head.

The locking-bolt spring had a square boss with projections for positioning in a groove in the left of the body forward of the butt socket.

The magazine catch tail was altered in "set", and projected at a different angle into the bow of the trigger-guard.

The magazine case was modified to suit its central location in the body. The rib on the rear face did not extend beyond the catch ledge, and the rib spring was omitted (Fig. 11).

The magazine platform was altered in contour to facilitate manufacture, and could be identified by the sharper taper and wider turned-over lip at the forward end.

The magazine platform-spring was approximately the same length but the turned-over end was not a full radius. It had a round hole, in lieu of a slot, for fitting the rib of the case.

The foresight protector was similar to that fitted to the Pattern 14 Rifle (re-named the No. 3 Rifle). It was assembled around the foresight block band and partially engaged with the lugs on the barrel, a transverse screw locking it in position. An alternative design had been approved which differed mainly in method of

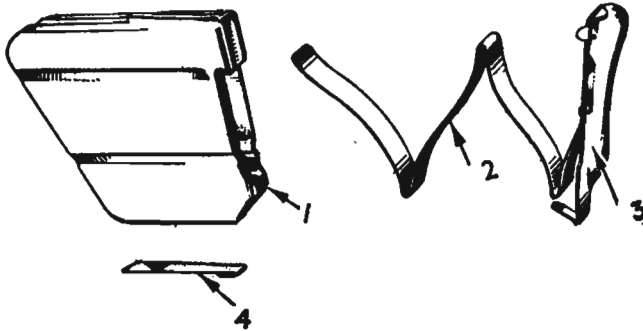

FIG. 11. No. 4 Rifle, Mark I, Magazine.

1. Magazine case.

2. Spring.

3. Platform.

4. Auxiliary spring.

manufacture; a plain hole being bored, eliminating the interruptions for engaging the lugs on the barrel (Fig. 12).

The stock fore-end was provided with a cap, approximately $2\frac{1}{4}$ in. long, at the forward end, and a tie-plate was fitted instead of a screwed pin. The barrel groove was recessed for purposes of lightening.

The front and rear hand-guards were similar to those fitted to the Pattern 14 rifle. The front guard was fitted with a cap, approximately $2\frac{1}{4}$ in. long, and two liners. The rear hand-guard had one liner and was retained in position by a ring encircling the rear end of the barrel.

The stock-bolt spring washer replaced the keeper-plate, and was inserted between the head of the stock-bolt and steel washer.

The bayonet fitted over the muzzle end of the rifle barrel and consisted of a blade, catch, plunger and spring. The blade was approximately 9 inches long. The Mark I pattern was cruciform in section and the Marks II and II* were circular spikes. All three tapered

to a point and were provided with a barrel socket at the rear end. The socket was offset approximately 1 inch from the blade and was approximately 2 inches long, being bored to assemble over the muzzle. The rear of the socket was recessed internally to engage the two lugs on the rifle barrel, and drilled and slotted externally to house the spring and catch. The catch was rectangular in shape, having a radial face and lip. It was drilled longitudinally to house

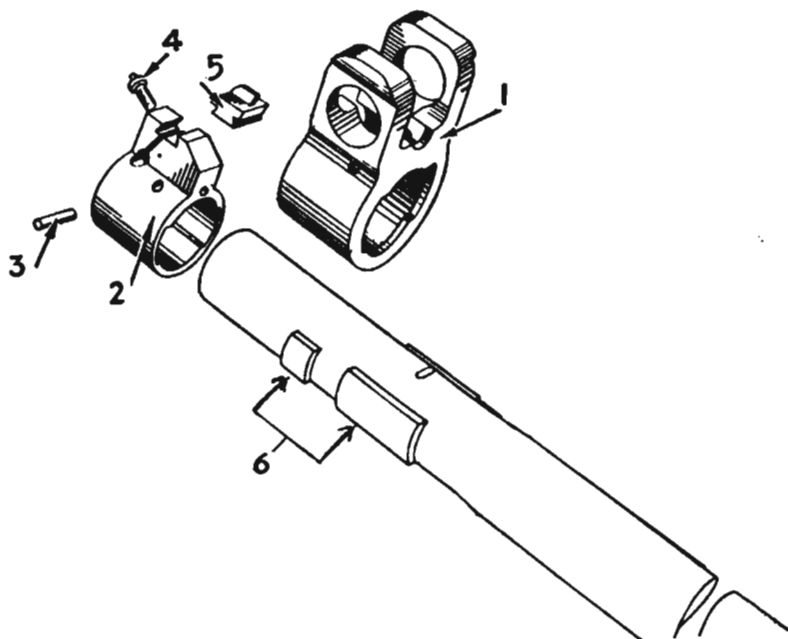

FIG. 12. No. 4 Rifle, Mark I: Block, Band, Foresight, Mark I.

- | | |
|---------------------------------|-----------------------------|
| 1. Foresight protector, Mark I. | 4. Foresight locking screw. |
| 2. Block, Mark I. | 5. Foresight blade. |
| 3. Block pin. | 6. Barrel lugs. |

the tail of the plunger, and the rear was serrated to assist manipulation. The plunger was cylindrical and approximately 1 inch in length. It was reduced in diameter at one end and bored from the opposite end to accommodate the coil spring. The main difference between the Mark II and the Mark II* bayonet was the method of manufacture. The Mark II was in one piece whereas the Mark II* was made in two parts, known as the spike and socket, which were finally brazed together.

The scabbard for the bayonet was a tapered steel tube. It was approximately 8 inches in length and had a cylindrical steel, or zinc base alloy mouthpiece, and a knob-shaped tip. A spring, fixed by two screws between the mouthpiece and tube, held the bayonet in

position. A leather liner was in the lower part of the tube to cushion the bayonet, and a stud was provided for attaching the scabbard to the frog on the belt (Fig. 13).

The Mark II and II* bayonets were easier to manufacture, but were not popular with the troops. On their introduction the Mark I was declared obsolescent and no more of this pattern were made until after the War.

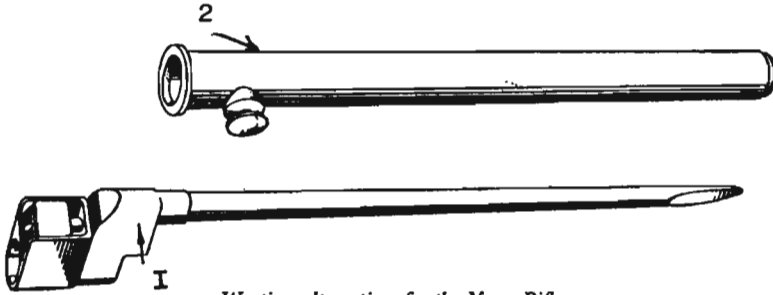

Wartime alternatives for the No. 4 Rifle.

FIG. 13. *Mark II Bayonet and Mark II Scabbard.*

1. Bayonet, Mark II.

2. Scabbard, Mark II.

The method of stocking-up the No. 4 Rifle differed considerably from that for the No. 1 Rifle, and the principal features were:

1. The stock fore-end fitted firmly at the rear end between the sear lugs and the face of the butt socket of the body.
2. It seated on the body surfaces around the front trigger-guard screw hole and extended rearwards along the narrow ledges on each side of the magazine opening for not less than $1\frac{1}{2}$ inches. The resistance of the body to the fore-end was equal on each side of the trigger-guard screw. There was a clearance between the barrel socket of the body and the fore-end on each side.
3. There was a firm bearing on the reinforce of the barrel, extending the full length of the reinforce and about one-third of its radius in width. It was important that the bearing was in the centre of the radial clearance of the fore-end and the sides of the barrel were entirely clear of the fore-end.
4. The barrel rested on the raised seating at the muzzle end of the fore-end. The bearing extended the full length of this seating, with the barrel positioned centrally and not biased to either side. The clearance on each side was not less than .02 in. and lift required to raise the barrel from its seating was between 3 and 5 lb. If the lift was below 3 lb., the bearing at the reinforce was lowered slightly and the collar on the front trigger-guard screw shortened if necessary. If the lift was above 5 lb. the bearing on the body seating was lowered, and the collar shortened if necessary.

5. It was necessary for the barrel to be entirely free from influence of the fore-end except at the points specified, and the clearance was about .05 in. The hand-guards were also clear of the barrel by the same amount, except at the muzzle end, where the clearance could be less providing the barrel was free.

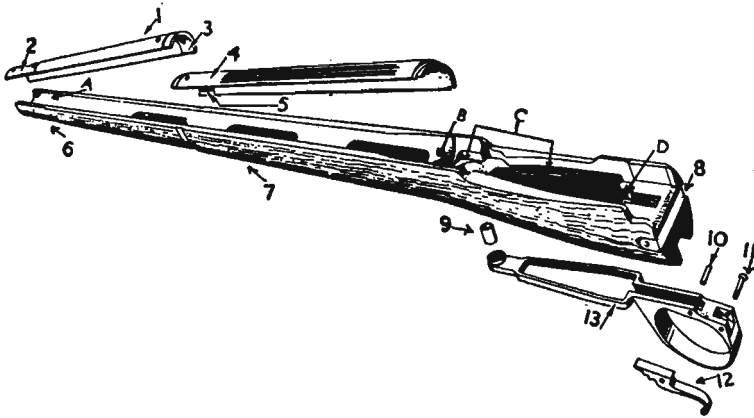

FIG. 14. *No. 4 Rifle, Mark I. Stocked.*

1. Front hand-guard.
2. Hand-guard cap.
3. Hand-guard liner.
4. Rear hand-guard.
5. Hand-guard liner.
6. Stock fore-end cap.
7. Stock fore-end.
8. Tie-plate.
9. Collar.
10. Trigger pin.
11. Trigger-guard rear screw.
12. Trigger.
13. Trigger-guard.

Where there should be good bearings in a correctly stocked-up rifle.

- A. Muzzle.
- B. Reinforce.
- C. Body seating.
- D. The draws (between sear lugs and socket face)

CHAPTER XIV

THE NO. 4 MARK I* RIFLE AND PROBLEMS OF WAR-TIME MANUFACTURE

ALTHOUGH not officially introduced through the British War Office List of Changes until 23rd November, 1946, the No. 4 RIFLE, MARK I*, had been in production in Canada and the United States since 1941. It was similar in design to the Mark I with the following exceptions:

1. A slot was cut in the body ribway, through which the bolt-head was released for dis-assembly. Machining for the bolt-head catch was omitted.
2. The bolt-head catch, and the spring and plate, were omitted.
3. A new pattern bridge-piece was incorporated in the body to permit removal of the bolt (Fig. 15).
4. The magazine catch screw was replaced by a pin, and the sear pin was increased in length.

Soon after the outbreak of war in 1939, it became evident that the industrial potential of Canada would eventually be fully developed in the interests of munitions production, and that assistance in this respect might ultimately be needed from the U.S.A. Eventually a Joint Inspection Board of the U.K. and Canada was set up to control inspection and administer finance on behalf of the two Governments. It had an Inspector-General, and a Deputy Inspector-General at Ottawa and one in New York, and held its first meeting on 15th November, 1940. A number of experienced technical officers from the U.K. joined the Board and the pooling of resources had much to do with the eventual high standard of Canadian produced weapons. A special Directorate of Inspection of Small Arms and Small Arms Ammunition was formed early in 1941 and included a number of officers from the Ministry of Supply and the Ministry of Aircraft Production from the U.K. The principal immediate problem in Canada was the organizing and planning, including development of adequate proof and experimental facilities, to meet the foreseeable vast expansion in S.A. and S.A.A. production. To meet

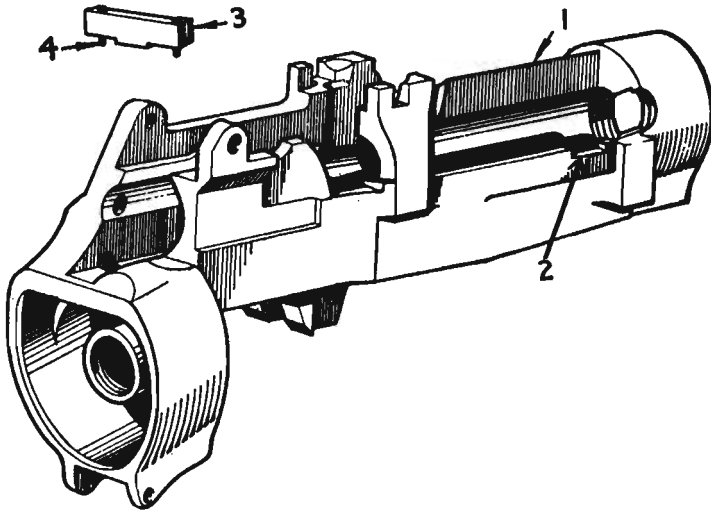
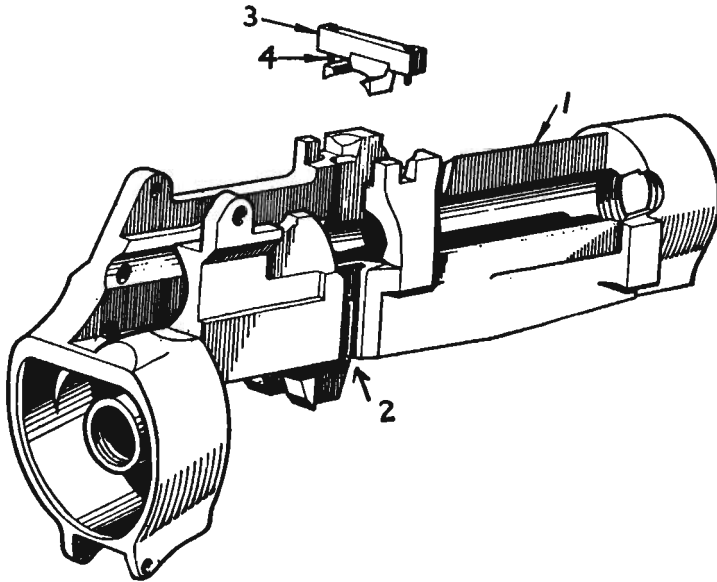

FIG. 15. How the body of the Mark I* Rifle differs from that of the Mark I. Mark II body as fitted to No. 4 Mark I* Rifle

- | | |
|--------------------|--------------------|
| 1. Body. | 3. Mark II Bridge. |
| 2. Slot in ribway. | 4. Bridge screw. |



Mark I Body (as fitted to No. 4 Mark I Rifle).

- | | |
|---------------------------------------|-------------------|
| 1. Body. | 3. Mark I Bridge. |
| 2. Machining for the bolt head catch. | 4. Bridge screw. |

the more acute problems in the U.S.A. the Directorate Headquarters was initially set up in Washington. Here there was a need for advisory services to the British Purchasing Commission, British Army Staff, and the British Air Commission in their technical negotiations with U.S. Ordnance, and in connection with the placing of orders with American manufacturers for British type small arms and small arms ammunition. With the implementation of the Lease Lend programme, British contracts were taken over in the U.S. and Directorate Headquarters moved to Ottawa.

It was at Long Branch, near Toronto, that the No. 4 Rifle, Mark I*, was manufactured; control of production, quality and corrective development being exercised through a special Small Arms Technical Committee. Nearly a million of these rifles, including about a thousand Sniper Equipments, were made during the war at this new factory. The rifles were all marked "Long Branch" on the left side of the body. The No. 7 .22-in. Rifle, described in Chapter XIX, was also made here.

In the U.S. over a million No. 4 Mark I* Rifles were made by the Savage Arms Company. This Company incorporated the Stevens Arms Company and, to distinguish weapons of Stevens manufacture, the letter "C" was included in their serial numbers. The "C" denoted Chicopee Falls, Mass., the location of the Stevens factory. All the No. 4 Rifles made in the U.S. were marked "U.S. Property" on the left side of the body, and they were the only ones to be fitted with barrels embodying six-grooved rifling. In 1942 a small number were converted at Enfield (U.K.) into Sniper Equipments.

When the No. 4 Rifle was put into mass production, it was practically divorced from the home of its predecessors, the Royal Small Arms Factory at Enfield Lock. For the needs of the British Army in World War II this factory was largely devoted to the manufacture of the Bren Light Machine-gun, and the necessary plant for production of the new rifle was established at three new Ordnance factories. These were at Maltby in Yorkshire, Fazakerley in Lancashire, and Shirley on the outskirts of Birmingham; the latter being under the control of the B.S.A. Company. A number of Enfield men, skilled in the manufacture of rifles, formed the nucleus of the staffs at Maltby and Fazakerley but, for the most part, early production was achieved by unskilled labour. Although the first few thousand rifles from the production lines left much to be desired, and compared most unfavourably with pre-war models, much praise is due to the factory staffs, and the Government inspectors who rendered untiring assistance, for eventually making a good weapon under very difficult circumstances. By June, 1941, 25 rifles had been made at Maltby, the following month Fazakerley had produced 300, and by August the Shirley factory had made a similar number.

Production figures steadily improved but many small changes had to be made to the original design to ease the problems of the manufacturers. Unfortunately the changes invariably lowered the standard of the weapon but, so great was the need for rifles, appearance and efficiency had to be temporarily sacrificed.

One of the first features to be discarded was the Mark I back-sight, a major "bottleneck" to production, and this was replaced by the Mark II dual battle-sight. This pivoted on an axis pin and had two small leaves in which were apertures, one being in the vertical position for use whilst the other was horizontal. One was marked

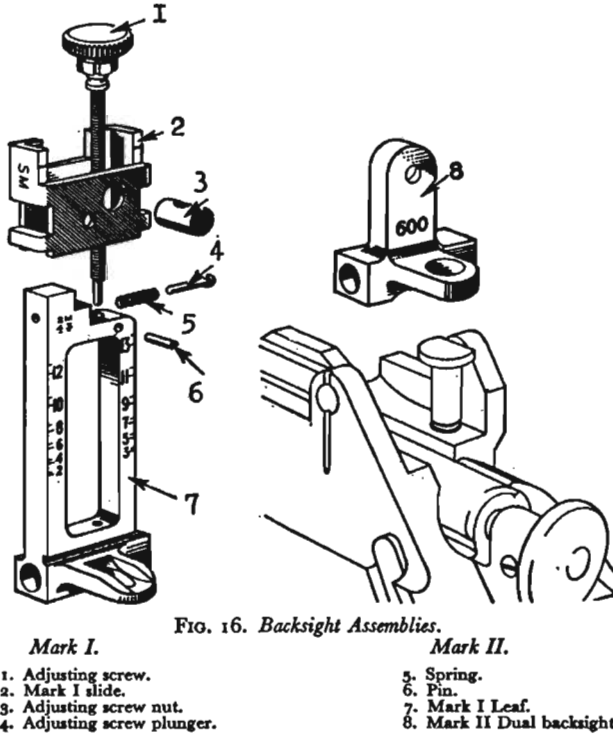

FIG. 16. Backsight Assemblies.

"300", for use at ranges up to 300 yards with the bayonet fixed, the other was marked "600" for use at that range without the bayonet. Intermediate ranges were not catered for on the sight and the firer had to use his own judgment in aiming up or down. It was a very crude sight but had to be introduced owing to lack of manufacturing facilities for the Mark I sight (see Fig. 16). It soon caused troubles in the Service in the matter of "zeroing" rifles. Rifles were zeroed in the factory without the bayonet and, as the bayonet's effect on shooting varied with differences in stocking-up, fit of bayonet on rifle, etc., there was no guarantee that the weapon could be correctly

zeroed in the Service with the bayonet. Efforts were now made to design a simplified tangent aperture backsight with adjustment for the various ranges, and which would be easy to manufacture.

In September, 1942, a sample sight made by the B.S.A. Company was shown to the Commandant, Small Arms School. This was made from pressed steel and comprised a leaf and slide with aperture. The slide was held in position at the desired range by a spring which engaged in serrations on the side of the leaf. It was very simple in construction and easy to produce. It was considered at the Small Arms School to be a great improvement over the Mark II Dual Sight and would obviate the existing zeroing difficulties with the No. 4 Rifle. The soldier would have a sight on his rifle which would enable him to engage targets at all battle ranges without having to calculate the amount he would have to aim up or down for intermediate ranges, and would dispense with the necessity of having bayonets fixed when engaging targets up to 300 yards. It was considered easier to learn and teach, and cheaper to produce, than the existing backsight. Meanwhile the Government Design Department had developed a similar type of pressed steel sight in which the slide was held in position on the leaf by a catch and spring. The leaf was graduated from 200 to 1,300 yards in 100 yard increments, and embodied a battle-sight for ranges up to 400 yards. This sight was eventually adopted and introduced on 23rd April, 1943 as the Mark III. Although fulfilling its purpose, it was soon in trouble with the troops; the protruding catch-head was easily damaged and broken, and the slide was not efficiently secured by the influence of the small coil spring. The sight was soon replaced by the Mark IV, a very similar pressed steel pattern but with curved catch, making it less vulnerable to damage, actuated by a stronger spring of the mouse-trap type (see Fig. 17).

The many war-time modifications embodied in the No. 4 Rifle were largely alternative designs of component parts to meet the requirements of various manufacturers. Although the rifles were assembled at the Ordnance factories, many of the components were made elsewhere, often by small firms with no previous experience in the manufacture of weapon parts. To save machine-tools, pressings were used whenever possible, and there was much fabrication by the welding together of small parts. Throughout the war many of the part drawings of the rifle were under almost constant amendment. Components having alternative designs included upper and lower bands, foresight blades, foresight protectors, block bands, locking bolts, trigger-guards and sling swivels and brackets. One of the most unpopular concessions was the omission of the half-bent from the cocking-piece, which rendered the rifle definitely dangerous. Fortunately this was short-lived; wiser counsels soon prevailed and forced the restoration of the half-bent. Under the circumstances

it was not surprising that the standard of the No. 4 probably reached a lower level than ever before in the history of Lee-Enfield rifles. Nevertheless it remained a very accurate weapon and, in the days of danger immediately following Dunkirk, the emphasis was very rightly on making rifles which would fire a cartridge rather than on their appearance. Many of the early war-time rifles had to be examined and rectified at Enfield, and at the Ordnance Depot at

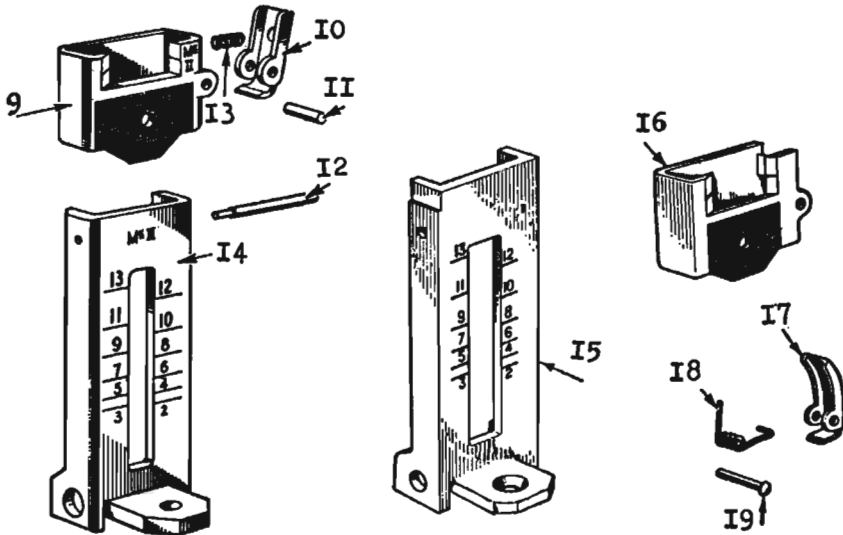

FIG. 17. Backsight Assemblies.

Mark III.

- 9. Mark II Slide.
- 10. Mark I Catch.
- 11. Catch pin.
- 12. Stop pin.
- 13. Mark I Spring.
- 14. Mark II Leaf.

Mark IV.

- 15. Mark III Leaf.
- 16. Mark III Slide.
- 17. Mark II Catch.
- 18. Mark II Spring.
- 19. Pin.

Weedon, by Enfield examiners, before they could be issued to the Army. Weapons which were known to embody components not strictly interchangeable bore the letter "A" after their serial numbers; when replacements were required which could not be satisfied by the normal spare parts, the rifles were handed in to Army Stores for exchange. Magazines on a number of rifles were found difficult to load with ten rounds, and in 1942 an Army Council Instruction was issued informing units that owners of these defective arms must load initially with one charger and, after firing one or more rounds, load the remaining five. New magazines were subjected to a very thorough inspection after manufacture and the letter "B" stamped on the solid rib on the back indicated that they were up to the required standard. In 1942 efforts were made to simplify the No. 4 Rifle, and designs were submitted for investigation

embodying a fabricated body and bolt, a drawn tube barrel which was a shrink fit to the body, and a skeleton stock. The three principal difficulties now facing production were scarcity of suitable labour, shortage of machine tools and a dearth of good timber.

Barrel making was another serious "bottleneck" in rifle manufacture and efforts were made to simplify the process. In May, 1941, trials were carried out with barrels having two grooves instead of the normal five. A number were fitted to No. 1 Mark III* Rifles and were found to be satisfactory and comparable to the normal barrel. Further trials were carried out to establish their accuracy life and whether they developed any tendency to nickelling under Service conditions. Two No. 1 Rifles with two-grooved barrels were tried against two No. 1 Rifles with normal barrels. They were fired for accuracy, submitted to a functioning test in which the rate of fire was ten rounds in 1 minute, and re-shot for accuracy whilst they

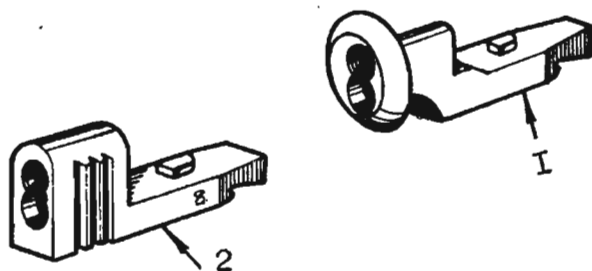

FIG. 18. *Cocking-pieces. A war-time alternative.*

1. Mark I. 2. Mark II.

were still hot. This was continued in cycles of fifty rounds until 500 rounds had been fired through each rifle. There was no appreciable difference between the two forms of rifling in either accuracy or barrel wear, and nothing to suggest that the two-groove barrel would be prone to excessive nickelling or fouling. It was decided to adopt the two-groove barrel as an alternative form of rifling for all .303-in. rifles. Many thousands of these Mark II barrels were made for the No. 4 Rifles and gave excellent service. To further ease production difficulties it was decided to omit the final operations of fine boring and lapping from the barrels of No. 4 Rifles. Tests had shown that there was no excessive nickelling in barrels from which these operations had been omitted. Permission was also given to manufacture barrels for the No. 1 Rifle with four grooves, where such a method was of assistance to the manufacturer. A few of these barrels were made for the No. 4 Rifle. In 1942 a trial was carried out with barrels which had three grooves. After 5,000 rounds had been fired through them, their accuracy was still good.

The project was eventually dropped and the barrel never went into production.

In 1943 a fabricated barrel, which became the Mark III, was temporarily approved for the No. 4 Rifle. It had five grooves, was manufactured from a drawn steel tube, and was fabricated at the rear end. A sleeve embodying the Knox-form was shrunk on to the breech end of the barrel and further secured in position by two transverse pins. The finish of the bore was not as bright as that of a barrel made by the normal methods, and was easily mistaken for a dirty barrel. Special instructions were issued to the British troops who were issued with rifles with drawn tube barrels to ensure that they were not penalized in this connection. Although these barrels had performed creditably in trials before they were approved, they were not a success in the Service and production was soon stopped. There was a tendency for movement to develop between the barrel and the sleeve. For purposes of identification these barrels were marked with the numeral "III", denoting Mark III, and the maker's trade mark, on the flat at the rear of the barrel. Straight barrels have always been a feature of British Service rifles and barrel viewing in the factories has long been considered a highly skilled job. In order to find out whether the standard could be relaxed, a trial was carried out in 1943 at B.S.A. Factory. Straight barrels, assembled to No. 4 Rifles, were shot for accuracy and the points of mean impact noted. The barrels were then bent, the M.P.I.s checked, and they were again shot for accuracy at intervals over a period of about two months. The results showed that the bends had no effect on accuracy and it was considered that, providing the last 6 ins. of a barrel was parallel to the required line of departure of the bullet, the point of mean impact and accuracy would be satisfactory. As a result of these tests, a system of gauging barrels for straightness by 6-in. plug gauges was introduced. This allowed a slight relaxation in barrel straightness and eased the problem of shortage of skilled viewers.

With the object of increasing supplies of the No. 4 Rifle, an all-metal model was submitted by the Production Branch of the Ministry of Supply. It weighed approximately the same as a normal rifle, the four main wooden components having been replaced by three of pressed steel. The metal parts were treated with a form of synthetic rubber which was impervious to acids, alkalis, alcohol, petrol, benzole and oil. It was claimed that elimination of the woodwork would effect:

- (a) Saving in time, machines and skilled labour. Steel pressings could be turned out quicker, and in fewer operations, by unskilled labour.
- (b) Saving in metal fittings required to attach woodwork to rifle,

and the tools, machines, jigs, and time involved in their production.

- (c) Saving in shipping space needed to import the required timber.

The apparent disadvantages of the all-metal arm were considered to be:

- (a) The probability that it would become intolerable to touch in extremes of heat and cold.
- (b) The rubber coating might melt or become soft.
- (c) The rifle would probably be noisy in handling and unsuitable for night patrols, etc.
- (d) Its accuracy was an unknown factor.

The rifle was sent to the Experimental Establishment at Pendine, South Wales, for trial, with the object of testing:

- (a) The possibility of handling it under extremes of heat and cold.
- (b) Accuracy, under similar conditions.
- (c) The general construction of the rifle as regards stocking-up and serviceability.
- (d) Damage that might be caused by firing grenades from a cup-discharger assembled to the weapon.
- (e) Damage through rough handling and drill.
- (f) Rust-proofing and resistance to abrasion of the rubber coating on the metal furniture.

A normal No. 4 Rifle was put through the same trial for purposes of comparison. As a result of the trial it was decided that the all-metal rifle in its existing state was not fit for issue to troops. The Ordnance Board, who had instigated the trial, considered that the disadvantages which had been disclosed outweighed the advantages claimed for the all-metal construction. The disadvantages were mainly "user" rather than "technical" considerations. A further six rifles were submitted for trials, but considerable difficulty was experienced in trying to get them to shoot to the required acceptance limits. The all-metal furniture did not allow the necessary adjustments in stocking-up to be made and, in April, 1943, the project was abandoned.

For many years walnut dried by natural means had been the recognized wood for furnishing the British Service rifle. For several years before the War it had been realized that, owing to the length of time required for the natural drying, or seasoning, of timber, there was likely to be a great shortage of suitable rifle furniture in the event of an emergency. Great improvements had been made in the process of artificial drying and, in 1935, it was decided to carry



THE TELESCOPIC LAYER

This instrument was used for laying an aim when accuracy testing Lee-Enfield Rifles from the Enfield Rest. It is a telescopic sight mounted on a bar; the front end of the bar is grooved to fit over the foresight, and the rear end has adjustment for fitting the "U" of the backsight. Special fittings were required for using this instrument with the No. 4 Rifle because of its different sighting arrangement.

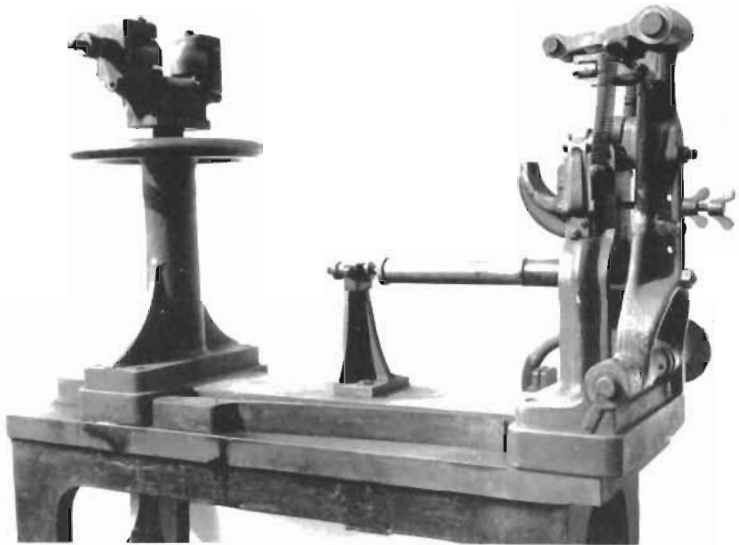
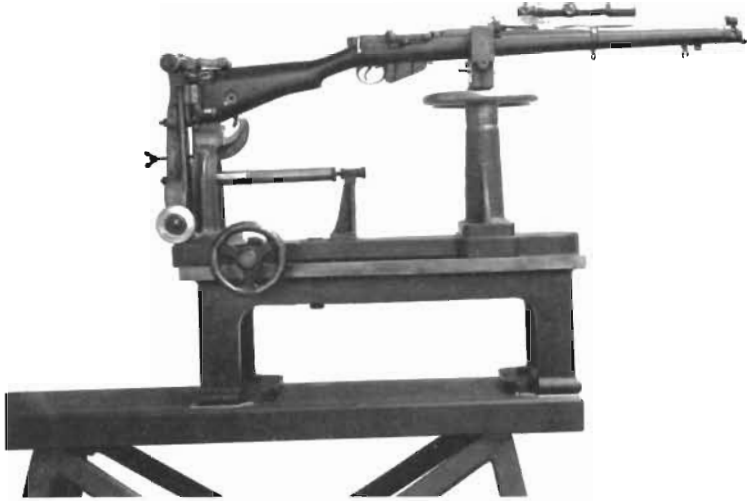

THE ENFIELD REST

Top: A No. 1 (S.M.L.E.) Rifle in position on the Enfield Rest, ready for accuracy shooting with the telescopic layer.

Bottom: The Enfield Rest, which was designed to hold a rifle in approximately the same manner as regards points of support, recoil, etc., as it would be held by a firer. Means are provided for laying the aim correctly by the manipulation of hand wheels. They were installed in all British Ordnance Factories where rifles were manufactured.

out experiments with rifles stocked-up in kiln-dried walnut. When the No. 4 Rifle went into mass production supplies of walnut soon had to be augmented, and kiln-dried beech and birch were approved as suitable for rifle furniture. As British shipping losses mounted, timber imports lessened, and the supplies and quality of the wood diminished. Shrinkage and warping were common faults, and stocking-up became much more difficult to achieve and maintain. With little skilled labour available for correcting and fitting the wooden components, relaxations had to be granted. These permitted a gap, not exceeding .01 in., between the back face of the fore-end and the front face of the butt socket, after firing, providing there was a full bearing of the sear lugs on the wood and no noticeable looseness of the fore-end. The barrel seating at the muzzle end was dispensed with; this was floated out to leave a clearance all round the barrel. The barrel had to be free from any influence by the stock fore-end forward of the reinforce. The relaxations were never permitted for Sniper Rifles. Other countries were also suffering from a dearth of good timber for rifle manufacture. In 1943 a factory in West Germany was reported to be making stocks for rifles and carbines from wood manufactured by a special process. Layers of wood, believed to be birch, 1 mm. in thickness, were superimposed on each other with horsehair chair fibres and a substance called "Tegofilm" between them. They were put under pressure of 23 atmospheres in a hot press and, from each resultant block of wood, stocks for eight weapons were obtained. The stocks were finished off in milling machines and impregnated with oil. They were heavier than walnut, and the required moisture content was obtained by a specially regulated chamber. In March, 1943, a trial was carried out by the Small Arms Inspection Department at Enfield with a captured 7.92-mm. German rifle. The body had been made in Poland and the stock was made of this manufactured plywood. It was subjected to exposure and storage trials lasting several weeks and afterwards shot for accuracy. This had not been adversely affected by the trials and little variation was found in the points of mean impact. The wood had not warped to any serious extent and had shown no signs of disintegration, and was considered quite satisfactory in all respects. Several trials were carried out at Enfield with plastic furniture, but no satisfactory substitute was found to replace wood. Plastic material was usually too heavy and not sufficiently resilient for this purpose.

Another fabricated spike bayonet was introduced for the No. 4 Rifle on 12th February, 1943. This was the Mark III and it differed little in appearance from the Mark II and Mark II*. Fabrication was mainly in the construction of the socket. In July, 1943, the Mark II scabbard was approved. It differed from the Mark I in that the body was not tapered but was made from straight steel

tube and had a cup-shaped tip. This pattern was soon followed by the Mark III, which was similar in shape to the Mark I but the body was made of a plastic material instead of steel. In September, 1944, a Mark VI bayonet was introduced for the No. 1 Rifle. This was similar to the bayonet fitted to the No. 5 Rifle, and had a flat type blade with double cutting edge at the front end.

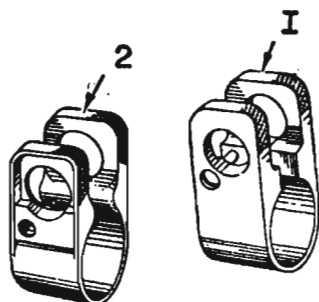

FIG. 19. *Foresight-protectors.*
1. Mark I. 2. Mark II.



FIG. 20. *Foresight Block Bands.*
Block Mark I. Block Mark II.



Mark I.



FIG. 21. *Foresight Blades.*
Mark I*.



Mark II.



Mark III.

A fabricated foresight protector, the Mark II, was introduced on 22nd April, 1943. This was made from pressed steel with two inserts welded or brazed in position to hold the securing screw (Fig. 19). A new pattern blade foresight was also approved. This was called the Mark I* and it differed from the Mark I by having a slot cut in the base of the dovetail (Fig. 21). It was used with the solid type of foresight block, the cut in the base being designed to allow the blade to be forced into position in the dovetail slot in

the block, and afterwards expand sufficiently to remain securely in position. In 1944 the Marks II and III foresight blades were approved for manufacture. They were similar respectively to Marks I and I* but differed in having their platforms increased in length at the rear end to allow the angular face to be machined parallel to the rear angular face of the blade. This modification tended to reduce light reflection at this point during alignment of sights for shooting (Fig. 21).

CHAPTER XV

WEAPONS FOR THE JUNGLE AND THE SNIPER

IN the early summer of 1943 reports of recent fighting in the jungle showed that mobility was a most essential characteristic of infantry engaged in this type of warfare. To ensure this mobility it was necessary to reduce the weight the soldier had to carry as much as possible. Investigations were accordingly commenced with a view to reducing the weight of the No. 4 Rifle, the jungle requirement for the British Army being a light handy weapon with good accuracy up to 400 yards. By the end of the year the Government designers at Enfield submitted a prototype weapon for trials by the Small Arms School, which had now moved from Hythe to Bisley Camp. The initial trials revealed the muzzle flash to be excessive but the fitting of a flash eliminator removed this objection. Accuracy of the lightened weapon compared favourably with that of the No. 4 Rifle up to a distance of 500 yards and, after the embodiment of a few minor modifications, further trials took place. In July, 1944, a trial took place at Pendine to assess accuracy and endurance, determine muzzle flash, and test for rough usage. Three lightened rifles, now known as the No. 5 Rifle, were used, together with one new and one part-worn No. 4 Rifle for purposes of comparison. No muzzle flash was observed in daylight from any of the weapons, and at night the flashes which were seen were only small and faint. The conclusions reached were:

- (a) The accuracy life of the lightened rifle was probably in excess of 6,000 rounds.
- (b) The muzzle flash was no worse than that of the No. 4 Rifle.
- (c) Rough usage had a rather greater effect on accuracy than it did on the No. 4 Rifle.

It was later ascertained that the "jump" measurements of fifty rifles tested, with and without the bayonet, were somewhat inconsistent.

Now that most of the teething troubles of the new rifle had been discovered and overcome, it was decided to try and establish accuracy barrel life. A trial was carried out at Pendine in which the

normal Service Mark VII ammunition and the nitro-cellulose loaded Mark VIIz was used. With the lightened rifles, the size of the accuracy diagram increased at an early stage and, with the bayonet fixed, they were about 20 per cent larger than without the bayonet. The effect of the bayonet on point of mean impact varied with individual rifles from plus 2 to minus 9 minutes of angle, the mean being minus 4 minutes. The woodwork of the No. 5 Rifles was considerably charred as a result of their firings and it was thought possible that the early deterioration in accuracy was due to this cause. The conclusion arrived at was that Mark VIIz ammunition could be used up to 6,000 rounds and the normal Service cartridge to over 11,000 rounds. There were, however, so many discrepancies in the results which were obtained that the trial was not considered conclusive as regards barrel life with Mark VIIz or with mixed lots of Mark VIIz and Mark VII.

Details of the No. 5 RIFLE, MARK I, were as follows:

Length of rifle	3 ft. 3½ in.
" " barrel	1 ft. 6¾ in.
" " rifle with bayonet	3 ft. 11½ in.
Weight of rifle	7 lb. 2½ oz.
" " " with bayonet	7 lb. 13 oz.
" " magazine (full)	14¾ oz.
" " " (empty)	5¾ oz.
Capacity of magazine	10 rounds
Sight radius	1 ft. 11·14 in.
Maximum sight range	800 yds.

(Fig. 22)

The rifle was chambered for the normal .303-in. rimmed cartridge and the rifling details were the same as the No. 4 Rifle. It was fundamentally the No. 4 Rifle reduced in weight, fitted with a barrel reduced in length, with a combined flash eliminator, bayonet standard, and foresight protector fitted to the muzzle. A special rubber pad was fitted to the butt to overcome the extra recoil resulting from the reduced weight of the rifle. The stock fore-end was shortened, exposing a greater length of barrel, and components were lightened wherever possible. The backsight was similar to the No. 4 Mark I sight but was graduated from 200 to 800 yards instead of to 1,300 yards (Fig. 23 (a) and (b)). A new type of blade bayonet, the No. 5 Mark I, was used. It had wooden hand-grips and was attached to the rifle in the same manner as the bayonet on the No. 1 Rifle, the ring of the cross-piece fitting over the flash eliminator. The blade had a groove down each face and a strong rigid back (Fig. 25).

The method of stocking-up was as follows:

(a) The fore end fitted tightly at the rear end between the sear

lugs and the butt socket of the body. After the rifle had been fired, a gap not exceeding .01 in. was permissible between the rear face of the fore-end and the butt socket, provided that:

- (i) There was a full bearing of the sear lugs on the fore-end.
- (ii) With the front trigger-guard screw unscrewed there was no noticeable movement of the fore-end.

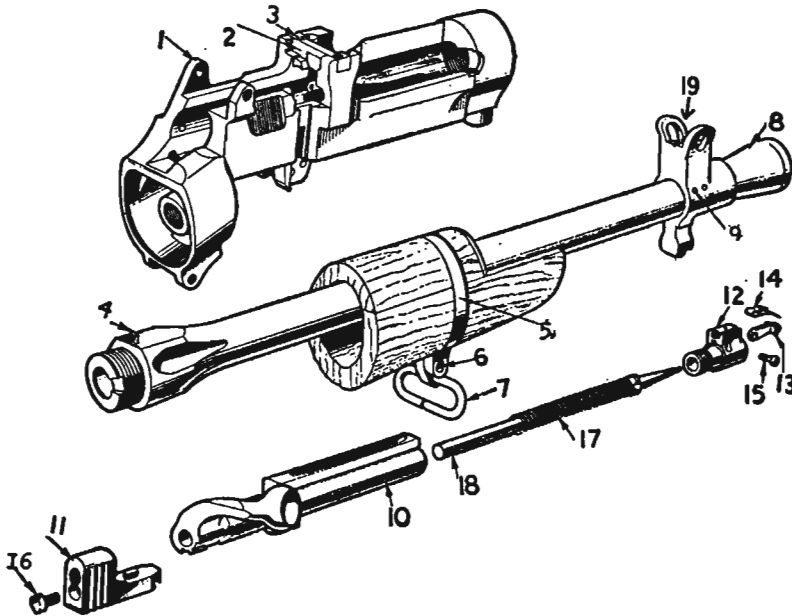

FIG. 22. No. 5 Rifle, Mark I. Body, Barrel, and Breech Bolt.

1. Body.	8. Flash	14. Spring.
2. Bridge.	Eliminator.	15. Screw.
3. Screw.	9. Pin.	16. Striker screw.
4. Barrel.	10. Breech bolt.	17. Mainspring.
5. Band.	11. Cocking-piece.	18. Striker.
6. Screw.	12. Bolt-head.	19. Foresight
7. Swivel.	13. Extractor.	protector.

- (b) A good bearing was effected on the body surfaces, around the front trigger-guard screw hole, and along the ledges on each side of the magazine opening, extending rearwards for not less than $2\frac{1}{2}$ in. The fore-end was clear on either side of the body barrel socket.
- (c) A good bearing was necessary at the reinforce, extending its full length and half its width. It was important that this bearing was central in the reinforce seating, and the sides of the fore-end at this point clear of the barrel.

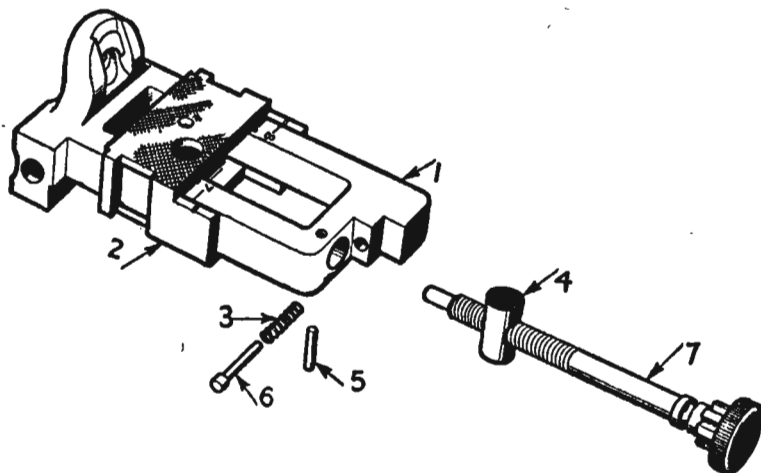

FIG. 23(a). No. 5 Rifle, Mark I, Backsight.

- | | |
|--------------------|---------------------|
| 1. Leaf, Mark I. | 5. Retaining pin. |
| 2. Slide, Mark I. | 6. Plunger. |
| 3. Plunger spring. | 7. Adjusting screw. |
| 4. Adjusting nut. | |

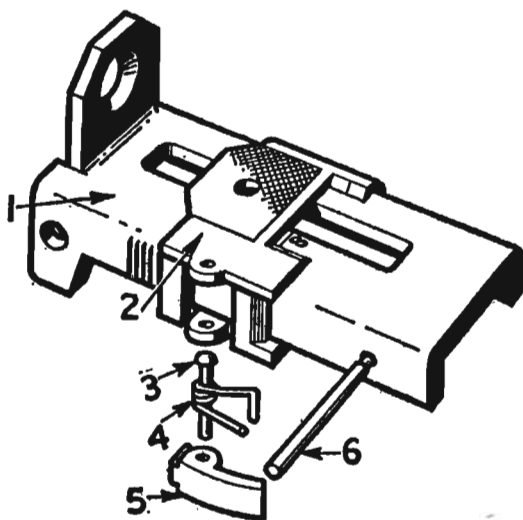

FIG. 23(b). No. 5 Rifle, Mark II, Backsight.

- | | |
|---------------------|---------------------|
| 1. Leaf, Mark II. | 4. Catch spring. |
| 2. Slide, Mark III. | 5. Catch, Mark III. |
| 3. Catch pin. | 6. Stop pin. |

- (d) There was a clearance of not less than .04 in. at the muzzle end, and the barrel was free from any influence by the fore-end forward of the reinforce. The hand-guard was also clear of the barrel. (Fig. 24.)

The new British rifle for jungle warfare was officially introduced on 12th September, 1944, by which time over 20,000 had been manufactured and, by the end of the year, over 50,000 had been accepted for service.

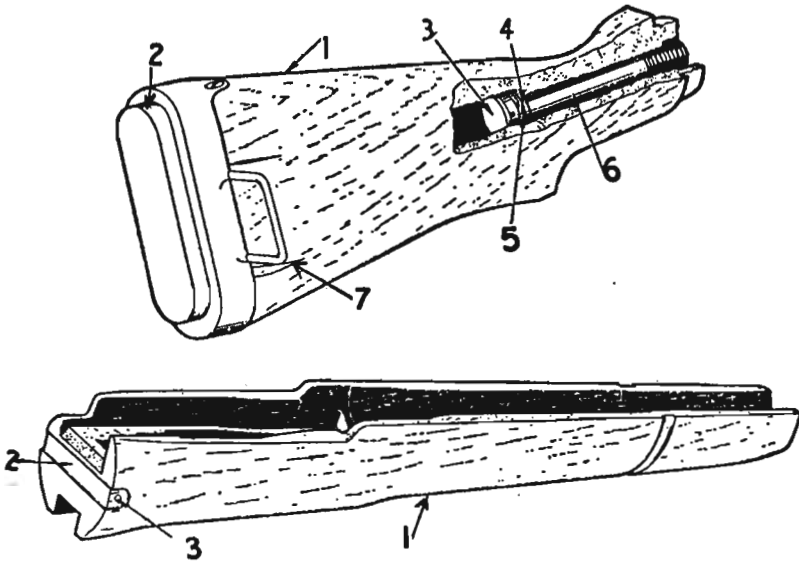

FIG. 24. *Butt and Fore-end.*

- | | | |
|----------------|-------------------|---------------|
| 1. Butt. | 5. Spring washer. | FORE-END. |
| 2. Butt plate. | 6. Stock bolt. | 1. Fore-end. |
| 3. Wad. | 7. Sling swivel. | 2. Tie plate. |
| 4. Washer. | | 3. Rivet. |

The No. 5 Rifle performed admirably in the role for which it was designed and, despite its rather unpleasant recoil, was popular with the troops as a jungle fighting weapon. After the war it had many supporters, and at one time it seemed possible that it would replace the No. 4 Rifle as the British Service arm. It had, however, one big fault: it was not easy to keep correctly sighted, and suffered from what was known as a "wandering zero". This was a serious defect and many attempts were made to eradicate it. Trials were carried out with different forms of stocking-up and a Mark II pattern was eventually developed, with which further trials were carried out in 1945 and 1946. In the new pattern the stock fore-end and hand-guard were extended to within about $\frac{1}{2}$ in. of the rear of the flash

eliminator, and the rear end of the stock fore-end was strengthened by a stout screw and nut. The band was positioned about three inches farther forward to secure the lengthened fore-end and hand-guard and sling swivels were fitted on the left side of fore-end and butt. The Mark II never went into production, and it was eventually decided that the cause of the "wandering zero" was inherent in the design of the weapon and not the result of movement of unseasoned woodwork as had been suspected. The decision not to

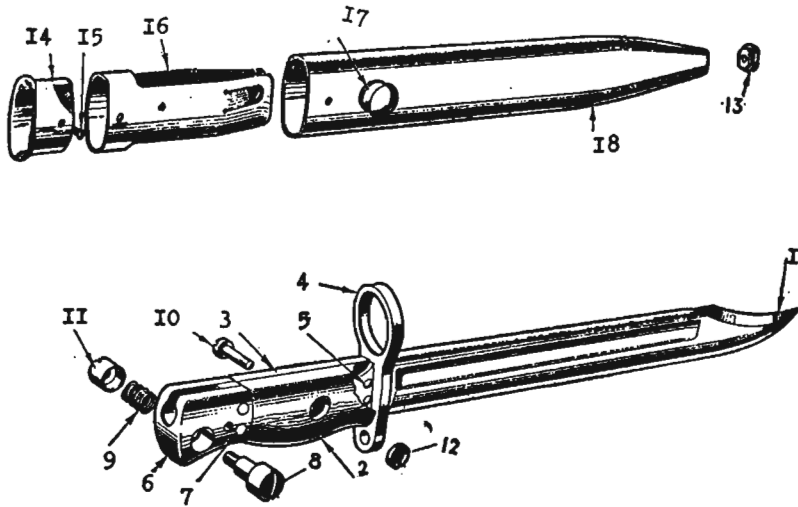

FIG. 25. No. 5 Bayonet, Mark I and No. 5 Bayonet Scabbard, Mark I.

- | | |
|----------------------|--------------------------|
| 1. Blade. | 10. Grip screw. |
| 2. Handgrip. | 11. Bolt nut. |
| 3. Handgrip. | 12. Grip nut. |
| 4. Crosspiece | 13. Scabbard tip. |
| 5. Crosspiece rivet. | 14. Scabbard mouthpiece. |
| 6. Pommel. | 15. Mouthpiece screw. |
| 7. Securing rivet. | 16. Spring. |
| 8. Bolt. | 17. Button. |
| 9. Bolt spring. | 18. Body tube. |

retain the No. 5 Rifle in the British Service was made in July, 1947, and it was declared obsolescent.

Little advance had been made in the provision of sniping equipment for the British Army between the two wars and in 1940 the Pattern 1914 Rifle, fitted with either the Aldis or the Pattern 1918 Telescope sight, was still the sniping arm. Whilst the rifles were extremely accurate, the telescopes, though excellent instruments for their purpose, were somewhat outdated. The Pattern 1918 had no external adjustment for deflection and zeroing it to a rifle was a somewhat intricate operation. Correcting an error in either direction was achieved by turning the prism cell in the direction of the error, after three tiny fixing screws had been slackened. The prism,

being wedge-shaped, bent the ray of light. Correcting a lateral error also affected elevation, which then had to be checked. Elevation was obtained by means of a range drum on which was a scale graduated in hundreds of yards from 100 to 1,000 yards. The Aldis offset telescope had a range drum with a range scale graduated in hundreds of yards from 100 to 600 yards. Lateral adjustments were made on the telescope bracket but the method was rather crude and it was not easy to effect fine adjustments. Nevertheless they served their purpose well until superseded by a more up-to-date equipment.

On 20th March, 1940, a telescope sight, known as the No. 32 Mark I, was recommended for adoption for use with the No. 4 Rifle. Originally designed for the Bren L.M.G., it was a rather heavy instrument compared with modern sporting telescopes and weighed 2 lb. 3 oz. It was sighted from 0 to 1,000 yards and could be adjusted in intervals of 50 yards by turning a range drum positioned on top of the sight, in which was a "clicker" device. Lateral adjustments were effected by means of a deflection drum at the side of the sight. This also embodied a "clicker" device, each "click" representing two minutes of angle. If the error on the target was to the right, it was corrected by turning the range drum in a clockwise direction, and vice versa. The magnification was three times, and the field of view was 9 degrees.

On 12th February, 1942, the No. 4 RIFLE, MARK I (T) was introduced as the new sniping equipment for the British Service, the rifles being fitted with the new No. 32 Mark I telescope sight. The rifles were all specially selected, and had to pass a slightly higher standard of accuracy test than for normal service. The earlier rifles for conversion were taken from Army store and carefully re-stocked at the Royal Small Arms Factory, Enfield, where they were fitted with telescopes and tested for accuracy. The conversion consisted of fixing two steel pads to the left side of the body and fitting a telescope bracket, or holder, to the pads. It was a job which had to be very carefully done to ensure correct alignment of the telescope with the rifle barrel, and complete stability of the telescope, when the bracket was screwed on to the pads. The rifle, with telescope fitted, was then submitted to its accuracy test, which was to place seven out of seven shots into a 5-in. circle at a range of 200 yards. When possible, rifles were also tested at 400 yards, when six out of seven shots had to go into a 10-in. circle. Every rifle was also correctly zeroed with both telescope and Mark I backsight, with which they were fitted for use in case of emergency. (See Fig. 26.)

From 22nd September, 1942, the work of conversion was carried out by Messrs. Holland & Holland, the well-known London gunsmiths. This firm dealt with nearly 25,000 equipments and a high standard of fitting was maintained; the rifles now all coming from the B.S.A. Factory at Shirley, Birmingham. To facilitate identifica-

tion, and avoid incorrect assembly, each rifle was marked with the number of its telescope; this being stamped on the flat portion of the butt behind the cocking-piece. Eventually wooden cheek-pieces were fitted to the butts as further aids to the sniper. An improved telescope sight, the Mark II, was introduced on 23rd April, 1943. It differed from the Mark I principally in the graduations of the

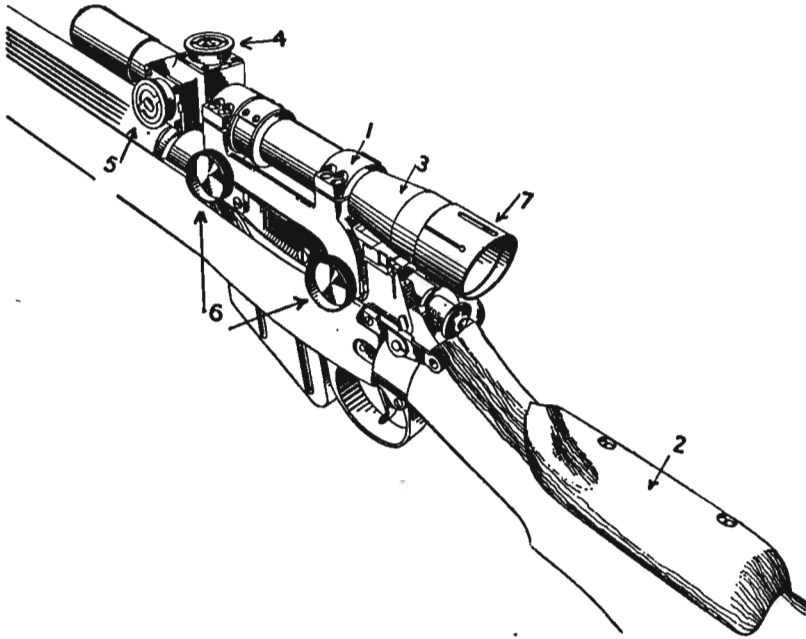

FIG. 26. *The British Sniper's Equipment.*

- | | |
|----------------------------|----------------------------|
| 1. Bracket, or Holder. | 4. Range (Elevation) Drum. |
| 2. Cheek Rest. | 5. Deflection Drum. |
| 3. No. 32 Telescope Sight. | 6. Clamping screws. |
| | 7. Eye Shield. |

range and deflection drum heads, and in the design of the clicker plate. The Mark II clicker plate was graduated in intervals of one minute of angle, instead of two minutes of angle as in the Mark I. The magnification was 3 and the field of view 8 degs. 20 mins. The telescope was further improved by the embodiment of a slipping micrometer drum adjustment for easier zeroing and, on 7th October, 1944, was introduced into the British Service as the Mark III. It was similar to its predecessors, and differed only in one other small detail from the Mark II, the field of view being 8 degs. 30 mins. It was eventually made waterproof and the lenses were "bloomed" to give them greater light-gathering power. Included in each sniper

equipment, which was issued in a wooden chest, was an excellent telescope for purposes of observation.

The first issue of the new British Sniping Equipment was made two months before it was officially introduced when, in December, 1941, No. 3 Commando were issued with twelve. Within the next two months over 150 equipments had been despatched to units, mostly in Far Eastern theatres of war. The equipment was popular with the British snipers and was undoubtedly one of the most efficient in use in any army. At Enfield, comparative trials were carried out from time to time with captured enemy sniper rifles, and in every instance the British rifle proved the more accurate. In September, 1945, two M.I.C. American Sniping Equipments were submitted to tests and, although recording a good standard of accuracy throughout the trials, they were inferior to the No. 4 (T). In maintenance of M.P.I., ease of aim, and manipulation of telescope sight, the British equipment also showed to advantage.

A trial was carried out by the Small Arms Inspection Department at Enfield in 1945 with the object of determining the effect of the telescope on the angle of "jump" of the No. 4 Rifle. Twenty-six run-of-work equipments which had passed their normal acceptance tests were fired for group at 200 yards with, and without, their telescopes assembled. Without the telescopes the angle of "jump" varied from plus 4.5 mins. to plus 12.5 mins., the mean for the twenty-six rifles being plus 8.95 mins. With telescopes assembled it varied from minus 2 mins. to plus 4.75 mins., the mean being plus 2.27 mins. The effect of the telescope thus showed a mean decrease in "jump" of just over $6\frac{1}{2}$ mins. Whether it improved accuracy was not established as no further trials took place but, throughout the war, the Sniper rifle invariably passed its accuracy test well within the required acceptance limits.

CHAPTER XVI

MANUFACTURE AND FACTORY HISTORY

THE method of manufacture of the Enfield rifle changed little after the introduction of the first Short Lee-Enfield, though advancement in the technique of welding and fabrication did allow an easement in the machining of certain components during World War II. There were approximately 130 parts in a Short Lee-Enfield rifle, and the manufacture of each part was governed by drawings and specifications. The drawings showed the exact shape and dimensions of each part, and the dimensional limits within which they had to be maintained. Details of required hardness, surface finish, and rustproofing treatment were also given, and further drawings showed methods of assembling. The specifications gave particulars of the materials from which each part had to be made; the stages of manufacture at which each part was inspected; details of markings, etc.; and the conditions governing the acceptance of the finished weapon. In order to ensure the necessary qualities of accuracy of shooting, safety, wearing qualities and interchangeability of the various parts, an independent inspection was carried out by the Government Small Arms Inspection Department, under the direction of the Chief Inspector of Small Arms.

All the working parts of the rifle were made of steel, and an approved wood was used for the furniture. The properties of steel, the most important of which was (and still is) that of hardening by heat treatment, vary with the proportions of alloying elements. Carbon, in varying proportions, is necessarily present in every form of steel and is the controlling factor, but many other elements such as nickel, chromium, tungsten, manganese, molybdenum, zirconium, vanadium and silicon play an important part. The grade of steel for each component was carefully selected in accordance with the work it would have to do, the cost of manufacture also receiving due consideration. The steel was ordered in what was considered to be the most convenient form for the subsequent operations, in order to minimize the work and conserve material. For example, bodies were forged from rectangular bars, magazine cases stamped out of

sheet steel and subsequently brazed or welded, and barrels were made from round bars either by forging or "upsetting" (a term applied to a form of squashing a portion of a work-piece). The principal manufacturing processes, once the material had been delivered to the factory, was forging and machining. Forging was used to bring to a rough approximate shape of the finished component, thus saving wasteful machining, and improving the mechanical properties of the material. Drop forging was the method which was generally used. In this the bar, heated to a bright red, was brought to shape between two dies which had been specially made for each component; one being held on the anvil or base, and the other secured to the "tup" or moving part of the hammer. It was sometimes necessary to use several sets of dies to bring the forging to its finished shape. The barrel bars were drawn down to the rough shape of the barrel, or "upset" in a forging machine to produce the "Knox-form", i.e. the enlarged rear part of a barrel in which the chamber is formed. "Upsetting" is a more modern method of manufacture.

The machining of components was considered to be representative of the best class of small repetition work and was carried out on simple lathes, capstan lathes, automatic lathes, milling, drilling, profiling, slotting and boring machines, and in some cases special purpose tools were used. The majority of the components had to undergo many operations before they were completed, the body having about 150 before it was finished. Considerable ingenuity on the part of the tool makers had been shown in perfecting machines to perform the operations automatically or semi-automatically, and produce the greatest number of components with the minimum of labour. As far as practicable, machine tools of standard design were used, but sometimes special machines were designed, made and used by the factories making the rifles. Once set up to perform a certain operation, a machine cannot keep on repeating it indefinitely. Due to small errors in the machine, and the inevitable wear of fixings and cutting tools, it is necessary to fix manufacturing limits within which the serviceability of a component is not appreciably affected. These limits, which were sometimes within two-thousandths of an inch, varied according to the importance of the component and the stage of manufacture which had been reached.

The machined parts were finished in various ways, according to their use and the position they occupied in the completed weapon. Most of the metal work which showed on the outside of the rifle was either browned or oil-blackened. (These processes were discarded during World War II, and replaced by phosphating and spray painting.) Those parts which were subjected to wear were hardened and tempered, to the degree laid down in the specification. Hardening was effected by heating the part to an appropriate temperature and quenching it by suddenly immersing it in oil or some other

liquid. This left the metal brittle and a further tempering operation was necessary. This consisted of again heating the metal, this time to a lower temperature than before, and allowing it to cool. The amount of "temper" was governed by the heat to which the article was raised. In case-hardening a very hard surface was obtained by heating components in a charcoal (not now used) or other carburizing medium and quenching them in oil or water, or re-treating in order to obtain a hard surface and a ductile core. (Only steels of very low carbon content can be treated in this manner.) Case-hardening ensured great resistance to wear combined with resistance to fracture under stress.

The boring and rifling of barrels was one of the most important operations and great care was bestowed on it. It was necessary to achieve both straightness and accuracy of size of the bore. After forging, the barrel was rough-turned to its exterior shape and then drilled. The drilling was "straight through" from end to end and carried out in one operation. In drilling and boring the bits and reamers did not rotate, the barrel revolving at the required speed. The tools were on holders fixed to the moving slide of the machine and were gradually forced through the forging. A lubricant was pumped through the bits to keep them cool and wash out the cuttings from the bore. Besides being straight, the bore was kept concentric with the exterior of the barrel. A high standard of finish was maintained.

The test for straightness was by light and shade effects within the bore. Deformation of the conical shadow, seen in the bore when viewed towards the light, indicated the position and magnitude of a bend, which was removed by blows on the exterior of the barrel with a copper or brass hammer. This method demanded a considerable amount of skill, usually only acquired by long practice, on the part of the viewer. (During World War II a great deal of barrel viewing had to be done by viewers with comparatively little experience and eventually a new system of testing for straightness was introduced, by the use of 6-in. steel plug gauges: see Chapter XIV.) The rifling grooves were cut one at a time, a very light cut of about one three-thousandths of an inch being removed from each of the five grooves in succession. It required several cuts, in series of five, to complete the rifling. As the cutting tool moved through the barrel the necessary amount of spiral was achieved. (A quicker method of barrel manufacture was permitted for a short period during World War II. This was known as the drawn tube method, the rifling being formed over a mandrel, the Knox-form being shrunk on and pinned to the rifled tube: see Chapter XIV.) The rifled barrel was then screwed at the breech end (afterwards done by thread rolling) for attachment to the body. In this operation care was taken to ensure that the thread was in proper relation to the Knox-form,

this being the base from which the body, barrel and sights were finally aligned. The chamber was then bored, and the sights fitted. The barrel and action were assembled and proof was carried out by the Small Arms Inspection Department. One proof round giving a pressure considerably in excess of the Service cartridge was fired under conditions ensuring safety to the firer in the event of failure of the barrel to withstand the test. (As will be seen later, two proof rounds were fired with the No. 4 Rifle.) After proof the chamber was brought to finished dimensions; and the barrel, body and bolt-head examined and marked with the proof mark. (With the No. 4 Rifle, chambering was completed in one operation before breeching-up.) The trigger mechanism, magazine, etc., were now fitted to the action and the rifle was stocked-up by assembling the woodwork.

Prior to World War II the woodwork, or furniture as it was called, was of walnut, but shortage of seasoned walnut compelled the use of kiln-dried walnut, beech and birch. The wood was cut to specified sizes and selected for straightness of grain. The pieces were roughly machined to the contour of the finished component on spindle moulding machines or copy turning lathes. Copy turning of the butt was done in a multi-station machine, turning eight butts per cycle. The final machining was done on special woodworking and drilling machines. The wood was finally smoothed by being held against revolving "bobs" impregnated with powdered glass, or against an abrasive band on a wood sanding machine. The finished woodwork was soaked in warm linseed oil for half an hour. All work was kept to close limits of accuracy so that assembly could be carried out with a minimum of hand fitting. (In the production of the No. 4 Rifle the furniture was assembled without hand fitting.) All rifles were tested for accuracy by the Small Arms Inspection Department at 100 feet, and 10 per cent were also fired at 600 yards. All rifles were fired from a special mechanical rest, known as an Enfield Rest, and a special telescope layer was used for laying the aim. The Enfield Rest was designed to simulate the conditions under which a rifle would be held when fired from the shoulder, and was provided with hand wheel adjustments for laying an aim. Trial shots were first fired and, if necessary, the foresight was adjusted laterally, or replaced by one of a different height, until the shots on the target were within the required limits. Five rounds were then fired, and four of the five shots had to be contained in a rectangle 1 in. broad by $1\frac{1}{2}$ in. high. Rifles which failed this test were rejected. At 600 yards ten shots were fired, nine of which had to fall within a 2-ft. circle.

For the No. 4 Rifle, the accuracy test was the same at 100 feet. Ten per cent of all rifles were then fired at 200 yards when six out of seven shots had to fall inside a rectangle 6 inches by 6 inches, the point of mean impact having to be within 3 inches of the point of aim in any direction. Ten per cent of rifles fired at 200 yards were

THE FULTON FAMILY

A wonderful family shooting record was commenced in 1888 when Mr. G. E. Fulton won the Queen's Prize at Wimbledon. The illustration shows him in the winner's chair on that occasion, held aloft by comrades of his regiment, the 13th Middlesex. The illustration below shows his son and grandson who were to follow his example.



On the right is Major Robin Fulton, who won the Queen's Prize at Bisley in 1958, holding his grandfather's Martini-Henry rifle in his right hand, and his own S.M.L.E. which he used in the final stages, in his left hand. On the left is his father, Mr. A. G. Fulton, D.C.M., who has won the Premier award for rifle shooting on three occasions, 1912, 1926 and 1931. He is holding the Long Lee-Enfield Rifle with which he was successful in 1912.



TRIGGER TESTER FOR LEE-ENFIELD RIFLES

This Trigger Tester was designed and made at D.I.Arm. Testing Section, R.S.A.F. Enfield Lock, for the National Rifle Association for use at the Bisley Imperial Meetings. It holds the rifle at the correct angle while the weight is applied to the trigger. It was designed for use in cases of dispute.

again fired at 600 yards when six out of seven shots had to be in a rectangle 18 inches by 18 inches, the permissible deviation of point of mean impact being 9 inches up or down, or left or right. Two per cent of rifles were also fired from the shoulder, ten rounds being fed into the magazine by charger and fired rapid to test "feeding up" and ejection. After these tests the barrel was inspected to ensure that there was no expansion in bore or chamber and that it shaded correctly from end to end. The firing test to which the No. 5 Rifle was subjected was the same as that for the No. 4 Rifle at 100 feet. It was not tested at 200 yards, but 10 per cent were fired at 600 yards when the acceptance standard was ten out of ten shots contained in a rectangle 36 in. by 36 in. Two per cent of No. 5 Rifles were also submitted to the same functioning test as the No. 4 Rifle. Throughout the war much of the accuracy testing was done by women shooters who quickly became proficient at the job. To speed up the procedure, the telescope layer was dispensed with, and aim was taken in the normal way through the backsight. The .1-in. aperture in the backsight was too large for easily laying a correct aim at 100 feet, and a small spring-steel adapter was used. This contained an aperture of about .05 in., and could be quickly fitted and removed from the backsight leaf. Another war-time innovation for weapon testing was a "universal" target; so-called because it was used for the accuracy testing of rifle, light machine-gun, pistol revolver, and machine-carbine. It had a black rectangular aiming mark and embodied the passing limit rectangles for all four types of weapons. Much time and care was bestowed to the zeroing of rifles but, unfortunately, owing to the wartime low standard of the furniture and lack of hand fitting, the ultimate results were disappointing. Rifles correctly zeroed when they left the factories had often completely lost their "zeros" by the time they reached the troops. Before the accuracy acceptance test could be carried out, every rifle was subjected to a "proof" test. Each barrel, with action assembled, had to withstand two proof rounds, the proof charge being designed to give a pressure of 26 tons per square inch, which was approximately 25 per cent in excess of that of a normal Service cartridge. The first was fired dry for proof of the barrel, and the case of the second round was lightly oiled to prove the action, especially the bolt-head. If satisfactory after examination the barrel, body, bolt and bolt-head were marked with the Government proof mark. Components made for "spares" were proofed accordingly.

With three factories in the U.K. manufacturing No. 4 Rifles, separate blocks of serial numbers were allotted, as required, to each factory by the Small Arms Inspection Department, so that no two or more rifles could bear the same serial number. In addition to the number, the identification marks of each factory were stamped or engraved on each rifle it produced. No. 4 Rifles were marked on the

left side of the body and socket. The identification marks of R.O.F. Fazakerley were "FY" or "ROF(F)"; those of R.O.F. Maltby "M" or "RM" or "ROF(M)"; and those of B.S.A. Shirley were "B", "85 B", or "M 47".

No. 1 Mark III and Mark III* rifles manufactured at Enfield usually bore the word "Enfield", surmounted with the royal crown, and "G R" just beneath the crown. The year of manufacture, the letters SHT. (for Short) L.E. (for Lee-Enfield), and III or III* (according to the Mark) were stamped on the right side of the body, or socket. No. 1 Rifles made by the Birmingham Small Arms Company, or the London Small Arms Company, bore the letters "B.S.A.", or "L.S.A.", instead of "Enfield". No. 1 Rifles made in India were stamped "Ishapore" and those made in Australia "Lithgow". Viewers' marks consisted of a number and letter surmounted by a crown.

Although Lee-Enfield rifles have been made in many parts of the world, the recognized home is the Royal Small Arms Factory at Enfield Lock, Middlesex. There is little doubt that the present site on the River Lea was selected on account of available water power, the river having been partially canalized, and so controlled, by Smeaton, the famous engineer. The importance of water power and transport was fully realized when the factory was established in 1804.

Prior to this date, the British Government depended largely on private trade for its supply of small arms, but the wars of the early nineteenth century necessitated purchases from abroad. In 1802 it was publicly acknowledged that the art of making military firearms had become almost extinct in England, and a factory was established in the Tower of London for the manufacture of musket locks and the assembly of components purchased from private firms. Accommodation at the Tower proving insufficient, the manufacture of locks was transferred to a small arms factory at Lewisham, where musket barrels were also being made. In 1816, owing to water power and transport difficulties, the Lewisham factory was closed down and, with the ending of the Napoleonic Wars, barrel manufacture and work on small arms generally was concentrated on Enfield. Five years later the factory became known as the Royal Armoury Mills, and by 1830 the workshops and enclosure covered some seven acres of ground. In 1841 the small arms department at the Tower of London was completely destroyed by fire, together with the stock of flint-lock arms which it contained. For some years the Enfield factory turned out about 7,000 small arms and 1,500 swords every year and, by 1853, the annual output had risen to 50,000 muskets and 5,000 swords. Many of these were made for private firms and for sales abroad, being additional to Government requirements. The Enfield factory had certainly progressed in the fifty years following its first job, which was assembling the Brown Bess musket.

In 1854 a House of Commons committee was set up to consider the cheapest, most expeditious, and most efficient mode of providing small arms for Her Majesty's Service. The Government was considered to be entirely in the hands of contractors, and serious trouble was caused during the American War owing to shortage of small arms and the exorbitant demands of contractors and workmen. Even at Enfield the system was bad, and some of the work in the factory was done by contract. Many of the tools which were used were owned by the workmen, and these men often hired their tools to others. At this period, military weapons made in England were considered to be much inferior to those made in America.

By 1860 the position at Enfield had improved in every respect. No less than 250 skilled and 1,000 unskilled or semi-skilled men were employed. A year later this had risen to an overall figure of 1,700 men, and nearly 2,000 rifles were being manufactured every week. In 1867, the factory was busily employed converting muzzle-loading Enfield rifles to the newly adopted breech-loading Snider. These were the first rifles to be fitted with steel barrels at Enfield, previously wrought-iron had been used for this purpose. On the approval of the Martini-Henry rifle for the British Army in 1871, preparations were immediately made for the manufacture of this weapon, and the first issue to the troops was made in 1874.

In 1878, when British interest in the machine-gun as a weapon of war was growing, and was largely centred in improved patterns of the Gatling gun submitted by Sir W. G. Armstrong and Co., the factory was concerned in the examination of several of these arms. At that time the machine-gun was being considered largely as a weapon for the Navy. In 1885, when the Gardner gun was recommended by the Ordnance Committee for general field service, the factory was authorized to proceed with the manufacture of two 1-barrel Gardner guns and tripods. The guns were of .45-in. calibre and the weight of gun and tripod had to be under 160 lb.

The year 1888 saw an important change in procedure, the inspection of small arms being divorced from manufacture. A separate department was established in the factory, and became the Small Arms Inspection Department. It was supervised by military officers under a Chief Inspector of Small Arms, and came under the control of the Master-General of Ordnance. Its duties soon became more widespread, and included inspection of small arms and components wherever they were manufactured, inspection of arms in the hands of troops (see Chapter VI, "Travelling View"), technical weapon trials, and the sealing of patterns to guide manufacture. In 1939 it came under the control of the newly-formed Ministry of Supply and eventually became a division of the Inspectorate of Armaments. It still has a Testing Section and Pattern Room, in which is an

invaluable comprehensive collection of small arms (see photograph) in the factory confines at Enfield.

In 1894 the eight-hour day was introduced in Government works, the factory working 48 hours per week instead of 56. During this year the Royal Small Arms factory at Bagot Street, Birmingham, was closed, after functioning for about a hundred years. Work was transferred to the Government factory at Sparkbrook which had been purchased some ten years earlier from the National Arms and Ammunition Company. This firm had been engaged in making Mauser rifles on quite a big scale for Germany. At the beginning of the twentieth century requirements for the South African campaign kept the Enfield factory busily employed. Manufacture was largely of the long Lee-Enfield rifle and conversion of other weapons to bring them into line with this new British Service arm.

The outbreak of the Great War in 1914 brought the factory face to face with production problems which had never before arisen. Fortunately the factory was engaged on a high output before the war started, and its plant was in excellent order and ready for expansion. In consequence it was able to do much towards the immediate partial relief of the serious shortage of rifles, now required for the rapidly expanding British Army. War-time production was principally of the Short Lee-Enfield rifle, and over 2 million were made between August, 1914, and November, 1918.

In the period between the two World Wars, much experimental work was carried out at Enfield, including that connected with the development of the No. 4 Rifle. When this weapon was put into mass production following the outbreak of World War II, it was practically divorced from Enfield, where capacity was almost entirely utilized by manufacture of Bren light machine-guns, magazines, and Enfield .38-in. pistol revolvers. The weekly output of these weapons reached 1,000 Bren guns, 10,000 magazines, and 1,000 pistols.

Much useful work in connection with the new rifle was, however, carried out by the Small Arms Inspection Department at Enfield. Many of the earliest of the No. 4 Rifles, which had been made elsewhere, had many "teething troubles", and were brought to Enfield for inspection and rectification by the Chief Inspector of Small Arms' examiners before being passed to the Army. Many tests were also carried out with alternative patterns of rifle components, designed to ease production "bottlenecks", before they were approved for manufacture. Throughout the war, troubles in the Services were responsible for many defective small arms being sent to Enfield, where investigation was invariably carried out by C.I.S.A. staff.

The peak employment figure at the Royal Small Arms Factory was reached during the war when 6,315 people were employed. An event which, in normal circumstances, would have evoked con-

siderable public interest took place in November, 1942. This was the visit of Lieut. Ludmilla Pavlichenko, a Russian woman sniper who had gained much fame on the Russian Front and was credited with many successes against the Germans. In the presence of several high ranking officers of the British Army and Technical Services Lieut. Pavlichenko was shown the capabilities of a British sniping rifle on the range at Enfield, and was afterwards presented with a complete No. 4 Sniper rifle equipment.

The B.S.A. Company at Birmingham has for many years been associated with the production and repair of Lee-Enfield rifles. In 1857 they were manufacturing the Muzzle-loading Enfield Rifle, and nine years later were engaged in converting it into the first British Breech-loader, the Snider-Enfield. Government contracts for the manufacture of the Martini-Henry were placed with the firm in 1870, and in 1888 they were making the Lee-Metford Magazine Rifle. During the South African campaign, when the Long Lee-Enfield Magazine Rifle was the principal British Service arm, the B.S.A. factory at Small Heath, Birmingham, attained a production of 2,500 rifles per week and, in view of the limited capacity of the factory at that time, this was considered to be a wonderful performance. In 1903 production of the new British Service rifle, the Short Magazine Lee-Enfield, was commenced; and four years later the firm were making rifles for eventual issue to the new British Territorial Army. For some five years prior to the 1914-18 War the factory output of Service rifles was only about 7,000 per annum, and work was largely centred on making sporting and target-shooting weapons.

With the outbreak of war came a rapidly increasing demand for rifles, and production quickly stepped up to about 10,000 per week. At the beginning of World War II substantial orders were placed by the British Government for the newly-approved No. 4 Rifle. This was made at the factory at Shirley, and later the No. 5, No. 7 and No. 8 Rifles were made there. Meanwhile the Company's weapon production suffered a severe blow when, towards the end of 1940, the main factory at Small Heath was twice badly blitzed by German bombers. It was, however, principally the manufacture of anti-tank rifles which was seriously affected by the bombing, and production at Shirley received no serious interruption. At the peak period of No. 4 Rifle production at this factory, about 6,000 were being made per week, and the firm's total war-time output of rifles was about $1\frac{1}{4}$ million. The B.S.A. Company had other factories engaged on making weapons and, despite Hitler's bombs, they continued making and repairing the No. 1 Rifle at Small Heath. Throughout the war they maintained an excellent standard of barrel production and most of the No. 4 Rifles which were converted to Sniper Equipments were of B.S.A. manufacture.

CHAPTER XVII

MOSTLY POST-WAR DEVELOPMENTS

AFTER the war steps were taken to improve the general standard of the No. 4 Rifle; the British Army, quite justifiably, wanted a better-looking weapon. Certain fabricated components of wartime manufacture were soon declared obsolescent, indicating that no more were to be made. The pressed steel type of backsight was replaced by the solid Mark I pattern; manufacture of the two-grooved barrel ceased; a new short-bladed sword bayonet superseded the spiked pattern, and the external appearance of the weapon gradually improved.

A considerable amount of trouble had long been experienced in manufacture, in repair programmes, and in the Service with the trigger pulls of both the No. 4 and No. 5 Rifles. The principal difficulty had been in obtaining a pull-off which would remain constant at the required weight and not need frequent adjustment. This was usually attributable to improperly seasoned wood which was used for rifle furniture, and was seldom free from movement. Swelling and contraction of the wood acted on the trigger-guard, to which the trigger was attached. This influenced the relative positions of trigger and sear, and usually altered the weight and length of the pull-off. It was a condition which was likely to continue while existing stocks of timber were being used up. The problem was carefully investigated, and eventually a modification was suggested to remedy the weakness. This was to mount the trigger in such a way that it would be independent of the woodwork and not influenced by its vagaries. By anchoring the trigger to the body of the rifle the major, and most frequent, cause of the trouble would be removed. The most favoured method involved the attachment of a bracket to the front face of the butt socket; the trigger being mounted on the bracket. Although a complete redesign of the trigger mechanism was desirable, it was felt necessary to incorporate a modification which would not involve the loss of the large number of rifle body forgings which were in stock at the factories. On 3rd December, 1946, it was decided to manufacture fifty No. 4 and fifty No. 5 Rifles embodying a bracket to hold the trigger,

brazed to the body, and subject them to special examination, tests, and firing trials. Towards the end of 1947 comprehensive trials were carried out and the results were most satisfactory. Trigger pressures remained practically constant throughout, and the greatest variation recorded was only $\frac{3}{4}$ lb., which occurred with two weapons. It was eventually decided that the trigger bracket should be integral with the body of the rifle but, where rifle bodies or body forgings had already been manufactured, attachment of the bracket by brazing should be adopted. On 31st March, 1949, the modification was introduced and was described as: "The trigger hinged about a pin located in a bracket forged integral with the body." New rifles now became the No. 4 RIFLE, MARK II. As a new system of weapon nomenclature had now been adopted in the British Services, rifles which were modified were re-named as follows:

The Mark I Rifle became the Mark I/2.

The Mark I* Rifle became the Mark I/3.

The Mark I(T) Rifle became the Mark I/2(T).

Rifles in the Service were modified when they were returned for factory repair. Fitting the new, or modified, body entailed modifications to the rear of the stock fore-end and the trigger-guard.

The seasoned timber situation continued to show little improvement and suggestions were made that further relaxations were necessary. It was reported that approximately 30 per cent of fore-ends were being thrown away at the factories; owing to the poor quality wood it was found impossible to obtain the necessary bearings for correct stocking-up. A proposal for the omission of bearings at the reinforce and draws was put forward on the grounds that it was better to have no bearings at these points than to have bearings which continually fluctuated. This suggestion was not approved and no relaxations were granted. To make it easier for the manufacturers to get a good bearing at the muzzle end it was eventually decided to amend the drawing of the stock fore-end to allow an extra .026 wood at this point. Stocking-up troubles persisted and the quality of available woodwork showed little improvement. In 1946 a careful analysis of accuracy acceptance shooting at the factories was kept, and revealed a large number of rifles shooting high, right and left, in that order of magnitude. As a result of this analysis the tolerance on the muzzle bearing was increased from 3-5 lb. to 3-10 lb., and a higher block band was introduced in 1952. The new block-band was .06 in. higher, and its object was to compensate the effect of the increased weight of muzzle bearing.

A new method of stocking-up the No. 4 Rifle by using steel shims emanated from India, and was put forward for consideration in the U.K. as a suitable alternative method for the Sniper Rifle. It was easy to achieve and had been found particularly effective in main-

taining rifle accuracy over a long period. The method embodied a new bearing between barrel and stock fore-end at a point about 5 in. forward of the rear of the reinforce. The normal body and reinforce bearings (see Chapter XIII) were maintained, but the muzzle bearing was dispensed with; the barrel being free from any woodwork influence forward of this new centre bearing. Trials lasting from October, 1952, until February, 1953, were carried out by the Inspectorate of Armaments Testing Section Staff at Enfield Lock, and included accuracy shooting, and "weathering" trials in which the weapons were at intervals subjected to artificial rain. Forty rifles were submitted to the tests and they were stocked-up in eight different ways, which were as follows:

- (a) Five rifles were stocked by the new method, known for the purpose of the trial as "Ishapore" stocking.
- (b) Five had "Ishapore" (steel shims) stocking but no reinforce bearing.
- (c) Five had a wood bearing, $1\frac{1}{2}$ in. in length, beginning 6 in. forward of the rear of the reinforce. The fore-end was built up at this point by a wood insert glued in position. It was called the "India" type of stocking.
- (d) Five had "India" stocking and no reinforce bearing.
- (e) Five had a modified type of "India" stocking with the bearing commencing $5\frac{1}{4}$ in. forward of the rear of the reinforce.
- (f) Five had (e) stocking without a reinforce bearing.
- (g) Five had the normal Sniper rifle stocking.
- (h) Five had normal war-time stocking, without a muzzle bearing.

The results of the trial were by no means conclusive, but two facts did emerge. The "Ishapore" stocking showed no improvement on the normal Enfield Sniper standard stocking, and it was found difficult to retain the necessary pressure on the steel shims. Vibrations from firing gradually drove the shim-retaining points deeper into the fore-end, thus reducing the height of the shim and rigidity and pressure of the bearing. The trial also established that the war-time stocking (without muzzle bearing) was definitely inferior to the other methods both in accuracy and maintenance of zero. It was eventually decided that, although the "Ishapore" method was satisfactory, it showed no improvement on the normal Sniper stocking, and did not warrant the introduction of another component, i.e. the metal shim. Further experiments with "India" type stocking established the method as being entirely satisfactory and it was eventually adopted by the National Rifle Association as an alternative for stocking-up the No. 4 Rifles used by its members in competitive target shooting (Fig. 27). Since its adoption, it has steadily grown in popularity in target-shooting circles as it is believed to be



PRODUCTS OF LITHGOW (AUSTRALIA)

Top: No. 1 RIFLE (S.M.L.E.) MARK 3 used by the Australian Forces for nearly fifty years. *Centre:* SHORTENED AND LIGHTENED No. 1 MARK 3 RIFLE. An experimental model, intended for Jungle fighting, but not adopted. *Bottom:* SHORTENED AND LIGHTENED No. 1 MARK 3 RIFLE. Designed for Jungle fighting, this model was adopted for the Australian Forces but was not put into production owing to the war ending. It would have become the No. 6 RIFLE (AUST.).



THE AUSTRALIAN No. 1 RIFLE SKELETONIZED

For purposes of teaching, etc., parts of the rifle have been cut away to reveal the working of the action, etc.



DIRECTORATE OF INSPECTION OF ARMAMENTS PATTERN ROOM AT R.S.A.F.
ENFIELD LOCK

In the background, in rifle racks, are the sealed patterns of all approved and experimental British Service Rifles.



INFANTRY MODEL.



MATCH MODEL.

THE No. 8 .22-in. RIFLE

The shorter rifle shown above was chosen for the British Army and the Match Model never went into production. There were many who considered this a mistaken choice. Although the Infantry Model was a great advance in accuracy on any .22-in. rifle previously issued to the Service, the longer weapon was the more accurate and gave very close grouping at 100 yards.

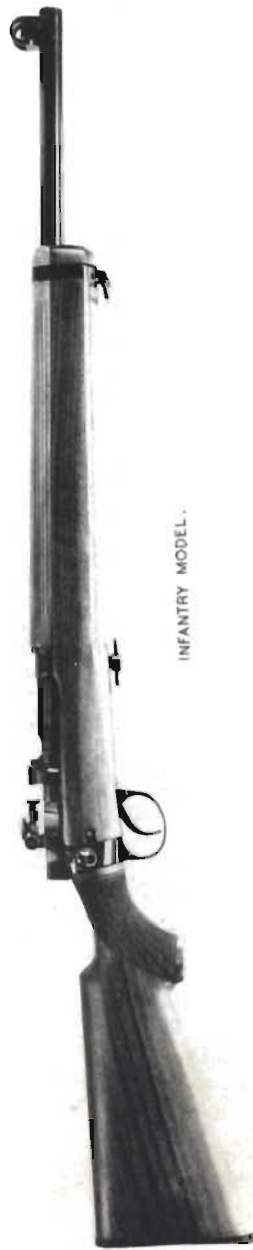

INFANTRY MODEL.



MATCH MODEL.

THE No. 8 .22-in. RIFLE

The Match Model (not adopted) is shown fitted with special Match sights. These can also be fitted to the Infantry Model. The No. 8 Rifle has been responsible for a big increase in enthusiasm for .22 target shooting in the British Army.

less influenced by sling pull than the older methods of stocking-up. Which is the best, however, still remains a very open question.

When the No. 4 Rifle was put into mass production the same breeching-up angle as used for the No. 1 Rifle was included in the drawings. "Breeching-up" is the term applied to the operation of fitting the barrel to the body; and the breeching-up angle is the relative position of barrel and body in the hand-tight position, before the application of mechanical aid to complete the operation. The angle on the drawings was $10-14^\circ$ and, whereas this had been satisfactory with the fitted screw threads on the No. 1 Rifle, the toleranced threads necessary for mass-production of the No. 4 Rifle generally gave a smaller breeching-up angle. Due to the tolerances, the flanks of the screw threads on barrel and body were not necessarily engaged unless the effective diameters were at or near the top limit, and top limit mating threads rarely occurred in manufacture. This trouble first came to light in 1942 and, for a short period, thin metal washers were used between the barrel and body breeching-up faces. Tighter breeching-up was afterwards obtained by allowing

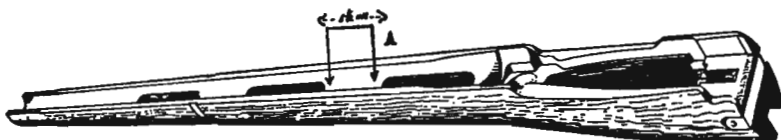

FIG. 27. Rifle No. 4. The Centre Bearing.

The correct position for the centre bearing ("India" type stocking) is shown at "A". A centre bearing in any other position is not permitted under National Rifle Association rules.

extra metal to be left on the breeching-up shoulder on the barrel. This was in most cases satisfactory but, due once again to the thread tolerances, the breeching-up angle was now in the range of $18\frac{1}{2}-31\frac{1}{2}^\circ$. This gave considerable variation in the load that had to be applied to complete the breeching-up operation and, in the worst condition (the highest angle condition), was liable to subject the screw threads and barrel socket in the body to undue strain. A considerable number of rifles with slightly bulged chambers were being found in the Service and it was thought that these could have been the result of excessive force used in breeching-up; the chamber metal being longitudinally strained so that it stretched during firing. An angle of $18\frac{1}{2}^\circ$ at the hand-tight position was considered essential for satisfactory breeching-up. Arising from a recommendation by the Inspectorate of Armaments for a standard breeching-up load, the shoulder of the barrel was machined back by approximately $\cdot 10$ in., and a series of washers $\cdot 10$ in. thick, graded in successive increases of $\cdot 001$ in., were provided. Selection of a correct sized washer gave a breeching-up angle within the

required limitations. The standard load for correct breeching-up using the modified barrel and selected washer was considered to be 120 lb. plus or minus 5 lb. Trials with rifles breeched-up in this manner gave a high standard of consistent shooting. Barrels were now interchangeable and no distortion of screw threads took place in breeching-up. The method was officially adopted in 1956.

Since its formation in 1860, the National Rifle Association has been closely associated with the British Service Rifle, and for many years had its representative on the War Office Small Arms Committee. This close association has often proved of great value to those responsible for the development of rifle and cartridge for the Services, and much useful information has been forthcoming from the annual prize meetings at Bisley. Many weapon trials have been carried out on the Bisley ranges, especially during the two World Wars, the results of which have provided the answers to numerous Lee-Enfield problems. The renewal of the National Rifle Association Prize Meetings after the Second World War saw considerable interest centred on the performance of the No. 4 Rifle as a target-shooting weapon. For a time only limited supplies were available for private sale but, as more came into use and gunsmiths became better acquainted with methods of stocking-up, it was soon established as a very accurate rifle. It gradually superseded the No. 1 Rifle, especially at the shorter ranges, i.e. 200 to 600 yards. For some time the No. 1 Rifle continued in favour for long-range shooting, i.e. 900 and 1,000 yards, and it still has many adherents. It was considered to be the more accurate rifle at these distances due to compensation, but this assertion is not substantiated by any official records. The only compensation trials carried out with the No. 4 Rifle were before its adoption (see Chapter XII) and were very inconclusive; and changes in methods of stocking-up, etc., have taken place since those days. With a view to improving the accuracy of the No. 1 Rifle and bringing it more into line with the No. 4 in the matter of barrel weight, a heavier barrel was permitted for use under N.R.A. rules. It was the same length as the normal barrel but weighed 2 lb. 13½ oz. In some cases it has improved the accuracy of the rifle to which it has been fitted, in others it has been found of little advantage. Since its introduction to target shooting between the two World Wars, the No. 3 Rifle (described in Chapter XI) has always been the favourite of many Bisley competitors. Although not considered as comfortable to hold as the Lee-Enfield rifles, it has maintained a high standard of accuracy and, due to its front locking action, is less affected by the higher pressures resulting from water in the chamber, which often occurs in "wet weather" shooting. Of recent years the number of No. 3 rifles on the ranges has steadily declined owing to decreasing stocks of replacement barrels. The respective numbers of the three

members of the Enfield family of rifles now used at Bisley is reflected in the official return of those used by the hundred competitors in the Final Stage of the Queen's Prize for 1958. They were:

No. 4 Rifle	61
No. 1 Rifle	36
No. 3 Rifle	3

It is most probable, however, that the number of No. 4 Rifles now in general use at Bisley is rather higher than 61 per cent. It is interesting to note that the 1958 winner, Major Robin Fulton, although using a No. 1 Rifle in the Final Stage, had reached the last "Hundred" with a No. 4. The N.R.A. records show that the first marksman to win the Queen's Prize at Bisley with a Lee-Enfield rifle was probably Private Ward of the 1st V.B. Devon Regt. in 1897.

The future of Lee-Enfield rifles is very much in the "melting-pot". It seems almost certain that in a few years' time a number will be converted for target-shooting purposes to fire the new British and NATO 7.62-mm. rimless cartridge. It is considered that there is a stock of .303 in. cartridges sufficient for a few years' target shooting. Just how many rifles may be converted depends on the future policy of the War Office regarding the possible arming of Reserve Forces with the F.N. Automatic Rifle. A large number of Lee-Enfield rifles have been sold by the Ministry of Supply as surplus stores, and it is interesting to note that thousands of them are being converted into sporting rifles, and thus being given a new lease of life. They are being readily sold in the United States and other countries where weapon restrictions are few and game shooting plentiful. The mud of Ypres and the Somme, the sands of Mesopotamia and Alamein, and the swamps and jungle of Malaya and Burma proved the Lee-Enfield second to none as a Service rifle. If it performs as well as a "Sporter" as it has done as a weapon of war, it will make many friends amongst the shooting sportsmen of America.

CHAPTER XVIII

THE AUSTRALIAN STORY

FOR about fifty years Australia has played an important part in the development and manufacture of Lee-Enfield rifles, and can be justly proud of her achievements in small arms production. The Federation of the States and establishment of the Commonwealth in 1901, vested in the new Government the responsibility for the development of manufacturing facilities for the country's defence. Prior to 1900, practically all defence material had been supplied by the United Kingdom and, during the South African campaign, it became apparent that Australia's comparative isolation from the sources of arms supply could lead to serious logistic problems in any future conflict. In 1907 the decision was made to establish a factory for the manufacture of small arms in the Commonwealth.

The site chosen for the new factory was at Lithgow, on the western foot-hills of the Great Dividing Range. It was about ninety miles west of Sydney, and the principal factors influencing its choice were the existence in the town of steel works and a thriving coal industry. It was also considered to be far enough away from the coast to be safe from any naval bombardment. The site was finally approved following a visit by Lord Kitchener in 1909, and building commenced almost immediately. Tenders for the supply of a complete plant, with which to manufacture Lee-Enfield rifles at the rate of 250 per week, were invited from the United Kingdom, several European countries, and the U.S.A. The order was eventually secured by the Pratt and Whitney Corporation of America. The contract was for the supply of all machine-tools, jigs, fixtures and gauges; and the company equipped the factory for rifle manufacture with considerable skill and ingenuity, applying the best principles of the day towards quantity production with semi-skilled labour. The company also supplied foremanship training at their works in America for six Australian tradesmen, and provided the first manager at Lithgow. The new factory was formally opened on 8th June, 1912, and the first rifle to be made was the Short Magazine Lee-Enfield, Mark II (see pages 189, 191 and 193). This

PLATE "A"

Rifle, No. 1, Mark III, S.M.L.E., .303 in. (with cut-off).

- A. Barrel, Body and Bolt, Breech Assemblies.
- B. Magazine "B" and Stock Assembly.
- C. Bayonet, No. 1, Mark I, Scabbard, Bayonet, No. 1, Mark II.

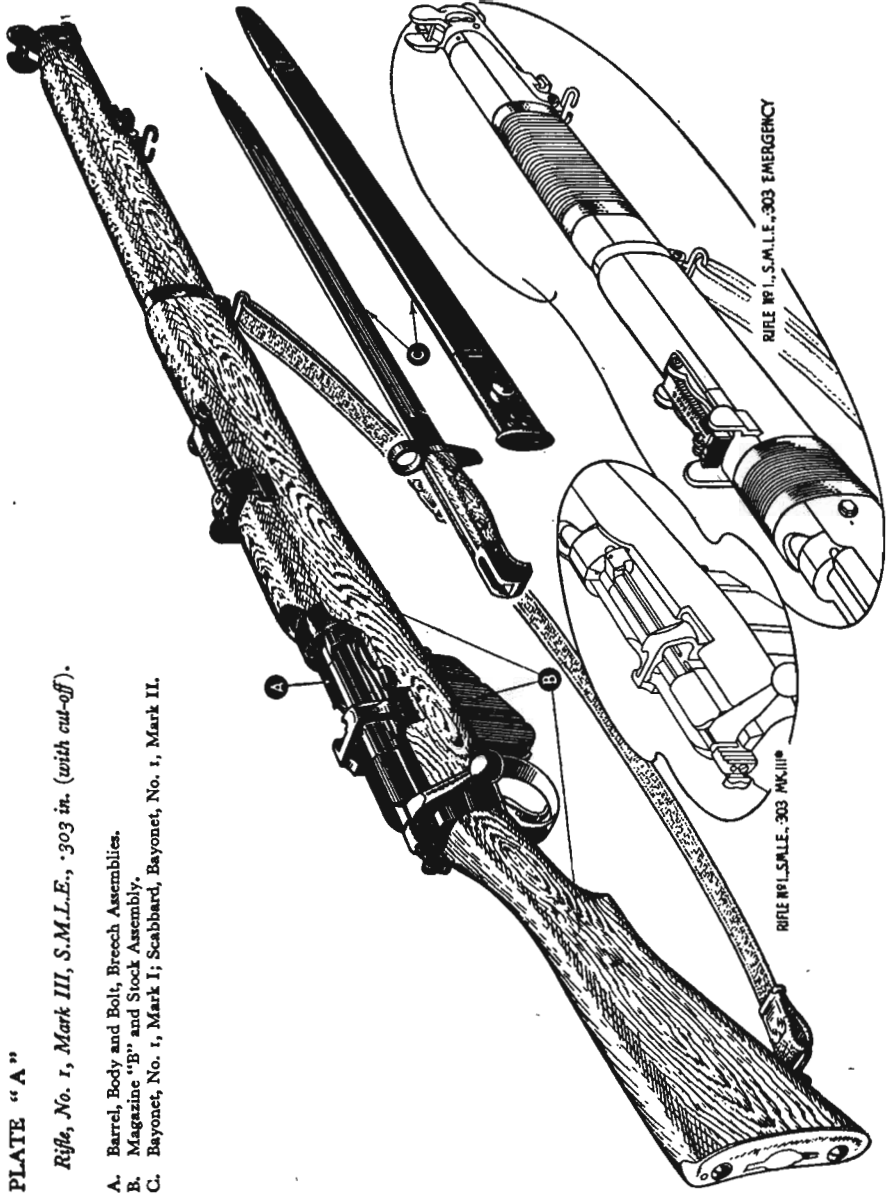

was the current British Service weapon; the Australian Forces having previously been armed with the Long Lee-Enfield rifle. The Lithgow factory had a total floor space of just under two acres and, when manufacture first commenced, employed 190 people. It was at that time the most up-to-date manufacturing concern in Australia, having its own power house, forge shop and tool-room.

The first forty rifles were completed by May, 1913, and, immediately following the outbreak of war in 1914, production rose to 1,600 rifles per week and the number of employed persons to 1,400. Between the two World Wars, production and employment dropped considerably but, from 1925 to 1930, building extensions were carried out to provide capacity for making the Vickers Sustained-fire machine-gun. During 1938 and 1939 further extensions were made to facilitate increased production of rifles and Vickers machine-guns, and to establish capacity for the manufacture of the Bren light machine-gun. New plant was procured to bring the factory equipment up to modern standards, and it is of interest to note that 90 per cent of the 850 machines then engaged on rifle manufacture were made by Pratt and Whitney.

On the outbreak of war in 1939, manufacture of all small arms was concentrated at Lithgow. Following the evacuation of Dunkirk in 1940 the Australian authorities received an urgent request from the United Kingdom for as many No. 1 rifles as could possibly be spared. Consequent on Dunkirk losses and the growing threat of invasion, rifles were badly needed in the U.K. and some 30,000 weapons were immediately despatched from the Commonwealth to aid the Mother Country. This was a particularly praiseworthy effort as it severely taxed the efficiency of the Australian Army to have so many weapons suddenly withdrawn from service. Action was then taken to expand Australian rifle production by erecting a new factory at Bathurst, some forty miles west of Lithgow. This factory, which began production in 1941, was established in an agricultural area which had no record of previous industrial experience. Despite this, an output of 2,000 sets of rifle components per week, plus the necessary spares, was achieved within a short time of opening; barrel manufacture and assembly of the weapons being carried out at the parent factory at Lithgow. Almost immediately following the opening of the Bathurst factory, the Australian Army requested an increase in production to 4,000 rifles per week, and it was decided to duplicate the Bathurst installation at Orange, some forty miles further west, again in an area where only unskilled labour was available. This plant was improved by the addition of barrel-making capacity, and only the assembling of rifles was carried out at Lithgow; this latter factory being otherwise free to concentrate on making Bren and Vickers machine-guns and tools for all the various other projects. The increased demand for rifle woodwork in

PLATE "B"

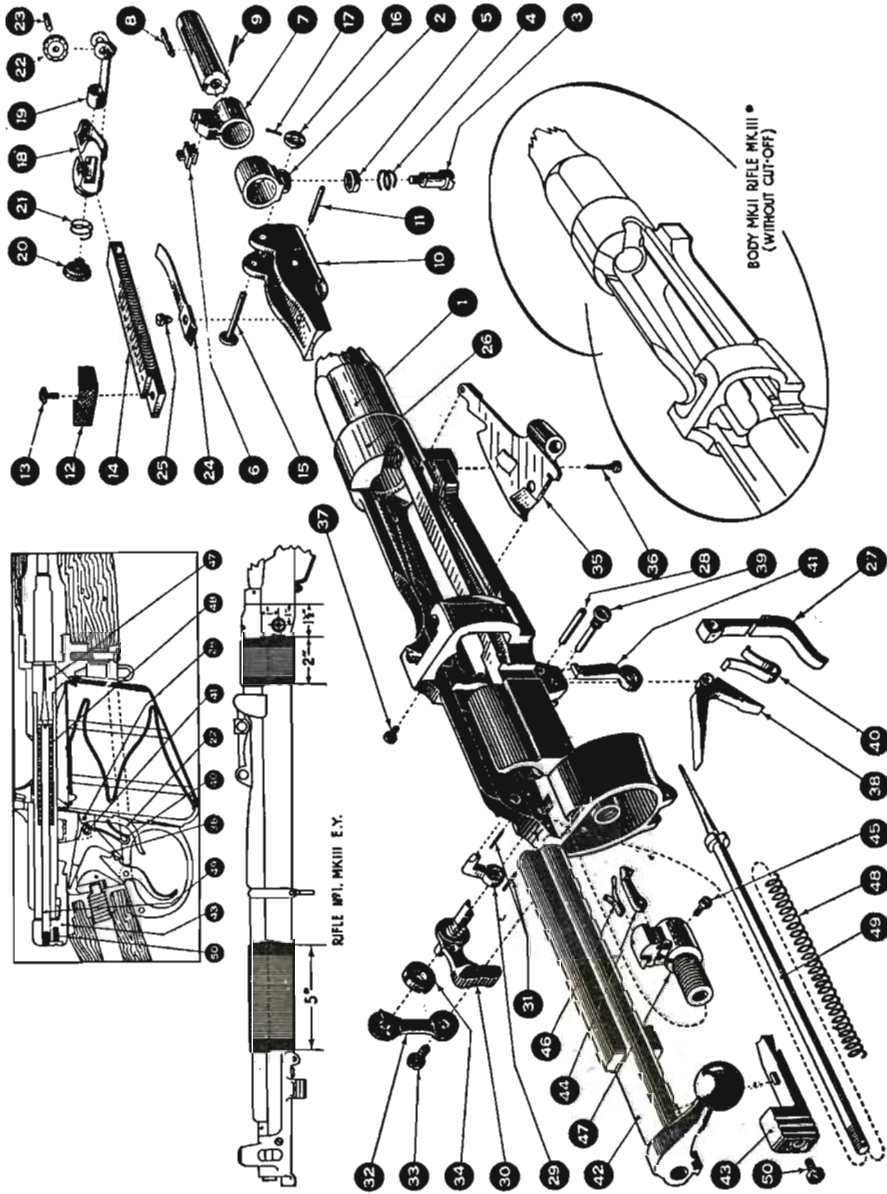

- BARREL ASSEMBLY.** 1. Barrel, without body, with sights. 2. Band, inner. 3. Screw. 4. Spring. 5. Washer. 6. FORE-SIGHT. 7. Block, band. 8. Key. 9. Pin, fixing. **BODY ASSEMBLY.** BACKSIGHT. 10. Bed. 11. Pin, fixing. 12. Cap. (b) Cap, backsight, (Aust.). 13. Screw (c) Screw, cap, backsight, (Aust.). 14. Leaf, "B". (d) Leaf, backsight, (Aust.) Notes (b), (c) and (d) are used on Rifles manufactured since 1943. 15. Pin, axis. 16. Washer. 17. Pin. 18. Slide. 19. Catch. 20. Screw. 21. Spring, sight back. 22. Pin. 24. Spring, sight back. 25. Screw. 26. Body. 27. Catch, magazine. 28. Pin. 29. Catch, safety. 30. Bolt, locking. 31. Pin, stop. 32. Spring, Mk.I Also Spring, Mk.II. 33. Screw, Mk.I. (b) Also Screw, Mk.II. To be demanded as Screw, cap, backsight (Cat. No. BB 0726). 34. Washer, Mk.I. (c) Also Washer, Mk.II. Notes (e), (b) and (c) are used on Rifles manufactured since 1943. 35. Cut-Off. 36. Screw. 37. Screw, ejector. "B". 38. Sear. 39. Spring. 40. Spring. 41. Spring, retaining. **BOLT BRECH ASSEMBLY.** 42. Bolt. 43. Cocking-Piece, "B". 44. Extractor. 45. Screw. 46. Spring. 47. Head. 48. Spring, main. 49. Striker "B". 50. Screw.

1941 was met by the establishment of an annexe at the factory of Slazengers (Aust.) Pty. Ltd., near Sydney. In order to take advantage of hitherto untapped resources of unskilled labour, small feeder factories were established at the country towns of Forbes and Wellington during 1942. These were for making rifle components which were afterwards assembled into weapons at the Orange factory. Other feeder factories were established at Mudgee, Cowra, Young, Parkes, Dubbo and Portland; all being within 150 miles of Lithgow. By 1943, employment at Lithgow had risen to 6,000, and a further 6,000 were employed at Bathurst, Orange, and the feeder factories; a weekly production rate of 4,000 rifles, 150 Bren, and 50 Vickers machine-guns being achieved at this period. From 1944 onwards production was curtailed and, during the following two years, all factories were closed except the parent factory at Lithgow. When production of the Lee-Enfield ceased in 1955 with the assembly of Rifle No. F.40580, a total of 640,000 rifles had been made in Australia, 415,580 of these since 1939.

The present factory at Lithgow covers an area of forty acres, with a further ninety acres occupied by testing ranges and residences for the staff. Although manufacture of the Short Magazine Lee-Enfield Rifle (the No. 1 Rifle) has now ceased, probably for all time, reconditioning and repair work goes on. Spare parts for the Lee-Enfield are still being made and heavy rifle barrels for the target-shooting enthusiasts of Australia and New Zealand. The factory is being equipped and re-arranged for production of the 7.62-mm. F.N. Rifle, which is replacing the Lee-Enfield. The completion of this re-equipment programme in approximately 1960 will establish the Lithgow factory as one of the most modern of its type in the world.

In nearly fifty years of manufacture in the Commonwealth the Australian S.M.L.E. has differed little from the British pattern, except in the following particulars:

1. Australian Coachwood has been used for practically all rifle furniture, only a small number of weapons being assembled in Queensland maple. Coachwood (*Ceratopetalum Apetalum*) is an indigenous timber of pleasing appearance and handling, and possesses most of the requisite characteristics for rifle furniture. It is considered to be easier to machine than walnut but not quite as stable, and rather more prone to splitting.
2. Copper blocks were fitted at the draws in the stock fore-end to act as recoil shoulders. (See Plate "C," 51).
3. Screws made from brass rods were used for strengthening the fore-end and the front and rear hand-guards.
4. The stem of the stock-bolt was made parallel for its full length. (See Plate "C," 36).

PLATE "C"

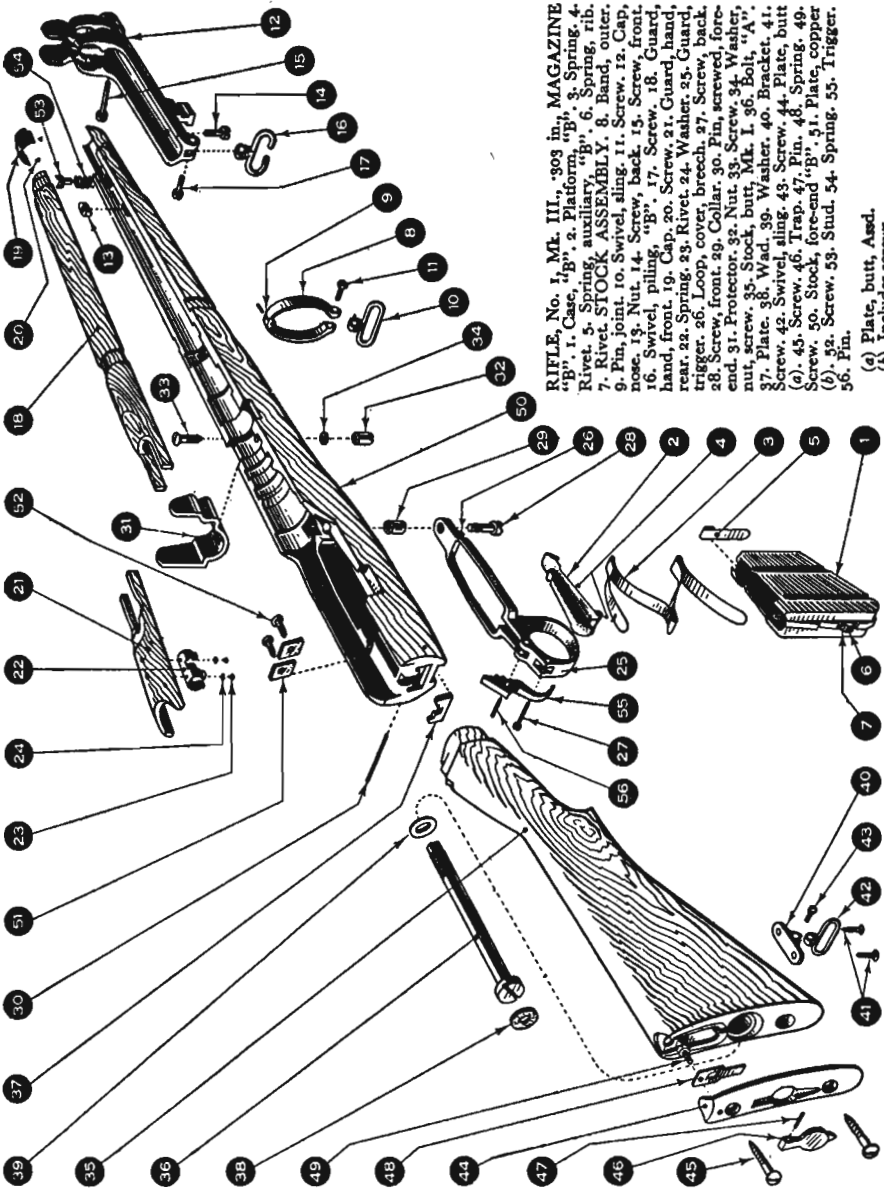

RIFLE, No. 1, M1. III., .303 in., MAGAZINE
 "B". 1. Case, "B". 2. Platoon, "B". 3. Spring, 4.
 Rivet. 5. Spring, auxiliary, "B". 6. Spring, rib.
 7. Rivet. STOCK ASSEMBLY. 8. Band, outer.
 9. Pin, joint. 10. Swivel, sling. 11. Screw. 12. Cap,
 nose. 13. Nut. 14. Screw, back. 15. Screw, front.
 16. Swivel, piling, "B". 17. Screw. 18. Guard,
 hand, rear. 19. Cap. 20. Screw. 21. Guard, hand,
 rear. 22. Spring. 23. Rivet. 24. Washer. 25. Guard,
 trigger. 26. Loop, cover, breech. 27. Screw, back.
 28. Screw, front. 29. Collar. 30. Pin, screwed, fore-
 end. 31. Protector. 32. Nut. 33. Screw. 34. Washer,
 nut, screw. 35. Stock, butt, Mk. I. 36. Bolt, "A".
 37. Plate. 38. Wad. 39. Washer. 40. Bracket. 41.
 Screw. 42. Swivel, sling. 43. Screw. 44. Plate, butt
 (a). 45. Screw. 46. Trap. 47. Pin. 48. Spring. 49.
 Screw. 50. Stock, fore-end "B". 51. Plate, copper
 (b). 52. Screw. 53. Stud. 54. Spring. 55. Trigger.
 56. Pin.

(a) Plate, butt, Assd.
 (b) Includes screws.

5. Brass identity discs were omitted from the stock-butt.

Since the early days of World War II the following modifications to ease production were incorporated:

1. The foresight adjustment windows in the protector lugs on the nose-cap were omitted.
2. The piling swivel was left off and the swivel lug not machined.
3. The lightening cuts in the backsight protector were omitted.
4. Pressure die castings were used instead of forgings for the butt-plate, inner and outer bands, and swivel bracket.

The original Enfield form of thread was retained in all the S.M.L.E. rifles made in Australia. This is a special form of thread differing from all other thread standards. It was also used in the U.K. in Lee-Enfield rifles prior to the manufacture of the No. 4 Rifle.

The method of accuracy testing in the Commonwealth was similar to that employed in the U.K.; acceptance or rejection being in the hands of a separate Inspection Staff of the Department of Supply.

The test was as follows:

1. *On the 100-ft. indoor range*, with sights set for the 200 yards distance, test rounds were fired to enable any necessary foresight adjustments to be assessed and made; the maximum permissible lateral deviation of the blade from the centre of the foresight block being .03 in. At this stage, vertical errors were also corrected by fitting a blade of the requisite height. Five rounds were then fired to test the accuracy of the rifle. These were fed into the chamber from the magazine, and thus functioning of the magazine was simultaneously tested. At least four of the five rounds were required to group within a rectangle measuring 1 inch horizontally by $1\frac{1}{2}$ inches vertically, the mean of the group having to be approximately 1 inch up from the point of aim. For these tests the rifle was fired from an Enfield Rest.
2. *Outdoor range*: 10 per cent of all rifles made were fired at 200 yards. Two shots to warm the barrel were followed by seven for group, six of which had to be in an 8-in. square; 10 per cent of these rifles were then fired at 600 yards, where the acceptance standard was six out of the seven shots fired to be within a 24-in. square. All the rounds fired in these tests were fed into the chamber from the magazine.

When the Short Magazine Lee-Enfield Rifle was introduced in the Commonwealth, members of Australian Rifle Clubs were reluctant to adopt it for target shooting. It was considered that the light barrel would be prone to excessive vibration and consequent inaccuracy in shooting. Whereas in the U.K. a special form of

stocking-up, embodying packing the barrel in the woodwork to damp down the barrel vibrations, was permitted, target shooters in Australia were allowed to fit a heavier barrel. This was developed and made at Lithgow and was, in fact, a shortened version of the Long Lee-Enfield barrel. The assembled rifle differed from the Service arm in that the barrel was bedded in the stock fore-end and clamped by the front trigger-guard screw and the nose-cap. The inner band, spring and screw, and the stud and spring of the nose-cap were omitted from the target rifle. The heavy barrel was accepted as a standard for Rifle Club use in Australia and New Zealand, and teams and competitors visiting the U.K. were permitted to use it at the National Rifle Association's Imperial Meeting at Bisley where it has gained many noteworthy successes, Mr. P. A. Pavey of Australia winning the King's Prize with one of these rifles in 1948. It was never a general service issue, but 2,500 heavy barrelled rifles were equipped with Pattern 1918 telescope sights and issued to Australian snipers during World War II. They were extremely popular with the snipers and received high praise for outstanding accuracy.

The No. 4 Rifle was never manufactured in the Commonwealth, although about 2,000 were issued to certain ground staff units of the R.A.A.F. and the 1st Australian Infantry Troops Workshop, A.E.M.E., for training purposes. These had arrived in Australia as refugee cargo, from a ship diverted from Eastern ports as a consequence of Japanese victories. They were of Canadian manufacture and fitted with two-grooved barrels.

In 1942 a request for a lighter rifle for jungle fighting came from the Australian Forces fighting in New Guinea. The requirement was realized but development was hampered by the fact that total tool-room capacity was devoted to the S.M.L.E., the Bren, and the Vickers M.G.; all of which were urgently needed by the A.I.F. Experiments took place with shortened barrels, fore-ends, hand-guards, etc., and eventually two different models were produced at Lithgow. The first to be completed was outwardly similar to the normal S.M.L.E. (see Plate, page 184) except that the barrel was shortened to $20\frac{1}{4}$ inches, and lightening cuts were incorporated in several components. It weighed about 8 lb. and was $39\frac{1}{2}$ ins. in overall length. It did not satisfy the required weight reduction, and it was not until 1944 that capacity became available for further development. The next model to be developed was a copy of the British No. 5 Rifle (see Chapter XV) which had just been adopted in the U.K. This rifle weighed $7\frac{1}{2}$ lb. (see Plate, page 184) and had a barrel $18\frac{1}{2}$ ins. long. It differed from the British No. 5 in several details. The backsight was not of the aperture type but was the same as on the S.M.L.E., and it was positioned slightly forward of the Knox-form. The flash eliminator was made to take the standard

No. 1 bayonet with a modified cross-piece, and narrow grooves were cut in the stock fore-end to assist holding. The hand-guard was finished flush with the fore-end and, to prevent splitting, the ends were strengthened with screwed brass wire. This model was adopted for the Australian Army but, with the war ending, only a small number were made and it never went into full production. Had it been manufactured in quantity, as at one time intended, it would most probably have become the NO. 6 RIFLE, MARK I (AUST.). Another lightened rifle, sometimes called the No. 6 Rifle but never officially introduced as such, was designed for Far Eastern theatres of war by the Armament Design Establishment at Enfield, England. This was a development of the S.M.L.E. (No. 1 Rifle). It weighed about 7 lb., was 39.6 in. in overall length, and was fitted with an 18-in. barrel. It was never put in production in either the U.K. or Australia.

An interesting development with the Australian S.M.L.E. took place in 1942. Machine-guns were in short supply and badly needed, and attempts were made to convert the rifle into a semi-automatic weapon. A method of conversion was submitted by Mr. Charlton, then a resident in New Zealand, in which country a number of rifles had been successfully converted. S.M.L.E. rifles were also urgently needed by the A.I.F. and it was eventually decided to convert some of the large number of weapons held for target-shooting purposes by members of civilian rifle clubs. The required rifles were impressed by the Australian Government and the work of conversion commenced. The rifles were a mixed lot, of different vintages, and the difficulty of determining their origin, and the heat treatment to which they had been subjected, made the task of conversion extremely difficult. The project was abandoned when the emergency measures, which had been taken to increase production of the Bren light machine-gun, began to take effect.

CHAPTER XIX

THE LEE-ENFIELD IN THE ·22-IN. ROLE

FOR many years target shooting with a small calibre cartridge has been regarded as a necessary form of training in the British Army. It was, and still is, a stepping stone towards the Service weapon and enables the recruit to become familiar with the weight and handling of his rifle and to learn the rudiments of accurate shooting. Facilities have usually been available at centres of training for this form of shooting, which does not present the same range problems as the full-bore ·303-in. rifle and cartridge.

The early method in the British Army of shooting with a small calibre cartridge was by means of a tube, which fitted into the bore of the Service rifle barrel. The tube was rifled and chambered for the small cartridge and allowed the rifle to be fired in the normal way. One of the earliest recorded examples was used with the Martini-Henry rifle and, on 29th December, 1891, a new pattern was introduced for the Lee-Metford rifle. This consisted of a steel tube, rifled throughout with eight grooves. The breech end was solid, and concentric with the tube, and it was chambered to suit the special aiming tube cartridge. It had a steel sliding extractor which was attached to the tube by a small steel stud, working in a cam slot, which gave a revolving motion to the sliding extractor. A gunmetal nut and washers fitted to the muzzle end of the tube kept it in position in the barrel of the rifle. Most of the aiming tubes in the British Service were known as Morris tubes. Prior to 1906 aiming tubes had been for use with a central fire black powder cartridge but, on 13th November of that year, a tube was introduced to fire ·22-in. rimfire cartridges. A number of Short Magazine Lee-Enfield rifles, including some of those which had been used in the big troop trials described in Chapter VII, were converted for this purpose. The conversion necessitated the fitting of special bolt-heads and strikers, in addition to the aiming tubes, and the converted rifles were called **SHORT MAGAZINE LEE-ENFIELD A.T., MARK I.** They were marked "A.T." (for Aiming Tube) on the body, barrel, bolt, butt and fore-end.

A big advance towards providing the British Army with a more satisfactory medium for shooting the small calibre cartridge was the introduction of the .22-in. R.F. SHORT RIFLE, MARK I, on 13th December, 1907. Instead of an aiming tube, this rifle was fitted with a new barrel specially rifled and chambered for the small cartridge, and its introduction foreshadowed the end of the aiming tube. The new weapon was a conversion of the Magazine Lee-Metford Rifle, Mark I*, which made it as near as possible the weight, length, etc., of the current Service arm, the Short Magazine Lee-Enfield, Mark III. Details of the conversion were as follows:

Body. The gas vents were enlarged.

Bolt, breech. The bolt had the cover stops and a portion of the top of the rib removed, and the cover screw holes filled in. The front end was bored to receive a threaded bush, which was fixed by a portion of the original bolt-head screw, the bush and screw being brazed in. The bush was tapped for the screwed tenon of the bolt-head.

Bolt-head. The striker hole in the face of the bolt-head was bored .0885 in. eccentric to the axis of the bolt-head, and the hole for the extractor axis screw was bored nearer to the axis of the bolt-head than for the S.M.L.E., A.T., Mark I. For identification purposes bolt-heads of this pattern were marked ".22" on top of the wing.

Striker. The striker was suitably arranged for the bolt-head and had a flat portion to clear the rear end of the extractor.

Stock fore-end. The stock fore-end was cut shorter and a liner was fitted which was glued in and suitably grooved for the smaller barrel. The dial sight seating and clearing-rod groove were filled up.

Extractor. An extractor having a long and narrow hook was fitted. It was so arranged that the outward movement was limited by the body to prevent injury to the extractor spring in the event of a burst cartridge case.

Bands. Both upper and lower bands had liners, suitable for the smaller barrel, which were fitted and brazed in.

Foresight Protector. This was fitted on the barrel, over the foresight block, and fixed by a screw.

Barrel.

Length	25 $\frac{3}{8}$ in.
Calibre214 in.
<i>Rifling.—Segmental.</i>								
Grooves—Number	8
Depth052 in.
Width05 in.
Twist	Right-hand, 1 turn in 16 in.

Sighting system—Adjustable blade foresight and radial backsight with fine adjustment and wind-gauge (as on the Service weapon).

<i>Sight radius</i>	19 $\frac{1}{2}$ in.
Length of rifle.	3 ft. 8 $\frac{1}{2}$ in.
Weight of rifle	8 lb. 4 oz.

The ammunition used in this weapon was the R.F. Aiming Tube Cartridge, Mark I. The case was made of solid-drawn copper-zinc alloy, the fold in the rim being charged with cap composition. The lead bullet weighed 39.9 grains and had three cannelures round it to retain the lubricant. The charge was 4.7 grains of black powder. To distinguish this cartridge from those used in Morris aiming tubes the letters "C.F." (central fire) were added to the latter.

On 15th December, 1910, a stronger bolt-head and a new form of striker, which was in two parts, was approved for the rifle.

On 11th November, 1911, the conversion of a number of Long Lee-Enfield rifles to .22-in. calibre was approved. The converted rifle became the .22-in. R.F. LONG RIFLE, MARK II. The barrel was special to the weapon and was bored and chambered for the .22-in. R.F. Mark I cartridge. On the adoption of this rifle, the Aiming Tube rifles became obsolescent, and thereafter gradually disappeared from the Service.

Consequent on the decision to cease manufacture of aiming tubes, an increased demand for .22-in. rifles for range target practice necessitated several conversions during the next few months. The .22-in. R.F. SHORT RIFLE, MARK I* was introduced and was a conversion of the Lee-*Metford*, Mark I*. It differed from the .22-in. R.F. Short Rifle Mark I in the sighting, which was brought into line with the recently modified sighting on the Service .303-in. rifle (see Chapter X). An easily recognizable feature of the new rifle was the foresight protecting wings which were straight vertically instead of being incurved. The Mark II pattern of this rifle was introduced on 5th January, 1912, and was a conversion from the Lee-*Metford*, Mark II. It was very similar to the Mark I*, and barrel (with sights), foresight protector, bolt-head, firing-pin, striker and extractor were common to both rifles.

On 7th February, 1912, the .22-in. R.F. LONG RIFLE, MARK I, was approved. This was another conversion from the Lee-*Metford* Mark II, and was an instance of a Mark I rifle being introduced three months later than its Mark II pattern. The conversion was on similar lines to that for the Mark II, new barrels chambered and rifled for the .22-in. rimfire cartridge being fitted. A number of Lee-*Metford*, Mark II*, and Lee-*Enfield*, Marks I and I*, were similarly converted and these became the .22-in. R.F. LONG RIFLE, MARK I*. It differed from the Marks I and II in the pattern of the bolt, cocking-piece and striker, and was fitted with a safety-catch.

On 9th August, 1912, a conversion of S.M.L.E. Marks II and II* was approved. When fitted with new .22-in. barrels these became

the .22-in. R.F. SHORT RIFLE, MARK III. The conversion was similar to that for previous Marks of the .22-in. Short Rifle, and barrels and sights were the same as on the Mark I*. In 1915 a magazine holding five cartridges was fitted.

A new form of .22-in. barrel was approved in 1915. It was actually a barrel conversion; the barrels of Service rifles being bored out and fitted with tubes rifled for the .22-in. rimfire cartridge. The bolt-head was also converted by fitting and brazing a plug into the striker hole, and boring a new hole for the firing-pin. The extractor seating was lowered. To meet the wartime needs of the rapidly expanding British Army, barrel production was stretched to capacity, and this method of producing .22-in. rifles did not interfere with the manufacture of barrels for the Service full-bore weapons. The first rifle to embody the new tubed barrel was the PATTERN 1914 .22-in. R.F. SHORT RIFLE. It was introduced on 24th May, 1915, and was a conversion of the S.M.L.E., Marks II and II*. To further increase the similarity of the .22 rifle to the Service weapon a magazine which held five .22-in. cartridges was introduced on 21st December, 1915. The fitting of this magazine necessitated slight modifications to bolt-head and extractor.

A few months earlier a new .22-in. cartridge had been approved for the British Service. This was the .22-in. R.F. NO. 1 SMOKELESS CARTRIDGE, MARK I. It had a long case with a 40-grain bullet and a smokeless propellant charge. The case was usually made of solid-drawn copper-zinc alloy, but cupro-nickel was permitted for use. The bullet was made of an alloy of lead. Its cannelures were lubricated with beeswax and it was secured in the case by crimping or coning. This cartridge heralded the end of black powder cartridges for .22 shooting in the British Army.

Two more conversions were approved on 28th April, 1916. They were:

- (a) S.M.L.E. Marks III and IV to .22-in. R.F. PATTERN 1914 SHORT RIFLE No. 2.
- (b) C.L.M.L.E. Mark I* to .22-in. PATTERN 1914 LONG RIFLE.

In consequence of the introduction of the new Short Rifle, No. 2, the earlier pattern, introduced on 24th May, 1912 (the first to embody the tubed barrel), became the .22-in. R.F. PATTERN 1914 SHORT RIFLE, MARK I. The conversions necessitated the same modifications as the earlier pattern, the barrels being bored out and tubed. In these later conversions the backsights were scribed for the 25-yd. range. A few months later the trigger actions of these rifles were converted to the double trigger pull, as on the Service weapons.

A new method of conversion was approved in July, 1918, when a number of S.M.L.E. Marks III and IV were converted into what

was called the .22-in. R.F. PATTERN 1914 SHORT RIFLE. (As has already been shown, the rifle which originally bore this name was now the Mark I.) The new pattern was adapted to take the .22-in. R.F. cartridge on somewhat different lines. The cartridge was loaded into a conveyor, which was similar in shape to a normal .303-in. round. The conveyor was chambered and bored for the small cartridge and was loaded into the magazine by charger, and afterwards fed into the rifle from the magazine in the same manner as a normal .303-in. round. Thirty conveyors were issued with each rifle. The conversion consisted of boring out the service barrel and soldering into it a tube which was rifled to suit the .22-in. cartridge. The barrel was chambered and the tube cut to the required length. This method of conversion was not popular and two years later was declared obsolete and all converted weapons were withdrawn from the troops.

The last conversion of the S.M.L.E. to .22-in. calibre was announced on 19th November, 1921. This was from a number of current Service weapons, Marks III and III*, and the new rifle became the .22-in. R.F. SHORT RIFLE, MARK IV. Solid barrels were again fitted and were dimensionally the same as on the earlier Mark III. It was, in fact, a reversion to pre-war standards. Other .22-in. rifles were brought into line with this pattern when sent in for repair. In 1926, when rifle nomenclature was altered, the rifle became the No. 2 MARK IV*, and remained in service for many years.

After the 1939-45 War, the question of a new .22-in. rifle for the British Army was raised and vigorously pursued. There was an increasing desire to provide the Services with a rifle which, whilst retaining a similarity in shape and handling to the Service .303-in. weapon, was capable of a standard of accuracy which would enable users to compete on level terms in competition shooting with members of civilian rifle clubs. .22 target shooting as a recreational pastime was becoming increasingly popular, both in the Services and in civilian rifle clubs, and a problem had arisen in a shortage of satisfactory weapons to meet the growing demands. Apart from Service requirements, very few rifles were being manufactured, and most of these were for export only. The Society of Miniature Rifle Clubs (later the National Small-bore Rifle Association) which had, since just after the Boer War, so successfully sponsored and organized .22 target shooting in the U.K., were finding it difficult to provide their clubs with sufficient rifles to keep them active. It was therefore hoped that a rifle could be developed for the Services which would also be made available to civilian purchasers and satisfy the demand for a good club rifle. With this end in view there was close liaison between the S.M.R.C. and the War Office and

Ministry of Supply departments concerned. The suggestions of civilian shooters were collated and examined by the Government designers and eventually prototype rifles were produced and tested by service and civilian marksmen, a few being distributed by the S.M.R.C. to their more prominent clubs. Finalizing the design of a rifle to meet all requirements proved a very lengthy task, and meanwhile popular target shooting rifles made by private manufacturers were becoming increasingly available. Token quantities of first-class rifles were also coming in from the United States. The final design of the weapon was one which was unlikely to be popular for civilian purchase against the known and proved patterns which could now be bought in the open market, and it eventually went into production for the Service only. An excellent rifle, especially at the shorter ranges, it never quite reached the standard of the best and most accurate target shooting weapons. The prototype weapons were made with barrels of two different lengths. Probably due to its longer sight base, the better accuracy was obtained with the longer rifle. The short-barrelled pattern was eventually chosen by the War Office. It was introduced for the British Army on 7th September, 1950, and became the No. 8 RIFLE, MARK I. Details of the rifle are as follows:

Length of rifle	41.05 in.
" " barrel	23.36 in.
Rifling: No. of grooves	6
Spiral	Right-hand
Pitch	1 turn in 16 in.	
Calibre216 in.
Weight of rifle	8 lb. 14 oz. (approx.)	
Sight radius	27.14 in.

Barrel. The barrel was shorter and heavier than that on the No. 4 Rifle. The rifling was tapered, being deepest at the breech end and running out to almost bore diameter at the muzzle. The tapered rifling was designed to give an improved gas seal and remove the initial engraving from the bullet by the time it left the muzzle. This was done to improve the standard of accuracy with varying brands of ammunition. The chamber had a plain taper and the breech face was counter-bored to take the rim of the cartridge. It was further counter-bored for the rim of the bolt-head.

Body. The body was similar to that of the No. 4 Rifle, with certain internal machining operations omitted. The bolt-way was bored larger at the front end for the projecting breech end of the barrel. The lower part of the body was widened to accommodate the cartridge platform. The left side of the body was tapped for fitting a special match backsight.

Trigger mechanism. The trigger mechanism could be adjusted to give either the regulation service double pull-off, or a single pull-off as on most .22 target rifles. The pulls could be adjusted for length and weight. (Figs. 28 and 29.)

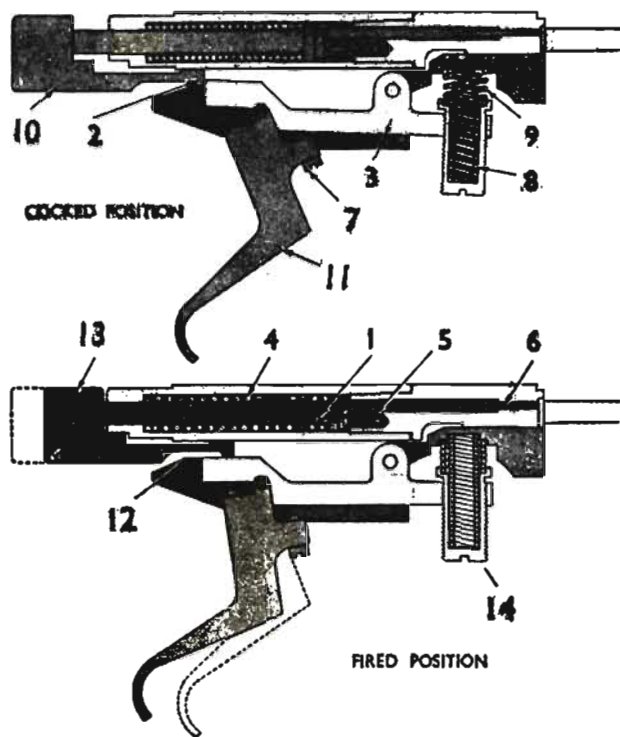

FIG. 28. No. 8 Rifle.

- | | | | |
|---------------------------|---------------------------|-----------------------|-----------------------|
| 1. Striker. | 5. Firing-pin spring. | 9. Outer sear spring. | 12. Sear cradle pads. |
| 2. Bent on cocking-piece. | 6. Firing-pin. | 10. Cocking-piece. | 13. Cocking-piece. |
| 3. Sear. | 7. Trigger setting screw. | 11. Trigger. | 14. Sear spring cup. |
| 4. Striker spring. | 8. Inner sear spring. | | |

Adjustment for trigger pressure: Only the inner spring (8) should be in position for single pressure; and the weight of pull-off is adjusted by screwing, or unscrewing, the sear spring cup (14). This alters the tension of the sear spring (8). One quarter turn of the sear spring cup makes a difference of $2\frac{1}{2}$ ozs. to the weight of pull-off. For the Service double pull-off both sear springs (8 and 9) must be assembled. The sear spring cup should be screwed fully down into the sear, and little subsequent adjustment will be necessary. Screwing up the sear spring cup will increase the tension of both springs, and will govern the weight of both first and second pressures. The length of the trigger pressures can be adjusted by screwing the trigger setting screw (7) in or out.

Furniture. The stock fore-end was slightly wider than that of the No. 4 Rifle in order to provide the firer with a better hand grip, and a pistol-grip was embodied in the butt. Three sling-swivels were fitted, including a combination swivel and front trigger-guard screw; this swivel was to accommodate a sling for target shooting.

Sights. The sights issued with the rifle were similar to those on the No. 4 Rifle, except that the graduations on the backsight leaf were for the 25, 50 and 100-yd. ranges. The leaf also had an additional harmonization position for landscape target practice; this was marked with the letter "H". The standardized foresight dovetail ensured easy replacement of service foresights with commercial match patterns. Commercial sights for match shooting have been

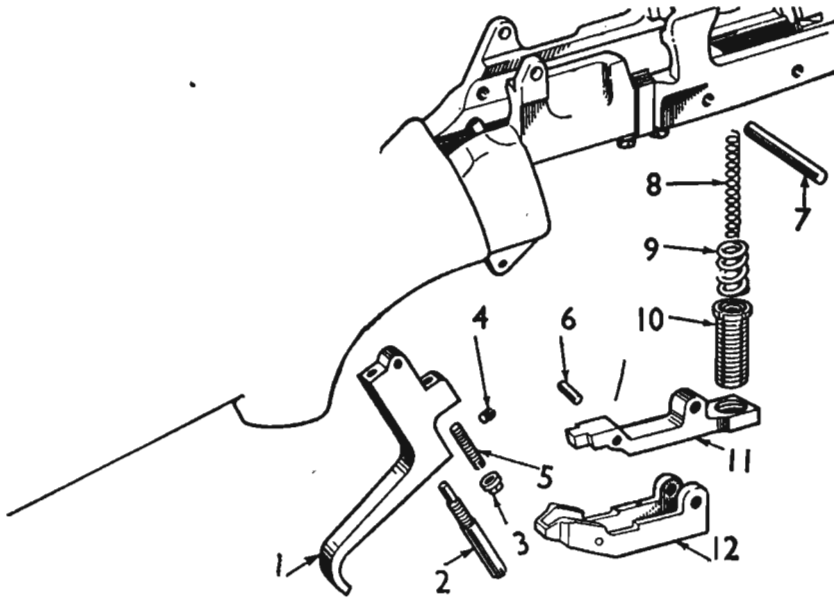

FIG. 29. No. 8 Rifle: Trigger Group.

- | | |
|----------------------------|-----------------------|
| 1. Trigger. | 7. Platform pin. |
| 2. Pull-off setting screw. | 8. Inner sear spring. |
| 3. Trigger setting nut. | 9. Outer sear spring. |
| 4. Pull-off locking screw. | 10. Sear spring cup. |
| 5. Trigger setting screw. | 11. Sear. |
| 6. Trigger pin. | 12. Sear cradle. |

designed which can be readily fitted to the rifle. (Figs. 30 and 31.) *Bolt.* The bolt differed from that of the No. 4 Rifle in that to cock the action it was only necessary to raise and lower the bolt lever, the bolt being drawn to the rear to load or unload. The rear end of the bolt housed a single cocking cam. When in the withdrawn position the cocking-piece was held to the rear against the rear end of the bolt. The striker was shorter than that of the No. 4 Rifle. An independent firing-pin was housed in the bolt-head and was offset radially to strike the cartridge rim. (Fig. 32.)

Stocking-up. The stocking-up was similar to that of the No. 4 Rifle, with good bearings maintained around the body seating, the re-

inforce, and at the muzzle. Additional to these was a bearing at about the middle of the barrel. After much trial shooting it was

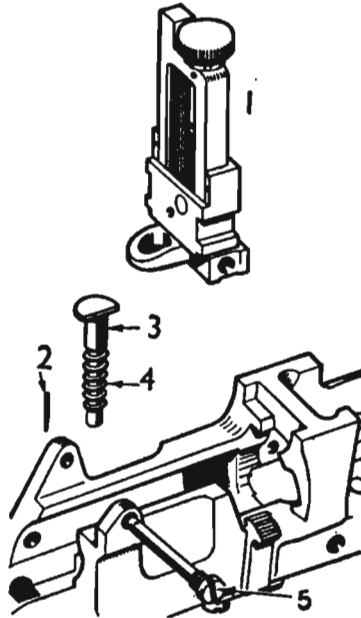

FIG. 30. *No. 8 Rifle: Backsight.*

- | | |
|----------------------------|--------------------|
| 1. Backsight. | 4. Plunger spring. |
| 2. Axis pin retaining pin. | 5. Axis pin. |
| 3. Plunger. | |

found that the best results were obtained with this method of stocking-up.

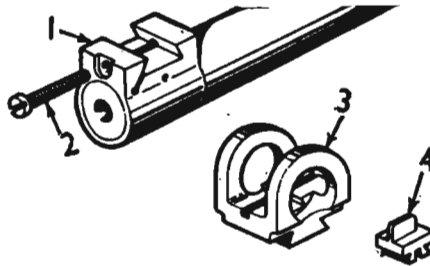

FIG. 31. *No. 8 Rifle: Foresight.*

- | | |
|------------------------------|--------------------------|
| 1. Foresight block. | 3. Foresight protectors. |
| 2. Foresight clamping screw. | 4. Foresight blade. |

Safety. The safety devices were similar to those on the Service weapon with the following differences:

- (a) The safety-catch engaged in a hole in the bolt, instead of in a cam slot. The rear safety recess on the cocking-piece was

semi-circular and did not cause the cocking-piece to be withdrawn when the safety-catch was applied with the cocking-piece in the forward position. (Fig. 33.)

Cartridge platform and ejector. There was no magazine, a cartridge platform being situated immediately in rear of the chamber. The ejector was integral with the cartridge platform. (See Figs. 28, 29, 30, 31, 32, 33 for full details.)

The No. 8 Rifle was manufactured at the B.S.A. Factory at Shirley and at the Royal Ordnance Factory at Fazakerley. Owing to a very unusual error in the issue of serial numbers, numbers 12,001 to 15,187 were issued to both factories, resulting in a duplication of numbers for over 3,000 No. 8 Rifles. The place of manufacture can be traced by factory identification marks on socket or

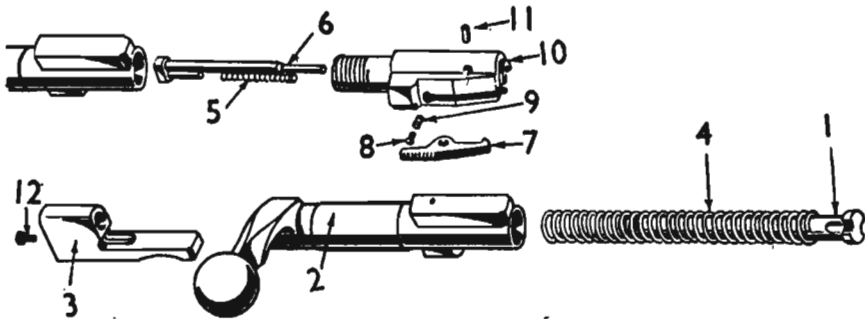

FIG. 32. No. 8 Rifle: Bolt.

- | | |
|-----------------------|-----------------------|
| 1. Striker. | 7. Extractor. |
| 2. Bolt. | 8. Extractor plunger. |
| 3. Cocking-piece. | 9. Extractor spring. |
| 4. Mainspring. | 10. Bolt head. |
| 5. Firing-pin spring. | 11. Extractor pin. |
| 6. Firing-pin. | 12. Striker screw. |

body. The No. 8 Rifle has undoubtedly given valuable service and has been largely responsible for raising the standard of .22 shooting in the British Army, and increasing enthusiasm for competitive target shooting. It is considered by many target shooting enthusiasts that had the longer barrelled No. 8 been chosen, Army marksmen would have been better able to compete on level terms with civilian competitors.

An earlier development of the No. 4 Rifle to take the .22-in. rimfire cartridge had taken place in Canada, and resulted in the introduction of the No. 7 RIFLE in the Canadian Army. It was evolved during the war and over 5,000 had been manufactured at Long Branch by the end of 1945. After the war the Royal Air Force, like the British Army, were in need of a new .22-in. rifle, and decided to adopt the No. 7 Rifle. An order was placed with the B.S.A. Company, who manufactured about 2,500. In appearance and handling, the No. 7 was similar to the No. 4 Service

weapon, the principal difference between the two rifles being the barrel; that of the No. 7 being rifled and chambered to accommodate the .22-in. rimfire cartridge. A small magazine holding five .22-in. cartridges was housed in the Service rifle magazine; the rounds being fed into the chamber in the same manner as with the Service arm.

The latest development with the Lee-Enfield is on account of a requirement for the British Royal Navy. A quantity of No. 4 Rifles are being converted to fire the .22-in. rimfire cartridge by Parker-Hale Ltd. of Birmingham. The converted weapon becomes the No. 9 RIFLE, and the conversion consists of fitting tubes, rifled for the .22-in. cartridge, into the existing barrels, which are bored out to receive the tubes. Chambering, rimming and head-spacing are carried out after the tubes have been fitted in the barrels. Unlike the No. 7, this rifle is not being adapted for magazine feed. The

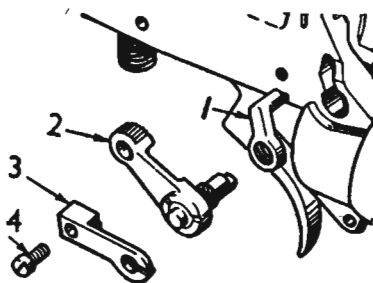

FIG. 33. *No. 8 Rifle: Safety Catch and Locking Bolt.*

1. Safety catch.
2. Locking bolt.

3. Locking bolt spring.
4. Locking bolt screw.

Service Mark I backsight embodies additional zero and 25 yards range marks. In appearance and handling the rifle is similar to the Service arm. In making the conversion, Parker-Hale are repeating history as, during World War I, they converted some 50,000 Service rifles to fire the .22 cartridge. S.M.L.E.s converted in this manner became the Pattern 1914 .22-in. Short Rifle and C.L.M.L.E.s became the .22-in. Pattern 1914 Long Rifle, as already described on page 200. The process which has been developed and carried out by this firm for many years is known as "Parkerifling", and is much favoured by target shooting enthusiasts on account of the high standard of accuracy of "Parkerifled" barrels. The No. 9 Rifle may well be the last of the long line of British Service Lee-Enfields.

APPENDIX "A"

RIFLES AND CARBINES IN

	ARM			
	Weight		Length	
	With	Without	With	Without
	Bayonet or S	word bayonet	ft. in.	ft. in.
MARTINI-HENRY				
CARBINE, ARTILLERY	9 4½	7 10½	5 3½	3 1½
" " Mark II	9 6	8 9	5 0 ⁷ / ₁₆	3 1 ¹ / ₈
" " Mark III	9 2½	7 7	5 0 ⁷ / ₁₆	3 1½
CAVALRY	—	7 10½	—	3 1½
MARTINI-METFORD				
CARBINE, ARTILLERY, Mark I	8 11½	7 12½	4 1½	3 1½
" CAVALRY, Mark I		8 1½		3 1½
" " Mark II		8 4		3 1½
" " Mark III		6 11		3 1½
SNIDER				
CARBINES, ARTILLERY				
(Iron Barrels) Marks II* and III	9 3	7 7	5 3	3 4½
(Steel " " " " " " " " " " "				
SNIDER-LANCASTER O.B... .. .				
MARTINI-HENRY				
RIFLE Mark II (long butt)	9 10	8 10½	5 11½	4 1½
" Mark III " " " "	10 0½	9 1	5 11½	4 1½
(Fitted with short butts Marks II and III were about 2 oz. lighter).				
RIFLE, Mark IV (long butt)	10 11	9 2	5 7	4 1½
" " (short butt)	10 9	9 0	5 6½	4 1
MARTINI-METFORD				
RIFLE, Mark I (long butt)	10 6	9 6½	5 1½	4 1½
" " (short butt)	10 4	9 4½	5 1 ⁷ / ₈	4 1 ³ / ₈
" " II (long butt)	11 6½	9 14	5 7	4 1½
" " (short butt)	11 4½	9 12	5 5	4 1
LEE-METFORD				
MAGAZINE RIFLE, MARK I	10 7½	9 8	5 1½	4 1½
" " " I*.. .. .	10 7½	9 8	5 1½	4 1½
" " " II.. .. .	10 7½	9 8	5 1½	4 1½

THE BRITISH SERVICE 1893

BARREL								REMARKS	
Dimensions		Rifling Grooves							
Length	Diam. of Bore	Number of Grooves	Depth		Type	Twist	Sighting Maximum Range		
			Muzzle	Breech					
ft.	in.	in.	in.	in.			yd.		
1	9 $\frac{1}{8}$.45	7	.007	.009	Henry's	1 in 22	1,180	For Royal Horse, Field, Garrison and Militia Artillery, except Irish Militia Artillery; also for Army Service Corps, Ordnance Store Corps and Field Park Engineers.
1	9 $\frac{1}{8}$	"	"	"	"	"	"	"	
1	9 $\frac{1}{8}$	"	"	"	"	"	"	"	
1	9 $\frac{1}{8}$	"	"	"	"	"	"	"	For all Cavalry Regiments.
1	9 $\frac{1}{8}$.303	"	.004	.004	Metford	1 in 10 Left hand	1,400	
1	9 $\frac{1}{8}$	"	"	"	"	"	"	"	
1	9 $\frac{1}{8}$	"	"	"	"	"	"	"	
1	9	"	"	"	"	"	"	2,000	
2	0	.577	5	.005	.011	Enfield	1 in 48	600	For Artillery Volunteers and Irish Militia Artillery.
2	9 $\frac{1}{16}$.45	7	.007	.009	Henry's	1 in 22	1,450	For Royal Navy, Royal Engineers, Regular Infantry, Marine Artillery, Coastguards, Royal Naval Reserve, Rifle and Engineer Militia and Volunteers, Rifle Regiments, Sergeants of the Line, Rifle Militia, Volunteers and Royal Marines had sword-bayonets. R.N., Coastguard and R.N.R. either sword-bayonets Pattern '87 or M.-H. Rifle, Naval (with cutlass guards), Rank and file of Royal Marines, Line Regiments and Rifle Militia and Volunteers had ordinary bayonets.
2	9 $\frac{1}{16}$	"	"	"	"	"	"	"	
2	9 $\frac{1}{16}$	"	"	"	"	"	"	"	
2	9 $\frac{1}{16}$	"	"	"	"	"	"	"	
2	9 $\frac{1}{16}$	"	"	"	"	"	"	"	
2	9 $\frac{1}{16}$	"	"	"	"	"	"	"	
2	9 $\frac{1}{16}$.303	"	.004	.004	Metford	1 in 10 Left hand	1,900	Only Pattern Arms made.
2	9 $\frac{1}{16}$	"	"	"	"	"	"	"	
2	9 $\frac{1}{16}$	"	"	"	"	"	"	"	
2	9 $\frac{1}{16}$	"	"	"	"	"	"	"	
2	6 $\frac{3}{16}$	"	"	"	"	"	"	3,500	
2	6 $\frac{3}{16}$	"	"	"	"	"	"	2,900	
2	6 $\frac{3}{16}$	"	"	"	"	"	"	2,800	

	ARM			
	Weight		Length	
	With Bayonet	Without Bayonet or S	With word-bayonet	Without net
	lb. oz.	lb. oz.	ft. in.	ft. in.
CARBINES				
MAGAZINE, LEE-ENFIELD, Cavalry, Mark I	—	7 7	—	3 3 $\frac{11}{16}$
" LEE-METFORD, " I*	—	7 7	—	3 3 $\frac{11}{16}$
" LEE-METFORD, " I	—	7 7	—	3 3 $\frac{11}{16}$
MARTINI-ENFIELD, Artillery, Marks I, I*, II, II* and III	8 4	7 4 $\frac{1}{2}$	4 1 $\frac{7}{16}$	3 1 $\frac{1}{16}$
" Cavalry, Marks I, I* and II.. ..	—	6 11	—	3 1 $\frac{1}{16}$
MARTINI-METFORD, Artillery, Mark II ..	8 0 $\frac{1}{2}$	7 1	4 1 $\frac{11}{16}$	3 1 $\frac{5}{16}$
" " " Mark III ..	8 2 $\frac{1}{2}$	7 3	4 1 $\frac{11}{16}$	3 1 $\frac{11}{16}$
" " Cavalry, Mark I* ..	—	8 1 $\frac{1}{2}$	—	3 1 $\frac{1}{16}$
" " " Mark II* ..	—	8 4	—	3 1 $\frac{1}{16}$
" " " Mark III ..	—	6 11	—	3 1 $\frac{1}{16}$
MARTINI-HENRY, Artillery, Mark I.. ..	9 4 $\frac{1}{2}$	7 10 $\frac{1}{2}$	5 3 $\frac{1}{16}$	3 1 $\frac{11}{16}$
" " " Mark II ..	9 6	8 9	5 0 $\frac{7}{16}$	3 1 $\frac{11}{16}$
" " " Mark III ..	9 2 $\frac{1}{2}$	7 7	5 0 $\frac{1}{16}$	3 1 $\frac{1}{16}$
" " Cavalry — ..	—	7 10 $\frac{1}{2}$	—	3 1 $\frac{11}{16}$
RIFLES				
MAGAZINE, LEE-ENFIELD, Marks I and I* ..	10 3 $\frac{1}{2}$	9 4	5 1 $\frac{7}{16}$	4 1 $\frac{1}{2}$
" LEE-METFORD, Mark I* ..	10 7 $\frac{1}{2}$	9 8	5 1 $\frac{1}{2}$	4 1 $\frac{1}{2}$
" " Mark II ..	10 7 $\frac{1}{2}$	9 8	5 1 $\frac{1}{2}$	4 1 $\frac{1}{2}$
" " Mark II* ..	10 3 $\frac{1}{2}$	9 4	5 1 $\frac{7}{16}$	4 1 $\frac{1}{2}$
MARTINI-ENFIELD, Marks I and II ..	9 6	8 5	5 8 $\frac{9}{16}$	3 10 $\frac{1}{2}$
MARTINI-HENRY, Mark II (long butt) ..	9 10	8 10 $\frac{1}{2}$	5 11 $\frac{1}{2}$	4 1 $\frac{1}{2}$
" " " (short butt) ..	10 4	8 8	5 11	4 1
" " Mark III (long butt) ..	10 9	9 1	5 11 $\frac{1}{2}$	4 1 $\frac{1}{2}$
" " " (short butt) ..	10 12	8 13 $\frac{1}{2}$	5 11	4 1
" " Mark IV (long butt) ..	10 10	9 2	5 7	4 1 $\frac{1}{2}$
" " " (short butt) ..	10 8	9 0	5 6 $\frac{1}{2}$	4 1

SERVICE AT THE TIME OF THE BOER WAR

BARREL								REMARKS	
Dimensions		Rifling Grooves							
Length	Diam. of Bore	Number of Grooves	Depth		Type	Twist	Sighting Maximum Range		
			Muzzle	Breach					
ft. in.	in.		in.	in.			yd.		
1	8 $\frac{1}{2}$.303	5	.005	.005	Enfield	1 in 10 Left hand	2,000	
1	8 $\frac{1}{2}$	"	"	"	"	"	"	"	
1	8 $\frac{1}{2}$	"	7	.004	.004	Metford	"	"	
1	9	"	5	.005	.005	Enfield	"	"	Marks I and I* converted from M.-H. Rifle, Mark III. Marks II and II* from M.-H. Artillery Carbines Mark I and III. Artillery Carbine Mark III and Cavalry Carbines Marks I*, II* and III were converted from M.-H. Rifle Mark II.
1	9	"	"	"	"	"	"	"	
1	9	"	7	.004	.004	Metford	"	"	
1	9	"	"	"	"	"	"	"	
1	9 $\frac{1}{8}$	"	"	"	"	"	"	1,440	
1	9 $\frac{1}{8}$	"	"	"	"	"	"	"	
1	9	"	"	"	"	"	"	2,000	
1	9 $\frac{1}{8}$.45	"	.007	.009	Henrys	1 in 22	1,180	
1	9 $\frac{1}{8}$.45	"	"	"	"	"	"	
1	9 $\frac{1}{8}$.45	"	"	"	"	"	"	
2	6 $\frac{1}{16}$.303	5	.005	.005	Enfield	1 in 10	2,800	
2	6 $\frac{1}{16}$	"	"	"	"	"	"	"	
2	6 $\frac{1}{16}$	"	7	.004	.004	Metford	"	2,900	
2	6 $\frac{1}{16}$	"	"	"	"	"	"	"	
2	6 $\frac{1}{16}$	"	5	.005	.005	Enfield	"	1,800	M.-H. Rifles, Marks II and III.
2	9 $\frac{1}{16}$.45	7	.007	.009	Henrys	1 in 22	1,450	
2	9 $\frac{1}{16}$	"	"	"	"	"	"	"	
2	9 $\frac{1}{16}$	"	"	"	"	"	"	"	
2	9 $\frac{1}{16}$	"	"	"	"	"	"	"	
2	9 $\frac{1}{16}$	"	"	"	"	"	"	"	
2	9 $\frac{1}{16}$	"	"	"	"	"	"	"	

APPENDIX "C"

RIFLES AND CARBINES IN THE

	ARM			
	Weight		Length	
	With	Without	With	Without
	lb. oz.	lb. oz.	ft. in.	ft. in.
CARBINES				
MAGAZINE LEE-ENFIELD, Cavalry, Mark I and Mark I*	—	7 7	—	3 3 $\frac{5}{8}$
MARTINI-ENFIELD, Artillery, Marks I, I*, II, II* and III, and Cavalry Carbines Marks I and I*	Details as shown in Appendix B			
MARTINI-METFORD, Artillery, Marks II and III, and Cavalry, Marks I*, II* and III				
MARTINI-HENRY, Artillery, Marks I, II and III, and Cavalry Carbine.				
RIFLES				
SHORT MAGAZINE LEE-ENFIELD:—				
Mark I	9 3	8 2 $\frac{1}{2}$	† 4 8 $\frac{11}{16}$	3 8 $\frac{9}{16}$
Mark I*	9 7 $\frac{1}{2}$	8 7	† 4 8 $\frac{11}{16}$	3 8 $\frac{9}{16}$
† Mark I**	9 3	8 2 $\frac{1}{2}$	† 4 8 $\frac{11}{16}$	3 8 $\frac{9}{16}$
Converted Mark II	9 3	8 2 $\frac{1}{2}$	† 4 8 $\frac{11}{16}$	3 8 $\frac{9}{16}$
Converted Mark II*	9 7 $\frac{1}{2}$	8 7	† 4 8 $\frac{11}{16}$	3 8 $\frac{9}{16}$
† Converted Mark II**	9 3	8 2 $\frac{1}{2}$	† 4 8 $\frac{11}{16}$	3 8 $\frac{9}{16}$
† Converted Mark II***	9 7 $\frac{1}{2}$	8 7	† 4 8 $\frac{11}{16}$	3 8 $\frac{9}{16}$
Mark III	9 11	8 10 $\frac{1}{2}$	† 4 8 $\frac{11}{16}$	3 8 $\frac{9}{16}$
Converted Mark IV	9 15	8 14 $\frac{1}{2}$	† 4 8 $\frac{11}{16}$	3 8 $\frac{9}{16}$
C-L. MAGAZINE LEE-ENFIELD, Mark I* ..	10 4 $\frac{1}{2}$	9 5	5 1 $\frac{7}{16}$	4 1 $\frac{1}{2}$
MAGAZINE LEE-METFORD, Marks I* and II	10 7 $\frac{1}{2}$	9 8	5 1 $\frac{1}{2}$	4 1 $\frac{1}{2}$
" " Mark II* ..	10 3 $\frac{1}{2}$	9 4	5 1 $\frac{7}{16}$	4 1 $\frac{1}{2}$
MAGAZINE LEE-ENFIELD, Marks I and I* ..	10 3 $\frac{1}{2}$	9 4	5 1 $\frac{7}{16}$	4 1 $\frac{1}{2}$
MARTINI-ENFIELD, Marks I, I*, II and II*	Details as shown in Appendix B			
MARTINI-HENRY, Marks II, III and IV (long and short butts)	Details as shown in Appendix B			

† Naval Service only.

‡ Length with Patt. 1903 Sword-bayonet. With Patt. 1907 Sword-bayonet, 5 in. longer.

BRITISH SERVICE IN 1910

BARREL								REMARKS	
Dimensions		Rifling Grooves							
Length	Diam. of Bore	Number of Grooves	Depth		Type	Twist	Sighting Maximum Range		
			Muzzle	Breech					
ft. in.	in.		in.	in.			yd.		
1	8 $\frac{1}{2}$.303	5	.005	.005	Enfield	1 in 10	2,000	
2	1 $\frac{3}{16}$.303	5	.007	.0055	Enfield	1 in 10	2,800	
2	1 $\frac{1}{16}$	"	"	"	"	"	"	"	Converted from: S.M.L.E., Mark I. S.M.L.E. Marks I and I* and M.L.M. Marks II and II*. S.M.L.E. Converted Mark II. S.M.L.E. Converted Mark II*.
2	1 $\frac{1}{16}$	"	"	"	"	"	"	"	
2	1 $\frac{1}{16}$	"	"	"	"	"	"	"	
2	1 $\frac{1}{16}$	"	"	"	"	"	"	"	
2	1 $\frac{1}{16}$	"	"	"	"	"	"	"	
2	1 $\frac{1}{16}$	"	"	"	"	"	"	"	
2	1 $\frac{1}{16}$	"	"	"	"	"	"	"	
2	1 $\frac{1}{16}$	"	"	"	"	"	"	"	
2	6 $\frac{3}{16}$	"	"	.005	.005	"	"	"	
2	6 $\frac{3}{16}$	"	7	.004	.004	Metford	"	"	
2	6 $\frac{3}{16}$	"	"	"	"	"	"	"	
2	6 $\frac{3}{16}$	"	5	.005	.005	Enfield	"	"	
for Marks I and II									M.L.-E. Marks I and I* and M.L.M. Marks II and II*. M.L.E., Marks I and I* and M.L.M., Mark II*.

APPENDIX "D"

RIFLE AND CARBINE CARTRIDGES
AT THE TIME OF

	CHARGE	
	Description of Powder	Weight, grains
.303 Powder Mark II.. .. .	Special Pellet	71.5
.303 Cordite ,, I	Cordite, Size 3 $\frac{1}{4}$	30 $\frac{1}{2}$
,, ,, ,, II	,,	,,
,, ,, ,, V	,,	,,
,, Short Range Practice Mark II.. .. .	Cordite tape	12
Martini-Henry Carbine, Rolled Case*, Mark III	R.F.G.†	0
,, ,, ,, Solid Case, Mark I	,,	65
,, ,, Rifle, Rolled Case, Mark III	,,	85
,, ,, ,, Solid case, Mark II†.. .. .	,,	85
Snider, Mark IX (Rifle or Carbine)	R.F.G.	70

* Had three longitudinal cuts .5 inches in length, made through the paper (on the side of the bullet) after being lubricated, to facilitate bullet being freed from paper on firing.

† The case had a paper lining, and the paper round the bullet only extended about two-thirds up the bullet.

‡ The charge was of such weight as would give the requisite velocity within specified pressures, and was about 30 grains.

**IN THE BRITISH ARMY
THE BOER WAR**

BULLET			CARTRIDGE			REMARKS
Diam.	Length	Weight	Length	Weight of Bundle	No. in Bundle	
in. ·311	in. 1·236	grams 215	in. 3·05	lb. oz. - 10½	10	Mark I had been converted to Blank. Mark II differs from Mark I in having a solid anvil and a larger cap.
·311	1·25	215	"	- 9¾	"	
"	"	"	"	"	"	
"	"	"	"	"	"	
"	1·07	188	"	- 8¼	"	Mark I was obsolete.
·45	1·125	410	2·98	1 0	"	For Home Service.
·45	1·102	"	"	1 2½	"	
"	1·27	480	3·15	1 1¾	"	For Home Service.
"	"	"	"	1 4½	"	
·573	1·04	"	2·445	1 0¾	"	For Royal Irish Constabulary. It was introduced in August 1871.

APPENDIX "E"

EXPLANATION OF SYMBOLS

- Examiner's stamp. The serial number below the "E" identifies the examiner responsible for passing the work. The letter "E" may be in various positions, i.e. in normal position or reverse, on its back (as shown) or on its arms, and above or below the serial number according to issue of stamp.
2. Examiner's stamp (Enfield pattern). Indicating stores passed and accepted for Government service. Slight variations in arrow design are in use.
 3. "E" stamp. Indicating anything apertaining in particular to Enfield, e.g. Enfield form of rifling. Examination at Enfield.
 4. National Rifle Association stamp. Arms supplied to N.R.A.
 5. Percentage stamp. Where 10% of batch stores were examined and stamped with Examiner's View-mark, the remainder were stamped with the Percentage mark, if the batch percentage was accepted.
 6. Sale mark. Indicating stores for sale to general public.
 7. "N" stamp. Indicating arms and components accepted on behalf of Royal Navy.
 8. Pattern stamp. Indicating .22 in. calibre arms of approved War Office Pattern.
 9. Material stamp. Used to identify batches of steel. Variations in design of crown were used.
 10. Sale mark. Indicating sale to general public.
 11. Classification stamp. Denoting arms to be used only for drill purposes.
 12. New Zealand stamp. Stores accepted for the New Zealand Service.
 13. Badge stamp. Used on small arms to denote Crown Property, and reign during which the weapons were manufactured.
 14. Sale mark. Serviceable small arms, such as rifles for competition shooting, sold to the public.
 15. Morris Tube stamp. Indicating arms with barrels fitted with Morris Tubes, i.e. centre-fire .22 in. calibre.
 16. Canadian Service Stamp. Stores accepted for the Canadian Service.
 17. Proof stamp. Used on all assembled arms which have passed proof.
 18. Defect stamp. Used on barrels to denote rust pitting, and on components with slight defect but still serviceable. Sometimes used, in conjunction with Roman numerals, to indicate the "Mark" of an arm.
 19. Aiming Tube mark. Indicating that the weapon was fitted with an Aiming Tube.
 20. Australian Services stamp. Stores accepted for the Australian Services.
 21. Proof stamp. Used on Breech blocks, Breech bolts, and bolt-heads which have passed the proof test.
 22. Indicating arms repaired at Birmingham. In the past similar marks were allotted to private firms.
 23. Part worn mark. Stamped on barrel, indicated barrel part-worn but serviceable.
 24. Early Australian Service stamp. Superseded by No. 20.
 25. Property stamp. Denoting War Office property.
 26. Emergency classification stamp. Denoting components stored for emergency purposes only; also for Rifle and M.G. barrels with oversize bores.
 27. High velocity stamp. Indicating a high velocity sight on the barrel.
 28. Iraq stamp. Accepted for the Iraq Army.
 29. Date stamp. Denoting the year of acceptance.
 30. Emergency classification stamp. Denoting weapons to be used for emergency purposes only.
 31. "Ring Eight" stamp. Indicating barrels suitable for Mark 8 ammunition.
 32. South African stamp. Accepted for the Union of South Africa.
 33. Cancellation mark. Used in cancelling serial numbers.
 34. Classification stamp. (Various sizes) Indicating weapon components suitable for drill purposes only.
 35. Unproofed stamp. Indicating that arm or component was issued to the Service unproofed.
 36. Irish Free State stamp. Stores accepted for the Irish Free State.
 37. Special sale mark. Denoting arms, sold to County Association for Cadets, which were fitted with "safe" barrels.
 38. Special sale mark. Denoting arms, sold to County Association for Cadets, which were fitted with "unsafe" barrels.
 39. Special sale mark. Denoting arms, sold for drill purpose, which were fitted with "unsafe" barrels.
 40. Condemned stamp. Denoting small arms condemned by R.A.O.C. Workshops.

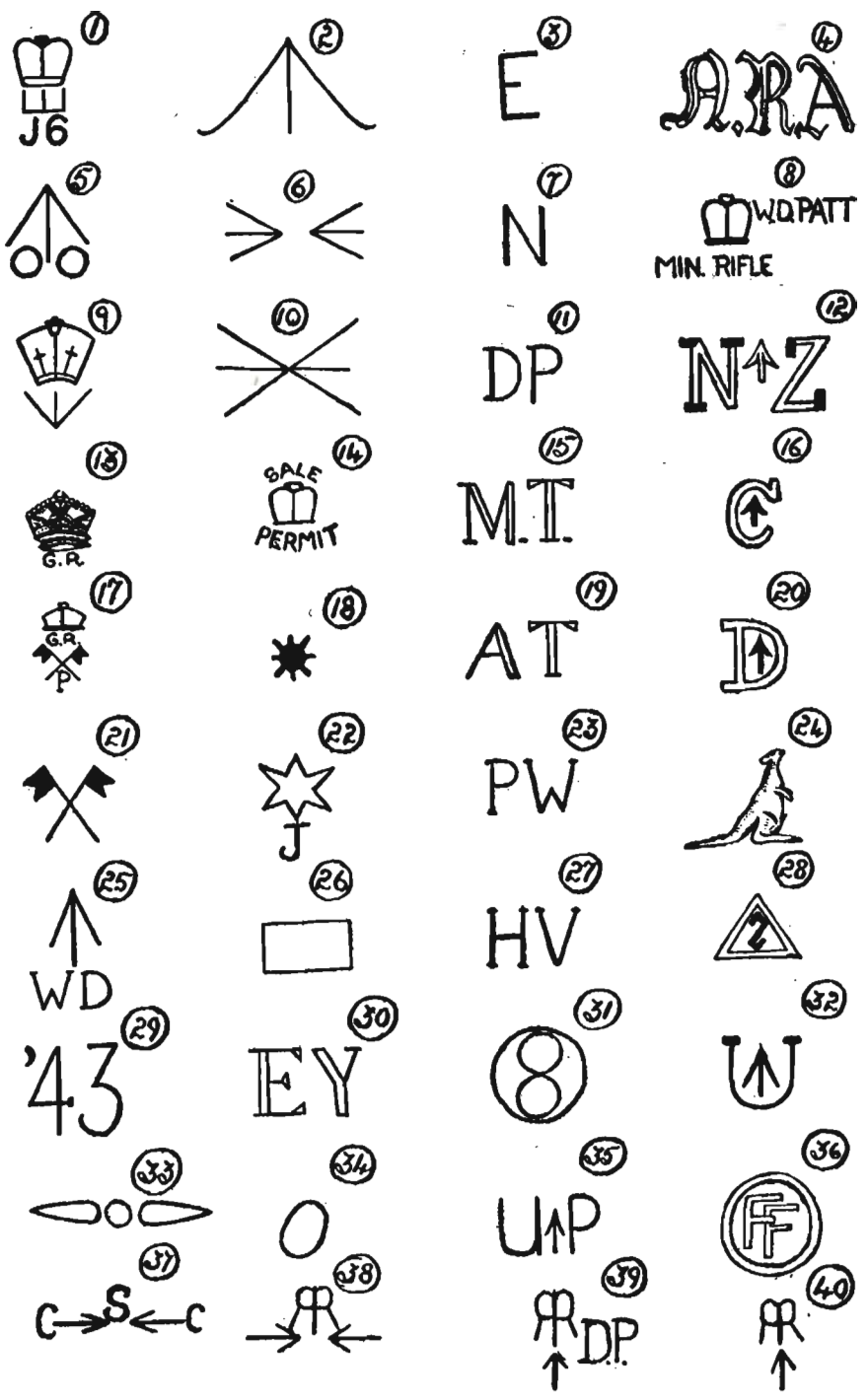

STAMP SYMBOLS USED BY EXAMINERS OF THE CHIEF INSPECTOR OF SMALL ARMS

Any of the majority of them may be found on Lee-Enfield Rifles manufactured before the Second World War. Some are still used by the Inspectorate of Armaments.

APPENDIX "F"

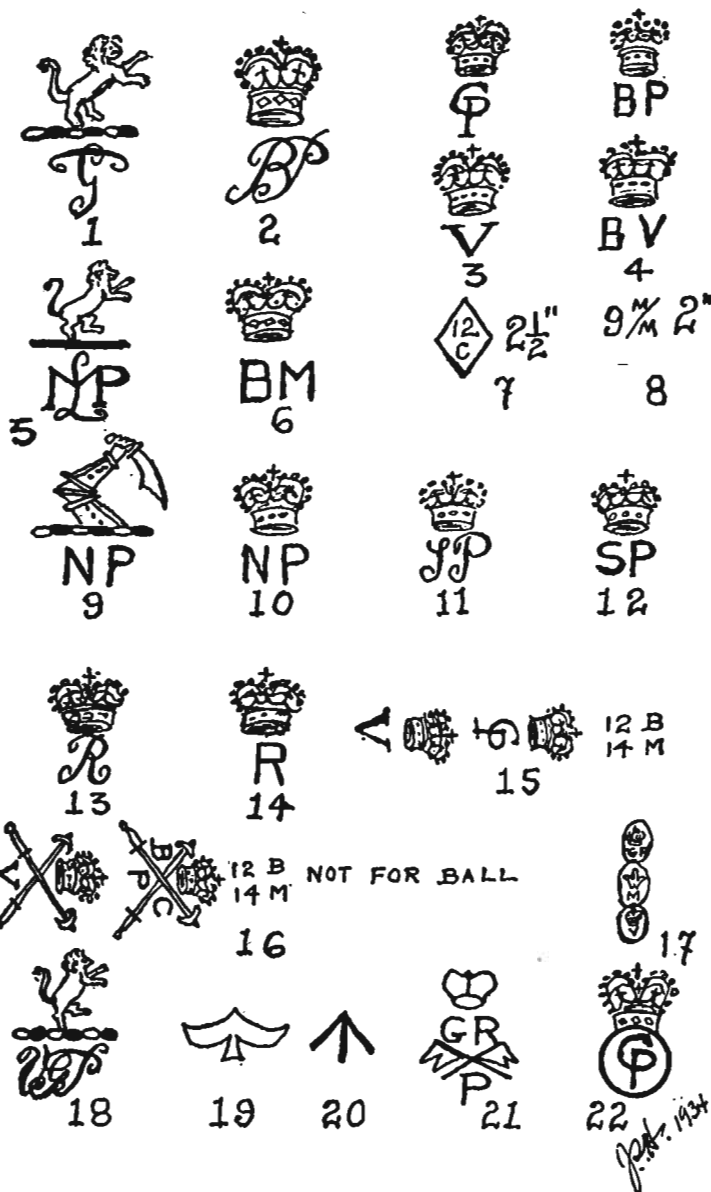

BRITISH PROOF MARKS

1. London Provisional Proof. 2. Birmingham Provisional Proof. 3. London Definitive Proof. 4. Birmingham Definitive Proof. 5. London Mark for special definitive proof of Rifle barrels, Class 10. 6. Birmingham Mark for special definitive proof of Rifle barrels, Class 10. 7. Chamber mark, breech loading shotguns. (Bore and length of cartridge). 8. Chamber mark, breech loading rifled arms. (Calibre and length of cartridge). 9. Nitro Proof, London. 10. Nitro Proof, Birmingham. 11. Special Proof, London. 12. Special Proof, Birmingham. 13. Re-proved Arms, London. 14. Re-proved Arms, Birmingham. 15. Choke Bore Mark, London, now obsolete. Upper figure, "12 B" shows gage at breech, lower figure, "14 M" shows gage at muzzle. 16. Choke Bore Mark, Birmingham. 17. An old London Mark, now long obsolete. 18. London Mark employed prior to new rules adopted in 1925. 19. The "Broad Arrow", sign of Government ownership. 20. Another form of the Broad Arrow. 21. Military Proof of rifles and automatic pistols. 22. London Definitive Proof for arms of foreign make. Followed by the words "Not English Make". Marks numbers 1, 2, 3, 4, 5, 6, 9, 10, 11 and 12 are treated in a similar way when applied to arms of foreign make after British proof; consequently all these marks may be seen with the letter or letters enclosed in a circle, and followed by "Not English Make".

INDEX

- Abel, Sir Frederick, 29
 Accuracy Testing, 65-7, 170, 176, 177, 194
 (see also Trials)
 Life of Lee-Metford barrels, 37
 No. 5 Rifle barrels, 164, 165
 worn Service Rifle barrels, 77
 Actions, Cei Gas Rifle, 69
 Falling-block, 21
 Lee bolt-action, 24-8
 Lee-Enfield, 43, 44
 Martini-Henry, 20
 .22-in. Rifle (No. 8), 203-6
 P.14 Enfield Rifle, 123, 126
 Snider, 18, 19
 Aiming, by aperture sight, 132, 156
 by barleycorn and notch, 31
 by bead and notch, 80-2
 by light lines, 29
 Aldershot, 59, 125, 126
 American Civil War, 179
 Aperture Sights, see Sights
 Armament Inspection, see Ministry of Supply
 Armstrong, Sir W. G., & Co., 179
 Australia, 188
 Australian Factories, Bathurst, 190; Lithgow, 188, 190, 192, 195; Feeder factories, 192
 Forces, 190, 195, 196
 Lightened Rifles, 195-6
 Rifle Clubs, 194, 196
 Short Magazine Lee-Enfield Rifle, 188-196
 Sniper Rifles, 195
 Weapon production, 188-196
 Austria, 23, 25, 66
- Barrel, Accuracy life of worn Service rifle barrels, 77
 Enfield, 49, 50, 51, 75, 92-4, 113
 First British Army rifled barrel, 17
 with special "lead", 92-6, 104, 105, 114
 Lapping, 93, 94
 Manufacture, 158, 159, 174, 175
 Plug gauges, 77
 Bayonet, Comparison of bayonets, 135-7
 Effect on accuracy, 142-5, 155, 165
 New Pattern, 130, 131, 134
 No. 4 Mark I, 137, 148, 150
 No. 4 Mark II, 148-50, 161
 No. 4 Mark II*, 148-50, 161
 No. 4 Mark III, 151
 No. 5 Mark I, 165
 Mark VI (for No. 1 Rifle), 162
 Return of Sword-bayonet, 182
- Scabbards, 29, 46, 137, 149, 150, 161, 162
 Sword Pattern 1888, 46, 54
 1903, 84, 88, 98
 1907, 110
 Birmingham Small Arms Co., see Factories
 Bisley, 55, 113, 121, 132, 164, 186, 195
 Black powder, 19, 26, 30, 36, 54
 Boers, accurate shooting, 55, 56, 58
 Bolt Mechanism, Lee-Enfield, 43-4
 No. 3 (P.14) Rifle, 123-6
 No. 4 Rifle, 147, 152
 No. 8 Rifle, 204
 Boxer Cartridge, 18, 19
 Colonel, 18
 Breeching-up, 132, 175, 176, 185, 186
 Bren L.M.G., 130, 154, 170, 180, 190, 192, 195, 196
 Bridge-charger-guide, see Loading
 British Air Commission, 154
 British Army and British Service, 17, 18, 49, 55, 56, 59, 67, 77, 84, 86, 90, 107, 113, 119, 121, 122, 125, 128, 164, 169, 171, 179, 180, 182, 183, 197, 198, 200-2
 Artillery units, 48, 49, 58
 Cavalry press for new weapon, 73
 Cavalry units, 56, 57, 58, 79-82, 145
 G.O.C. 1st Army Corps, 82
 G.O.C. South-Eastern District, 82
 G.O.C. in C., Aldershot, 126
 Infantry units, 51, 52, 55, 56, 59, 79-81, 103, 104, 120, 145, 172
 Orders, 27
 Ordnance Stores, 56
 Service Corps, 48
 Staff, 130, 154
 Government, 178, 179, 180, 181
 Purchasing Commission, 154
 Bullets, see Cartridges
 Bullet, Armour-piercing, 129
 Dangerous space, 114
 Effect at extreme range, 59, 60
 Hollow-nosed, 53
 Pointed bullet introduced, 115
 Steel-coated, 124
 Tracer, 129
 with special cannellures, .276 cal., 125
 Pritchett, 17
 Butts Stock, Bantam, 120
 Long and Short first issued, 76
 Loose on service, 76
- Canada, Inspection Board, 152, 154
 Long Branch Factory, 154
 Rifle production, 152, 153, 206
 Cavalry, see British Army

- Carbines, 56, 58, 73, 83, 75
 Lee-Enfield Mark I, 50, 54, 75
 Mark I*, 54,
 Magazine, 54
 Lee-Metford, 35, 50, 51, 75
 Martini-Enfield, 49, 50, 54, 76
 Martini-Henry, 50, 51
 Martini-Metford, 51, 76
 Snider, *see* Appendix A
- Cartridges, Black Powder, 18-21, 29, 30
 Boxer, 18, 21
 Dum-Dum, 52
 First British Smokeless, 30
 Lighter bullets, 114
 Martini-Henry, 21
 Nato 7.62-mm., 177
 Short-range Practice, 48
 Smokeless, 25
 Special for Trials and Tests, 65, 95, 125,
 138-9
 Variables in manufacture, 91, 92
- Cartridge, .303-in. S.A. Ball Magazine,
 Mark I, 29
 Cordite, Mark I, 30
 Cordite, Mark II, 30, 48, 52
 Marks III, IV and V, 53, 116
 Mark VI, 98, 114, 115
 Mark VII, 115-9, 126, 128, 138-40,
 165
 Mark VII*, 116, 165
 .276-in. Experimental, 124-7, 129
 .22-in. C.F. Black powder, 197, 200
 .22-in. R.F., 197, 199
 .22-in. R.F. Aiming-tube, Mark I, 199
 .22-in. C.F. Aiming-tube, Mark I, 199
 .22-in. R.F. No. 1 Smokeless, Mark I,
 200
- Cei Gas Rifle, 68-70
 Cei-Rigotti, Capt., 68
 Chargers, 30, 83, *see also* Loading
 Charlton, Mr., New Zealand, 196
 Chief Inspector of Small Arms, *see* Enfield
 Cleaning, 31, 53, 74
 Cleaning-rod, 28, 29, 31, 34
 Clearing-rod, 34, 54
 Conversions, 20, 48-50, 54, 97, 98, 107,
 110-113, 118, 154, 170, 196, 197-201,
 207
 Cordite, 30, 48, 97, 99, 116
 effect on barrels, 30, 37, 99
 M.D. and T., 99
 M.D.T., 99, 115, 124, 126
 Cordite Cartridges, influence on sighting
 system, 31, 48
 Crimea, 17
 Curreagh, The, Board of Officers, 79, 80
 Cut-off, 28, 34, 35, 44, 81, 86, 90, 98, 103,
 104, 107, 110, 113, 131, 143
- Dantzig, German Army, 23
 Denmark, 66
 Dewar, Sir James, 29
- D.P. Arms, 33
 Dum-Dum, *see* Cartridges
 Dunkirk, 157, 190
- Enfield, Armament Design Establishment,
 196, 202
 Barrels, *see* Barrels
 Muzzle-loading Rifle, 17, 18
 Rst, 176
 Royal Small Arms Factory, 17, 37, 49,
 63, 70, 77, 104, 108, 114, 124, 125,
 142, 145, 154, 157, 161, 164, 170,
 172, 178, 181
 Superintendent, 61, 64, 70-3, 83, 93-4
 Proofmaster, 70
 Chief Inspector of Small Arms, 61, 66,
 67, 97, 108, 116, 173, 180
 Travelling view, 77, 179
 .38-in. Pistol Revolver, 180
 Erosion of barrels by Cordite, 30, 37, 99
 EY Rifle, 120, 121
- Factories, B.S.A., 63, 124, 141, 154, 156,
 159, 170, 206
 Eddystone, Remington and Winchester,
 see U.S.A.
 Lewisham, 178
 Lithgow, *see* Australia
 Long Branch, *see* Canada
 London Small Arms, 178
 Nat. Arms & Ammunition Co., 180
 R.O.F., Fazakerley, 77, 154, 206
 R.O.F., Maltby, 154
 R.S.A.F., Enfield Lock, *see* Enfield
 R.S.A.F., Bagot Street, Birmingham, 180
 R.S.A.F., Sparkbrook, 63, 64, 180
 Superintendent, 64
 Savage Arms Co. and Stevens Arms Co.,
 see U.S.A.
 Tower of London, 178
 Franco-Prussian War, 23
 French development, smokeless propel-
 lants, 25
 Fulton, Major Robin, 187
- Gardner Machine-gun, 179
 Gatling Machine-gun, 179
 German 7.92-mm. Rifle, 161
 Germany, 22, 66, 161, 180
 German Army, 23, 25, 122
 Grenade Discharger, 120, 121, 141
 Guncotton, 30
- Harmonics, 139
 Henry, Alexander, 20
 Henry Barrels, 20, 21, 24, 50
 Holland & Holland, 170
 House of Commons, 179
- Identification Marks, 177, 178, 206,
 Appx. E

- India (and Ishopore), methods of stocking-up, 184
 India, 37, 100
 North-West Frontier, 51, 52, 107
 Inspectorate of Armaments, *see* Ministry of Supply
 Italy, Army, Florence Div., 68
 Cei Gas Rifle, 68-70
Il Messagero, 68
 Method of testing rifles, 66
- Jag, for cleaning rod, 28, 31
 Jamaica, 54
 Jump, 139, 144, 164, 172
- Kellner, Dr., 29
 Kitchener, Lord, 100-4, 188
 Konizsberg, 23
- Lebel Rifle, 25
 Lee, James P., 24
 Lee Bolt Action, 24, 27, 28, 43, 44, 141, 144, 147, 152, 153
 Lee-Enfield Rifle, *see* Rifles
 Manufacturing markings, 178
 Method of manufacture, 173-8
 Lee Improved Rifle, 24
 Lee Magazine, 24, 25, 28
 Lee-Metford Rifle, *see* Rifles
 List of Changes, 27, 75, 89, 117, 119, 152
 Loading Methods, Automatic, early British interest, 68
 Clip, 25
 Charger, 30, 97, 108, 112, 113, 119, 123, 126
 Controlled platform systems, 75
 Early breech-loading, 18, 22, 23
 Gas-operated, 68-70
 Magazine, introduction, 22-7
 Muzzle, 17, 20, 23
- Machine-guns, 116, 130, 154, 170, 179, 180, 190, 195, 196
 Magazine loading, *see* Loading Methods
 Mannlicher Rifle, 25, 93
 Martini, Frederick von, 20
 Martini-Enfield Carbines, *see* Carbines
 Rifles, *see* Rifles
 Martini-Henry Carbines, *see* Carbines
 Rifles, *see* Rifles
 Martini-Metford Carbines, *see* Carbines
 Rifles, *see* Rifles
 Mauser Rifle, 56, 101, 126, 181
 System, 23, 123
 Metallic fouling, *see* Trials
 Metford, Mr., 21
 Metford Rifling, *see* Rifling
 Barrels, 33, 37, 50, 51, 54, 60, 75
 Mineral Jelly, 30, 95
- Ministry of Supply, 152, 159, 179, 187, 202
 Chief Inspector of Small Arms, *see* Enfield
 Experimental Establishment, Pendine, 160, 164
 Inspectorate of Armaments, 179, 184, 185
 of Aircraft Production, 152
 Misfires, striker protrusion, 51
 Mitrailleuse, 68
- Napoleonic Wars, 178
 National Rifle Association, 61, 113, 114, 132, 184, 186, 187, 195
 New Guinea, 195
 New Zealand, 196
 Nitro-cellulose, 116
 Nitro-glycerine, 30, 37, 99, 128
 North-West Frontier Campaigns, 51-3
- Oil bottle, 28, 33, 104
 Rangoon, 54, 95
 Ordnance Board, 124, 160
 Owen-Jones Rifle, 24
- Parker-Hale Ltd. ("Parkerifling"), 207
 Pattern 1914 Rifle, *see* Rifles
 Pavay, P. A., 195
 Pavlichenko, Lieut. Ludmilla, 181
 Physical Training Staff, 135
 Piling arms, 28
 Plastics, 161
 Plumstead Marshes, bullet trial, 125
 Pratt & Whitney Corporation, 188, 190
 Pritchett Bullet, 17
 Proof test, 176, 177
 Protective greases, experiments, 53, 54
 Prussian Army, 22
 Pull-off, "drag" or double pull, 73, 80, 83, 86, 89, 100, 102, 103, 182, 183
 Pullthroughs (Marks I and II) and accessories, 31, 33, 104
- Queen's Prize, 187
 Queensland Defence Force, 58
- Ranges for accuracy acceptance testing, 62, 65, 66, 194
 Rifles, accuracy testing, 65-7, 170, 176, 177
 Austria, France, Germany, Italy, Switzerland and U.S.A., 66
 Enfield Muzzle-Loaders, 17, 20
 Enfield-Martini, 21
 F.N. Automatic, 187, 192
 "Furniture" problems, 160-1, 165, 183
 Manufacture, 176
 German 7.92-mm., 161
 Improved Lee, 24
 Lebel, 25
 Lee-Magazine, 24

- Rifle, Lee-Enfield, 50, 54, 59, 60, 64, 67, 74-6, 83, 93, 97, 98, 100, 102-4, 105, 107, 110, 113, 120, 137, 138, 181, 188, 189, 199
 as "Sporter", 187
 comparison with short Rifle, 84-9
 description, 39-47
 defective sighting in South Africa, 55-8
 sighting rectification, 61-3,
 with special "Leads", 92-6, 114
 Mark I introduced, 39
 Mark I* introduced, 54
 Charger-loading Mark I*, 111, 113, 119, 200, 207
 New pattern for British Army is conceived, 129-31
 Lee-Metford, 31-7, 39, 48, 50-2, 56-60, 63, 75, 76, 83, 97, 98, 107, 110, 113, 181, 197, 198, 199
 Mark I introduced, 31
 Mark I* introduced, 31
 Mark II introduced, 33
 Mark II* introduced, 35
 Charger-Loading Mark II introduced, 111
 Shortened Modified Lee-Enfield, adoption recommended, 83
 Shortened Modified Lee-Enfield, 71-5
 Magazine, Mark I, 26, 49, 50, 98
 Mannlicher, 25, 92
 Martini-Enfield, Mark I, 49, 50, 98
 Mark I*, 49, 50, 98
 Mark II, 49, 50, 98
 Mark II*, 49, 98
 Martini-Enfield, 56, 58, 113
 Martini-Henry, 21, 22, 28, 48, 49, 50, 51, 54, 57, 58, 179, 197
 Martini-Metford, Mark I, 54, 76
 Mark II, 54, 76
 No. 1, 146, 151, 158, 162, 181, 186, 187, 196
 No. 2, Mark IV*, 201
 No. 3 (Pattern 1914 Enfield), 123-8, 130, 144, 148, 186, 187
 (Sniper), 128, 133, 144, 169
 No. 4, Mark I, first made at Enfield, 146
 Introduced, 146
 Description, 146-151
 151, 164, 180, 181, 183, 186, 187
 All-metal model, 159-60
 Lightened design, 164
 Modification and relaxations, 156-63
 Change in nomenclature,
 Breeching-up, 185, 186
 Redesign of pull-off, 182, 183
 Identification and manufacturers' markings, 177-8
 Proof testing, 177
 Mark I (T), 170, 181
 first issues, 172
 Mark I*, 152-4, 195
 How it differs from Mark I, 153
- Rifle, No. 4.—*continued.*
 Mark II, 183
 Mark I/2, 183
 Mark I/3, 183
 Mark I/2 (T), Sniper, 183
 No. 5, Mark I, 164-9, 181, 195
 Mark II, 168
 No. 6 and No. 6 (Australian), 196
 No. 7, .22-in., 154, 206
 No. 8, .22-in., 202-7
 No. 9, .22-in., 207
 Owen-Jones, 24
 S.M.L.E., Mark I, 84-9, 93-8, 100-7, 109, 110, 112
 Introduction and description, 84-9
 Comparative trials with L.E., 104-5
 Accuracy research, 91-6
 Extreme sighting range, 96
 Re-introduced, 89
 With special "leads", 92-6, 114
 Examination of troop trial rifles, 97
 Mark II, introduced, 97
 Mark II, 107, 110-12, 116, 117, 199, 200
 Mark I*, introduced, 106
 Mark I*, 116-118
 Mark I**, introduced, 112
 Mark I**, 119
 Mark II*, introduced, 107
 Mark II*, 116, 199, 200
 Mark II**, introduced, 112
 Mark II**, 119
 Mark II***, introduced, 112
 Mark II***, 118, 119, 201
 Mark III, introduction and description, 109-10
 Mark III, 112, 113, 116, 117, 119, 131-3, 142-6, 188, 198, 200, 201
 Becomes the No. 1 Rifle, 144
 Mark III*, introduction, 120
 Mark III*, 178, 183, 201
 EY, introduced, 120, 121
 Heavy barrel, for target shooting, 186
 Heavy barrel, Australian, 192
 Mark IV, introduction, 110, 111
 Mark IV, 116, 117, 200
 Mark V, 131-3
 Mark VI, 133, 138-40, 140-44
 Becomes the No. 4 Rifle, 144
 All Marks, 111, 120-122, 126
 Proof test, 177
 Snider-Enfield, 18, 20, 179, 181
 .22-in. Aiming Tubes, 197
 Morris, 197
 S.M.L.E. Aiming Tube, Mark I, 197, 198
 R.F. Long Rifle, Mark I, 199
 Mark I*, 199
 Mark II, 199
 Pattern 1914, Long Rifle, 200
 Short Rifle, 199, 201
 Mark I, 200
 No. 2, 200

- Rifle, 22-in. R.F.—*continued*.
- Short Rifle, Mark I, 198, 199
 - Mark I*, 199
 - Mark II, 199
 - Mark III, 199
 - No. 2, 200
 - Mark IV, 201
 - No. 2, Mark IV*, 201
 - No. 7, 22-in., 154, 206, 181
 - No. 8, 22-in., 181, 202-7
 - No. 9, 22-in., 207
 - Rifling, Enfield, 37, 48, 49, 54, 74, 75, 93, 94, 108, 118
 - 276-in., 125
 - 2-groove, 158
 - 3-groove, 17, 158
 - 4-groove, 158
 - 6-groove, 154
 - Drawn-tube method of manufacture, 159, 175
 - 22-in., 198
 - 22-in., 6-groove, tapered, 202
 - Manufacture, 173
 - "Parkerifling," 22-in., 207
 - Roberts, Field-Marshal Lord, V.C., 55, 57
 - Royal Marines, 79, 82
 - Royal Navy and British Naval Service, 17, 22, 29, 79, 86, 87, 98, 112, 118, 119, 179, 207
 - Royal Navy, H.M.S. *Excellent*, 61, 79, 114
 - School of Gunnery, Sheerness, 79, 80
 - Ordnance Depots, 112
 - Russian Sniper, 181
 - School of Musketry, Bisley, 121 (later *see* Small Arms School)
 - Hythe, 73, 75, 91, 124, 125
 - Commandant, 61
 - India, 100, 104
 - Sighting Systems, Mauser Rifle, 56
 - British Service Rifles, 48, 50, 62, 72-5, 84, 85, 111, 112, 117-20, 124-6, 131, 132, 134, 141-3, 195
 - Alterations due to Mark VII cartridge, 116-9
 - Corrective measures on rifles in South African War, 62-6
 - Defective sighting rifles in South African War, 55-8
 - Sights, Backsight, Aperture, 124-7, 131-4, 141-3
 - No. 4 Rifle, 146-7
 - Mark I, 155, 165, 170, 182
 - Mark II, 155, 156
 - Marks III and IV, 156, 157
 - No. 5 Rifle, Mark I, 165, 167
 - Mark II, 167
 - No. 8 Rifle, 204, 205
 - Battle or fixed, 126, 131, 134, 143, 147, 155
 - Leaf and V-notch, 29, 32, 33, 34
 - Special match shooting slide, 33
 - Redesigned for Cordite, 36, 39, 49, 50, 54, 57, 62, 63, 72-5, 80, 85, 101, 103, 106, 109
 - "A" type Experimental, 80, 81, 83
 - "B" type Experimental, 80, 81
 - Leaf and U-notch, 109, 112, 117-9
 - Sights, Foresight, Barleycorn, 31, 32, 49, 50, 54, 57, 62, 63, 83-5, 101, 105, 109, 117
 - Bead, 57, 80-3
 - Blade, 32, 109-12, 117-9, 133, 141, 147
 - No. 4 Rifle, Marks I and I*, 162, 163
 - Marks II and III, 163
 - Square block with vertical cuts, 29
 - Long-range, Dial, 29, 32, 39, 40, 85, 96, 115, 117, 119, 120, 124, 126, 131
 - Windgauge, 57, 81-3, 89, 100, 101, 106, 109, 110, 118-20, 125
 - War-time modifications, 155, 156, 194
 - Slazengers (Aust.) Ltd., 192
 - Small Arms Inspection Dept. and Testing Section, 77, 161, 172, 173, 176, 179-81
 - Small Arms School, Bisley, 164
 - Hythe, 108, 114, 133, 134, 142, 145, 156 (earlier *see* School of Musketry)
 - Smeaton, 178
 - Smokeless Powder, 21, 25, 29-31
 - Snider-Enfield Rifle, 18-20, 179, 181
 - Snider, Jacob, 18
 - Sniper Rifles, *see* Rifles
 - Sniper Telescope Sights, *see* Telescopes
 - Society of Miniature Rifle Clubs (N.S.R.A.), 201, 202
 - South Africa, 55-8, 61, 63, 69, 97, 108, 180, 181, 188
 - South Australia, 49
 - Somaliland Field Forces, 90, 107
 - Stocking-up, No. 4 Rifle, 150, 151, 183-5
 - No. 5 Rifle, 165-8
 - No. 8 Rifle, 204, 205
 - Short Magazine Lee-Enfield Rifle, 89
 - War-time relaxations, 161, 183
 - Sudan, 52
 - Target Shooting, 132, 184, 186, 187, 195, 197, 201
 - Telescope Sights, Aldis Offset, 128, 169, 170
 - No. 32, Mark I, 170, 171
 - No. 32, Mark II, 171
 - No. 32, Mark III, 171
 - Pattern 1918, 128, 169, 170, 195
 - Telescopic Layer, 171
 - Testing effect of "bullet lodged in barrel", 116
 - of "oiled bullets", 94-6
 - Efficiency of S.M.L.E. Rifle in sandy conditions, 91
 - Tippens, L. R., 121
 - "Travelling View", *see* Enfield R.S.A. Factory

- Trials, Bent barrels, 159
 Captured German rifle, 161
 Cei Gas Rifle, 70
 "Compensation" No. 1 Mark VI Rifle, 137-40
 Comparative Trials, Long and Short Rifles, 104, 105
 Effect of bayonet on accuracy, 142-4
 India 1894, 37
 Long Range (Aldershot), 59, 60
 New charger-loading system, 108
 No. 4 Rifle (stocking-up), 184
 No. 4 Rifle, Mark I (T), angle of "jump", 172
 No. 5 Rifle, wandering "zero", 168, 169
 No. 5 Rifle, development, 164
 Shortened Enfield Rifles, Hythe, 75
 Sighting stability, 64
 Static force, 94
 To ascertain cause of metallic fouling (.276-in. cartridge), 124, 125
 Service comparative trials, 145
 with lighter bullet, 114
 with new S.M.L.E. Rifles at Aldershot, 109
 with 20-round magazines, 121
 with 2-groove barrels, 158
 Troop Trials, British Army, 26
 Thousand Pattern 1914 Rifles, 125-8
 Thousand Short Rifles, 78-83
 No. 1 Mark VI Rifles, 145
 German Army, 23, 25
 Tower of London, 158

 United Kingdom, 183, 188, 190, 194, 195
 U.S.A., 188, 202
 American Sniping Equipments, 172
 Eddystone Factory, 128
 Manufacture of Pattern 1914 Enfield Rifle, 128
 Manufacture of Rifle No. 4, Mark I*, 152, 153
 Ordnance, 154
 Remington Factory, 128
 Savage Arms Co., 154
 Stevens Arms Co., 154
 Winchester Factory, 128

 Vickers Machine-gun, 190, 192
 Vielle, M., 25
 Volunteer Forces, 48, 49

 War Office, Assistant Director-General of Ordnance, 61
 Choose new .22-in. rifle, 202
 Master-General of Ordnance, 179
 Questionnaires, 22, 56
 Recommend Magazine Rifle for British services, 26
 Small Arms Committee, 1864, 18; 1867, 20; 1883, 21, 23; 1900, 61
 agree to parallel rifling, 94
 consider a new rifle, 123, 124
 consider report from Somaliland, 90, 91
 receive new pattern rifle from Royal Small Arms factory, 83
 recommend adoption of Short Rifle, 83
 recommend adoption of new bullet, 115
 Secretary of State, 61
 approves manufacture of S.M.L.E., 73
 Weedon Ordnance Depot, 157
 Western Australia, 49, 54
 Wind effect at extreme ranges, 59, 60
 Woolwich Arsenal, 18
 Chief Inspector of Ammunition, 61
 Superintendent Royal Laboratory, 61
 World War I, 122, 128, 129, 180, 181, 187, 190, 207
 World War II, 128, 154, 164, 172, 173-6, 180, 181, 187, 190, 194-6, 201, 206

 Zululand, 54