



Large Hadron Collider Project

LHC Project Report 781

DESIGN OF THE BEAM LOSS MONITORING SYSTEM FOR THE LHC RING

B. Dehning, E. Effinger, G. Ferioli, J.-L. Gonzalez, E. Gschwendtner,
G. Guaglio, M. Hodgson, E.B. Holzer, V. Prieto, C. Zamantzas,
CERN, Geneva, Switzerland

Abstract

The beam loss monitoring (BLM) system of the LHC is one of the most critical elements for the protection of the LHC. It must prevent the super conducting magnets from quenches and the machine components from damages, caused by beam losses. It helps in the identification of the loss mechanism by measuring the loss pattern. Special detectors will be used for the setup and control of the collimators. Furthermore, it will be an important tool during machine setup and studies. The specification requirements of the BLM system include a very high reliability.

Presented at
EPAC 2004, Lucerne, Switzerland, 5 to 9 July 2004

CERN,
CH-1211 Geneva 23,
Switzerland

Geneva, July 2004

DESIGN OF THE BEAM LOSS MONITORING SYSTEM FOR THE LHC RING

Eva Barbara Holzer, Bernd Dehning, Ewald Effinger, Gianfranco Ferioli,
Jose Luis Gonzalez, Edda Gschwendtner, Gianluca Guaglio,
Michael Hodgson, Virginia Prieto, Christos Zamantzas,
CERN, Geneva, Switzerland

Abstract

The beam loss monitoring (BLM) system of the LHC is one of the most critical elements for the protection of the LHC. It must prevent the superconducting magnets from quenches and the machine components from damages, caused by beam losses. It helps in the identification of the loss mechanism by measuring the loss pattern. Special detectors will be used for the setup and control of the collimators. Furthermore, it will be an important tool during machine setup and studies. The specification requirements of the BLM system include a very high reliability.

INTRODUCTION

The loss of a very small fraction of the circulating beam may induce a quench of the superconducting magnets or even physical damage to machine components. The detection of the lost beam protons allows protection of the equipment against quenches and damage by generating a beam dump trigger when the losses exceed thresholds. In addition to the quench prevention and damage protection, the loss detection allows the observation of local aperture restrictions, orbit distortion, beam oscillations and particle diffusion, etc. Since a repair of a superconducting magnet would cause a down time of several weeks, the protection against damage has highest priority.

SPECIFICATION AND REQUIREMENTS

The criteria used to define the dynamic range of the measurement system are given by the calculated damage and quench levels and the expected usage. The observation time range is defined by the fastest possible use of a beam dump trigger signal by the beam dump itself and the response time of the helium temperature measurement system [1].

Quench level and observation range

The quench and damage levels are time and energy dependent (see Fig. 1) [2, 3]. The time dependence of the quench level for 450 GeV and the quench level for 7 TeV are drawn as well as the required observation range for these energies [1]. The required time resolution for the arc monitors is 2.5 ms and for all other monitors 89 μ s (1 turn). With this 1 turn resolution it will be possible to allow beam extraction with a delay of maximal three turns.

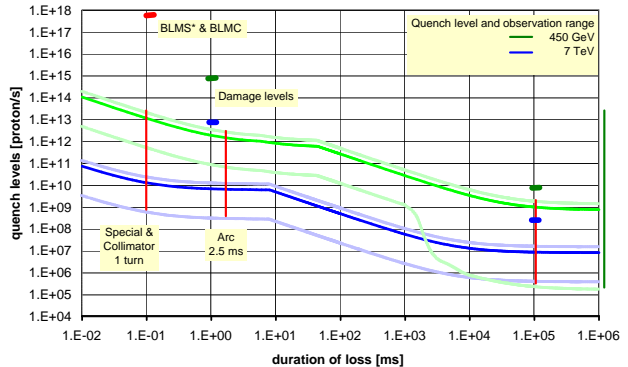

Figure 1: The LHC bending magnet quench level rates at 450 GeV and at 7 TeV are drawn as function of the loss duration (dark green and dark blue). The defined measurement range for both energies is indicated as well (bright green and bright blue).

The time resolution difference between arc monitors and all other monitors is motivated by the assumption that loss durations shorter than 2.5 ms can not occur at the arc locations [1]. The steady state observation limit in time is 100 s. The observation range for steady state losses at 450 GeV is extended to very low loss values, because an extrapolation of losses from the pilot bunch to some intermediate bunch intensity and bunch numbers should be possible. The damage levels are indicated at loss duration of 1 ms and 100 s (see Fig. 1). At 1 ms, the damage levels are 350 and 1000 times above the quench levels for 450 GeV and 7 TeV respectively. At 100 s they are 5 times and 25 times higher. The transition between injection energy and top energy is very non linear. The quench limits are reduced by 80 % if the beam energy is increased to 2 TeV [4].

Failure rate and availability

The measurement system failure rate and the availability requirements have been evaluated using the Safety Integrity Level (SIL) approach. A downtime cost evaluation is used as input for the SIL approach. The most critical systems, which contribute to the final SIL value for a safe beam extraction in case of dangerous beam particle losses, are the dump system, the interlock system, the beam loss monitor system and the energy monitor system. The beam loss monitor system is critical for short and intense parti-

cles losses, while at medium and longer loss durations it is assisted by other systems, such as the quench protection system and the cryogenic system.

At first it is estimated that a magnet damage will have a consequence of a downtime of LHC of about 30 days (see Table 1). This falls in the category of major consequences, which ranges between 20 days to 6 month. The assumed number of beam losses, which would have lead to a damage in the absence of the BLM system is estimated to be 100 per year. This falls in the category of frequent events and the needed failure probability is then given by 10^{-7} to 10^{-8} per hour (SIL 3) for a single beam loss monitor channel.

It is assumed that 10 false dumps per year could be accepted, which falls again in the category of frequent. The consequence of only 6 hours downtime falls in the minor consequence category. This is then leading to a failure probability of 10^{-6} to 10^{-7} per hour (SIL 3).

Table 1: Safety Integrity Level (SIL). The categories of frequencies and gravity are defined and the SIL levels corresponding to the failure rates are shown.

SIL levels determination	Gravity [downtime]			
	Catastrophic	Major	Severe	Minor
Frequency/y	> 6mon	20d-6mon	3d-20d	< 3d
Frequent > 1	SIL 4	SIL 3	SIL 3	SIL 2
Probable $10^{-1} - 1$	SIL 3	SIL 3	SIL 3	SIL 2
Occasional $10^{-2} - 10^{-1}$	SIL 3	SIL 3	SIL 2	SIL 1
Remote $10^{-3} - 10^{-2}$	SIL 3	SIL 2	SIL 2	SIL 1
Improbable $10^{-4} - 10^{-3}$	SIL 3	SIL 2	SIL 1	SIL 1
Negligible $< 10^{-4}$	SIL 2	SIL 1	SIL 1	SIL 1
SIL	Probability of dangerous failure/h			
4	$10^{-9} < Pr < 10^{-8}$			
3	$10^{-8} < Pr < 10^{-7}$			
2	$10^{-7} < Pr < 10^{-6}$			
1	$10^{-6} < Pr < 10^{-5}$			

MEASUREMENT PRINCIPLE

The measurement principle is based on the energy deposition detection of secondary shower particles using ionisation chambers [3] and on secondary emission monitors located outside of the magnet cryostats. The secondary particle fluence is linear with the initiating protons beam intensity and energy [5, 6]. To observe a representative fraction of the secondary particle fluence detectors are placed at likely loss locations. The calibration of the damage and quench level thresholds with respect to the measured secondary particle energy deposition is based on simulation.

LOCATION OF DETECTORS

Beam protons are likely to be lost at the location where the aperture is minimal. The locations of the smallest apertures are in the two collimation areas under nominal conditions. The next larger apertures limits are at 450 GeV at the arc quadrupole magnets and at 7 TeV at the final focus magnets of the experimental insertions and some other loca-

tions. The loss locations and the longitudinal distributions are simulated using the aperture model of the LHC ring and taking into account the scattering processes in the collimation areas [7, 8]. The beam loss monitors are located on either side of the magnets in the horizontal plane defined by the beam vacuum tubes. Their longitudinal positions are about 1 m downstream of the most likely loss locations (see Fig. 2). The bellow locations between quadrupole mag-

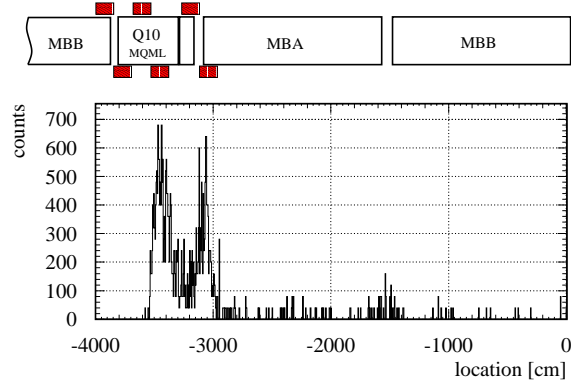

Figure 2: Scheme of the beam loss monitor locations in the vicinity of a quadrupole magnet (top). The simulated longitudinal particle shower distribution at the outside of the cryostat surface traversing a stripe with a height of 5 cm in respect to the horizontal plane (bottom) is shown. The initiating proton impact position is at the centre of the quadrupole magnet

nets and bending magnets are among the anticipated loss locations. Another likely loss location at the entrance of a focussing quadrupole magnet will be defined using the proton loss map simulations. The location optimisation of the monitors will be done using the criteria of maximum signal detection and the ability to distinguish between beam one and beam two of the LHC. The lateral monitor position is

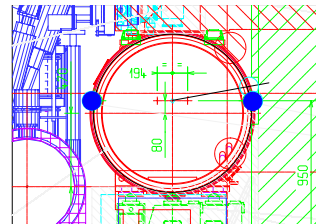

Figure 3: Cross section drawing of the LHC tunnel with the cryo line (lower left corner) and the cryostat of a quadrupole magnet. The beam loss detectors are indicated by the two blue circles

shown in figure 3. At this position the secondary particle fluence is highest and the best separation of the losses from the two beams is reached.

DETECTORS

The large proton loss intensity range requires the use of two different detectors and detection principles. The majority of the detectors of the BLM system will be ionisation chambers (3500) and, for regions with very high loss rates, secondary emission monitors (SEM) are foreseen (see Fig. 4).

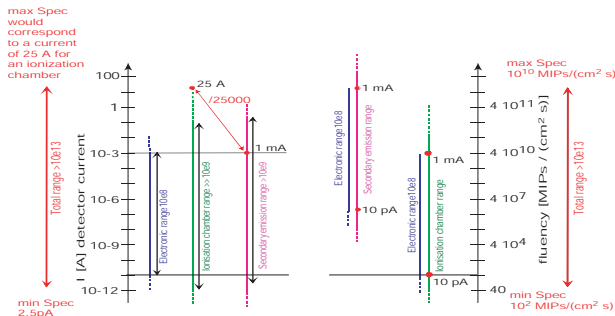

Figure 4: Left: Range of detector currents and range of the acquisition electronics. Right: Range of the detectable minimum ionising particle rate density.

The ionisation chamber consists of a stack of parallel electrodes, which is inserted in a stainless steel tube. The volume of the chamber is filled with gas (N₂ in the SPS) under normal pressure. The electrical field strength in between of the electrodes is 3 kV/cm. The SEM detector will be based on the same design as the ionisation chamber. Instead of having the electrode volume filled with a gas it will be under vacuum and only one sensitive foil will be used to reduce the sensitivity (see Fig. 5, middle foil).

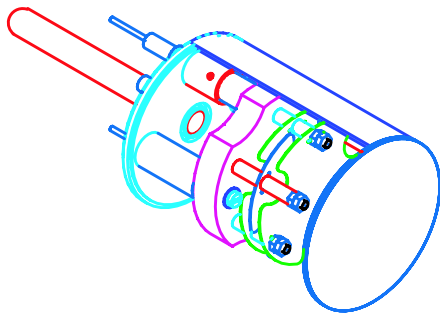

Figure 5: Design drawing of the secondary emission monitor (diameter 89 mm, length 100 mm).

ACQUISITION SYSTEM

The electrical signals of the detectors are digitised with a current to frequency converter and these pulses are counted over a period of 40 μ s (see Fig. 6). The counter value is transmitted every 40 μ s to the surface analysis electronics using a dedicated fibre link. The surface electronics compares the measured loss values with the loss duration and the beam energy depended threshold values. Warning information is transmitted by a software protocol. The dump

signals are transmitted to the dump kicker magnets using the beam interlock system (BIC). The beam energy information is received over a dedicated redundant fibre link. The signal treatment and transmission chain is redundant after the current to frequency conversion to meet the required failure rate probability of 10⁻⁷ to 10⁻⁸ per hour. The analog electronics is located below the quadrupole magnets in the arc. For all detectors of the dispersion suppressor and the long straight sections the electronics is located in the LHC side tunnels (see Fig. 6). The analog signal transmission cables have a length of a few meters (arc) to up to 300 m (long straight section). This part of the transmission is subject to the injection of electromagnetic cross talk and noise. It is foreseen to use the same electronics for the two detector system.

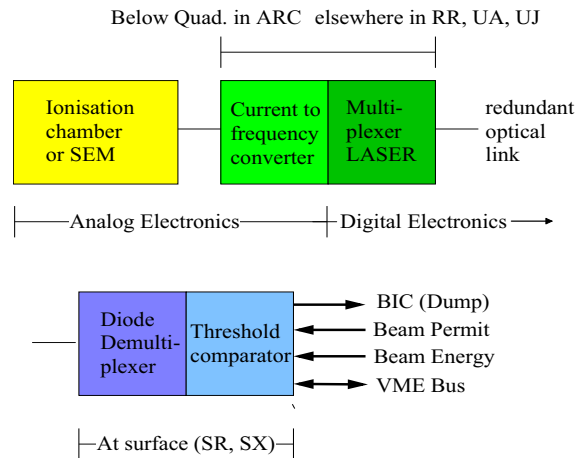

Figure 6: Schematic view of the BLM detector and signal transmission chain

REFERENCES

- [1] J. B. Jeanneret and H. Burkhardt, "Measurements of the Beam Losses in the LHC Ring", LHC-BLM-ES-0001.20
- [2] J.B. Jeanneret, D. Leroy, L. Oberli and T. Trenkler, LHC Project, "Quench levels and transient beam losses in LHC magnets", LHC Report 44, CERN, July 1996.
- [3] A. Arauzo-Garcia et al., "LHC Beam Loss Monitors", 5th European Workshop on Diagnostics and Beam Instrumentation DIPAC 2001, Grenoble, France, CERN-SL-2001-027-BI.
- [4] B. Dehning, "Beam Instrumentation for Machine Protection", Workshop of LHC performance, Chamonix, France, 2003, CERN-AB-2003-008-ADM.
- [5] A. Arauzo and C. Bovet, "Beam loss detection system in the arcs of the LHC", CERN-SL-2000-052-BI.
- [6] A. Arauzo and B. Dehning, "Configuration of the beam loss monitors for the LHC arcs", LHC Project Note 238.
- [7] E. B. Holzer, B. Dehning, "Longitudinal Beam Loss Distribution along the LHC Ring", these proceedings.
- [8] R. Assmann et al., "Expected Performance and Beam-based Optimization of the LHC Collimation System", these proceedings.