

+

EUROPEAN ORGANIZATION FOR NUCLEAR RESEARCH
CERN – PS DIVISION

PS/OP/Note/2002-040

**The CERN Antiproton Decelerator (AD)
Operation, Progress and
Plans for the Future**

P.Belochitskii, T.Eriksson
(For the AD machine team)

Abstract

The CERN Antiproton Decelerator (AD) is a simplified source providing low energy antiprotons for experiments, replacing four machines: AC (Antiproton Collector), AA (Antiproton Accumulator), PS and LEAR (Low Energy Antiproton Ring), shut down in 1996. The former AC was modified to include deceleration, electron cooling and ejection lines into the new experimental area. The AD started physics operation in July 2000 and has since delivered cooled beams at 100 MeV/c (kinetic energy of 5.3 MeV) to 3 experiments (ASACUSA, ATHENA and ATRAP). Problems encountered during the commissioning and the physics runs will be outlined as well as progress during 2001 and possible future developments.

Paper presented at the PBAR01 conference
Aarhus, Denmark, 14-15 September 2001

Geneva, Switzerland
10 March 2002

1 INTRODUCTION

History of the AD project:

- June 1995, SPSLC: ‘whatever support CERN can provide for the spectroscopy of antihydrogen experiments to access an antiproton source will be important’.
- 1996: Deceleration tests in AC, Design report published, ADUC formed (AD users committee) [Ref. 1].
- February 1997: AD project approved (with strong financial and manpower support from the user community).
- 23 November 1998: Proton beam decelerated to 300 MeV/c
- November 1999: First antiprotons ejected to experiments at 100 MeV/c (no cooling at 100 MeV/c). First ASACUSA experimental results.
- 10 July 2000: Start of first long physics run

In comparison with the previous CERN low energy antiproton scheme, the AD is an economic pbar source:

One ring (AD) with pbars is used instead of four: AC, AA, PS, and LEAR.

Power consumption is down from approximately 8 MW to ~0.5 MW.

No dc powered 3.57 GeV/c storage rings are used any more.

90 % of the AC equipment could be re-used: magnets, rf, stochastic cooling etc. The electron cooler comes from LEAR.

Basically a ~80 MCHF machine was obtained for only ~8 MCHF upgrade cost (control system, vacuum system, power supplies and beam diagnostics).

The new experimental area was added inside the AD building.

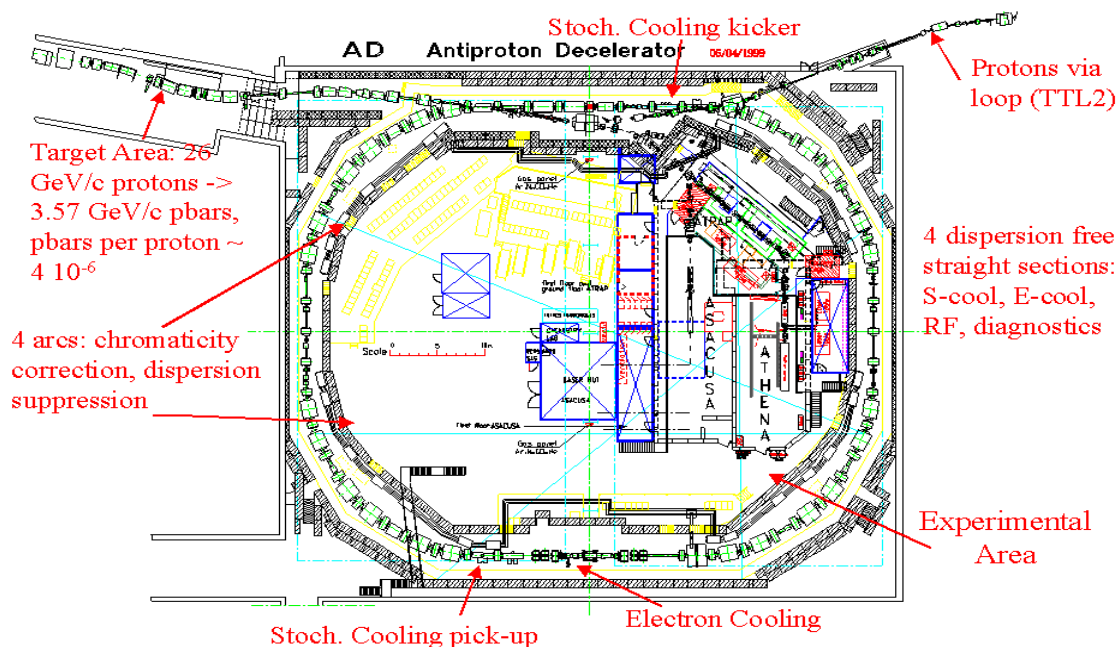

Fig. 1 - Overview of the AD

2 HOW THE AD WORKS

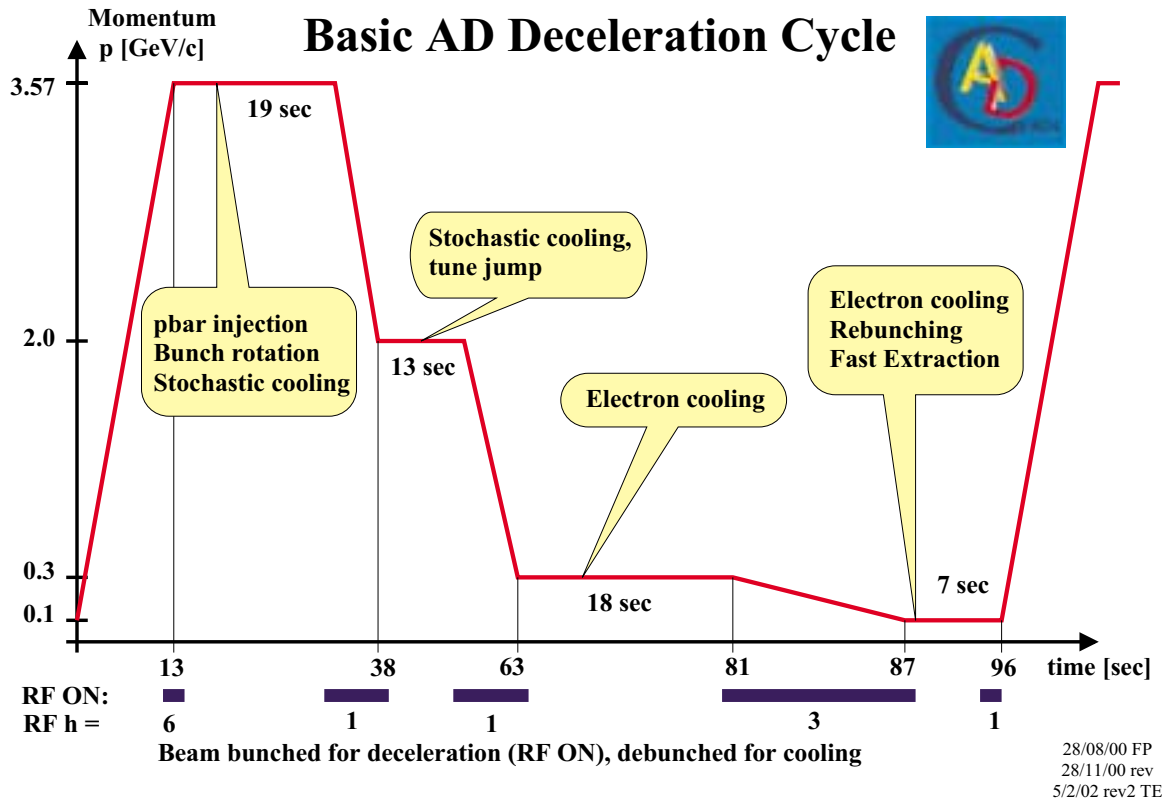

Fig. 2 - AD deceleration cycle

Protons are ejected from PS with a momentum of 26 GeV/c and transferred to the target. There antiprotons are produced and transferred to the AD ring. After injection at 3.57 GeV/c, antiprotons are rotated by 90° in the longitudinal phase space, taking advantage of the large AD momentum acceptance and short bunch length of about 25 ns. The beam is then debunched and stochastically cooled to avoid losses due to beam blow-up during deceleration. With small emittances after stochastic cooling the beam is then bunched (at harmonic number 1), decelerated down to 2 GeV/c and stochastically cooled again, mainly to reduce momentum spread to fit requirements of the deceleration rf cavity. After the end of the stochastic cooling, the AD tunes are changed from $Q_x = 5.385$, $Q_y = 5.37$ to $Q_x = 5.45$, $Q_y = 5.42$, taking advantage of the small emittances to cross the 5th order resonance $5Q_x = 27$. The first working point provides maximum machine acceptance at injection energy, while the second places the beam in a region of the tune diagram where more resonance free space is available, which is particularly important at low momenta. (See Fig.3)

The beam is then decelerated down to 300 MeV/c and cooled by the electron beam from the e-cooler. After cooling, the beam is rebunched at harmonic number 3 (the deceleration rf-cavity operates in the range 0.5 – 1.6 MHz) and decelerated to the ejection momentum of 100 MeV/c (kinetic energy 5.3 MeV). Then the antiprotons are again cooled by the electron beam, rebunched at harmonic number 1 to extract all particles in one bunch (here the rf cavity resonant frequency is lowered to 174 kHz by means of a relay switched capacitor), rotated 90 degrees in the longitudinal phase space (if experiments demand shorter beam, which is typically the case) and ejected.

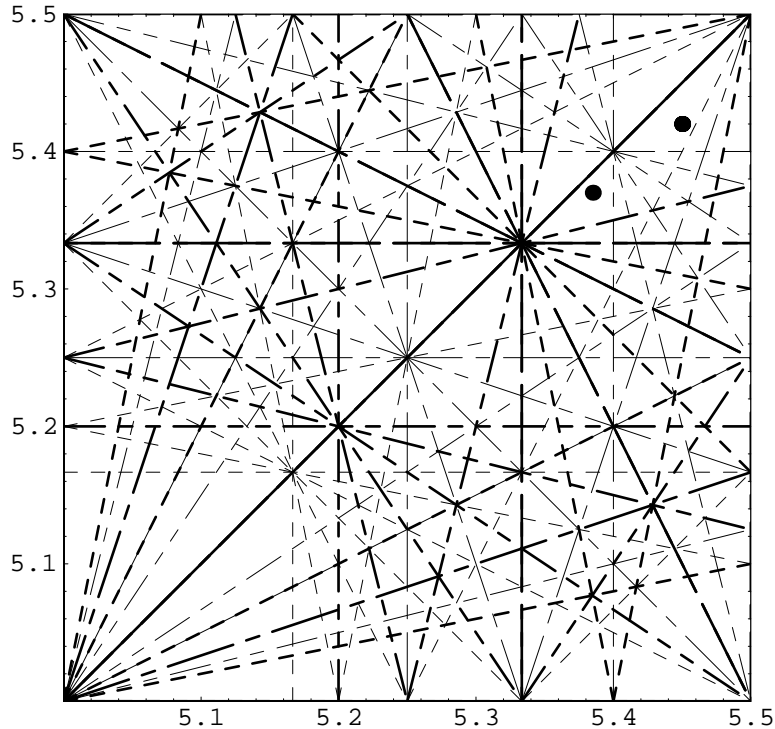

Fig.3 AD tune diagram. Resonances up 6th order are shown.

Apart from running the AD in the normal antiproton operation mode, higher intensity (a few 10^9 particles) proton beams can be injected for machine setting up and development. Initial setting up of the beam cooling systems was done with protons circulating in the normal (CW) direction, this requires the target to be moved out of its normal position and the ring magnets to be switched to reverse polarity. Protons can also be injected backwards through the old AA ejection line and made to circulate in the reverse direction (CCW). However, in this mode no beam cooling is possible which in turn makes it difficult to decelerate to low energies.

3 BEAM DIAGNOSTICS

The AD project was challenging due to low beam intensities and low beam energy [2]. Typically, pbar beams of 10^7 particles were decelerated to 100 MeV/c.

The closed orbit measurement system was upgraded with ultra low noise head amplifiers [3]. After an additional EMC upgrade, excellent results were obtained making it possible to measure closed orbits at 100 MeV/c with only 10^7 particles circulating and with a precision of ± 0.2 mm. Thanks to this achievement, most of the AD setting up can now be done with antiprotons.

A new low frequency (0.3 – 30 MHz) longitudinal Schottky pickup was installed and performed as expected. Bunched beam intensities can now be monitored during the whole AD cycle with enough precision to accurately locate losses [4]. The same pickup is also used to monitor momentum distribution and as rf phase loop pickup.

The new low frequency (5-7 MHz) transverse Schottky pickups performed somewhat worse than expected [2], but can nevertheless be used for BTF tune measurements.

Scrapers and scintillators were recuperated from the AC and are routinely used for destructive beam profile measurements, which have proved to be important in keeping the beam cooling systems properly adjusted [5].

Non-destructive profile measurements will be done in the future with the new Beam Ionisation Profile Monitors. Initial tests have been done with promising results [6].

4 AD COMMISSIONING: CHALLENGES AND PROBLEMS

The AD commissioning was longer than expected and difficult due to many reasons [2]:

- Low beam intensities made beam diagnostics difficult (tune, orbit and intensity measurements).
- Fairly complicated machine optics [7] (change of the working point during the cycle, strong linear coupling caused by the main solenoid of the electron cooler, lack of space in the machine to locate dipoles for orbit correction and especially beam trajectory adjustments w.r.t. to electron beam of electron cooler, different magnetization curves for the different quadrupoles powered with the same power supply etc.)
- Slow eddy current effects in magnet end plates were cured by special programming of the magnet currents to compensate for the field lag.
- Poor tracking of one of the AD half-quadrupoles QFC54 w.r.t. the other quadrupoles powered by the same power supply: the difference in gradient is about 12%, this produces a beta function beating of up to 100% in the horizontal plane. An additional power supply was installed to solve the problem.
- Strong requirements on the power supplies caused by the wide momentum range (factor 36), causing stability problems.
- Orbit fluctuations at low momenta.
- Inadequate quality control at the beginning.
- Contradictory experience with “protons via loop” operation: due to fluctuating parameters of the magnetic elements in the old TTL2 transfer line, the injected beam has significant orbit offset and/or angle error causing large emittance blow-up.

Nevertheless, starting in July 2000, antiproton beams were regularly delivered to the experiments. After commissioning, the machine performance gradually improved, resulting in higher ejected beam intensity and smaller beam emittances. Towards the end of year 2000, the intensity of the beam at ejection energy 5.3 MeV was $2 \cdot 10^7$ antiprotons per shot with a deceleration efficiency (number of ejected antiprotons/number of injected antiprotons) of 50% to 70% (estimated from the bunched beam intensity measurements based on use of the low frequency longitudinal Schottky PU).

5 AD PROGRESS IN 2001: INCREASING THE BEAM INTENSITY

Most of the machine development work done by the AD team has been concentrated on increasing the intensity of the injected beam and minimization of the beam losses during the cycle.

The intensity of the proton production beam from PS was increased from $1.1 \cdot 10^{13}$ to $1.5 \cdot 10^{13}$, at the same time taking precautions to avoid blow up of the horizontal emittance at PS injection. Vertical machine acceptance was increased from 180π .mm.mrad to 200π .mm.mrad due to better alignment of several AD magnetic elements as well as position pickups during the winter machine shutdown. This was followed by better orbit correction at start up. The horizontal machine acceptance was also improved from 165π .mm.mrad to 180π .mm.mrad, yet smaller than the design value of 200π .mm.mrad.

The losses during the AD cycle were carefully analysed. Most of the losses occurred during the ramps between injection energy and 2 GeV/c and between 2 GeV/c and 300 MeV/c due to 50 Hz (150 Hz, 250 Hz) related voltage modulation. By improving the signal transmission of the analogue rf program to the deceleration cavity the problem was solved.

Losses during the ramp from 300 MeV/c to 100 MeV/c were eliminated by improving electron cooling at 300 MeV/c (Table 1) and implementing a more sophisticated linear coupling compensation scheme. During the commissioning the linear coupling compensation was done by two compensating solenoids connected in series with the main solenoid of the electron cooler and by two skew quadrupoles connected to a common power supply. The following winter shutdown (year 2000), the two compensating solenoids and the two skew quadrupoles were equipped with individual power supplies. This allowed, along with suppression of the difference resonance $Q_x - Q_y = 0$ (by minimization of the distance between normal modes) significant reduction of the stop band for the sum resonance $Q_x + Q_y = 11$ (based on the knowledge of the operational optics by means of orbit response measurements). After that the available space in the tune diagram that provides best beam lifetime at 100 MeV/c was significantly increased.

At present the deceleration efficiency in routine machine operation is around 95% with a peak value of 100%.

Summing up the contribution from all sources, the routine intensity of the ejected beam is now about $3 \cdot 10^7$ antiprotons, which is 50% more than last year.

AD PROGRESS IN 2001: REDUCTION OF THE CYCLE LENGTH

The recent progress in the electron cooling performance (Table1) allowed a reduction in cooling time at 300 MeV/c from 15 s to 10.2 s and at 100 MeV/c from 11.6 s to 3.2 s. The total AD cycle length was reduced by one PS supercycle duration and is now 96.4 s (less than 7 PS supercycles of 14.4 s duration or 6 supercycles of 16.8 s duration).

The design value for the AD cycle is 60 s. Limiting factors for further cycle length reduction are:

- Electron cooling is still slower than expected. While at 100 MeV/c it is 3.2 s and it is hard to reduce it further due to slow eddy current effects, at 300 MeV/c it could be optimised further. The limitation comes from the lack of strength in the dipoles that adjust antiproton orbit w.r.t. electron orbit. This can be solved by implementing another scheme of orbit manipulation inside of the electron cooler, where combined dipoles (marked HV on Fig. 4) are exchanged with the vertical dipoles, taking advantage of the bigger phase advance between kicks in the horizontal plane, hence essentially reducing required strength of dipole for a given local orbit bump.
- Cycle programming and timing system limitations.
- Maximum dB/dt is lower than foreseen. The cycle ramps are longer than expected (22 s total instead of 8 s mainly due to the slow eddy current effects: AC magnets that used now in AD were designed for machine operation at fixed energy).

At present it seems possible to reduce the AD cycle length by one PS supercycle duration. This can be achieved by a further reduction of the electron cooling time at 300 MeV/c and by some modifications to the timing system. A small reduction of the stochastic cooling time can be considered as well. The ramps will be studied carefully and shortened if possible using the recently made available tune measurement system, which can measure tunes during the ramps [8]. The reduction of AD cycle length will increase the number of antiprotons per second delivered to experiments and provide a basis for reduction of accumulation time in traps. In addition, it saves time required for transfer line adjustment, because at present only destructive measurements are available for beam position measurements.

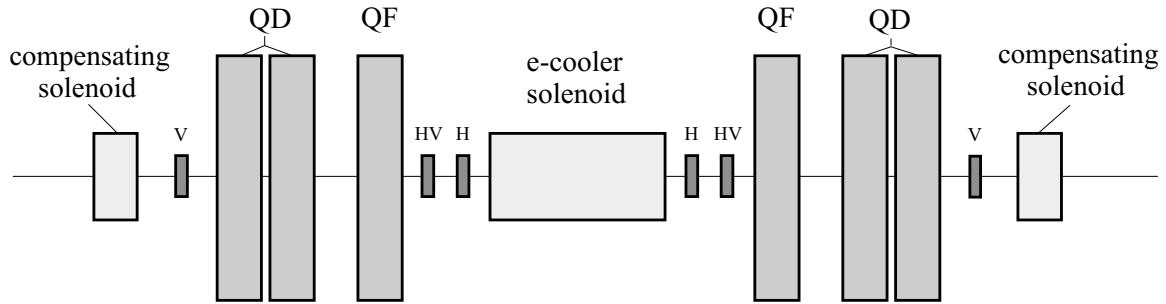

Fig. 4 - Schematic view of the AD electron cooling insertion

Table 1 – Beam cooling performance

Momentum (GeV/c)	Cooling system	Final emittances (95% beam)						Cooling time (s)
		Obtained in September 2002			Design aim			
		Hor. (π mm.mrad)	Vert. (π mm.mrad)	$\delta p/p$ (%)	Hor. (π mm.mrad)	Vert. (π mm.mrad)	$\delta p/p$ %	
3.5	Stochastic	3	4	0.07	5	5	0.1	19
2.0	Stochastic	3	3	0.015	5	5	0.03	9
0.3	Electron	2.7	2.7	0.01	2	2	0.1	10
0.1	Electron	0.3*	0.3*	0.01	1	1	0.01	3

(*) 85% of the beam

AD PROGRESS IN 2001: TRANSFER LINES FROM AD TO EXPERIMENTS

Recently a new beam transformer has been installed in the common part of the ejection line. With an estimated precision of a few percent, it provides reliable information about the intensity of the beam extracted to the experiments. It also has been used to correct the calibration factor used in DSP-based circulating beam intensity measurements using the longitudinal Schottky pickup.

To speed up transfer line adjustments, ABS (Automatic Beam Steering) has been tested and is planned to be used in operation. Further improvement of the beam transmission and significant simplification of the transfer line settings adjustment could be achieved with installation of electrostatic pickups that have the advantage of non-destructive measurements and, in addition to beam position also allow monitoring of the intensity.

Table 2. Extracted beam characteristics obtained by September 2001

Parameter	Obtained September 2001	Design aim
Momentum [MeV/c]	100	100
Intensity [pbars per pulse]	$3.0 \cdot 10^7$	$1.2 \cdot 10^7$
Deceleration efficiency (3.57 GeV/c – 100 MeV/c) [%]	95	25
Cycle repetition time [s]	100	60
Minimum bunch length [ns]	220	200
$\delta p/p$ (debunched)	$1 \cdot 10^{-4}$	$1 \cdot 10^{-4}$
$\delta p/p$ (bunched)	$2 \cdot 10^{-3}$	$1 \cdot 10^{-3}$

6 RUN STATISTICS – BEAM AVAILABILITY

Table 3. AD run statistics 2000/2001

	2000		2001 (Until Sept.)	
Scheduled hours	4030		3200	
	Effective hours	Uptime (%)	Effective hours	Uptime (%)
Total	3513	73.4	2330	85.0
ASACUSA	570	89.1	621	91.4
ATHENA	222	75.2	401	82.7
ATRAP	669	86.1	575	92.4
MD	2051	73.7	733	76.8

7 OPERATION IN 2002 AND BEYOND

- The AD is scheduled to run 3000 hours per year (physics + startups + md).
- Operation starts Mondays at 07:00 and ends Fridays at 23:00.
- Until the end of 2001: 3 operators from the experiments and 2 from CERN PS/OP will ensure shift operation 24h/24.
- From 2002: 2 additional operators from PS/OP will be trained on the AD.
- Beyond 2002: 4 operators will be on call on a weekly basis while the PS MCR crew will ensure the routine aspects of operation.

8 CONCLUSION

After one and a half year of running for physics, the AD routinely delivers about $3 \cdot 10^7$ particles in one bunch with a repetition rate of about 100 seconds to the experiments. The number of antiprotons per second is approximately 1.5 times larger than the design value. The deceleration efficiency is close to 100%. Electron cooling at 100MeV/c needs to be improved further. The reduction in cycle length is expected to be accomplished without major problems and will provide about 15% gain in beam intensity per second. Special attention is paid to machine stability at ejection energy, which is the most crucial point.

References:

1. S. Baird et al, *Design study of the AD*, CERN/PS 96-43(AR), 1996.
2. F. Pedersen, S. Maury, *AD machine and areas*, Proc. PS Days Evian 2001.
3. M. LeGras, L. Soby, D.J. Williams, *The closed orbit system for the AD*, Proc. DIPAC 1999, Chester, UK.
4. M.E. Angoletta et al, *The new Digital Receiver based system for Antiproton beam diagnostics*, Proc. PAC 2001, Chicago, Illinois, USA, June 18-22 2001, p. 2371.
5. V. Chohan et al, *Beam measurement systems for the CERN Antiproton Decelerator (AD)*, Proc. PAC2001, Chicago, Illinois, USA, June 18-22 2001, p.2302.
6. G. Tranquille et al, private communication.
7. P. Belochitskii et al, *Optics for the antiproton decelerator at CERN*, Proc. PAC2001, Chicago, Illinois, USA, June 18-22 2001, p.2563.
8. O. Marquersen et al, *Real Time Tune Measurements on the CERN Antiproton Decelerator*, Proc. DIPAC 2001, Grenoble, France.