

GANIL

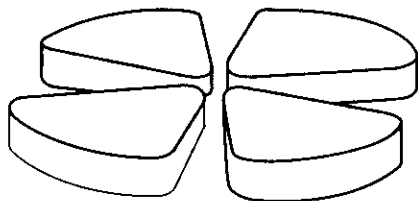

To be published in the proceeding of the 9th International Conference on Ion Sources
- Oakland, USA - September 3-7, 2001. Rev. Sci. Instr

ION SOURCE DEVELOPMENT AT GANIL FOR RADIOACTIVE BEAMS AND HIGH CHARGE STATE IONS.

R. Leroy, C. Barué, C. Canet, M. Dupuis, J-L. Flambard, G. Gaubert,
S. Gibouin, Y. Huguet, P. Jardin, N. Lecesne, P. Lehérissier, F. Lemagnen,
L. Maunoury*, J-Y. Pacquet, F. Pellemoine-Landré, J-P. Rataud, M.G. Saint-Laurent
and A.C.C. Villari

GANIL, B.P. 5027, 14076 Caen Cedex 05, France
* CIRIL, B.P. 5133, 14070 Caen Cedex 05, France

CERN LIBRARIES, GENEVA



CM-P00042127

GANIL A 01 07

#2293233

ION SOURCE DEVELOPMENT AT GANIL FOR RADIOACTIVE BEAMS AND HIGH CHARGE STATE IONS.

R. Leroy, C. Barué, C. Canet, M. Dupuis, J-L. Flambard, G. Gaubert,
S. Gibouin, Y. Huguet, P. Jardin, N. Lecesne, P. Lehérissier, F. Lemagnen,
L. Maunoury*, J-Y. Pacquet, F. Pellemoine-Landré, J-P. Rataud, M.G. Saint-Laurent
and A.C.C. Villari

GANIL, B.P. 5027, 14076 Caen Cedex 05, France
* CIRIL, B.P. 5133, 14070 Caen Cedex 05, France

Abstract

The GANIL laboratory has in charge the production of ion beams for nuclear and non nuclear physics. This article reviews the last developments that are underway in the fields of radioactive ion beam production, increase of the metallic ion intensities and production of highly charged ion beams.

1 THE RADIOACTIVE ION BEAM PRODUCTION.

With the SPIRAL facility, GANIL deals with the production of unstable nuclei beams for nuclear physics. The principle of the production consists in the fragmentation of stable atoms by interaction of the high energy beam delivered by the current cyclotrons (called primary beam) with a thick target where all the reaction products are stopped. The target is thereby heated by the primary beam up to 2300 K that fastens the diffusion of radioactive nuclei outside the target. A numerical code has been developed to simulate the temperature distribution inside the target and is described in reference 1.

The radioactive atoms effuse to the ion source where they are ionized and extracted to form the radioactive ion beam that can be accelerated by a cyclotron in the case of the SPIRAL apparatus.

The number of radioactive atoms created by this method usually called ISOL depends on the primary beam intensity and on the integrated fragmentation cross section. However the creation rate of nuclei of interest is always low and the major problem of the method is to be as efficient as possible in order to maintain a suitable radioactive ion beam intensity. This means that the system of production of the radioactive ion beam has to take into account all the losses process that can occur like sticking on the

walls, leaks, chemical reactions, etc... The production time including diffusion out of the target, effusion, ionization, confinement, etc... has to be lower than the life-time of the nuclei of interest.

In order to test the properties of the target ion source systems a separator called SIRa² was built some years ago. It has allowed the test of different configurations^{3, 4, 5} of production systems under real conditions.

The last configuration that has been tested is the target ion source, called nanogan3, that equips now the SPIRAL facility.

1.A THE NANOGAN3 CONFIGURATION.

The SPIRAL facility uses a cyclotron for the radioactive ion beam acceleration that implies the use of multicharged ions. The nanogan3 configuration is composed of a graphite target coupled to a 10 GHz permanent magnet electron cyclotron resonance ion source via a cold transfer tube. This configuration is mainly dedicated to gaseous elements that do not stick on the walls. Figure 1 shows the target ion source assembly.

Different tests have been performed for radioactive noble gas production and the measured intensities are resumed in table 1. For ⁶He and ⁸He, a new target has been developed which is divided

into two parts due to the long range of ^8He in carbon (see reference 6).

Radioactive oxygen beams have been produced by using the fact that a radioactive oxygen produced in the graphite target can combine with the carbon and produce a CO molecule that diffuses to the ion source. The intensity of ^{14}O are given in table 1.

In all cases, except for O production, reliability tests have been successfully performed during long time (more than 20 full days).

The SPIRAL facility has received the starting authorizations coming from the safety administrations and the first beam will be produced at the end of this month.

1B THE MONO1001 CONFIGURATION

Another method for producing multicharged radioactive ion beams consists in producing a monocharged ion beam and in stopping these ions inside the plasma of an ecr ion source in order to increase the charge state. This technique⁷, called $1+/n+$, has been developed and studied by the ISN group in Grenoble, France in collaboration with GANIL. The GANIL has in charge now to develop the monocharged target ion source system taking into account the specificities of radioactive ion beam production.

A new 2.45 GHz ion source, called mono1001, has been built and tested with stable ions. An ionization efficiency of 90% for Ar^+ has been obtained and some test of $1+/n+$ transformation have been performed on the ISN test bench that showed that the $1+/n+$ transformation efficiency was not different with mono1001 than with the other sources used in Grenoble⁸.

One of the great advantages of this source is the large access to the plasma and the possibility to place a target very close to the plasma, suppressing by this way the losses due to effusion between the target and the source (see figure 2). The next tests that will be made in the

near future will consist in producing the radioactive ion beam. They will be run at GANIL on the SIRa test bench and at ISOLDE at CERN.

A detailed description of the source and the last results are given in these proceedings in reference 9.

1C THE MONOLITHE CONFIGURATION

In the case of alkali elements, the use of a surface ionization source can lead to high efficiencies. The target is divided into two parts: the first one called "production target" stops the primary beam and is cooled. The second one, called diffusion target, is heated by an extra ohmic heater and stops the radioactive nuclei providing from the fragmentation of the primary beam. The radioactive atoms have then to effuse through a small transfer tube where they are ionized and extracted (see figure 3).

A first prototype has been built and the efficiency has been measured by injecting a high energy radioactive beam inside the target instead of the primary beam¹⁰. This method has given for ^{21}Na (22,48 s) a total efficiency (that includes the diffusion and the ionization efficiencies) in the range of 10 to 50% depending on the implantation deepness of the radioactive primary beam. This result proves that the losses in this case are mainly due to diffusion from the target and that the ionization efficiency is better than 50%.

Further tests will be done during the next year.

2 THE PRODUCTION OF METALLIC IONS

For physicists and for radioactive ion beam production, it is important to increase the intensity of the primary beam, and in particular for metallic species.

Some progress have been performed in this field by adapting the MIVOC method to our ECR ion sources. A 20 μA beam of $^{58}\text{Ni}^{11+}$

has been produced during 8 full days by using nickelocene and an intensity of 92 μA of $^{56}\text{Fe}^{9+}$ has been reached with ferrocene.

In parallel with these tests, the $^{48}\text{Ca}^{9+}$ intensity has been increased by using metal calcium with a low consumption rate and a good ionisation efficiency.

A detailed description of all these tests and of the methods that have been used is given in reference 11.

3 THE HIGH CHARGE STATE ION PRODUCTION

The GANIL has also in charge in collaboration with the CIRIL laboratory to produce low energy beams for non nuclear physics. The Limbe facility has been built in order to deliver ion beams with good optical properties. A detailed description of the Limbe beam lines is given in these proceedings in reference 12.

The ion source that delivers the beam is a supershybie ECR ion source that combines the use of coils and of permanent magnets for the creation of the axial magnetic field (see reference 5). The HF wave is injected inside the source through a circular guide with 19 mm of inner diameter. This transition allows working with 1 kW of HF power during several days without any heating problem. The demands of physicists mainly consist in very high charge state ions like $^{40}\text{Ar}^{17+}$ or $^{40}\text{Ar}^{18+}$. Table 2 gives the beam intensities that have been furnished during long periods (several days) with a very good stability and a high reliability and reproducibility.

In the near future, the beam optic after the source will be upgraded in order to increase the magnetic rigidity and the mass resolution of the Limbe facility.

REFERENCES

- 1 R. Lichtenthäler et al, NIM B, 140 (1998) 415-425
- 2: R. Anne et al, Proceedings of the Part. Acc. Conf., Washington, USA, 17-21 Mai 1993
- 3: N. Lecesne, et al, Proceedings of the 15th Int. Conf. On cyclotrons and their applications, Caen, France, 14th-19th June 1998
- 4: L. Maunoury et al, Proceedings of the 18th Int. Workshop on ECR Ion Sources, February 26-28, College Station, Texas USA (1997)
- 5: R. Leroy et al, Proc. of the 14th Int. Workshop on ECR Sources, CERN, Geneva, Switzerland, 3-6 May 1999
- 6: A.C.C. Villari et al Proceedings of. CAARI 2000, Denton, TX, USA (2000)
- 7: T.Lamy et al, Proceedings. of the 14th Int. Workshop on ECR Sources, CERN, Geneva, Switzerland, 3-6 May 1999
- 8: N. Chauvin, PHD Thesis, n° ISN 00-76, ISN Grenoble, France, (2000)
- 9: P. Jardin et al, these proceedings
- 10: N. Lecesne et al, Proceedings of the 13th International Conference EMIS 13, Bad Dürkheim, Germany, September 23-27 1996, NIM B126 (1997) 141
- 11: P. Leherissier, these proceedings.
- 12: L. Maunoury et al, these proceedings.

Radioactive beam	Live time (s)	Primary beam Primary beam energy	Intensity (pps)
${}^6\text{He}^+$	0.8	${}^{13}\text{C}$ 75 MeV/A	$3.2 \cdot 10^8$
${}^8\text{He}^+$	0.12		$2.0 \cdot 10^6$
${}^{17}\text{Ne}^{5+}$	0.11	${}^{20}\text{Ne}$ 95 MeV/A	$8 \cdot 10^5$
${}^{18}\text{Ne}^{5+}$	1.67		$4.4 \cdot 10^7$
${}^{19}\text{Ne}^{5+}$	17.22		$4.4 \cdot 10^7$
${}^{32}\text{Ar}^{7+}$	0.098	${}^{36}\text{Ar}$ 95 MeV/A	$1.6 \cdot 10^3$
${}^{32}\text{Ar}^{8+}$	0.098		$2.5 \cdot 10^3$
${}^{33}\text{Ar}^{8+}$	0.174		$1.8 \cdot 10^5$
${}^{34}\text{Ar}^{7+}$	0.844		$6.1 \cdot 10^6$
${}^{34}\text{Ar}^{8+}$	0.844		$1.2 \cdot 10^7$
${}^{35}\text{Ar}^{8+}$	1.77		$3.1 \cdot 10^8$
${}^{14}\text{O}^{6+}$	70	${}^{16}\text{O}$ 95 MeV/A	10^6
${}^{14}\text{O}^{5+}$	70		$1.3 \cdot 10^6$

Table 1: Radioactive ion beam intensities measured on the SIRa test bench and normalized to 2 kW of primary beam power

Ion	Intensity (eμA)	Ion	Intensity (eμA)
He ⁺	1500	Ar ⁸⁺	250
He ²⁺	1500	Ar ¹⁴⁺	23
C ⁴⁺	250	Ar ¹⁶⁺	1.9
O ⁶⁺	450	Ar ¹⁷⁺	0.08
O ⁷⁺	140	Ar ¹⁸⁺	4.10 ⁻⁴
N ⁷⁺	3.5	Kr ¹⁶⁺	50
Ne ⁸⁺	170	Kr ²⁴⁺	5.2
Ne ⁹⁺	14.5	Xe ²³⁺	11
Ne ¹⁰⁺	1.2	Xe ²⁷⁺	4.2

Table 2: High charge state ion beam intensities after the analysing magnet on the limbe apparatus.

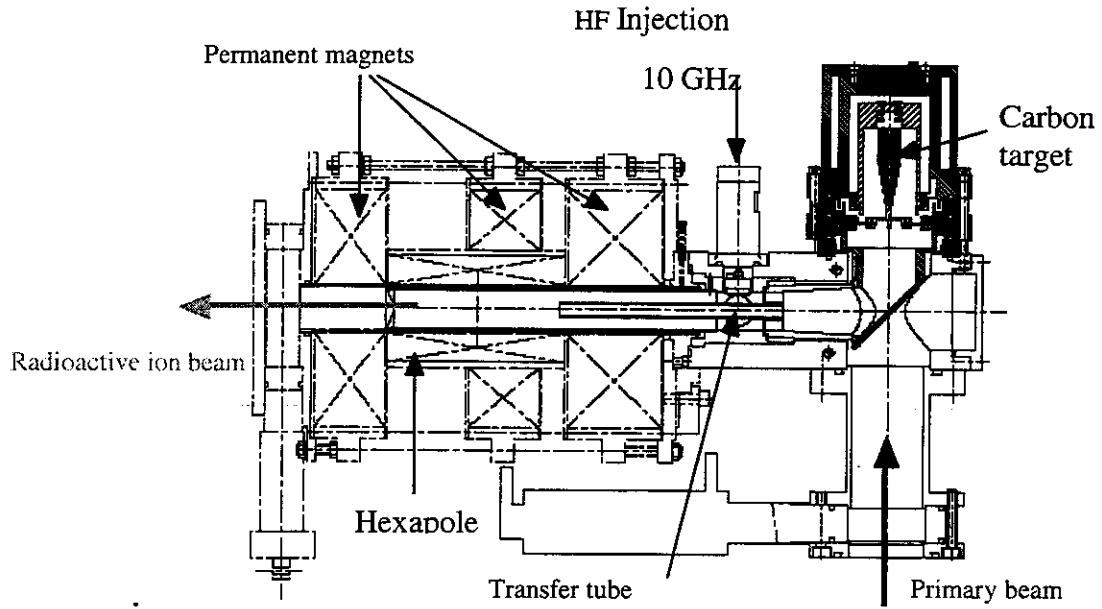

. **Figure 1: The nanogan3 configuration: a permanent magnet ECRIS is coupled to a graphite target through a cold transfer tube**

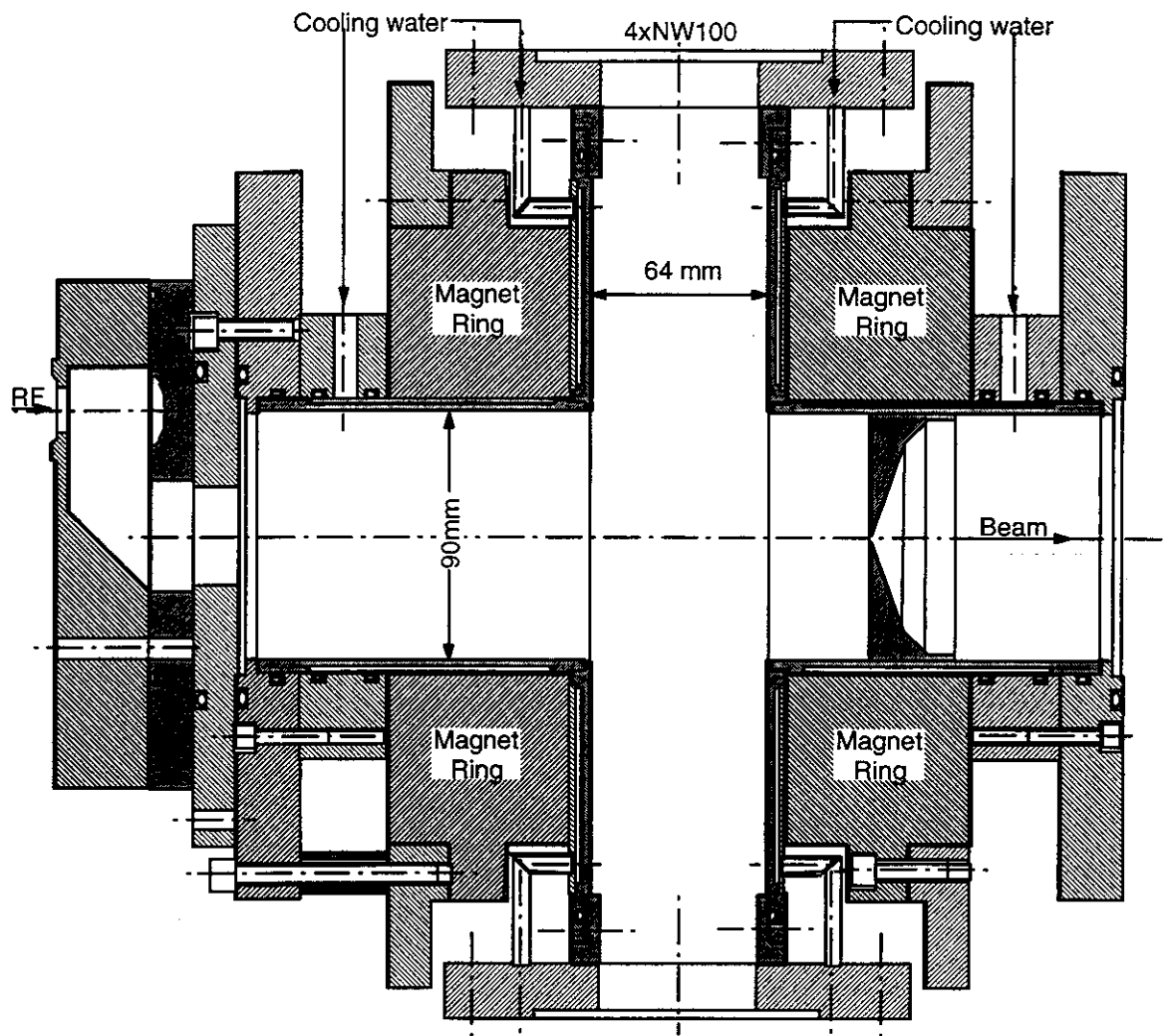

Figure 2: schematic drawing of the mono1001. A target can be mounted on one of the 64 mm inner diameter flange.

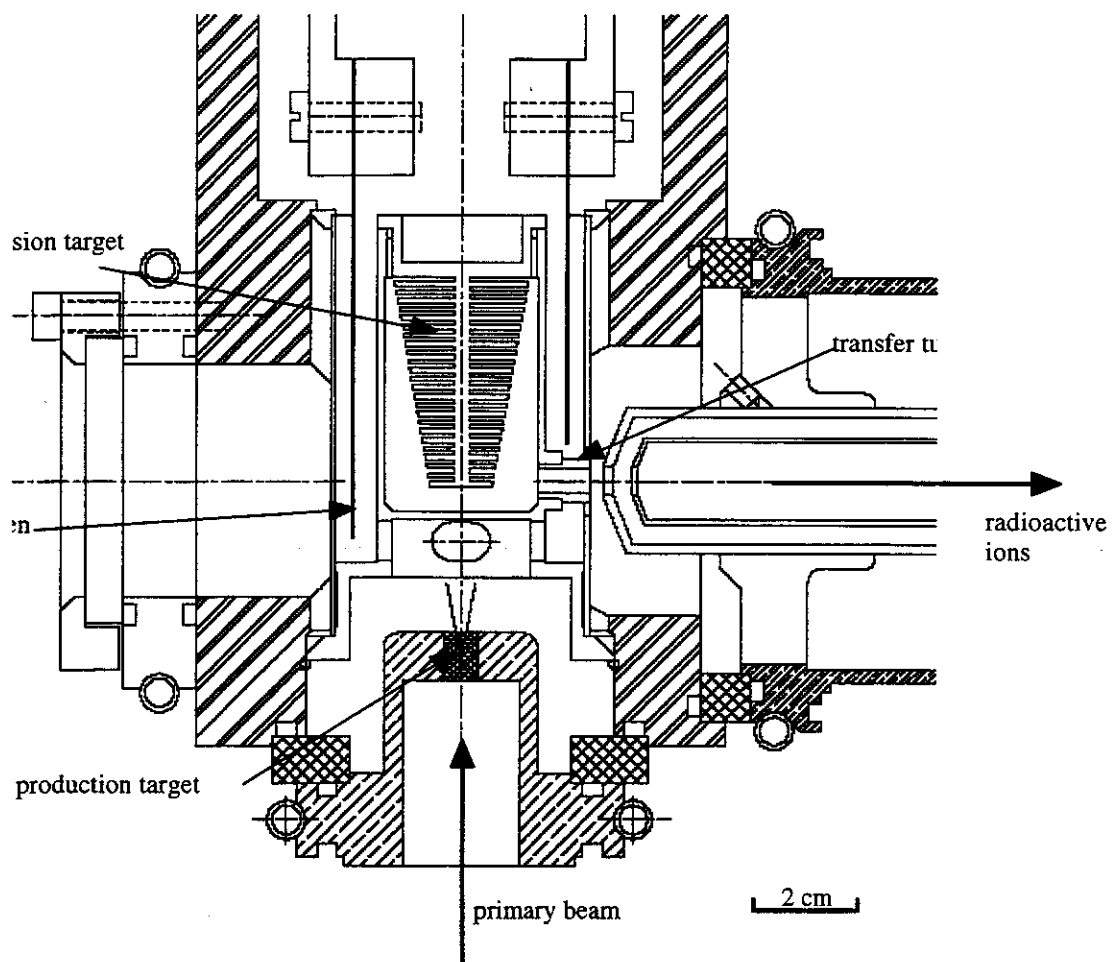

Figure 3: The monolithic configuration where the transfer tube is the surface ionizer