

CERN LIBRARIES, GENEVA



SCAN-9901086

E9-98-258

5wggc4

S.I.Kukarnikov, V.K.Makoveev, V.Ph.Minashkin,
A.Yu.Molodozhentsev, V.Ph.Shevtsov, G.I.Sidorov

DESIGN OF THE DIPOLE
AND QUADRUPOLE MAGNETS
OF THE DEDICATED PROTON SYNCHROTRON
FOR HADRON THERAPY

1998

© Объединенный институт ядерных исследований. Дубна, 1998

Introduction

A good clinical experience with proton-beam radiotherapy has stimulated the interest in designing and constructing dedicated hospital-based machines for this purpose. Reliability and simplicity without losing the required parameters of the machine should be considered, first of all, to design this accelerator. The technological and economic requirements for these machines are of great importance for an industrial approach. A synchrotron meets the machine requirements better than a linear accelerator or a cyclotron [1].

To meet the medical requirements [2], an active scanning should be fixed as a base of the designed machine. There are two strategies of active magnetic beam scanning - the raster and pixel scan. Both techniques are based on the virtual dissection of the tumour in slices of equidistant ranges. The modified raster-scan technique is proposed at GSI to treat cancer. This method is based upon an active energy- and intensity-variation within the treatment time and is a hybrid technique combining different features of both pixel and raster scan techniques [3].

The active scanning of tumours requires the 'long' extraction spill about 400 ms that can be obtained by the slow resonance extraction of the accelerated particles. In this case the magnetic elements of the synchrotron should have enough big radial dimension to provide the horizontal extraction without particle losses. Moreover, in the case of the third order extraction it is important to minimize high-order magnetic field components especially on high energy.

A focusing system of an accelerator is required to confine the beam, to keep its small transversal dimensions and, consequently, to reduce the vacuum chamber cross section and the magnetic gap. To solve all these problems, the successful approach is connected with a separate function magnetic system, which consists of dipole magnets with zero gradient of the magnetic field and quadrupole lenses with opposite focusing properties. A conventional copper-conductor room-temperature magnet option has been considered for the accelerator. Saturation in the iron yoke limits this type of magnet to fields of about 2 Tesla and quadrupoles are typically limited to gradients of about 20 Tesla/meter.

In this type of the dipole magnet, the shape of the iron pole is much more important than the position of the coil conductors for determining the field quality. The ideal pole profile is given by the equipotential curves defined by the scalar

potential function. In practice, the magnetic poles should be optimised both transversally and longitudinally. Since non-uniform saturation effects may happen in the iron, the detailed design can become very complicated. In order to limit these effects, the maximum magnetic field in the bending magnets should be not more than 1.6 Tesla.

The paper presents 2D-optimization results of the dipole and quadrupole magnets of the dedicated synchrotron for hadron therapy to obtain the required quality of the magnetic field in the 'working region' of the synchrotron chamber. The main design and electrical parameters of the elements are calculated. This report is limited to the static regime and the time stability requirements are omitted.

General features of the ring magnets

The focusing structure of the dedicated proton synchrotron consists of 8 dipole and 18 quadrupole magnets [4]. For the medical applications the output kinetic energy of the proton beam should be variable in the range of 60-220 MeV with the energy step of 0.4 MeV and the energy variability accuracy about ± 40 keV. The repetition rate of the accelerator is chosen of 1 Hz to get a spill time for slow extraction of about 500 ms.

The focusing structure is based on the rectangular 45 degree dipole magnets and the quadrupole lenses with the wide aperture. The maximum magnetic field of the dipole magnet is chosen of 1.2T to use only the linear part of the B(H) function. For the low-carbon steel the permeability curve is shown in **Fig.1**.

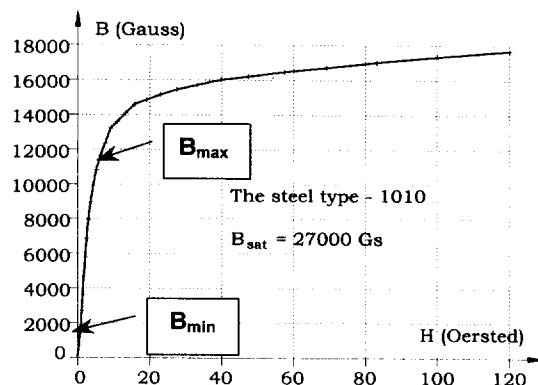

Figure 1: B versus H for the low-carbon steel (1010)

The injection energy is equal to 12 MeV, then the minimum magnetic field of the dipole magnet is equal to 0.2659T. The acceleration regime of the synchrotron is chosen to provide the maximum magnetic field ramp less than 8T/s. The maximum magnetic field on the pole of the quadrupole magnet should be less than 1 Tesla.

The 'good field' region of the synchrotron with the third-order resonance extraction in the horizontal plane is determined to correspond the injection and extraction conditions. This region includes the beam size and the allowed closed orbit distortion ± 10 mm. Then the 'working region' corresponding to the injection beam parameters is equal to 54 mm and 53 mm in the horizontal and vertical planes, respectively. The 'working region' corresponding to the slow extraction is equal to 126 and 54 mm in the horizontal and vertical planes, respectively.

To avoid beam losses at the entry to the extraction septa, it is necessary that the dipole fields are sufficiently uniform to maintain an orbit precision and reproducibility over the whole range from low to high field. It especially difficult to fulfil since these criteria on the aperture edge where the effects of saturation in the magnet are most evident and the largest field variations are inevitable. The magnetic field uniformity should be less than $\pm 1 \times 10^{-4}$ for the magnetic field values from 0.2659 till 1.2 T. For this value of the magnetic field uniformity the rms closed orbit distortion is less than ± 1 mm, that allows to minimize the particle losses in the electrostatic septa.

The quality of the magnetic field gradient of the quadrupole lenses is chosen to limit the deviation of the betatron frequency. The allowed value of the maximum deviation of the betatron frequency during extraction is equal to $\pm 5 \times 10^{-4}$. In this case the uniformity of the magnetic field gradient in the 'working region' to provide the slow extraction should be equal to $\pm 3.5 \times 10^{-4}$.

Optimization of the magnetic elements

Calculations are performed to get the optimum pole shapes and the main technical parameters of the dipole and quadrupole magnets meeting the field quality requirements. To solve this task, the POISSON-2D program [4] is used with the

permeability curve (Fig.1). The optimization of the magnetic elements has been prepared according to the following flow chart (Fig.2). To develop magnetic elements, it is necessary, first of all, to know dimensions of the aperture and working region, values of the magnetic field in gap and magnetic rigidity. After this one can calculate the maximum current in coils to get the required value of the magnetic field in the center of the working region. Using an optimal value of the current density in the coil ($\sim 4 \text{ A/mm}^2$), one can determine the coil area, geometry and number of Amper-turns. Then, magnet geometry and pole shapes are optimized to get the required magnetic field uniformity. We have performed calculations of the dipole magnet for 3 values of the field for different energies: for the injection energy - $B_0=0.2659 \text{ T}$; for the minimum extraction energy of 60 MeV - $B_0 = 0.602 \text{ T}$, and for the maximum extraction energy of 220 MeV - $B_0 = 1.2 \text{ T}$. Several iterations allow to reach the needed magnetic field quality in the 'working region'.

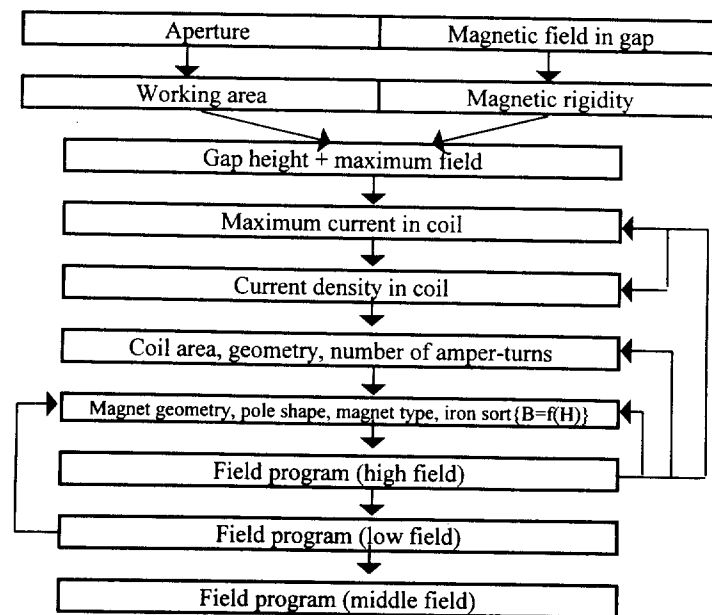

Figure 2: Flow chart for magnet design

Optimization of the dipole magnet

All magnets are laminated to minimize eddy currents. The dipoles are parallel-edge, the 'curved' H-type magnets. This design provides simple manufacturing and is a good compromise between the request for small size and weight, on the one hand, and high requirements to field uniformity ($\pm 1 \times 10^{-4}$) in the working area, on the other hand. As it is mentioned above, the 'good field' region on the injection energy is equal to ± 27 mm and ± 26.5 mm in the horizontal and vertical planes, respectively. The 'good field' region on the output energy of 60-220 MeV is equal to ± 63 mm and ± 21 mm in the horizontal and vertical planes, respectively. The horizontal size is determined by the third-order. The vertical one - by the vertical beam size on the minimum extraction energy (60 MeV). The 'good field' regions on different energies are shown in Fig.3.

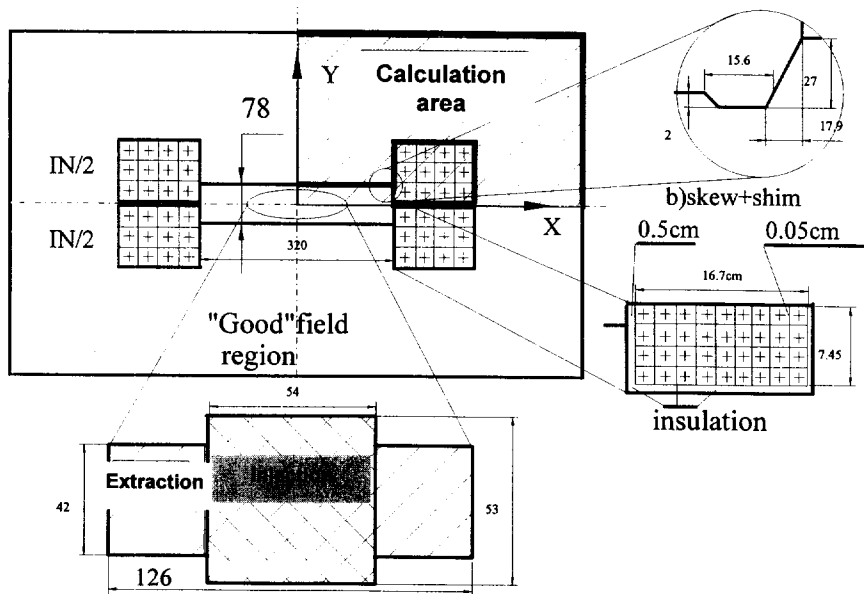

Figure 3: General layout of the dipole magnet cross section.

The cross section of the H-type dipole magnet is presented in **Fig.3** with the main dimensions of the 'good field' region at different energies, the coil geometry, and the optimized pole shape. The calculation model of the H-type magnet with the fluxlines in case of the 1.2 T magnetic field is shown in **Fig.4**. The main geometrical dimensions and the vacuum chamber cross section are indicated in this figure. The height of the magnet is equal to 50 cm. The width is equal to 98.4 cm. The yoke dimensions are chosen to avoid the saturation effects and to minimize the weight of the magnet.

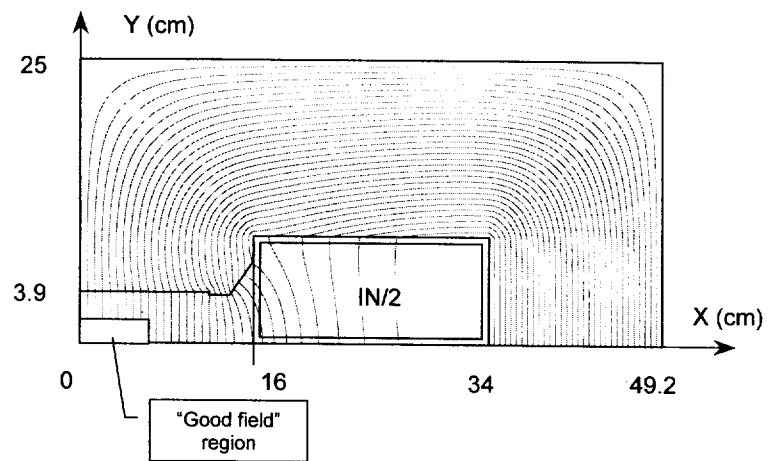

Figure 4: The calculation model of the H-type magnet

The main parameters of the dipole magnet used for the calculations are collected in **Table 1**.

Table 1

Main parameters of the dipole magnet

Dipole magnet gap	cm	7.8
'Good field' region (h / v) injection extraction	cm	5.4 / 5.3 12.6 / 4.2
Magnetic field uniformity		$< \pm 1 \times 10^{-4}$
Dipole magnetic field injection (12MeV) extraction (60/220MeV)	T	0.2659 0.602 / 1.2
Coil current (IN/2) injection extraction (60/220MeV)	kA × turns	8.5 18.7 / 38.2
Maximum current density in coil	A/mm ²	4.323
Coil parameters:		
Conductor size	mm ²	18 × 18 with hole 10 mm
Total cross section	mm ²	324
Cu - cross section	mm ²	245.5
filling factor		0.7
optimum form		rectangle 2:1
Number of turns per coil		9 × 4 = 36

The calculation results of the dipole magnet optimization are shown in **Fig.5**. The magnetic field uniformity (dB/B_0) of the dipole magnet in the working area for all values of B_0 corresponding to different energies meets the requirements determined above. The field uniformity along the pole on different y-coordinates ($y=0; 0.675; 1.35; 2.025; 2.7\text{cm}$) in the 'good field' region are given in the figure. The harmonic analysis of the magnetic field shows that the sextupole component of the field is less than 10^{-4} in the center of the gap. To optimize the magnet edges, it is necessary to perform 3D calculations based on the obtained results.

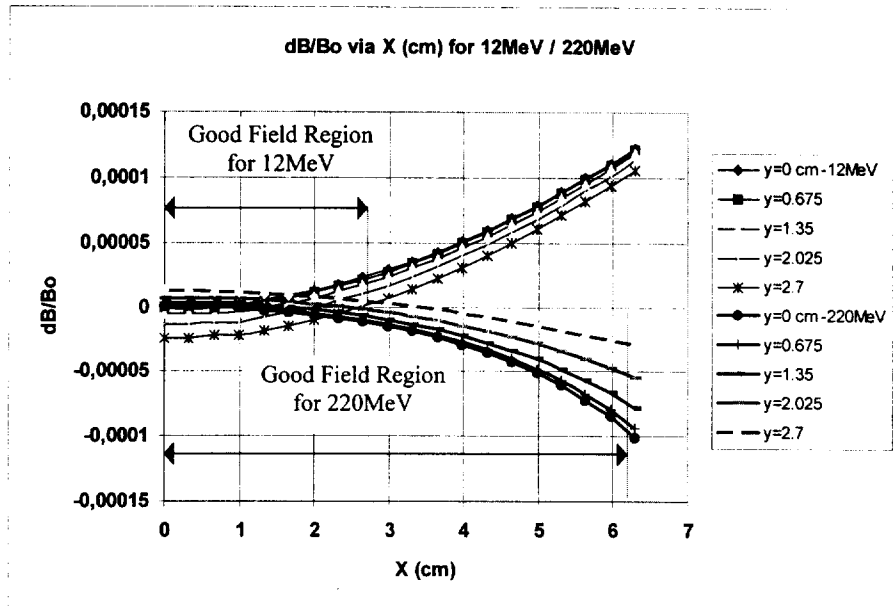

Figure 5: Magnetic field uniformity in the gap of the dipole magnet for minimum and maximum particle energies.

Construction and main parameters of the dipole magnet

The basic dimensions (width \times height \times length) are equal to $984 \times 499 \times 1381.2 \text{ mm}^3$. The curvature radius of the central axis of the dipole magnet is equal to 1.888m. To minimize the size, the magnet has been designed as a curved H-type dipole. The maximum ramp of the magnetic field is equal to 6.5T/s, which requires the magnet to be laminated. The magnet is assembled from two half-cores bolted together. The shims of the magnet edges should be used for the quality of the magnetic field ($\pm 1 \times 10^{-4}$) in the working area ($126 \times 54 \text{ mm}^2$). To correct the effective length of the magnets, the withdrawable plates should be utilized on the magnet edges. The additional current winding should be used to provide accurate regulation (about 1% of the base current).

The technical design of the magnet is shown in **Fig.6**. The main technical parameters of the dipole magnet are estimated and collected in **Table 2**.

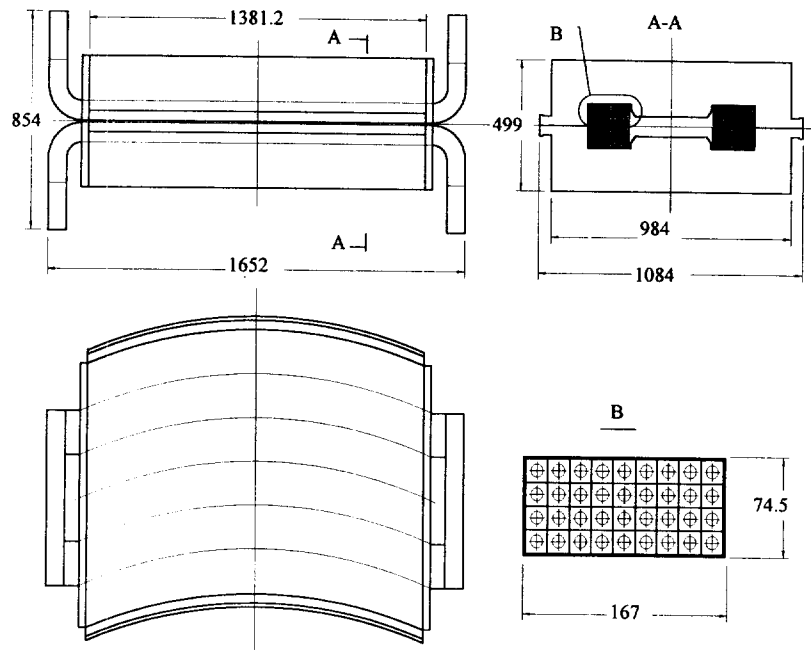

Figure 6: Technical design of the dipole magnet

Table 2

Main technical parameters of the dipole magnets

Type of the magnets		'curved' H-type
Magnetic effective length	m	1.4826
Number of magnets		8
Edge focusing		rectangular
Magnetic field at injection	T	0.2659
Min. magnetic field at extraction	T	0.602
Max. magnetic field at extraction	T	1.2
Max. magnetic field ramp rate	T/s	6.5
Gap height	mm	78
Pole width	mm	320
Working region [h / v]	mm	126 / 54
Magnetic field uniformity in working region		$< \pm 1 \times 10^{-4}$
Bending angle	degree	45
Magnet width	mm	984
Magnet height	mm	499
Magnet length	mm	1381.2
Conductor size	mm×mm	18×18
Cooling hole diameter	mm	10
Effective Copper area	mm ²	245.46
Average coil length per turn	m	5.025
Filling factor		0.71
Number of turns per coil		36
Number of coils per magnet		2
Current at injection	A	236
Maximum current at extraction	A	1061
Maximum current density	A/mm ²	4.32
Resistance total (8 magnets)	mΩ	197.28
Inductance total (8 magnets)	mH	355.6

Optimization of the wide aperture quadrupole magnet

The quadrupole magnet has been calculated like dipole magnets using the POISSON program. The calculation model of the quadrupole magnet with the fluxlines is shown in **Fig.7**. The aperture radius of the quadrupole lens is equal to 65mm. In this case to get the required ($\pm 3.5 \times 10^{-4}$) uniformity of the magnetic field gradient in the 'good field' region, the pole width of the lens should be about 150mm.

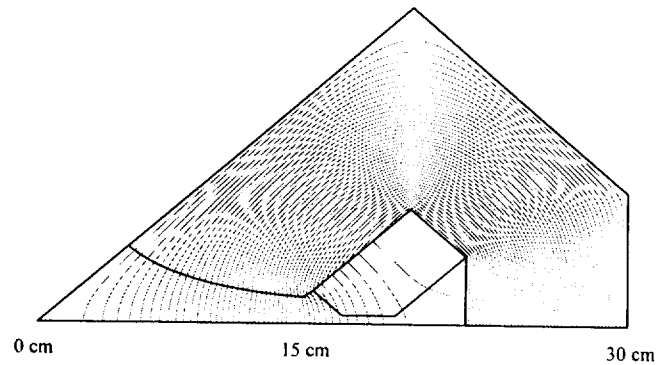

Figure 7: Model of the quadrupole magnet with fluxlines.

The results of these calculations are shown in **Fig.8**. As one can see, the gradient uniformity of quadrupole magnets in the working area ($126 \times 54 \text{mm}^2$) meets the requirements to this magnet for all energies from 12 MeV till 220 MeV.

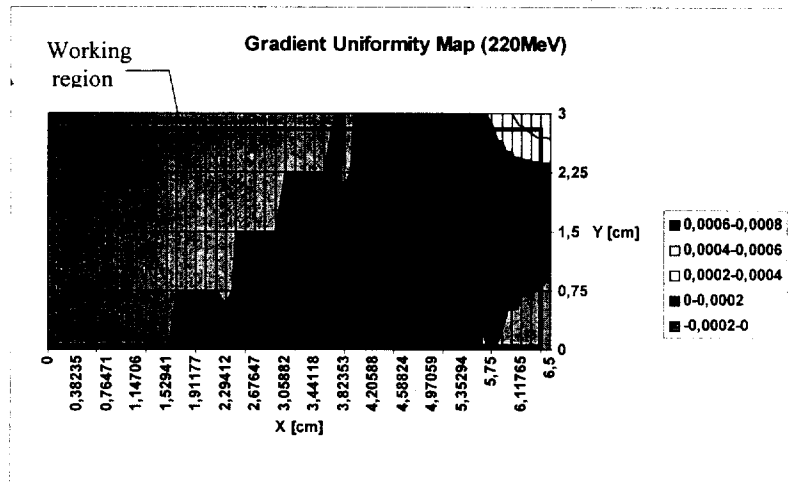

Figure 8: Gradient uniformity of quadrupole magnets for the energy of 220MeV.

Construction and main parameters of the quadrupole magnet

The general view of the quadrupole magnet is presented in **Fig.9**. The main technical parameters of the dipole magnet are estimated and collected in **Table 3**.

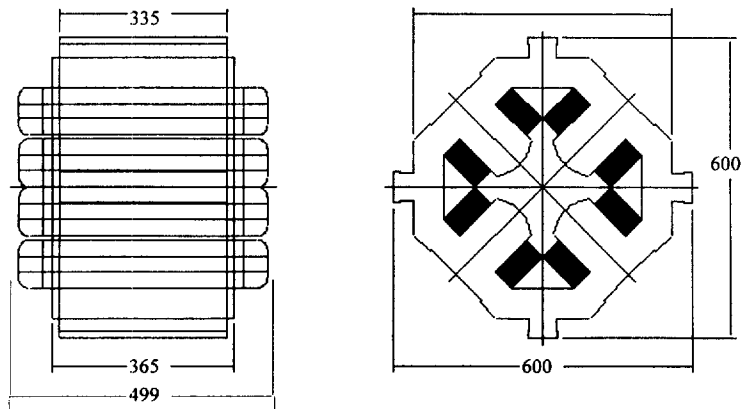

Figure 9: General layout of the quadrupole magnet

Table 3
Main technical parameters of quadrupole magnet

Effective length	mm	400
Aperture radius	mm	65
Yoke length	mm	335
Maximum strength	m ⁻²	3.3927
Maximum pole magnet field (E=220MeV)	T	0.499
Minimum pole magnet field (E=12MeV)	T	0.111
Maximum field gradient (E=220MeV)	Gs/cm	768
Minimum field gradient (E=12MeV)	Gs/cm	170.2
Relative gradient uniformity		$\pm 3.5 \times 10^{-4}$
Maximum current*turns (E=220MeV)	kA × turns	12.910
Minimum current*turns (E=12MeV)	kA × turns	2.862
Maximum current (E=220MeV)	A	403.5
Minimum current (E=12MeV)	A	89.5
Conductor size	mm ²	10.5×10.5
Cooling hole diameter	mm	6
Number of turns per coil		32
Number of coils per magnet		4
Resistance per magnet	mΩ	37
Inductance per magnet	mH	22.6

Conclusion

The 2D-calculations of the main magnetic elements of the dedicated proton synchrotron for hadron therapy have been performed to reach the required field quality. The main technical parameters of the rectangular dipole magnets and the quadrupole lenses have been determined. The preliminary design of the magnetic elements is discussed. To optimize the edge field of the magnets, it is necessary to carry out the 3D-calculations of the elements.

References:

- [1] U.Amaldi, M.Grandolfo and L.Picardi Editors: The TERA project and the design of compact proton accelerators (The TERA Collaboration), 1995.
- [2] H.Eickhoff et al., Accelerator Aspects of the Cancer Therapy Project at the GSI Darmstadt, in Proc. of the EPAC96 Conference, London, 1996.
- [3] Th.Habere et al., Magnetic scanning system for heavy ion therapy, NIM A330 (1993) 296-305.
- [4] A.Molodozhentsev, V.Makoveev, I. Ivanov, G.Sidorov, K.Prokesh, J.Sedlak, M.Kuzmiak, The Focusing Structure of the Prague Proton Synchrotron for Hadron Therapy, in Proc. of the PAC'97 Conference, May 1997, Vancouver, Canada.
- [5] User's guide for the POISSON/SUPERFISH group of codes, LA-UR-87-115.

Received by Publishing Department
on September 18, 1998.

**Издательский отдел
Объединенного института ядерных исследований
предлагает Вам приобрести перечисленные ниже книги:**

Индекс книги	Название книги
94-55	Боголюбовские чтения. Материалы Международного совещания. Дубна, 1993 г. 216 с. (на русском и англ. яз.) Книга В.С.Барашенкова «Сечения взаимодействия частиц и ядер с ядрами». 1993 г. 346 с.
ДЗ,14-95-323	Труды VII школы по нейтронной физике. Дубна, 1995, том I, 356 с. (на русском и англ. яз.)
E10,11-95-387	Труды Международной конференции REAL TIME DATA'94. Дубна, 1994, 358 с. (на англ. яз.)
Д15-96-18	Труды рабочего совещания «Зарядовые и нуклонные радиусы экзотических ядер». Познань, 1995, 172 с. (на русском и англ. яз.)
E9-96-21	Труды рабочего совещания секции ICFA динамики пучков «По эффектам встречи в кольцевых коллайдерах». Дубна, 1995, 198 с. (на англ.яз.)
E2-96-100	Труды 3 международного симпозиума «Дейтрон — Дубна-95». Дубна, 1995, 374 с. (на англ. яз.)
E2-96-224	Труды VII международной конференции «Методы симметрии в физике». Дубна, 1996, 2 тома, 630 с. (на англ. яз.)
E10-96-258	Труды 17 ежегодного совещания группы пользователей TEX. Дубна, 1996, 170 с. (на англ. яз.)
E-96-321	Труды международного семинара «Интегралы по траекториям: Дубна-96». Дубна, 1996, 392 с. (на англ. яз.)
E2-96-334	Труды Российско-немецкого совещания по физике тяжелых кварков. Дубна, 1996, 240 с. (на англ. яз.)
E3-96-336	Труды 4 Международного семинара по взаимодействию нейтронов с ядрами. Дубна, 1996, 396 с. (на англ. яз.)
E3-96-369	Труды X международной конференции «Проблемы квантовой теории поля». Дубна, 1996, 437 с. (на англ. яз.)
E3-96-507	Труды международного семинара «Поляризованные нейтроны в исследованиях конденсированных сред». Дубна, 1996, 154 с. (на англ. яз.) Книга А.Н.Боголюбова. Н.Н.Боголюбов. Жизнь. Творчество. Дубна, 1996; 182 с. (на русском яз.)
Д1,2-97-6	Труды международного семинара «Релятивистская ядерная физика от сотен МэВ до ТэВ». Дубна, 1996, 2 тома, 418 с. и 412 с. (на русском и англ. яз.)
E7-97-49	Труды 3 международной конференции и «Динамические аспекты деления ядер». Словакия, 1996, 426 с. (на англ. яз.)

Индекс книги	Название книги
E1,2-97-79	Труды XII Международного семинара по проблемам физики высоких энергий. Релятивистская ядерная физика и квантовая хромодинамика. Дубна, 1994, 2 тома, 364 с. и 370 с. (на англ. яз.)
Д5,11-97-112	Труды IX международной конференции «Математическое моделирование в физике». Дубна, 1996, 378 с. (на русском и англ. яз.)
E3-97-213	Труды V Международного семинара по взаимодействию нейтронов с ядрами. Дубна, 1997, 446 с. (на англ. яз.)
Д9-97-231	Труды международной школы молодых ученых «Проблемы ускорения заряженных частиц». Дубна, 1996, 285 с. (на русском и англ. яз.)
E2,4-97-263	Труды III международной конференции «Ренормгруппа-96». Дубна, 1996, 436 с. (на англ. яз.)
E10-97-272	Труды международного рабочего совещания «Системы сбора данных в экспериментах на нейтронных источниках». Дубна, 1997, 325 с. (на англ. яз.)
Д19-97-284	Труды международного симпозиума «Проблемы биохимии, радиационной и космической биологии». Дубна, 1997, 2 тома: 284 и 405 стр. (на русском и англ. яз.)
P14-97-343	Труды Национальной конференции по применению рентгеновского синхротронного излучения нейтронов и электронов для исследования материалов. Дубна, 1997, 3 тома, 370 с., 448 с., 340 с. (на русском яз.)
Д -97-376	Труды I открытой конференции молодых ученых и специалистов ОИЯИ. Дубна, 1997, 254 с. (на русском яз.)
E2-97-413	Труды VII Международного совещания по спиновой физике высоких энергий (СПИН-97). Дубна, 1997, 398 с. (на англ. яз.)

За дополнительной информацией просим обращаться в издательский отдел ОИЯИ по адресу:

141980, г.Дубна, Московской области,
ул.Жолио-Кюри, 6.
Объединенный институт ядерных исследований,
издательский отдел
E-mail: publish@pds.jinr.dubna.su

Кукарников С.И. и др.

E9-98-258

Разработка дипольных и квадрупольных магнитов специализированного протонного синхротрона для радиотерапии

Представлены результаты 2-мерных расчетов магнитного поля элементов пражского медицинского синхротрона (ПРАМЕС). Эта машина предназначена для терапии раковых заболеваний. Выходная энергия пучка может изменяться в диапазоне 60–220 МэВ. Максимальное магнитное поле в дипольных магнитах 1,2 Тл, максимальная скорость изменения магнитного поля — менее 8 Тл/с. Фокусирующая структура протонного синхротрона состоит из 8 дипольных и 18 квадрупольных магнитов. Все магниты имеют слоистую структуру для минимизации токов утечки. Все дипольные магниты имеют структуру типа *H* с параллельными торцами. Неоднородность магнитного поля порядка $\pm 1 \times 10^{-4}$ в рабочей области (± 63 мм и ± 27 мм в горизонтальном и вертикальном плане, соответственно). Максимальное магнитное поле на полюсе квадрупольной линзы менее 1 Тл. Неоднородность градиента магнитного поля в квадрупольных магнитах менее $\pm 3,5 \times 10^{-4}$.

Работа выполнена в Лаборатории сверхвысоких энергий ОИЯИ.

Сообщение Объединенного института ядерных исследований. Дубна, 1998

Kukarnikov S.I. et al.

E9-98-258

Design of the Dipole and Quadrupole Magnets of the Dedicated Proton Synchrotron for Hadron Therapy

The 2D-calculation results of magnetic elements of the PRAMES (Prague Medical Synchrotron) are presented. This machine is a dedicated accelerator for cancer therapy. The output energy of the beam should be variable in the range 60–220 MeV. The maximum magnetic field of the dipole magnet should be 1.2 T, the maximum magnetic field ramp — less than 8 T/s. The focusing structure of the proton synchrotron consists of 8 dipole and 18 quadrupole magnets. All magnets are laminated to minimize addy currents. The dipoles are parallel-edge, *H*-type magnets. The field uniformity should be of the order of $\pm 1 \times 10^{-4}$ in the working area (± 63 mm and ± 27 mm in the horizontal and vertical planes, respectively). The maximum magnetic field on the pole of the quadrupole lenses should be less than 1 T. The gradient uniformity of quadrupole magnets in the working region should be less than $\pm 3.5 \times 10^{-4}$.

The investigation has been performed at the Laboratory of Particle Physics, JINR.

Communication of the Joint Institute for Nuclear Research. Dubna, 1998

Макет Т.Е.Попеко

Подписано в печать 21.10.98
Формат 60 × 90/16. Офсетная печать. Уч.-изд. листов 1,8
Тираж 300. Заказ 50960. Цена 2 р. 16 к.

Издательский отдел Объединенного института ядерных исследований
Дубна Московской области
