

DD

ISTITUTO NAZIONALE DI FISICA NUCLEARE

Sezione di Catania

INEN/TC-97/27
25 Settembre 1997

D. Nicotra, G. Saccà, N. Guardone, M. D'Andrea, F. Fichera:
**HEAT DISSIPATION IN THE "CHIMERA" FIRST WHEEL PREAMPLIFIERS
SETUP**



SW 97 51

HEAT DISSIPATION IN THE “CHIMERA” FIRST WHEEL PREAMPLIFIERS SETUP

D. Nicotra*, G. Saccà*, N. Guardone**, M. D’Andrea*, F. Fichera*

* *Istituto Nazionale di Fisica Nucleare, Sezione di Catania, Corso Italia 57, 95129 Catania, Italy*

** *Dipartimento di Fisica dell’Università di Catania, Corso Italia 57, 95129 Catania, Italy*

Abstract

Calculations of the heat dissipation and measurements of the temperatures in a prototype of the first wheel electronics of the multidetector “CHIMERA” have been performed. The aim of these tests has been the optimization of the thermal coupling between the different electronic components of the setup.

1. INTRODUCTION

Among the possible causes of instability in detector-preamplifier chains, the thermic stress plays an important role which must be taken into account in the project of the device. In the case we are considering (see fig. 1) the system to be studied is composed of the environment, the motherboards, the mechanical support (the wheel) and the cooling channel. Because of the system will operate in a vacuum chamber we can neglect the convection and the radiation contributions to the heat transfer in the set up.

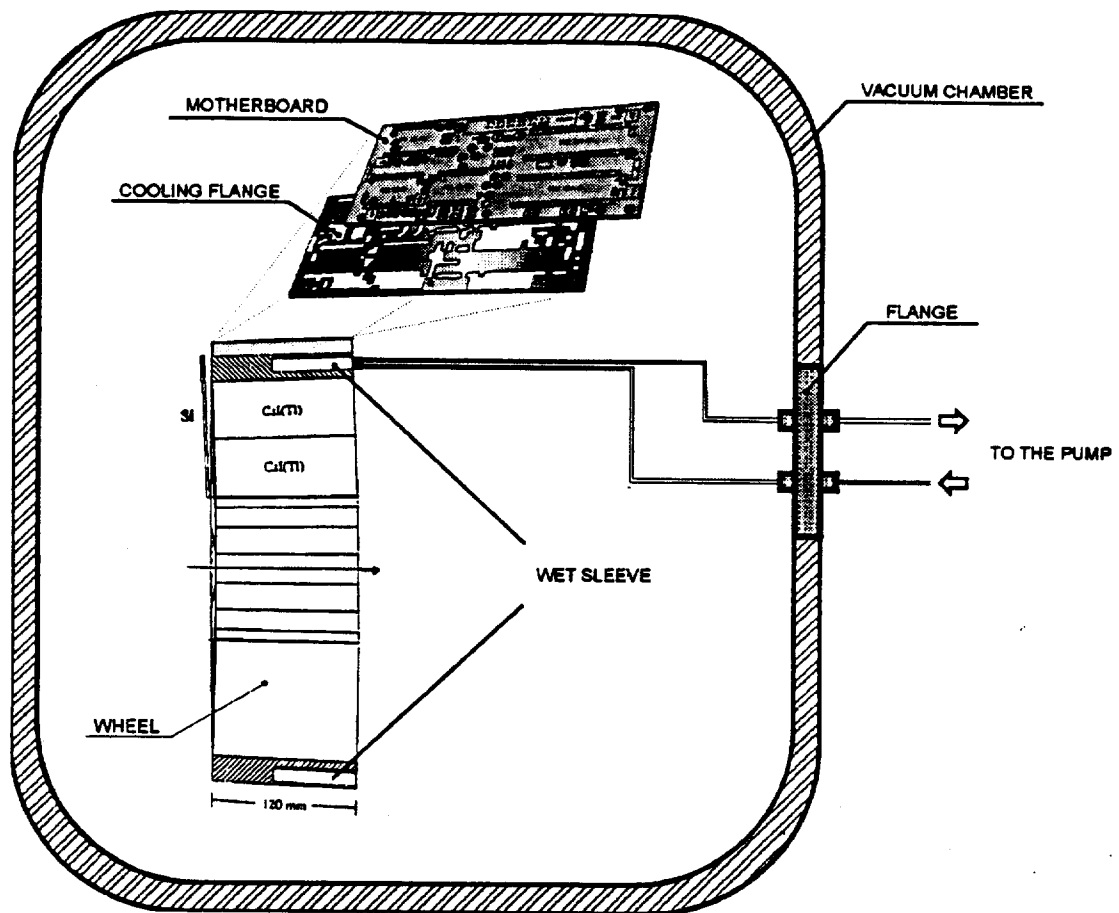

Figure 1 : General assembly scheme of the system under test.

The multidetector CHIMERA⁽¹⁾ will be composed of 1192 preamplification modules which must be kept at very low temperature in such a way the required performances can be obtained. Therefore what we need is to have the maximum thermal conductivity in the coupling of the different elements of the system.

2. THE MOTHERBOARD HEAT FLOW

The figure 2 shows the block diagram of the motherboard. If we neglect the dissipation of the passive component (low pass filter), the most of the heat flow generated by the motherboard is due to the power dissipated in the preamplifiers, while the rest is dissipated in the overload protection devices.

(1) CHIMERA is a 4π multidetector for heavy-ion physics. Si and CsI (TI) detectors are used for the $\Delta E-E$, Time of Flight identification techniques and pulse shaping. See S. Aiello et al. *Nucl. Phys. A583 (1995) 461-464*.

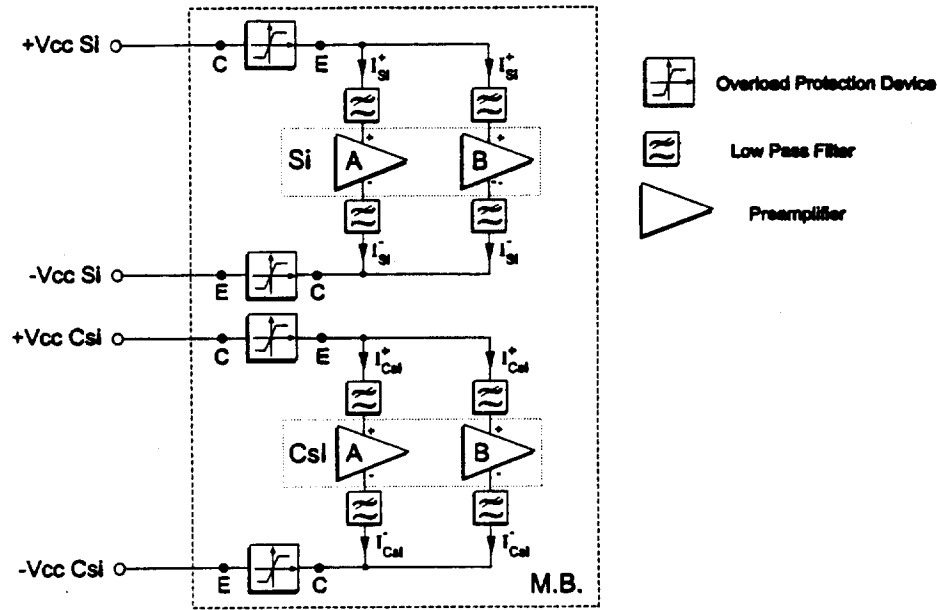

Figure 2 : Motherboard block diagram.

In Table 1 we report the current and voltage power lines values of the motherboard. These values have been used for the evaluation of the power dissipated in the preamplifiers⁽²⁾ which determine the heat flow in the motherboard.

Table 1 : Measured currents and voltages values of a motherboard.

Preamplifier Si detectors		Preamplifier CsI detectors	
Current (mA)	Voltage (V)	Current (mA)	Voltage (V)
$I_{Si}^+ = 14.4$	$V_{Si}^+ = +6.5$	$I_{CsI}^+ = 6.2$	$V_{CsI}^+ = +12$
$I_{Si}^- = 7.5$	$V_{Si}^- = -12$	$I_{CsI}^- = 6.9$	$V_{CsI}^- = -12$

The power dissipated (P_d) in a motherboard (with two preamplifiers for Si detectors and two preamplifiers for CsI detectors) is given by :

$$P_d = P_{pa} + P_{opd} \tag{1}$$

(2) - Preamplifiers for Silicon detectors developed by Service Electronique Nucleaire Saclay (FR)

- Preamplifiers for CsI(Tl) detectors developed by Servizio elettronica I.N.F.N. Sez.Milano (I).

where P_{pa} is the power dissipated by the preamplifiers and P_{opd} is the power dissipated by the overload protection devices.

By using the values of the currents and the voltages reported in Table 1, one can evaluate P_{pa} by :

$$P_{pa} = 2 \cdot (P_{Si} + P_{CsI}) \quad (2)$$

where P_{Si} and P_{CsI} are the power dissipated by a Si preamplifier and by a CsI preamplifier respectively. P_{Si} and P_{CsI} are given by :

$$P_{Si} = (V_{Si}^+ \cdot I_{Si}^+) + (V_{Si}^- \cdot I_{Si}^-) = (6.5 \cdot 14.4 \cdot 10^{-3}) + (12 \cdot 7.5 \cdot 10^{-3}) = (93.6 + 90) \cdot 10^{-3} \cong 183.6 mW \quad (3)$$

$$P_{CsI} = (V_{CsI}^+ \cdot I_{CsI}^+) + (V_{CsI}^- \cdot I_{CsI}^-) = (12 \cdot 6.2 \cdot 10^{-3}) + (12 \cdot 6.9 \cdot 10^{-3}) = (74.4 + 82.8) \cdot 10^{-3} \cong 157.2 mW \quad (4)$$

Therefore, by inserting the values (3) and (4) in formula (2), we obtain :

$$P_{pa} = 2 \cdot (183.6 + 157.2) \cdot 10^{-3} \cong 680 mW$$

P_{opd} is given by:

$$P_{opd} = (I_{Si}^+ + I_{Si}^- + I_{CsI}^+ + I_{CsI}^-) \cdot V_{CE} = [(28.7 + 15 + 12.5 + 13.7) \cdot 10^{-3}] \cdot 1.4 \cong 90 mW \quad (5)$$

where V_{CE} is the potential difference between the points C and E (see fig. 2). By inserting the values of P_{pa} and P_{opd} in (1) we have $P_d = 770 mW$.

Finally the heat flow generated by a motherboard is $q_{M.B.} = P_d = 770 mW$, while those generated by a single preamplifier are $q_{Si} = P_{Si} \cong 183 mW$ for Si preamplifier and $q_{CsI} = P_{CsI} \cong 157 mW$ for CsI preamplifier.

3. TEMPERATURE MEASUREMENTS

We measured the temperature in a set of points inside the vacuum chamber where the first wheel of CHIMERA was housed, in two different cases: at atmospheric pressure and at a pressure of $\sim 10^{-2}$ atm.

At atmospheric pressure

- thermocouple (K type) inserted between a motherboard and the cooling flange (see fig. 3-a) ;
- 16 motherboards (32 amplifiers Si and 32 CsI) switched on ;
- cooling system switched off ;
- cylindrical vacuum chamber (diameter = 600 mm and length = 1000 mm) with closed hatch.

The initial environment temperature was 25 °C and after a three hours run it did not change. On the motherboard we measured an increase of 2 °C.

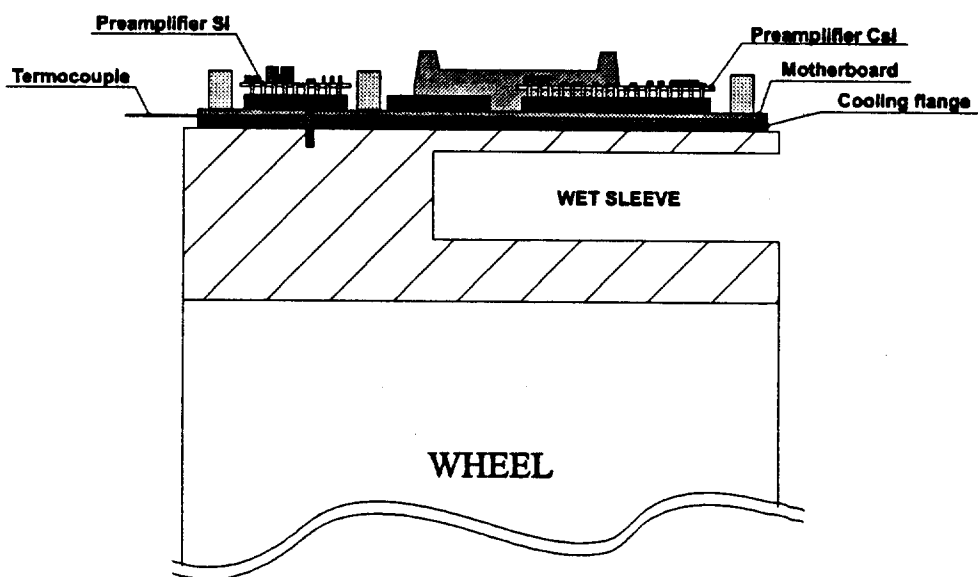

Figure 3-a : Setup for the measurement of the temperature of the motherboard $T_{M.B.}$.

Under vacuum

- sticker thermocouple put on the preamplifiers and between the motherboard and the cooling flange (see fig. 3-b) ;
- 16 motherboards (32 preamplifiers Si and 32 CsI) switched on
- cooling system switched on with an initial temperature of 18 °C and a programmed final temperature of 10 °C.

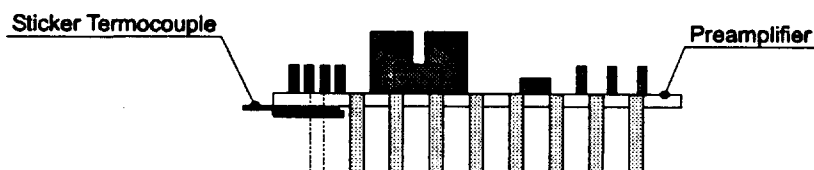

Figure 3-b : Setup for the measurement of the temperature T_{Si} and T_{CsI} of the Si and CsI preamplifiers respectively

In fig. 4 we report the behaviour of the temperature of the Si preamplifier (T_{Si}), of the CsI preamplifiers (T_{CsI}), of a motherboard ($T_{M.B.}$) and of the cooling fluid (T_{fluid}) measured at different time values during the run at a $3 \cdot 10^{-2}$ atm pressure.

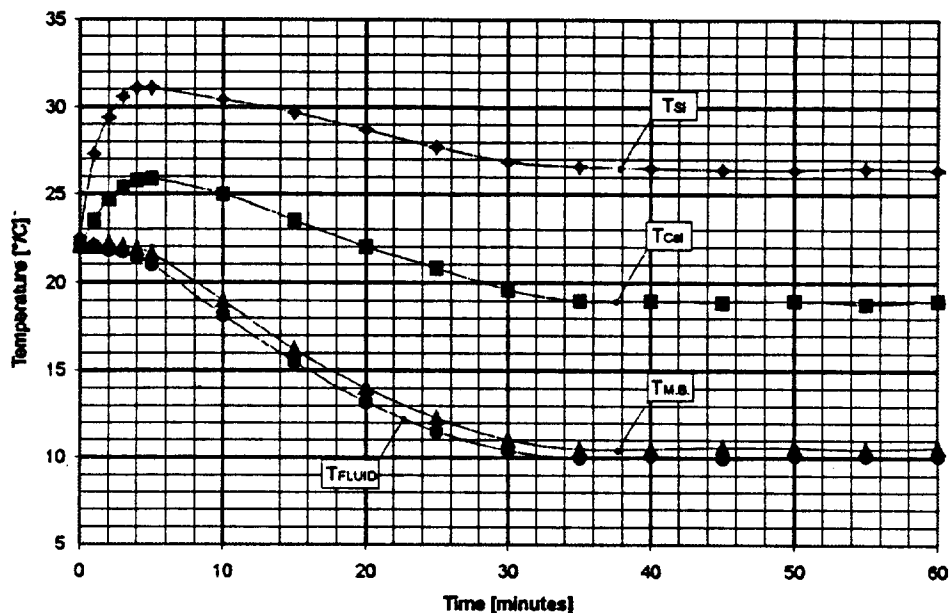

Figure 4 : Behaviour of the temperatures of Si and CsI preamplifiers (T_{Si} and T_{CsI}), of the motherboard ($T_{M.B.}$) and of the cooling fluid (T_{fluid}) during the run under vacuum. Solid lines are reported as eyes guide.

4. THE THERMAL RESISTANCE EVALUATION

The transfer of the heat from the preamplifiers to the motherboard and then to the cooling channel occurs exclusively through the pins of the preamplifiers. The thermal resistance⁽³⁾ which determines the efficiency of the cooling system is composed of two terms: $Rth_{pre-M.B.}^{Si,CsI}$ (relative to the coupling preamplifier-motherboard) and $Rth_{M.B.-cool}$ (relative to the coupling motherboard-cooling channel). We can observe in fig. 4 that after a 30 minutes transient, the regime temperatures values are 26.4 °C, 18.9 °C, 10.6 °C and 10.1 °C for the Si preamplifier, CsI preamplifier, the motherboard and the cooling fluid respectively. The relevant values of the heat flux can be evaluated from the voltage and current values reported in Table 1. Finally, the thermal resistances are given by :

(3) The thermal resistance $Rth_{x,y}$ between the points x and y is given by: $Rth_{x,y} = \frac{T_x - T_y}{q}$, where T_x and T_y are the temperatures at x and y and q is the heat flux.

$$Rth_{pre-M.B.}^{Si} = \frac{T_{Si} - T_{M.B.}}{q_{Si}} = \frac{26.4 - 10.6}{183 \cdot 10^{-3}} = 86 \left[\frac{^{\circ}C}{W} \right] \quad (6)$$

$$Rth_{pre-M.B.}^{CsI} = \frac{T_{CsI} - T_{M.B.}}{q_{CsI}} = \frac{18.9 - 10.6}{157 \cdot 10^{-3}} = 53 \left[\frac{^{\circ}C}{W} \right] \quad (7)$$

$$Rth_{M.B.-cool} = \frac{T_{M.B.} - T_{cool}}{q_{M.B.}} = \frac{10.6 - 10.1}{770 \cdot 10^{-3}} = 0.65 \left[\frac{^{\circ}C}{W} \right] \quad (8)$$

These values of the thermal resistances have been obtained by increasing the number of the ground pins of the preamplifier in such a way we improved the thermal coupling between the preamplifiers and the motherboard without modifying their performances. To have an idea of the effect of this technique we can compare the thermal resistance of the Si preamplifiers (5 ground pins) with the thermal resistance of the CsI preamplifiers (16 ground pins). The difference of 11 ground pins amount to a reduction of the thermal resistance by 38 %.

To minimize the thermal resistance of the motherboard-cooling channel coupling we put a cooling flange (fig. 1) between the motherboard and the wheel. The cooling flange has been made by reproducing the design of the drilling plane of the motherboard on a photoengraved and nickel plated sheet.

5. CONCLUSIONS

The calculations of the heat dissipation and the measurements of the regime temperatures of the electronic components of the CHIMERA first wheel suggest that an improvement of their thermal coupling by means a reduction of the thermal resistances can be easily performed by increasing the number of ground pins of the preamplifiers. The reduction of the difference between the thermal resistance of Si and CsI preamplifiers will be the next step of this study.

ACKNOWLEDGEMENT

The authors are very grateful to S. Urso for the continuous assistance during the tests. We wish to thank F. Librizzi and S. Reito for their technical support. We would like also to acknowledge Dott. A. Pagano for fundamental discussions and Dott. R. Fonte for many useful suggestions.

