

BB



WM-96-104
CEBAF-TH-96-07

The Continuous Electron Beam Accelerator Facility
Theory Group Preprint Series

Consistent relativistic treatment of the structure of the deuteron and its electromagnetic interactions

Franz Gross

*College of William and Mary, Williamsburg, VA 23185, USA
and
Continuous Electron Beam Accelerator Facility
12000 Jefferson Ave, Newport News, Virginia 23606, USA*



Abstract

Relativistic calculations of deuteron static properties, the triton binding energy, and deuteron form factors are presented. The results show that the covariant formalism is capable of replacing nonrelativistic quantum mechanics, at least for the description of two and three body systems, and that some significant new insights emerge when the dynamics is described relativistically.

Additional copies are available from the authors.

The Southeastern Universities Research Association (SURA) operates the Continuous Electron Beam Accelerator Facility for the United States Department of Energy under contract DE-AC05-84ER40150

DISCLAIMER

This report was prepared as an account of work sponsored by the United States government. Neither the United States nor the United States Department of Energy, nor any of their employees, makes any warranty, express or implied, or assumes any legal liability or responsibility for the accuracy, completeness, or usefulness of any information, apparatus, product, or process disclosed, or represents that its use would not infringe privately owned rights. Reference herein to any specific commercial product, process, or service by trade name, mark, manufacturer, or otherwise, does not necessarily constitute or imply its endorsement, recommendation, or favoring by the United States government or any agency thereof. The views and opinions of authors expressed herein do not necessarily state or reflect those of the United States government or any agency thereof.

Consistent relativistic treatment of the structure of the deuteron and its electromagnetic interactions¹

Franz Gross

College of William and Mary, Williamsburg, VA 23185, USA

and

Continuous Electron Beam Accelerator Facility

12000 Jefferson Ave, Newport News, Virginia 23606, USA

Abstract

Relativistic calculations of deuteron static properties, the triton binding energy, and deuteron form factors are reviewed. The results show that the covariant formalism is capable of replacing nonrelativistic quantum mechanics, at least for the description of two and three body systems, and that some significant new insights emerge when the dynamics is described relativistically.

I. THE QUIET THEORETICAL REVOLUTION

Let me begin by giving a personal overview of the recent progress in the development of relativistic theories for the treatment of few nucleon systems.

For purposes of this discussion, I will identify four major “schools” or approaches to this problem. The first is the the Hamiltonian Dynamics scheme popularized by Keister and Polyzou [1]. In one application of this approach, the *instant* form, the interaction is included in the hamiltonian, H , while the generators of translations (the momentum operators \mathbf{P}) are chosen to be independent of the interactions. This implies in turn that the rotations (generated by the angular momentum operators \mathbf{J}) are also free of interaction terms, but that the generators of the pure boosts (denoted by \mathbf{K}) contain interaction effects which can be found from the commutation relations of the \mathbf{K} 's with H , \mathbf{P} , and the \mathbf{J} 's. In another application, the *front* form, the interaction is included in the light-front generator $P_- = H - \hat{\mathbf{n}} \cdot \mathbf{P}$, so that the light front three-vector with components $P_+ = H + \hat{\mathbf{n}} \cdot \mathbf{P}$, and $\mathbf{P}_T = \mathbf{P} - \hat{\mathbf{n}} \cdot \mathbf{P} \hat{\mathbf{n}}$ is independent of the interaction. It then turns out that the four generators $K_n = \hat{\mathbf{n}} \cdot \mathbf{K}$, $J_n = \hat{\mathbf{n}} \cdot \mathbf{J}$, and $\mathbf{E}_T = \mathbf{K}_T + \hat{\mathbf{n}} \times \mathbf{J}$ are also independent of the interaction and that two additional generators involving rotations are dependent on the interactions. The light-front choice has the advantage that the interaction enters into only three generators (as opposed to four in the instant form), and that the generator for boosts in one direction is interaction-free, so that some problems can be solved exactly using these operators. The

¹Invited talk presented to the 9th Amsterdam mini-conference, Feb. 1, 1996.

Issues	hamiltonian		covariant	
	instant	front	BS	spectator
exact angular momentum conservation	✓	×	✓	✓
exact treatment of boosts	×	✓	✓	✓
connection to some underlying (field) theory	×	?	✓	✓
conventional QM with a Hilbert space with a positive definite metric	✓	✓	×	×
realistic NN dynamics	✓	×	?	✓
complete $3N$ bound state	✓	×	×	✓
smooth nonrelativistic limit	✓	?	×	✓
current operators consistent with dynamics and Gauge invariance	only to $(v/c)^2$?	✓	✓
singularity free kernels	✓	✓	after Wick rotation	×

Table 1: Strengths (✓) and weaknesses (×) of various relativistic methods.

remaining two methods I will discuss are *manifestly* covariant, so that all amplitudes can be transformed to any frame exactly. For these cases practical applications require the development of a whole new covariant dynamics, and this has been carried out using the Bethe-Salpeter equation [2], or the Spectator (or “Gross”) equation [3].

My assesment of the strengths and weakness of each of these methods is summarized in Table 1. The disadvantage of the hamiltonian approaches is that they do not give results which are exactly covariant (either rotations or boosts must be treated approximately). Furthermore, they depend on phenomenology, and have no connection with any fundamental theory (except, possibly, for some approaches based on rapidly developing light-front field theories). On the other hand, both covariant methods give results which are derivable from field theory (using approximations which can be clearly defined even if they can’t always be fully justified) and are exactly covariant. The disadvantage of covariant approaches is the appearance of negative energy states which require redefinition of both the space of quantum mechanical states and the meaning of the scalar product (it can no longer be a probability density). The covariant method therefore lies outside of conventional quantum theory, and requires the development of new physical principles before it can be defined in

its most general form. My own view is that this latter problem is not as serious as the first three, and that therefore covariant theories are to be preferred on theoretical grounds.

Furthermore, new results show that the phenomenology of few nucleon systems (including the deuteron) can be very well described by modern covariant theory, particularly if the spectator equation is used. This recent development, displayed in the last 5 rows of Table 1, is the quiet revolution I refer to in this section. Recent advances in the description of low energy NN scattering, prediction of the three body binding energy, and the incorporation of gauge invariance into electron-hadron interactions mean that covariant spectator theory is now a mature research tool. In addition, the close correspondence between the relativistic and the nonrelativistic equations means that the origin of any new effects can be examined and connections made with all previous work. The only remaining problem with the spectator method is the presence of spurious singularities in the spectator kernels. But the numerical effect of these singularities is small in all cases which have been studied so far, so this may be largely an esthetic problem.

I will try to persuade you in the following sections that it is no longer sufficient to depend solely on nonrelativistic quantum theory to provide the theoretical framework for a study of few nucleon systems. I will show you examples where precision studies have outgrown the use of nonrelativistic quantum mechanics, and where the use of covariant methods is required.

Before turning to a review of some of these recent developments, I call attention to work by Nieuwenhuis, Tjon, and Simonov [4], who have studied the energy of a two-body bound state which emerges from the assumption that the dynamics is described by the sum of all ladder and crossed ladder diagrams. They have tested this assumption numerically for Φ^3 theory by summing all ladders and crossed ladders using the Feynman-Schwinger path integral formalism. When one of the two particle masses becomes very large, they find that

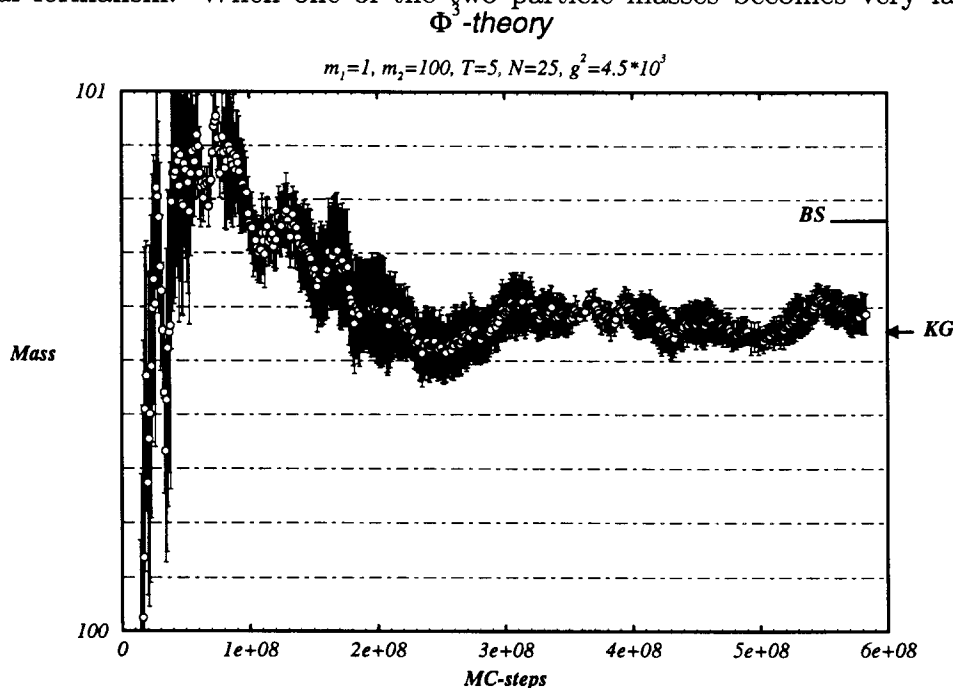

Figure 1: Convergence of a bound state binding energy calculated from the sum of ladder and crossed ladder diagrams in a Φ^3 theory.

the binding energy approaches the same value that is obtained from a *one body* relativistic equation (the Klein-Gordon equation for spin 0 particles) for the lighter particle moving in the effective, instantaneous potential created by the heavier particle. Their results for one case when the ratio of the heavier mass to the lighter mass is 100 is shown in Fig. 1. Note that the exact binding energy (from ladder and crossed ladder diagrams) is very close to the Klein-Gordon result (labeled *KG* on the graph) and substantially different from the result which would have been obtained from the *ladder approximation* to Bethe-Salpeter equation (labeled *BS*). This confirms that crossed ladders give large numerical results and are needed in order to obtain the *one body limit*, as previously demonstrated theoretically [5], and helps place covariant methods on a firmer foundation.

II. NUCLEON-NUCLEON SCATTERING, THE DEUTERON, AND THE TRITON BINDING ENERGY

I now want to describe the (relativistic) properties of the deuteron obtained using the covariant spectator theory, and report on some recent, very exciting results obtained from our relativistic study of the triton binding energy. The two-body work described here was done in collaboration with J. W. Van Orden, and the three-body work with Alfred Stadler. The three-body study lead us to introduce some new features into the relativistic one boson exchange (OBE) model we use, and I will discuss the implications of this new work briefly.

The two body spectator equations are shown diagrammatically in Fig. 2 [6]. One of the nucleons (either one) is restricted to its positive energy mass shell (indicated by the \times in the figure) which reduces the integration over the intermediate four-momentum to a *covariant* three dimensional integral. The interaction kernel must be explicitly antisymmetrized in order to insure that the scattering amplitudes satisfy the Pauli principle exactly.

The covariant spectator deuteron wave function is related to the dNN vertex function, $\Gamma(p, P)$. This vertex is a function of the total four-momentum of the deuteron, $P = p_1 + p_2$, and the relative four-momentum, $p = (p_1 - p_2)/2$. By convention, particle 1 is on-shell, so

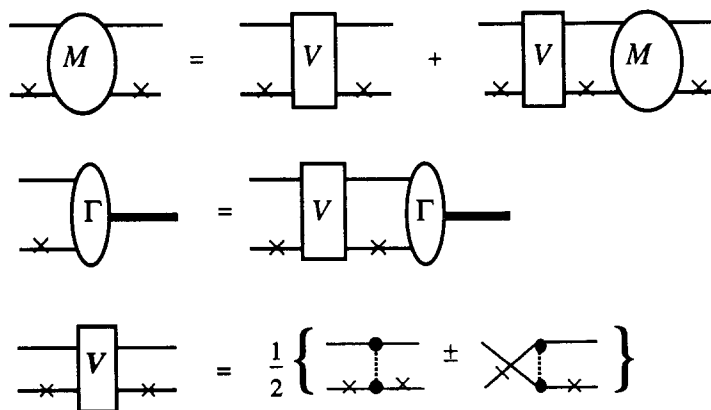

Figure 2: Diagrammatic representation of the spectator equations for NN scattering, the dNN vertex, and the OBE kernel.

that $p_1^2 = m^2$, and, in the rest frame of the deuteron, $m^2 - p_2^2 = M_d(2E_p - M_d)$, where $E_p = \sqrt{m^2 + \mathbf{p}^2}$ is the energy of the on shell nucleon in the rest frame and $p_1 = (E_p, \mathbf{p})$. Since the deuteron mass is less than twice the nucleon mass, $m^2 - p_2^2 > 0$ and particle 2 can never be on shell.

The mathematical connection between the covariant deuteron wave function, Ψ , and the dNN vertex with one N off-shell was developed many years ago [7]:

$$\begin{aligned}\Psi_{\alpha,\lambda}(P,p) &= \frac{1}{\sqrt{2M_d(2\pi)^3}} S_{\alpha\beta}(P-p) [\Gamma(P,p)C]_{\beta\gamma} \bar{u}_\gamma^T(\mathbf{p},\lambda) \\ &= \psi_{\lambda'\lambda}^+(\mathbf{P},\mathbf{p}) u_\alpha(\mathbf{P}-\mathbf{p},\lambda') + \psi_{\lambda'\lambda}^-(\mathbf{P},\mathbf{p}) v_\alpha(\mathbf{p}-\mathbf{P},\lambda')\end{aligned}$$

where S is the nucleon propagator, C is the Dirac charge conjugation matrix, and $u(\mathbf{p},\lambda)$ are Dirac spinors with three-momentum \mathbf{p} and spin projection λ . In the deuteron rest frame the nucleon propagator for the off-shell particle 2 can be expanded in terms of the spinors $u(-\mathbf{p},\lambda')$ and $v(\mathbf{p},\lambda')$, reflecting the separation of the propagator into a sum of terms with positive and negative energy poles. Then the relativistic wave function can be expressed in terms of four scalar wave functions, two required for ψ^+ and two for ψ^-

$$\begin{aligned}\psi_{\lambda'\lambda}^+(\mathbf{0},\mathbf{p}) &= \frac{m}{\sqrt{2M_d(2\pi)^3}} \frac{\bar{u}(-\mathbf{p},\lambda')\Gamma(P,p)C\bar{u}^T(\mathbf{p},\lambda)}{E_p(2E_p - M_d)} \\ &= \frac{1}{\sqrt{4\pi}} \left[u(p)\sigma_1 \cdot \sigma_2 - \frac{w(p)}{\sqrt{8}} (3\sigma_1 \cdot \hat{p}\sigma_2 \cdot \hat{p} - \sigma_1 \cdot \sigma_2) \right] \chi_{1M} \\ \psi_{\lambda'\lambda}^-(\mathbf{0},\mathbf{p}) &= -\frac{m}{\sqrt{2M_d(2\pi)^3}} \frac{\bar{v}(\mathbf{p},\lambda')\Gamma(P,p)C\bar{u}^T(\mathbf{p},\lambda)}{E_p M_d} \\ &= -\sqrt{\frac{3}{4\pi}} \left[v_s(p)\frac{1}{2}(\sigma_1 - \sigma_2) \cdot \hat{p} + \frac{v_t(p)}{\sqrt{8}}(\sigma_1 + \sigma_2) \cdot \hat{p} \right] \chi_{1M}\end{aligned}$$

The functions u and w are the familiar S and D -state wave functions, while v_t and v_s are the spin triplet and singlet P -state wave functions. Fig. 3 displays these wave functions in momentum space for one of our models (a revised version of the Model IIB of Ref. [6]) described below. The normalization condition satisfied by these wave functions is

$$1 = \int_0^\infty p^2 dp \left\{ u^2 + w^2 + v_t^2 + v_s^2 \right\} + \left\langle \frac{\partial V}{\partial M_d} \right\rangle, \quad (1)$$

where $\langle \partial V / \partial M_d \rangle$ is a term arising from the energy dependence of the kernel (see Ref. [6]).

The OBE models used in the present study include the exchange of two pseudoscalar mesons [π and η], two scalar mesons [σ ($I = 0$) and the δ ($I = 1$)], and two vector mesons [ρ and ω]. The one pion exchange term arises from the exchange of physical pions, but the heavier meson exchanges are viewed as a simple way to parametrize an effective NN interaction, and not necessarily related to the exchange of physical mesons with the same quantum numbers. The most general form of the vertex for the coupling of scalar mesons to an off-shell nucleon is

$$g_s \Lambda_s = g_s \left[1 - \frac{\nu_s}{2m} (m - \not{k}' + m - \not{k}) + \frac{\kappa_s}{4m^2} (m - \not{k}') (m - \not{k}) \right], \quad (2)$$

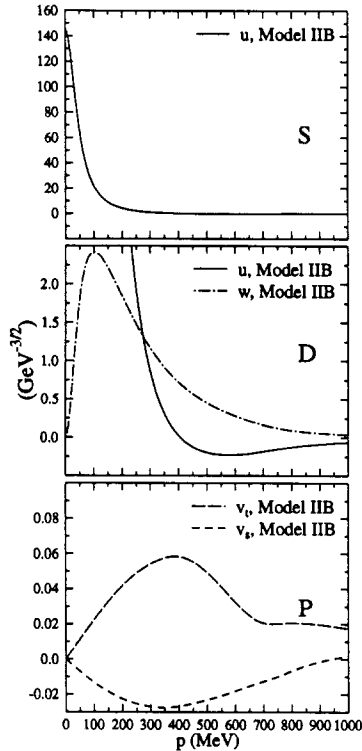

Figure 3: Momentum space deuteron wave functions for Model IIB discussed in the text.

where p and p' are the four momenta of the incoming and outgoing nucleons, and the couplings proportional to ν_s and κ_s do not contribute if the nucleons are on-shell. As far as I know, these off-shell couplings have never been studied previously, and I will discuss the importance of the couplings proportional to ν_s below.

Similarly, the most general form of the vertex for the coupling of pseudoscalar mesons to an off-shell nucleon is

$$\begin{aligned}
 g_p \Lambda_p &= g_p \left[\gamma^5 - \frac{\nu_p}{2m} \left[(m - \not{p}') \gamma^5 + \gamma^5 (m - \not{p}) \right] + \frac{\kappa_p}{4m^2} (m - \not{p}') \gamma^5 (m - \not{p}) \right] \\
 &= g_p \left[(1 - \nu_p) \gamma^5 + \frac{\nu_p}{2m} \gamma^5 \not{q} + \kappa_p \dots \right]
 \end{aligned}$$

where we see that $\nu_p = 1 - \lambda_p$, where λ_p is the pseudoscalar–pseudovector mixing parameter previously discussed by us in the context of OBE models [6]. Finally, the most general vertex for the coupling of vector mesons to off-shell nucleons contains 6 parameters. In our previous studies we included three of these, and wrote the vector meson vertex function in the form

$$\begin{aligned}
 g_v \Lambda_v^\mu &= g_v \left[\gamma^\mu - \frac{\kappa_v}{2m} i \sigma^{\mu\nu} q_\nu + \frac{\kappa_v (1 - \lambda_v)}{2m} \left[(m - \not{p}') \gamma^\mu + \gamma^\mu (m - \not{p}) \right] + \dots \right] \\
 &= g_v \left[\left[1 + \kappa_v (1 - \lambda_v) \right] \gamma^\mu - \frac{\kappa_v \lambda_v}{2m} i \sigma^{\mu\nu} q_\nu - \frac{(1 - \lambda_v) \kappa_v}{2m} P^\mu + \dots \right]
 \end{aligned}$$

where the original motivation for introducing λ_v was to allow for a replacement of the tensor $\sigma^{\mu\nu} q_\nu$ by a linear combination of γ^μ and P^μ , as suggested by the Gordon decomposition

(which holds only on-shell). However, we see that the replacement $\nu_\nu = \kappa_\nu(1 - \lambda_\nu)$ shows that this mixing could be present even if $\kappa_\nu = 0$, and that there is no *a priori* restriction which we can place on the value of λ_ν . All of these parameters are free to be fixed by the data.

In addition to the meson couplings (and masses), the models include a universal meson form factor

$$f(q^2) = \frac{(\Lambda_m^2 - \mu_i^2)^2 + \Lambda_m^4}{(\Lambda_m^2 - q^2)^2 + \Lambda_m^4}$$

where μ_i is the mass of the i th exchanged meson, and Λ_m is a universal constant. Since the nucleon is off-shell, we also introduce a nucleon form factor

$$h(p^2) = \frac{(\Lambda_N^2 - m^2)^2 + (\Lambda_0^2 - m^2)^2}{(\Lambda_N^2 - m^2)^2 + (\Lambda_0^2 - p^2)^2}, \quad (3)$$

where Λ_N is another parameter, and we have studied cases in which $\Lambda_0 = \Lambda_N$, or $\Lambda_0 = m$.

Recently Alfred Stadler and I finished a covariant calculation of the triton binding energy using the relativistic three-body spectator equations. These covariant three body equations restrict two of the three particles to their mass shell, which fixes both of the relative energies covariantly and leaves equations which depend on only two three-momentum variables, as in the nonrelativistic case. The resulting equations have a Faddeev-like structure, and are driven by two-body amplitudes with one particle off-shell: precisely those obtained from the two-body equations illustrated in Fig. 2. Hence, as in the nonrelativistic case, the triton binding energy can be predicted uniquely from any two-body force model. While the general form of these equations for both three spinless particles [8] and three spin 1/2 particles [9] was described some time ago, now exact numerical solutions have been obtained using a new, more convenient form of the equations [10,11].

We first obtained solutions for the three body binding energy predicted by models similar to Model IIA [6] mentioned above. These models had no off-shell σ or δ couplings; *i.e.* the parameters ν_σ , ν_δ , κ_σ , and κ_δ defined in Eq. (2) were all zero. We were disturbed to learn that these models gave much too small a result; the binding energy was in the vicinity of -6.0 MeV, much less than the experimental result of -8.48 MeV. After considerable study we found that the binding energy could be improved by allowing the off-shell parameters ν_σ and ν_δ to be non-zero. We found that if the ν_σ and ν_δ parameters were scaled by the relations

$$\begin{aligned} \nu_\sigma &= -0.75\nu \\ \nu_\delta &= 2.6\nu, \end{aligned}$$

with ν varying from 0 to 2.6, the three body binding energy could be made to vary smoothly from about -6.0 MeV (for $\nu = 0$) to as large as -10.0 MeV (for the largest $\nu = 2.6$). In each case, *all other parameters*, except the pion coupling constant and the masses of the non-scalar mesons, *were varied to give the best fit to the two body data* before the three body binding energy was calculated. The deuteron properties and meson parameters for Model IIB (revised) and for five of the family of new models with varying off-shell scalar couplings are given in Table 2. Note that some of the meson parameters (especially g_δ , g_ω , and g_ρ) are very sensitive to the value of ν , while others (including the scalar meson masses, the cutoff

OBE parameter	IIB (revised)	W00 $\nu = 0$	W05 $\nu = 0.5$	W16 $\nu = 1.6$	W18 $\nu = 1.8$	W26 $\nu = 2.6$
G_π	13.15	13.34	13.34	13.34	13.34	13.34
G_η	3.02	3.49	2.78	3.03	3.37	4.24
G_σ	5.30	5.61	5.36	5.12	4.83	4.12
ν_σ	0.0	0.0	-0.375	-1.20	-1.35	-1.95
G_δ	0.33	0.19	0.49	1.18	0.91	0.37
ν_δ	0.0	0.0	1.30	4.16	4.68	6.76
G_ω	10.09	13.04	13.88	16.70	16.08	14.39
G_ρ	0.44	0.58	0.67	0.99	0.95	0.75
λ_ρ	0.863	1.55	1.51	1.57	1.57	1.56
$-E_T$	~ 6.0	~ 6.1	~ 6.5	~ 8.2	~ 8.6	~ 10.0
D/S	0.0247	0.0252	0.0253	0.0255	0.0255	0.0255
P_d	5.0	5.3	5.6	6.6	6.7	6.8
P_{v_t}	0.049	0.014	0.010	0.001	0.002	0.004
P_{v_s}	0.009	0.006	0.003	0.001	0.001	0.004
$\langle V' \rangle$		2.5	1.5	-1.8	-2.2	-3.3

Table 2: Deuteron properties and OBE parameters for six models discussed in the text. The couplings are all dimensionless, with $G_\pi = g_\pi^2/4\pi$, and E_T is in MeV. The last four rows are *probabilities*. Model IIB has $\Lambda_0 = \Lambda_N$; the rest have $\Lambda_0 = m$ [recall Eq. (3)].

masses, and κ_ρ not given in the table) were less sensitive. All of the new models, with a name beginning with the letter W, gave an excellent value for the deuteron D/S ratio, and varying percentages for the D and P state probabilities. Note that the derivative term in the normalization condition (1), $\langle V' \rangle = \langle \partial V / \partial M_d \rangle$, varies significantly with ν . The variation of the triton binding energy for this family of models is shown graphically in the upper panel of Fig. 4.

However, the remarkable feature of this result is that the introduction of the off-shell parameter ν permits an improvement in the quality of the fit to the two body data, and that the value of ν which gives the best triton binding energy also gives the best two body fit. The lower panel of Fig. 4 shows how the χ^2 for the two body fit varies with ν , and comparison of the two panels shows that the value of $\nu \simeq 1.9$ gives both the best value of E_T and the smallest χ^2 . We have presented our results in this fashion because the fact that ν can also improve the fit to two body data was not realized until the three body calculations were nearly completed, and it is unlikely that we would have discovered these improved two body models if we had not been trying to improve our value of the triton binding energy.

Unfortunately, we have not yet concluded our study of the convergence of the binding energy calculation (the results shown in Fig. 4 are for states with $J \leq 2$ and the contributions from states up to $J \leq 4$ are currently being studied), and we have so far omitted some effects resulting from some off-diagonal coupling of negative energy channels (which we believe will be small), so these are only preliminary results.

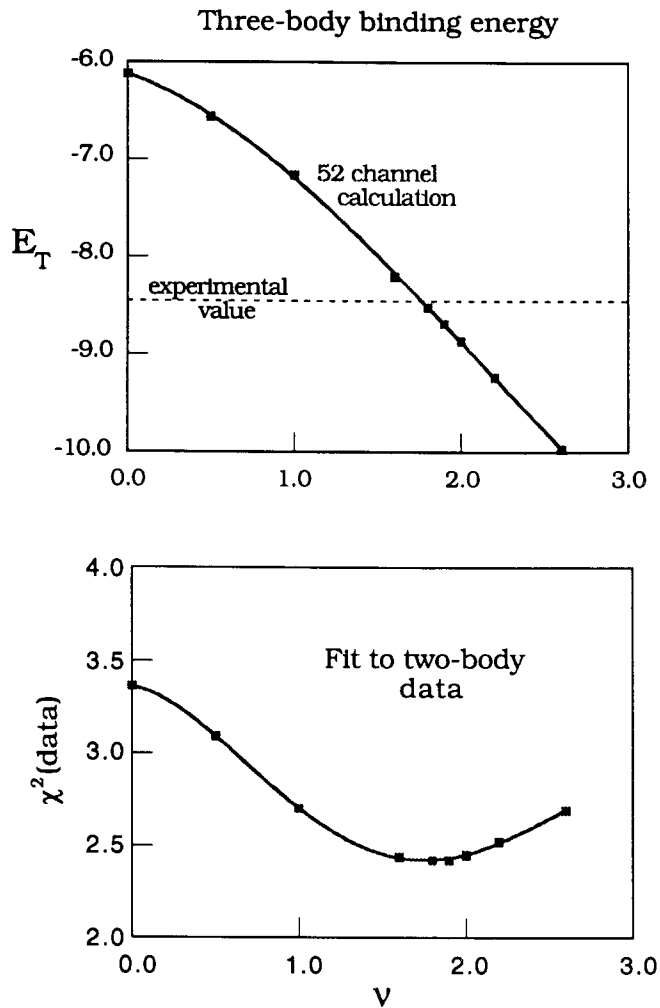

Figure 4. Triton binding energy, E_T (upper panel) and the χ^2 for the fits to the two body data (lower panel) versus the scalar meson off-shell parameter ν defined in the text. Note that the experimental binding energy and the best fits to the two body data are both obtained at about the same value of $\nu \simeq 1.9$.

I conclude this section with the following comments:

- The relativistic OBE models with off-shell couplings give quantitatively excellent fits to the deuteron parameters and NN scattering data below 350 MeV.
- The 13 ± 1 parameters used in the OBE models are theoretically meaningful couplings and masses related to a covariant description of the effective NN interaction.
- Except for the pion, I do not view the 6 bosons of the OBE model as related to real, physically observable mesons. They are merely parameterizations of the effective interaction, and in this sense the appearance of off-shell couplings is not unexpected.

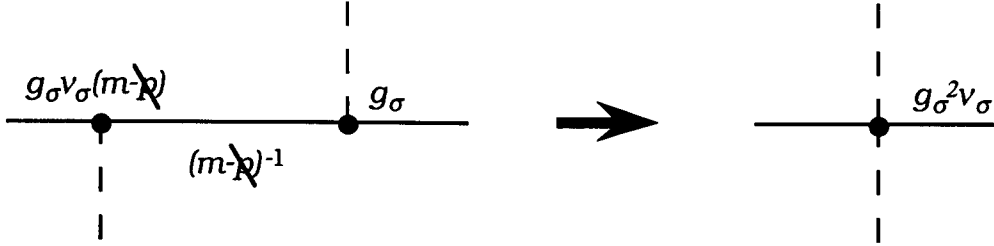

Figure 5. The left diagram with one off-shell coupling is equivalent to the right diagram with a two-meson contact interaction. The contact interaction can generate a two-meson exchange force if both mesons couple to the same second nucleon, or a three body force if they couple to different nucleons.

- The successful description of the triton binding energy shows that off-shell couplings of scalar mesons are essential. This insight could not have been obtained from a nonrelativistic calculation.

Note that an OBE theory with off-shell couplings is equivalent to some theory with no off-shell couplings, but with two (and many) boson exchange forces and three- (and n)-body forces. This is illustrated in Fig. 5. A factor of $(m - \not{k})$ in a meson vertex function will cancel the nucleon propagator, $(m - \not{k})^{-1}$, which connects two meson interactions, shrinking the interaction to a point and generating either a two boson exchange force or, if a third particle is present, a three-body force. The same mechanism can occur in sequence, generating effective couplings of n mesons to a nucleon at a single point. Such interactions can generate n -meson exchange forces and n -body forces. The implications of these observations is under investigation.

III. DEUTERON FORM FACTORS

Calculations of the electromagnetic form factors of the deuteron continue to be an important application of relativistic theories, and a necessary first test of any new development. In 1989 Hummel and Tjon (HT) argued that large $\rho\pi\gamma$ and $\omega\sigma\gamma$ exchange currents were required in order to account for the high Q^2 behavior of these form factors [12]. However, in order to estimate the size of these exchange currents one must know the form factors for the elementary $\rho\pi\gamma$ and $\omega\sigma\gamma$ couplings. HT used a vector dominance model to estimate these form factors and, as shown in Fig. 6, this estimate (labeled VDM) gives a form factor which is very large at high Q^2 . Ito and I calculated the $\rho\pi\gamma$ form factor from a covariant separable quark model [13] and obtained a smaller result. Other recent quark model calculations shown in Fig. 6 give still results which are still smaller [14]. Unfortunately these smaller form factors give much smaller exchange currents and spoil the agreement which HT obtained, leaving the explanation of the deuteron form factors still uncertain.

A recent relativistic calculation of the deuteron electromagnetic form factors, done with J. W. Van Orden and Neal Devine [15], gives a picture of the physics which is very different

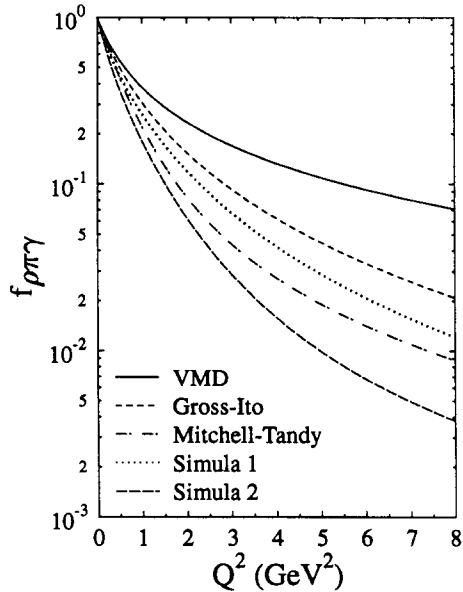

Figure 6: Various models of the $\rho\pi\gamma$ form factor.

from that suggested by the HT calculation. Before discussing these results, I want to very briefly describe the spectator theory of the elastic and inelastic scattering from the deuteron.

The relativistic diagrams which occur in the inelastic theory ($e + d \rightarrow e' + p + n$) are shown in Fig. 7 and the ones which appear for elastic scattering ($e + d \rightarrow e' + d$) are shown in Fig. 8. The inelastic case requires the evaluation of three types of contributions: relativistic impulse approximation (RIA), final state interactions (FSI), and interaction currents (IAC). These diagrams are evaluated using precisely the same relativistic deuteron wave function and scattering amplitude defined in the previous section. The interaction current is obtained from the OBE interaction kernel, as shown symbolically in Fig. 9.

I will discuss the diagrams (a), (b), and (c) shown in Figs. 7 and 8 in somewhat more detail. In early applications of the spectator theory [16] it was assumed that the sum of diagrams (b) and (c), where one of the struck nucleons is on-shell, was equal to diagram (a), with the spectator on-shell. In the elastic case, the relativistic impulse approximation (RIA) was therefore defined to be $2 \times$ (a). Later I realized that when the

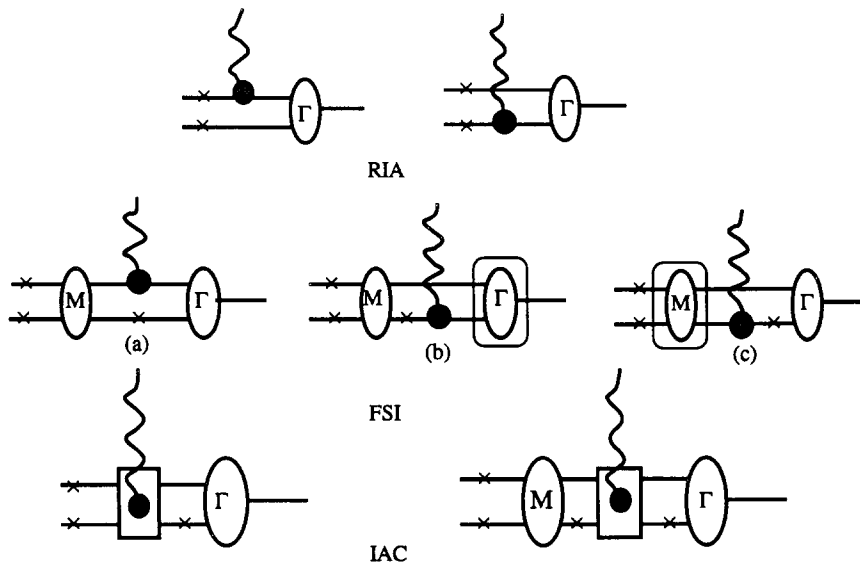

Figure 7: The complete set of diagrams needed for a gauge invariant calculation of deuteron electrodisintegration in the spectator theory.

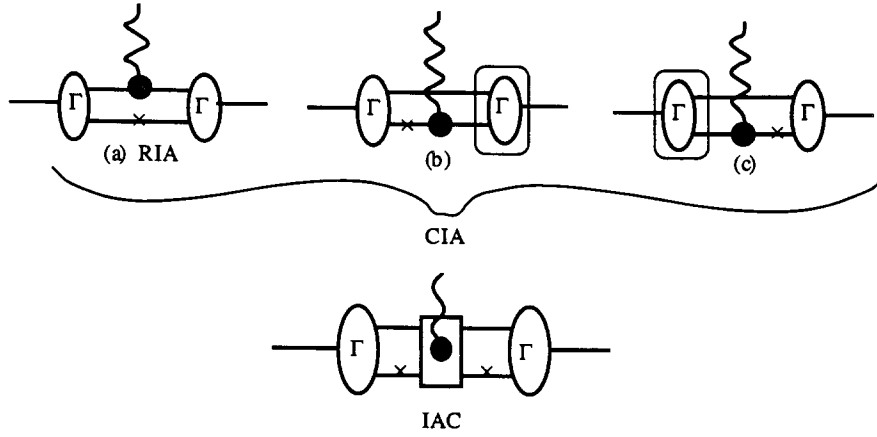

Figure 8: Diagrammatic representation RIA, the CIA, and the interaction current contributions to the deuteron form factors.

kernel depends on the total energy (which is the case for the symmetrized OBE models currently being used) diagrams (b) and (c) differ from diagram (a), and this difference must be taken into account if gauge invariance is to be maintained exactly (in the inelastic case) [17] or if the derivative term $\langle V' \rangle$ in the normalization condition Eq. (1) is to emerge in the $Q^2 \rightarrow 0$ limit of elastic scattering [this term comes only from diagrams 8(b) and (c)]. We now refer to the exact sum of the three diagrams (a) + (b) + (c) of Fig. 8 as the complete impulse approximation (CIA). Calculation of the CIA requires knowledge of amplitudes with

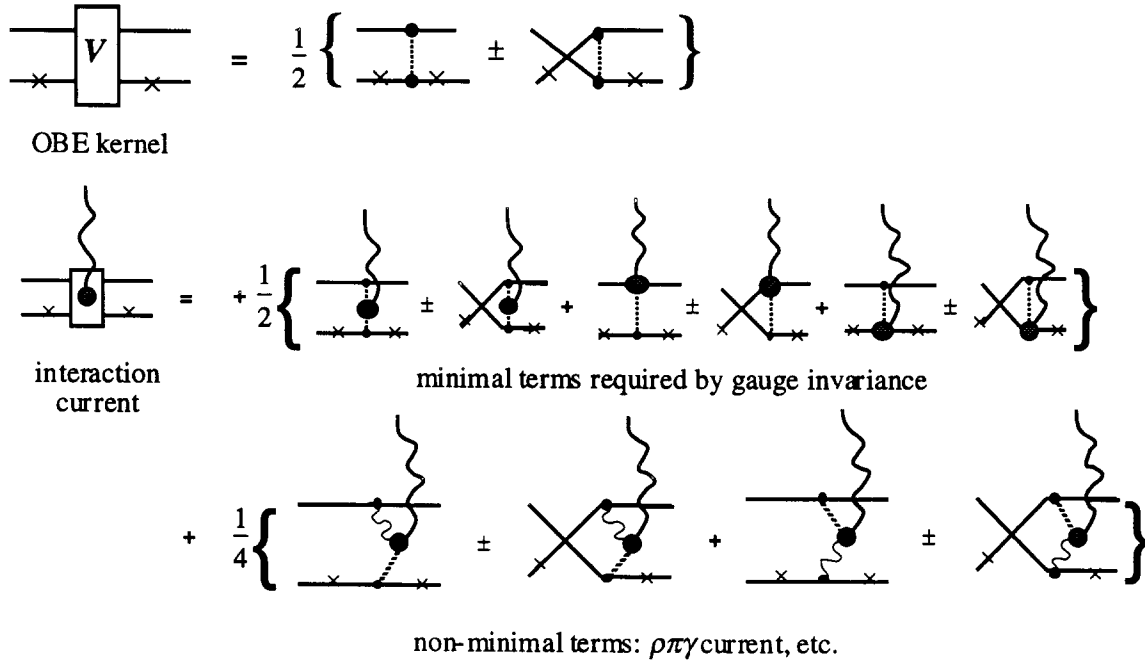

Figure 9: The interaction current contains minimal terms with a structure determined by the interaction kernel (OBE in the figure) and separately gauge invariant non-minimal terms. The $\rho\pi\gamma$ current is non-minimal.

both nucleons off-shell (shown enclosed by rounded squares in Figs. 7 and 8). These can be obtained by quadrature from the on-shell amplitudes using a kernel which connects the channels with one particle on-shell to those with both particles off-shell. This kernel is given by the theory.

Our introduction of a nucleon form factor, Eq. (3), requires modification of the nucleon current in order to maintain gauge invariance. Following the technique of Ref. [17], we introduce a *reduced* current operator, j_R^μ

$$j^\mu(p', p) = h(p'^2) j_R^\mu(p', p) h(p^2),$$

where j^μ is the full current operator, p' and p are the four-momenta of the outgoing and incoming nucleons, respectively, and h is the strong nucleon form factor introduced in Eq. (3). The reduced current operator satisfies the Ward-Takahashi identity

$$(p' - p)_\mu j_R^\mu(p', p) = \frac{(m - \not{p}')}{h^2} - \frac{(m - \not{p})}{h'^2}$$

where $h = h(p^2)$ and $h' = h(p'^2)$. One solution of this equation is

$$\begin{aligned} j_R^\mu(p', p) = & f_0(p'^2, p^2) \left[\gamma^\mu + (F_1(Q^2) - 1) \left(\gamma^\mu - \frac{\not{p} \not{p}'}{q^2} \right) \right] \\ & + h_0(p'^2, p^2) i \frac{F_2(Q^2)}{2m} \sigma^{\mu\nu} q_\nu + g_0(p'^2, p^2) \frac{(m - \not{p}')}{2m} \gamma^\mu \frac{(m - \not{p})}{2m} \\ & + g_0(p'^2, p^2) (F_3(Q^2) - 1) \frac{(m - \not{p}')}{2m} \left(\gamma^\mu - \frac{\not{p} \not{p}'}{q^2} \right) \frac{(m - \not{p})}{2m}, \end{aligned}$$

where the functions f_0 and g_0 are determined by the WT identity

$$\begin{aligned} f_0(p'^2, p^2) &= \frac{1}{h'^2} \left(\frac{p'^2 - m^2}{p'^2 - p^2} \right) + \frac{1}{h^2} \left(\frac{p^2 - m^2}{p^2 - p'^2} \right) \\ g_0(p'^2, p^2) &= \frac{4m^2}{h^2 h'^2} \left(\frac{h^2 - h'^2}{p'^2 - p^2} \right) \end{aligned}$$

and F_3 and h_0 are unconstrained except for the requirements that

$$F_3(0) = 1 \quad h_0(m^2, m^2) = 1.$$

Following the original convention, we continue to use the on-shell current operator in the RIA. The on-shell operator can be obtained from the off-shell operator by setting $g_0 = 0$ and $f_0 = h_0 = h = h' = 1$. Our off-shell operator is fixed by the conditions $F_3(Q^2) = G_E(Q^2)$ and $h_0 = f_0$. We find that modest variations in F_3 and the replacement $h_0 = 1$ do not give large effects.

Some recent results for the deuteron structure functions obtained using Model IIB are shown in Figs. 10 and 11. Here we show A , B , and T_{20} defined by

$$\begin{aligned} A(Q^2) &= G_C^2(Q^2) + \frac{2}{3}\eta G_M^2(Q^2) + \frac{8}{9}\eta^2 G_Q^2(Q^2) \\ B(Q^2) &= \frac{4}{3}\eta(1 + \eta) G_M^2(Q^2) \\ T_{20}(Q^2) &= -\sqrt{2}\frac{4}{3}\eta \frac{G_C(Q^2)G_Q(Q^2) + \frac{1}{3}\eta G_Q^2(Q^2)}{G_C^2(Q^2) + \frac{8}{9}\eta^2 G_Q^2(Q^2)} \end{aligned}$$

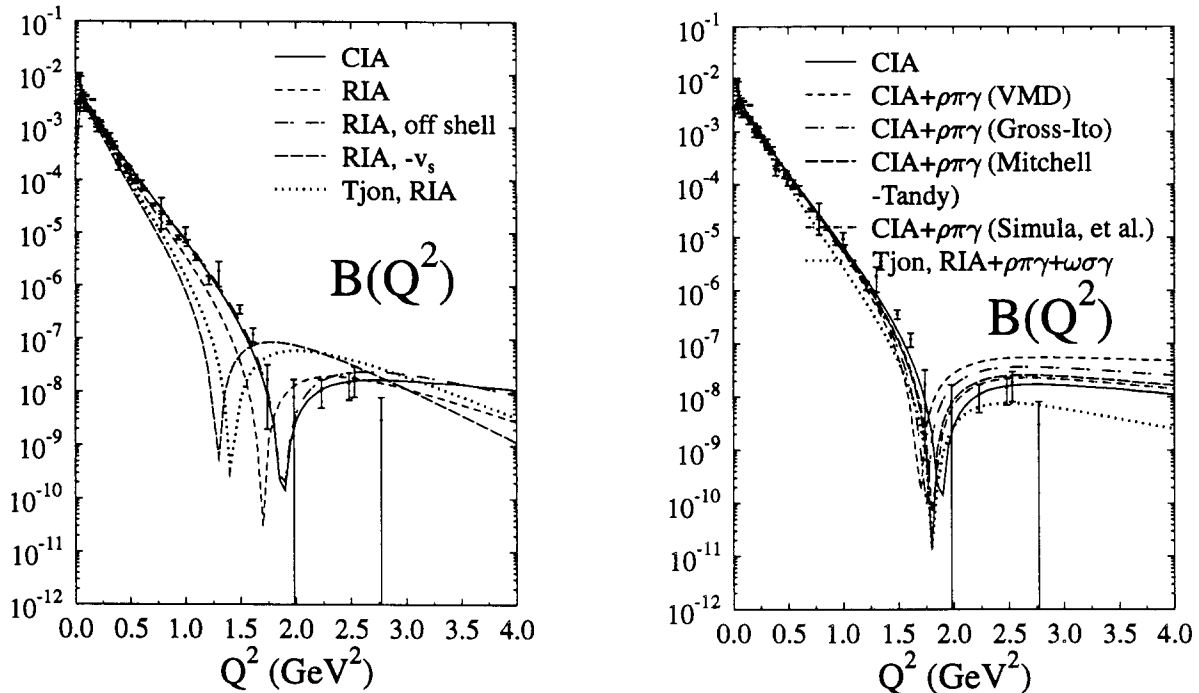

Figure 10: The B structure function for Model IIB. Left panel: The CIA contribution discussed in the text. Right panel: The effect of $\rho\pi\gamma$ exchange currents with various $\rho\pi\gamma$ form factors.

where $\eta = Q^2/(4M_d^2)$ and G_C , G_M , and G_Q are the charge, magnetic, and quadrupole form factors of the deuteron [16].

The B structure function turns out to be very sensitive to the details of the dynamics. The left panel of Fig. 10 compares our CIA calculation of B with the RIA calculation of HT. Note that our CIA gives a very good description of the data, leaving very little room for exchange currents. The major numerical difference between the new CIA and the old RIA is the use of the off-shell current operator; if the off-shell operator is used in the RIA, it is indistinguishable from the CIA over the entire region of Q^2 . The remaining difference between our RIA and the HT result is due to the small relativistic P -state components. If we change the sign of the small component, v_s , the RIA (labeled RIA, $-v_s$ in the figure) is not very different from the HT result, and far from the data.

This last observation is very surprising, because the probability of the v_s state is only 0.009%! How can such a small component have such a large effect? The reason is due to interference between the small P states and the larger S and D -state components. The magnetic form factor can be decomposed into electric and magnetic parts,

$$G_M(Q^2) = G_{E_s}(Q^2) D_M^E(Q^2) + G_{M_s}(Q^2) D_M^M(Q^2)$$

where G_{E_s} and G_{M_s} are the isoscalar electric and magnetic form factors of the nucleon. Expanding the body form factors to order $(v/c)^2$ gives

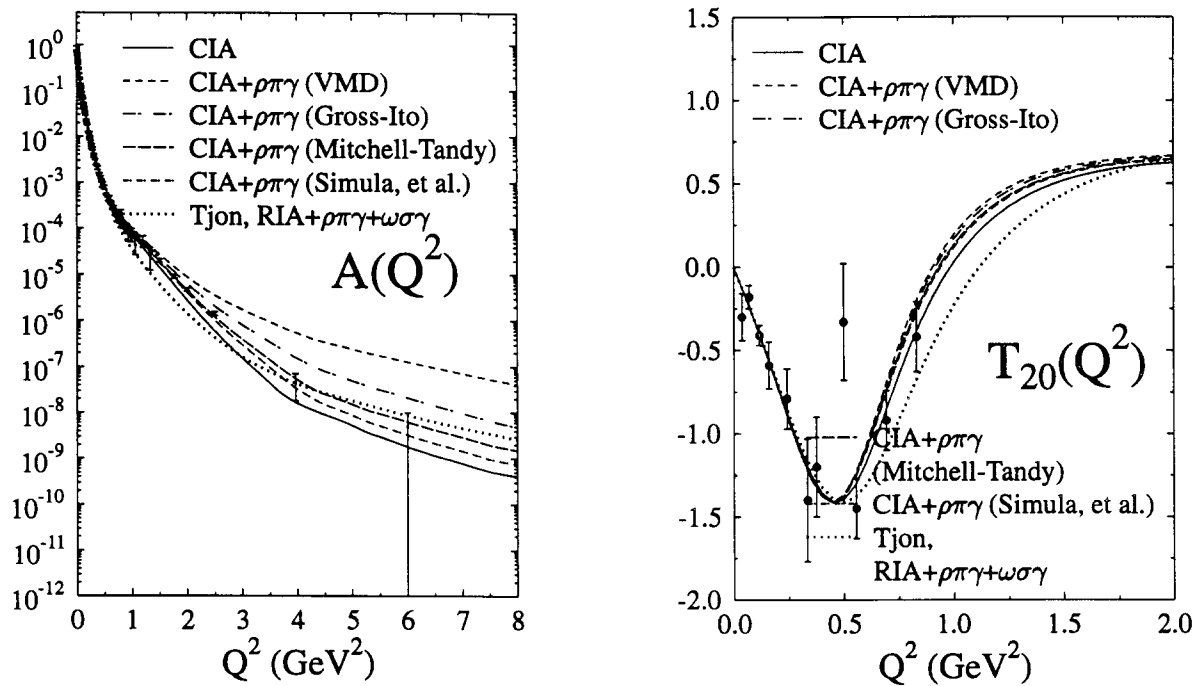

Figure 11: The left pannel shows A and the right pannel T_{20} for the cases shown in Fig. 10.

$$D_M^M(Q^2) = \int_0^\infty dr \left\{ [2u^2(r) - w^2(r)] j_0(\tau) + [\sqrt{2}u(r)w(r) + w^2(r)] j_2(\tau) \right\}$$

$$D_M^E(Q^2) = \int_0^\infty dr \left\{ \frac{3}{2}w^2(r) + \frac{2}{\sqrt{3}}mr \left(v_t(r) \left[\frac{1}{\sqrt{2}}u(r) - w(r) \right] - v_s(r) \left[u(r) + \frac{1}{\sqrt{2}}w(r) \right] \right) \right\} [j_0(\tau) + j_2(\tau)]$$

where $\tau = Qr/2$ [16]. Note the appearance of the interference term in D_M^E . This term is dominated by the region where the S -state wave function is larger than the D -state wave function, and therefore is large only if the P -state wave functions v_t and v_s have opposite signs. This is the case for Model IIB, and we have confirmed that this term accounts quantitatively for the bulk of the effect shown in Fig. 10. I noticed many years ago that the same term gives a relativistic correction to the deuteron magnetic moment sufficient to give the correct value when the D state probability is 7% [18]:

$$\Delta\mu_d = \frac{2}{\sqrt{3}}m \int_0^\infty r dr \left\{ v_t(r) \left[\frac{1}{\sqrt{2}}u(r) - w(r) \right] - v_s(r) \left[u(r) + \frac{1}{\sqrt{2}}w(r) \right] \right\}$$

The right pannel of Fig. 10 shows that the $\rho\pi\gamma$ exchange current gives only a small contribution to the B structure function, especially if one of the smaller $\rho\pi\gamma$ form factors is used. We conclude that Model IIB gives a good explanation of the B structure function.

The predictions for the A and T_{20} structure functions are shown in Fig. 11. The A structure function is most sensitive to the $\rho\pi\gamma$ form factor, but a reasonable result is obtained for all structure functions if a small $\rho\pi\gamma$ form factor is used.

Our study of the deuteron form factors leads to the following conclusions:

- In the neighborhood of the zero, the B structure function is very sensitive to the small relativistic P -state components of the deuteron wave function. This is a surprising result.
- There is no compelling evidence for the existence of large isoscalar exchange currents.
- These observations would have been impossible without the use of a covariant model.

However, before we can draw definitive conclusions about the physics of the deuteron form factors, we must examine the results predicted by the models with non-zero values of ν . These models tend to have very tiny P -states, but also generate a new family of isoscalar exchange currents arising from the energy dependence of the off-shell couplings proportional to ν . It remains to be seen whether or not these new exchange currents will play the role played previously by the P -states.

IV. CONCLUSIONS

I offer the following concluding remarks:

- A consistent, covariant formalism capable of replacing nonrelativistic quantum mechanics (at least for two and three nucleon systems) is fully developed and has become a practical tool for calculations. In this formalism boosts and rotations can be treated *exactly*.
- Some significant new insights, which could not have been discovered using nonrelativistic theory, are emerging. In this talk I have discussed (i) the importance of off-shell couplings, and (ii) the effects of the deuteron P -states.
- The most significant legacy of relativistic methods may not be the kinematical effects which everyone knows are present, but the light such an approach can shed on the nature of the dynamics. The relativistic methods described here provide a natural description of the energy dependence of the effective NN interaction.

I thank the organizers for inviting me to speak, and giving me with another opportunity to visit NIKHEF. The contributions of NIKHEF to our current understanding of hadronic physics have been substantial, and it is always exciting to come here for a visit. Finally, it is a pleasure to acknowledge the support of the US Department of Energy (DOE) through Grant No. DE-FG05-88ER40435, and through CEBAF.

REFERENCES

- [1] B. D. Keister and W. N. Polyzou, *Adv. Nucl. Phys.* **20**, 225 (1991). See also the *Round Table Discussion* by F. Coester *et al*, in the Proceedings of the Trieste Conference (1995), and the discussion lead by J. A. Tjon and F. Lev, *Proceedings of the XVth European Conference on Few Body Problems in Physics*, eds. R. Guardiola and V. Vento, *Few-Body Systems* **8** (1995)..
- [2] J. Fleisher and J. A. Tjon, *Nucl. Physics.* **B84**, 375 (1975); *Phys. Rev. D* **15**, 2537 (1977); **D 21**, 87 (1980)
- [3] F. Gross, *Phys. Rev.* **186**, 1448 (1969); *Phys. Rev. D* **10**, 223 (1974); **C 26**, 2203 (1982).
- [4] T. Nieuwenhuis, J. A. Tjon, and Yu. A. Simonov, *Few-Body Systems, Suppl.* **7**, 286 (1994).
- [5] See the 1982 paper listed in Ref. [3].
- [6] F. Gross, J. W. Van Orden, and K. Holinde, *Phys. Rev. C* **45**, 2094 (1992).
- [7] W. W. Buck and F. Gross, *Phys. Rev. D* **20**, 2361 (1979).
- [8] F. Gross, *Phys. Rev. C* **26**, 2226 (1982).
- [9] F. Gross, lectures at the University of Hannover (1982), unpublished.
- [10] A. Stadler and F. Gross, in *Few Body Problems in Physics*, AIP Conference Proceedings #334, proceedings of the XIVth International Conference (1995), F. Gross, ed., p. 867.
- [11] F. Gross, A. Stadler, J. W. Van Orden, and N. Devine, *Proceedings of the XVth European Conference on Few Body Problems in Physics*, eds. R. Guardiola and V. Vento, *Few-Body Systems* **8**, 269 (1995).
- [12] E. Hummel and J. A. Tjon, *Phys. Rev. Letters* **63**, 1788 (1989); *Phys. Rev.* **C42**,423 (1990).
- [13] H. Ito and F. Gross, *Phys. Rev. Letters* **71**, 2555 (1993).
- [14] K. L. Mitchell, Ph.D. thesis, Kent State University, 1995 (unpublished); K. L. Mitchell and P. C. Tandy, private communication; S. Simula, et.al., private communication.
- [15] J. W. Van Orden, N. Devine, and F. Gross, *Phys. Rev. Letters* **75**, 4369 (1995).
- [16] R. Arnold, C. Carlson, and F. Gross, *Phys. Rev. C* **21**, 1426 (1980).
- [17] F. Gross and D. O. Riska, *Phys. Rev. C* **36**, 1928 (1987).
- [18] F. Gross, in *Proceedings of the 6th International Conference on Few Body Problems*, Quebec City, ed. by R. J. Slobodrian *et al* (Univ. of Laval Press, Quebec, 1975), p. 782.