

44
CERN - MT 95-16 SM

EUROPEAN ORGANIZATION FOR NUCLEAR RESEARCH

CERN - MT DIVISION

su 9617



CERN MT/95-16 (SM)



CERN-MT-95-16

**A Device for Laser Annealing of Nb Films
in Nb coated Cu Cavities**

K. Geissler, D. Lacarrère, A. Rijllart, E. Scavino
CERN, 1211 Geneva 23, Switzerland

Abstract

Theoretical considerations as well as preliminary experimental evidence suggest that the Q_0 degradation with increasing accelerating field in Nb coated cavities strongly depends on Nb crystal grain size. In order to improve cavity performance at high fields by enlarging the grain size, Nb films on flat samples have been annealed using an excimer laser at 308 nm wavelength and energy densities up to 6 J/cm^2 . This process resulted in grain size increase from about 100 nm to about 400 nm. Based on these encouraging results, an apparatus to anneal Nb films inside a 1500 MHz cavity has been designed and built at CERN. This system, which is now operational but which has not yet been used for cavity annealing, is described in this paper.

Paper presented at the 7th Workshop on RF Superconductivity, Saclay, France,
October 17-20, 1995

Geneva, Switzerland
29 January 1996

A Device for Laser Annealing of Nb Films in Nb coated Cu Cavities

K. Geissler, D. Lacarrère, A. Rijllart, E. Scavino
CERN, 1211 Geneva 23, Switzerland

Abstract

Theoretical considerations as well as preliminary experimental evidence suggest that the Q_0 degradation with increasing accelerating field in Nb coated cavities strongly depends on Nb crystal grain size. In order to improve cavity performance at high fields by enlarging the grain size, Nb films on flat samples have been annealed using an excimer laser at 308 nm wavelength and energy densities up to 6 J/cm². This process resulted in grain size increase from about 100 nm to about 400 nm. Based on these encouraging results, an apparatus to anneal Nb films inside a 1500 MHz cavity has been designed and built at CERN. This system, which is now operational but which has not yet been used for cavity annealing, is described in this paper.

1. Introduction

Superconducting Nb coated Cu (Nb/Cu) cavities have many advantages compared to bulk Nb cavities, in terms of thermal stability, higher quality factor, insensitivity to trapped earth magnetic field and cost [1]. But quality factor (Q_0) degradation is usually observed when the accelerating field increases.

Theoretical considerations and preliminary experimental evidence suggest that this Q_0 degradation strongly depends on Nb crystal grain size in Nb coatings. In order to improve the cavity performance at high fields by enlarging the Nb grain size, pioneering work [2] by laser annealing of Nb films deposited on flat samples using XeCl excimer laser at 308 nm wavelength and fluence up to 6 J/cm² has been performed. The surface remelting process resulted in an increase of the Nb grain size from about 100 nm to about 400 nm.

On the basis of these encouraging results, an apparatus, nicknamed "ELSA", acronym of Excimer Laser Surface Annealing, has been designed and built at CERN. This experimental facility, still in pre-commissioning phase, is dedicated to annealing Nb films inside 1500 MHz monocell cavities.

In this paper, the construction and pre-commissioning of the opto-mechanical apparatus are described. The annealing procedure which will be applied as soon as possible, is also reported.

2. ELSA apparatus

The general layout of the ELSA facility is schematically presented in Fig. 1. The opto-mechanical device consists of a XeCl excimer laser (simulated by a HeCd laser in the pre-commissioning phase), an optical bench for forming the laser beam using appropriate optics (deflecting mirrors, attenuator, homogenizer, HeNe pilot laser), a structure holding and rotating vertically a 1500 MHz cavity or a sample holder (Fig. 2), a periscope holding the final focusing lens and the tilting mirror, which can move up and down inside the cavity. By means of a combination of movements of optical components and cavity rotation, the annealing of the upper cavity half-cell can be carried out.

The experiment makes use of a powerful XeCl excimer laser, generating UV light at 308 nm wavelength with an energy of 0.7 J at 10 Hz. To obtain fluences of 3 to 6 J/cm², demagnification of the excimer laser beam is necessary. For homogeneous energy distribution in the laser spot, a homogenizer is used which chops the beam into quarters and overlaps them in the plane of a "mask" which is then projected by a focusing lens onto the target.

The principle of ELSA is that the laser beam has to be brought in a controlled manner to all points of the inner surface of the cavity. To this end, it will be swept in a sort of continuous spiral over the entire inner surface. For simplicity of construction, the various movements needed have been made independent of each other. There are two principle movements: a) rotation of the cavity about its vertical axis, and b) tilt mirror action about its horizontal axis, allowing the laser beam to be moved in a vertical plane.

These two movements are sufficient to reach all points inside the cavity, but due to the geometrical form of the cavity two more movements are necessary: c) the focusing lens and the tilt mirror have to move vertically along the cavity axis kept by a periscope to maintain the laser spot size constant; d) the "mask" has to follow the movements of the focusing lens to keep the demagnification and hence the laser fluence constant.

The control of the opto-mechanical elements is performed by a personal computer system which uses four industrial stepping motors with their controllers and one DC operated motor. Five position encoders and a joulemeter are read by the computer to monitor the operations. A computer programme has been developed at CERN using LabView under Windows for the control of the instrument. An automatic laser annealing procedure has been implemented by controlling the laser beam position, focus and fluence mirrors, and triggering the laser shots. The block diagram of the computer controlled system is shown in Fig. 3.

3. Standard laser annealing procedure

The standard procedure which will be used to anneal the Nb/Cu 1500 MHz cavity has been successfully tested on a plexiglas model using a HeNe laser. Due to optical constraints in the laser beam steering, only the upper hemisphere of the cavity can be treated in one go. It begins with the initialization of all interface cards and drivers. All five motors are tested by short displacements and subsequently the principle part of the automatic procedure is started. The cavity rotation is kept constant during the treatment, while the repetition rate of the laser shots is varied as a function of the azimuthal angle of the laser beam direction. When this angle is at its maximum preset value, the periscope will be completely withdrawn from the cavity, which can now be lifted, inverted and put back onto the rotary table. Then, the same procedure as before can begin to treat the other hemisphere of the cavity. The entire inner surface is treated in this way by overlapping rings, each of which consists of a string of overlapping laser shots. Variations in the degree of overlap are possible by tuning the timing of the laser trigger with respect to table rotation.

For security reasons, the automatic procedure may be stopped at any time. When this happens, the actual position is recorded so that the treatment can be resumed later.

The laser operating conditions which will be used are 3 J/cm² up to 5 J/cm² fluence, 2 x 2 mm² spot size, 50% overlap and 40 mm/s scanning velocity.

4. Concluding remarks

The ELSA facility has been designed, built, and pre-commissioned at CERN using a pilot laser. The device is operational. This equipment will be now moved to the LAMEL laboratory in Bologna [3], where an XeCl excimer laser is available.

The first phase of the experimental programme consists of the annealing of three Nb/Cu 1500 MHz monocell cavities which have been produced by CERN.

The quality factor of cavities versus accelerating field will be measured before and after the annealing process. First results are expected by end of December 1995.

References

- [1] C. Benvenuti, S. Calatroni, G. Orlandi, *Physica B* **197** (1994) 72
- [2] E. Radicioni *et al.*, *Nucl. Instr. Meth. A* **365** (1995) 28
- [3] CNR-LAMEL, via Gobetti 101, I-40129 Bologna/Italy

1. HeCd laser simulating XeCl excimer laser
2. Beam attenuator
3. Beam homogenizer
4. HeNe pilot laser for alignments
5. Calibrated aperture
6. Joulemeter
7. Fast photodiode
8. Sample holder or 1500 MHz monocell cavity
9. Focusing lens holder and scanning mirror

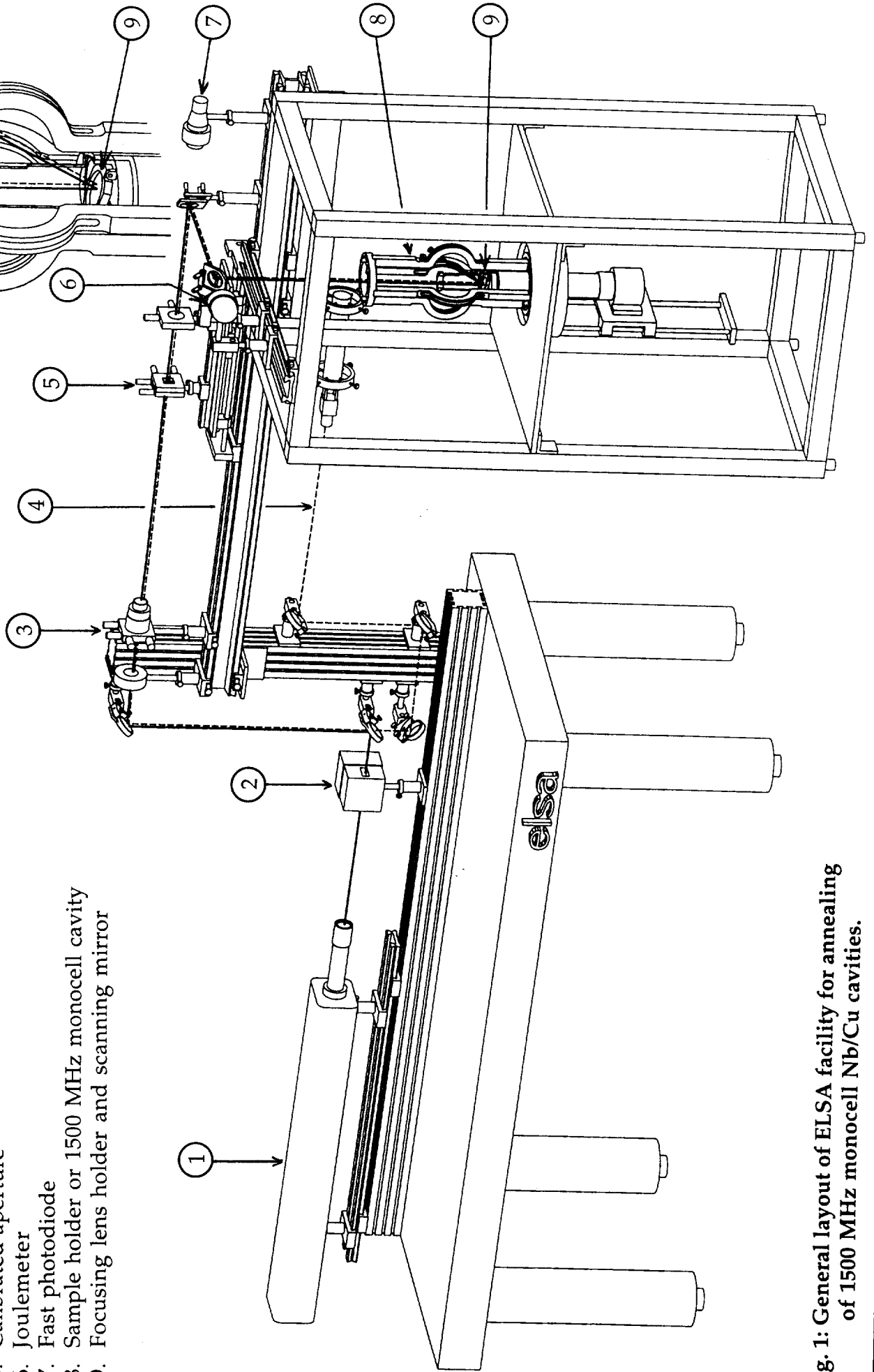
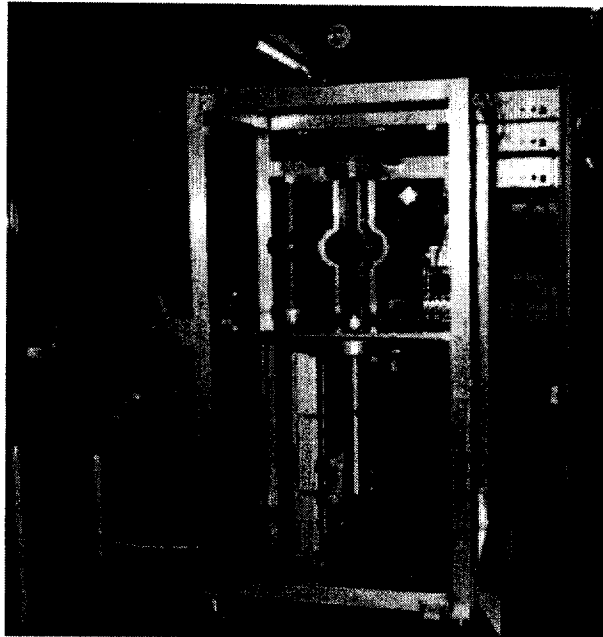
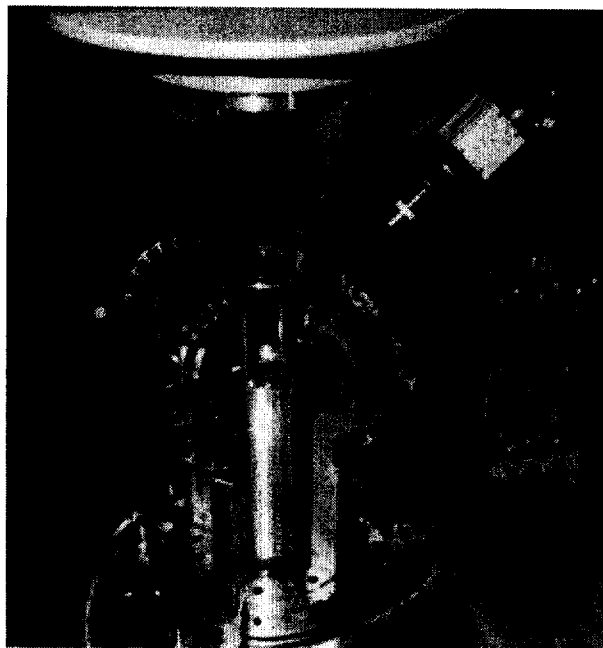

Fig. 1: General layout of ELSA facility for annealing of 1500 MHz monocell Nb/Cu cavities.



a)



b)

Fig. 2: Photographs of ELSA set-up.

a) General view of experimental device.

b) View of sample holder for optical alignments and fluence calibration.

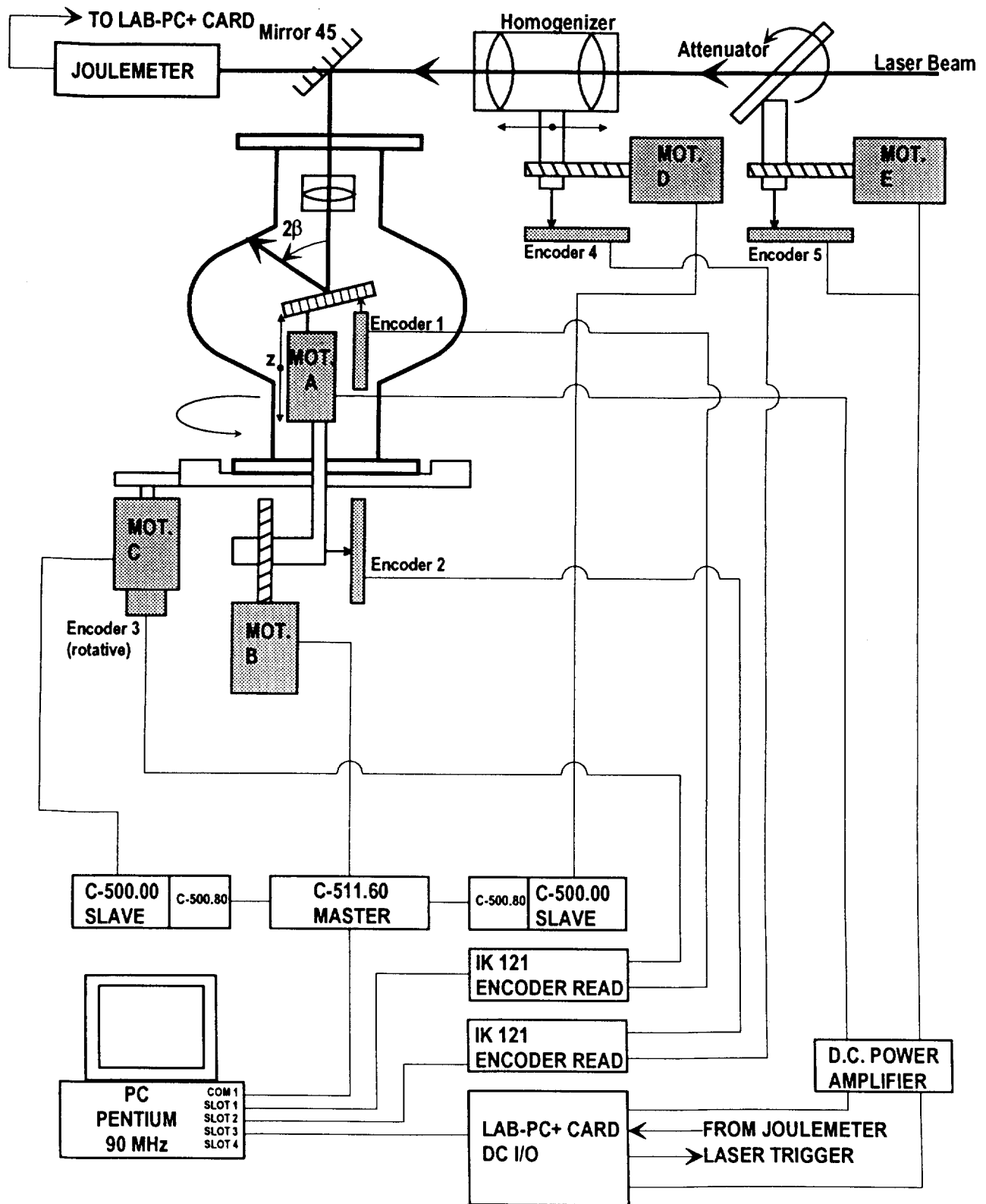

Fig 3: Block diagram of computer controlled system