

LL

Performance Measurements of SLAC's X-band High-Power Pulse Compression System (SLED-II)*

Sami G. Tantawi, Arnold E. Vlieks, and Rod J. Loewen

*Stanford Linear Accelerator Center
Stanford University, Stanford, CA 94390*

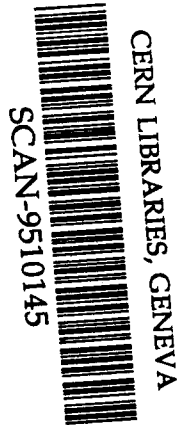

5619543

ABSTRACT

Radio frequency pulse compression using SLED-II [1] is proposed as a method for achieving the high-power flat rf pulse required to drive the Next Linear Collider (NLC) [2]. We describe the experimental procedures and the measurements performed on the high-power X-band SLED-II prototype built at the Stanford Linear Accelerator Center (SLAC). The system uses evacuated room-temperature copper delay lines as a means of storing energy. These lines achieve a quality factor greater than 4.3×10^5 , with total losses due to external components measured at 4%. We compare our experimental results with theory.

Submitted for publication in *IEEE Microwave and Guided Wave Letters*

* Work supported by Department of Energy contract DE-AC03-76SF00515.

INTRODUCTION

The SLED-II pulse compression system provides a method for enhancing the peak output power of rf sources while at the same time producing a flat output pulse shape. In order to achieve pulse compression, energy from an incoming rf pulse is stored in high Q resonant delay lines. While charging, energy that leaks out of the delay lines is, to great extent, canceled by the reflected incident rf. To discharge the lines, the phase of the incoming pulse is reversed so that the reflected signal from the inputs to the lines adds constructively with the emitted field from the stored energy in the lines for the duration of one round trip time of rf in the line.

The system suffers from two types of losses that reduce its efficiency: intrinsic losses and finite conductivity losses. By design, some of the input energy is immediately reflected at the delay line entrance during the charging phase. Additionally, after the phase reversal, the energy inside the lines is not discharged completely at the desired compressed pulse time period. Unfortunately, the coupling coefficient to the line that maximizes the energy storage makes the energy discharge from the line far from optimum. For optimum coupling coefficients at different compression ratios the reader is referred to [1]. During the period of time the rf energy spends inside the storage line part of it is lost simply due to the finite quality factor of the lines. Similar losses occur from the finite conductivity of the components used to manipulate the input and output signals.

In this paper we describe the SLED-II system constructed at SLAC. We report the experimental procedures used to measure the storage line quality, the coupling coefficient to the lines, and component losses. We also summarize the system's overall performance.

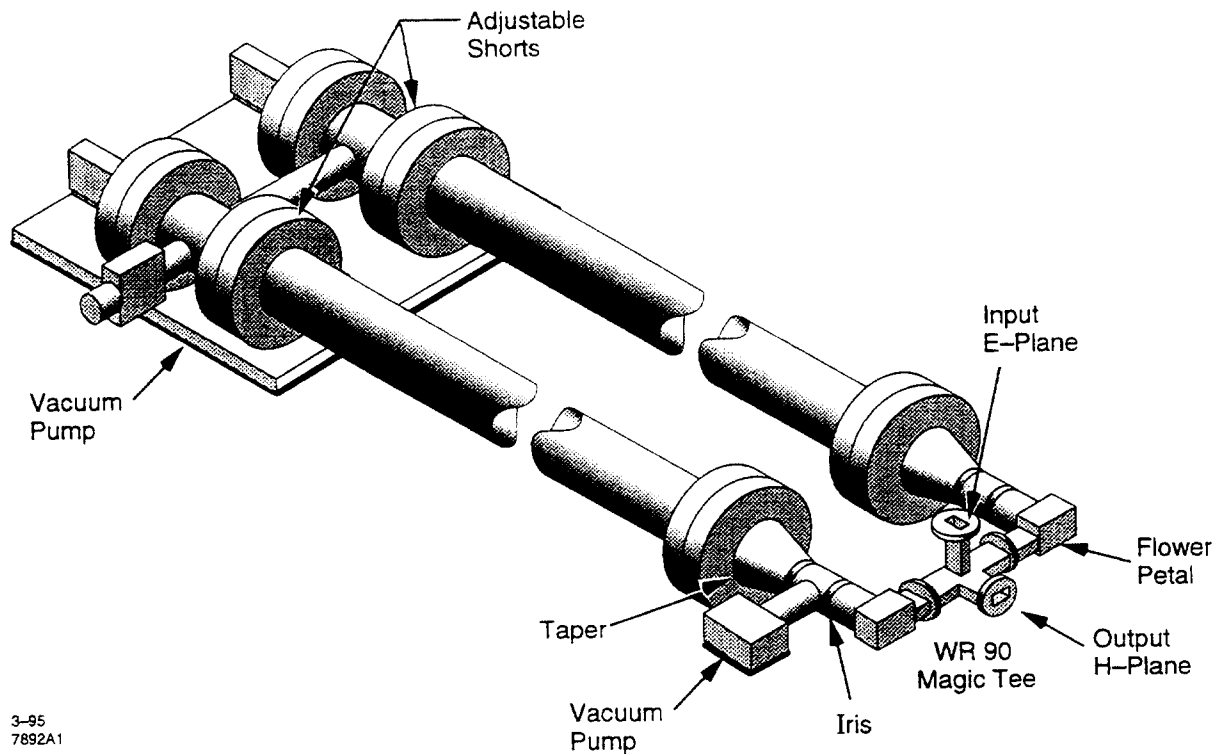

3-95
7892A1

Figure 1. SLED-II layout. Tested with 12.065 cm diameter waveguide, 22.5 m in length (150 nS round-trip rf transit time.)

THE SLED II EXPERIMENT

Figure 1 shows the pulse compression system. It uses two 22.5-meter long cylindrical copper waveguides as delay lines, each 12.065 cm in diameter and operating in the TE_{01} mode. In theory, these over-moded delay lines can form a storage cavity with a quality factor $Q > 1 \times 10^6$. Each of the delay lines is terminated by a shorting plate whose axial position is controllable to within $\pm 4 \mu\text{m}$ by a stepper motor. The input of the line is tapered down to a 4.737 cm diameter waveguide at which the mode TE_{02} is cut-off; hence, the circular irises which determine the coupling to the lines do not excite higher order modes provided that they are perfectly concentric with the waveguide axis. A compact low loss mode converter excites the TE_{01} mode just before each iris. These mode transducers—known as *flower-petal mode converters* [3]—were developed specifically for this

application. Both mode converters are connected to the coplanar arms of a high-power WR 90 magic tee [3]. The arms differ in length by a quarter wavelength at the operating frequency of 11.424 GHz. Therefore, the reflection from the lines exits through the H-arm when the input to the lines enters from the E-arm. The distance from the irises to the center of the magic tee has been adjusted to within $\pm 13 \mu\text{m}$ to maximize this transmission.

MEASUREMENTS SETUP

All measurements were performed using an HP8510C network analyzer with the results examined in the time domain using a PC. The frequency domain measurements were transferred to the PC via a GPIB link and multiplied by the FFT of a maximally flat pulse modulating an 11.424 GHz signal. If we define the compressed pulse width as t_d (equal to the round trip time of the rf through the delay line), the input pulse width should be of the form $C_r t_d$, where C_r is an integer equal to the compression ratio. For a given compression ratio, the phase of the input pulse should be reversed 180° at the time $t_d (C_r - 1)$. In our case the value of t_d is fixed at 150 nS. The test pulse has the following form:

$$V_{in}(t) = \frac{1}{\sqrt{1 + \left(\frac{2t}{t_d C_r}\right)^{2n}}} - \frac{2}{\sqrt{1 + \left(\frac{\left[t - \frac{t_d(C_r - 1)}{2}\right]}{t_d}\right)^{2m}}} \quad (1)$$

where n controls the pulse rise time and m controls the phase reversal rise time. The time domain output is produced by taking the IFFT of this frequency domain product. Note that once we obtain the frequency characteristics of the system from the network analyzer, we can calculate the time domain response for any arbitrary input pulse.

Experimental Methods and Results

In order to determine the rf losses of the magic tee/mode transducer assembly, the circular end of the mode transducer was shorted and the round trip transmission was measured to be greater than 97%. The reflections from the input and output ports was also measured to be less than -30 dB. The delay lines were then attached and brought into resonance at 11.424 GHz with the adjustable shorts. Figure 2 shows the measured frequency response of the system. Figure 3 shows the response of the system to a pulse described by Eq. (1) for a pulse width of 1.2 μ S (a compression ratio of 8). The power gain of the compressed pulse is given [1] by

$$\text{Power Gain} = \left[R_0 + (1 - R_0^2) \frac{1 - (R_0 p)^{C_r - 1}}{1 - R_0 p} p \right]^2 (1 - x) \quad (2)$$

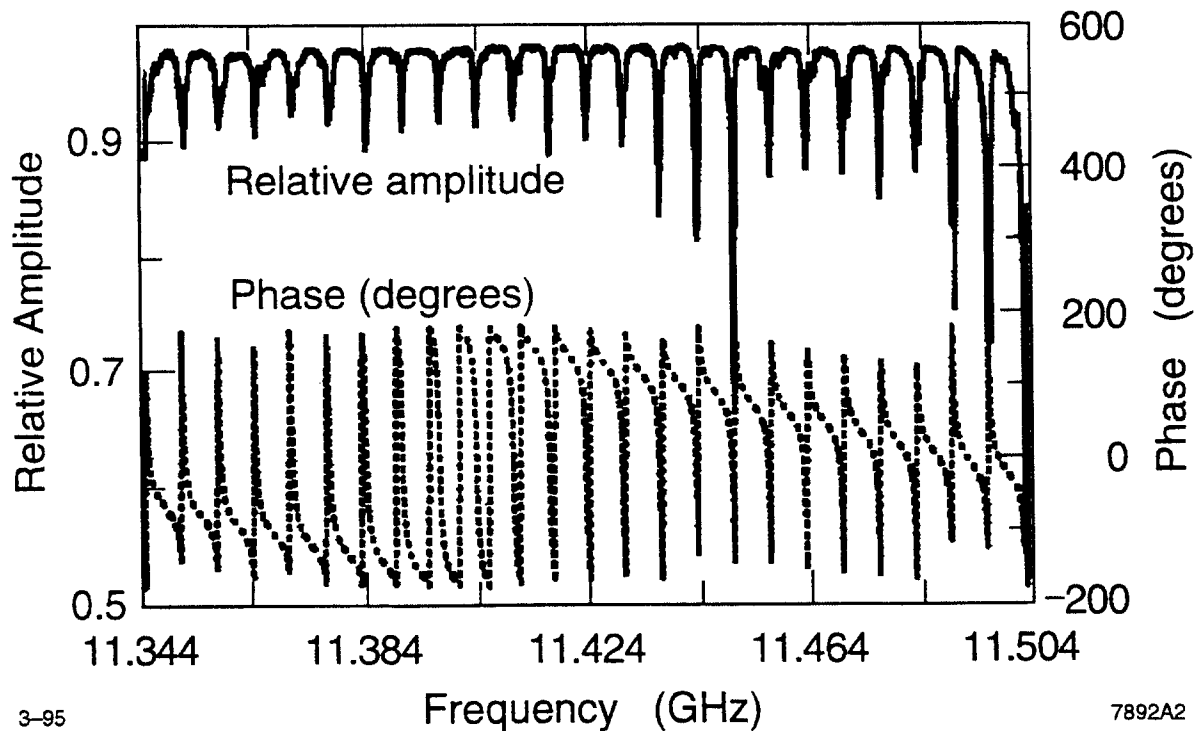

Figure 2. SLED-II measured frequency response in magnitude and phase.

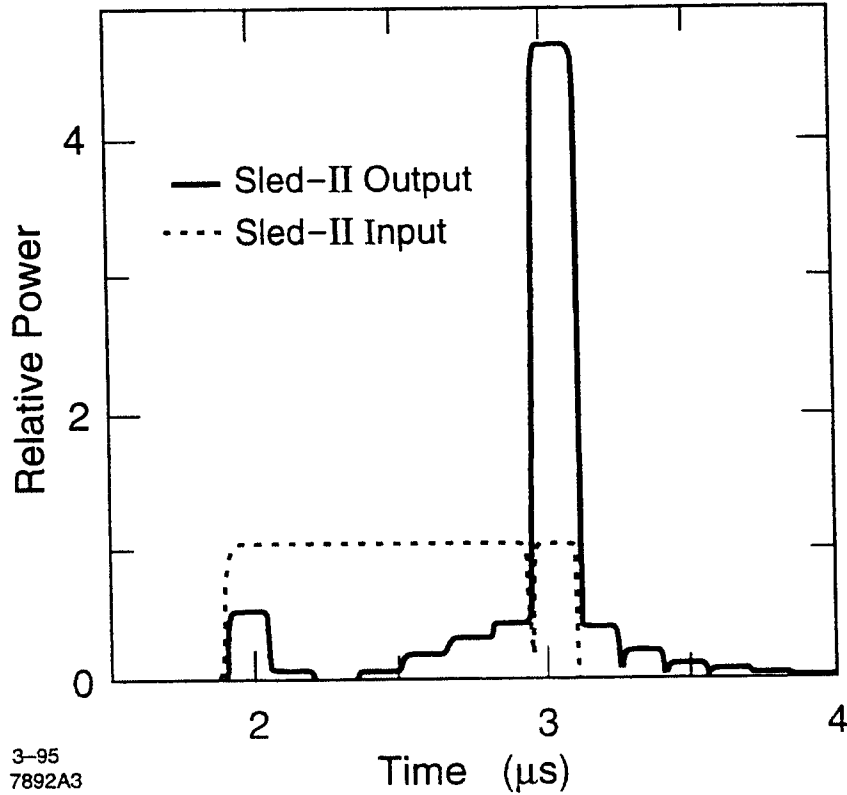

Figure 3. SLED-II output for a compression ratio of 8: input pulse width = 1.2 μ S and output pulse width = 0.15 μ S.

where R_0 is the iris reflection coefficient, x is the power losses due to external components (the magic tee/mode transducer assembly), and $(1 - p^2)$ are the round trip losses in the transmission lines. This last quantity is related to the intrinsic quality factor of the line [1] by:

$$Q = \frac{\pi f_0 t_d}{-\ln(p)} \quad (3)$$

The power gain was measured for a series of compression factors. A least-squares fitting of these measurements to Eq. (2) with the fit parameters R_0 , x , and $(1 - p^2)$ is shown in Figure 4. The round trip losses was found to be 2.45%, indicating an intrinsic Q for the lines of $4.3 \cdot 10^5$. The external losses are 4%, and the iris reflection coefficient is 0.74. The iris was designed using a mode matching code to have a reflection coefficient of 0.73, the optimum value for a compression ratio of 8.

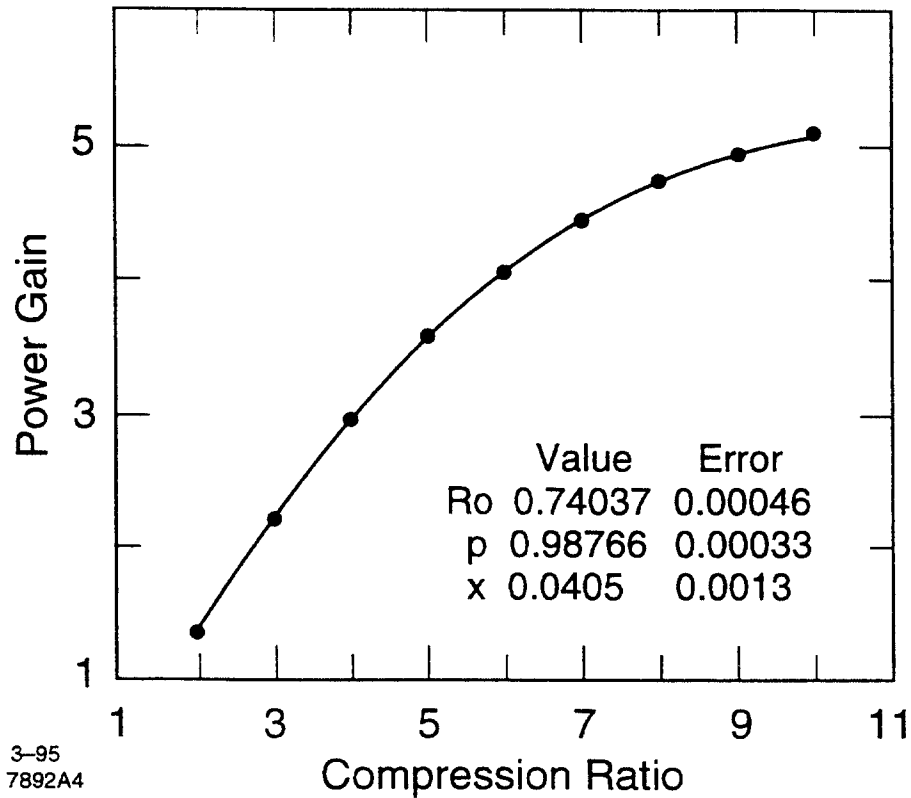

Figure 4. The points are measured power gains for different compression ratios. The curve represents the least-squares fit for the parameters in Eq. (2) with values as shown.

Conclusion

We characterized the performance of the SLED-II pulse compression system built at SLAC and found the storage line Q to be 4.3×10^5 . In theory the number can be greater than 1×10^6 if one assumes a true circular waveguide perfectly excited in the TE_{01} mode. In reality, the waveguides deform over this long length. Furthermore, the mode transducers are not ideal and contain mode impurities [2] of approximately 0.5% in power. The external losses, although measured separately to be less than 3%, increased to 4% in the complete system. This difference occurs since the mode transducers output different mode structures depending on their connection to either a shorting plate or to the iris and delay line combination

Acknowledgment

The authors thank Prof. Ronald D. Ruth, Dr. Z. D. Farkas, Prof. P. Wilson, Dr. C. Nantista, and Prof. N. Kroll for many useful discussions. We thank C. Yoneda, and A. Menegat for their effort in the assembly of this experiment.

REFERENCES

- [1] P. B. Wilson, Z. D. Farkas, and R. D. Ruth, "SLED II: A New Method of RF Pulse Compression," Linear Accelerator Conference, Albuquerque, NM, September 1990; SLAC-PUB-5330.
- [2] R. D. Ruth et al., "The Next Linear Collider Test Accelerator," Proceedings of the IEEE Particle Accelerator Conference, Washington DC, May 1993, p. 543.
- [3] S. G. Tantawi et al., "Numerical Design and Analysis of a Compact TE₁₀ to TE₀₁ Mode Transducer," Conference on Computational Accelerator Physics, Los Alamos, NM, 1993, AIP Conference Proceedings 297, pp 99-106.