

DD

E13-95-20

J.Budagov, I.Chirikov-Zorin, G.Chlachidze¹, V.Kolomoets,
Yu.Kulchitsky², A.Lebedev, Yu.Lomakin, S.Malyukov,
D.Pantea³, L.Permjakova, V.Romanov, N.Russakovich,
A.Shchelchkov, A.Sissakian, V.Teterin, N.Topilin, V.Utkin

ATLAS BARREL HADRON
CALORIMETER MODULE DESIGN

CERN LIBRARIES, GENEVA



SCAN-9506090

SW9525

¹On leave from Institute of High Energy Phys. TSU, Tbilisi, Georgia

²On leave from Academy of Science, Minsk, Belarus

³On leave from Institute of Atomic Physics, Bucharest, Romania

1. INTRODUCTION

The 6 meter module design version was presented by us on *October 13th 1994 CERN ATLAS week*. The module design option presented here is a modification of the above mentioned design version.

The module design changing were introduced to obtain the all collaboration acceptable design.

2. SUBMODULE DESIGN DESCRIPTION

The submodule is presented on Fig. 1.

The master and absorber plates are glued between themselves by epoxy glue.

One module consists of 19 submodules.

Total module's amount of periods is equal to 311.

12 submodules have 16 periods and 288 mm of thickness; 7 submodules have 17 periods and 306 mm of thickness.

Each submodule length tolerance is ${}^{+0.00}_{-0.25}$ mm.

On the submodule's narrow side along its length 2 strips are welded (10×30 mm² in cross-section) (Fig. 2) and also the key way is foreseen of $10 \times 125^{+0,1}$ mm² dimensions.

Strips have 4 holes M12 for connecting of the ringing auxiliary equipment and it is positioned above the submodule's side surface on 1 mm. In the submodule wide side along its length the 30×47 mm² (cross section) strips are welded (Fig. 3) and also there is 10×180 mm² cross-section key way. These strips have 4 M20 holes for the submodule connection to the girder. The strips are 3 mm sank relatively to submodule's inclined surfaces and therefore do not disturb the fibers stuffing when module final assembly.

3. MODULE DESIGN DESCRIPTION

The detailed module design is illustrated by Fig.'s 4 ÷ 6.

The girder is the main module force element. The edges of the girder are forced by 40 mm thick flanges plates (see Fig. 4). Plates are welded to girder's longitudinal elements by T-like welds. The weld's cathets are 10 mm. Total length of welds — for one plate — is 580 mm. The plates have on their each side $\varnothing 50$ mm half-holes (Fig. 5) for $\varnothing 50 \times 40$ mm² pins placing when barrel assembling. Along all its length the girder

has $10 \times 180 \text{ mm}^2$ cross-section projection (Fig. 6). When module assembling the submodules will be placed --- by their key ways --- on that projection and then fixed by M20 bolts to the girder.

In the module narrow side, into the submodules $10 \times 125 \text{ mm}^2$ the key ways (the strip clamping) are inserted and after that welded (Fig. 7). At the module's ends two edge submodules are covered by end-plates. End-plates are attached to edge submodules by M12 bolts (Fig. 8) and than welded to the strip clamping. Module is penetrated by $\varnothing 6 \text{ mm}$ 11 tubes and by 11 studs of $\varnothing 6 \text{ mm}$ in diameter. The tubes are needed for radiative source moving when tiles tests.

After 6 m module is assembled the strips side surfaces are machining (Fig. 7) in order to obtain the flat contact surface. In the internal barrel volume the modules are contacting along the strips side surfaces. In the outside barrel part the modules are contacting through girder. There is no contact between the neighboring modules master plates.

4. MODLE ASSEMBLY GENERAL TOOLING DESIGN DESCRIPTION

The module assembling is done with special tooling use (Fig. 9). This tooling consists of: 6 orthagonal I-beams 240 mm high; two structural channels 140 mm high; ribs of stiffness 6 mm thick and of supporting plates 20 mm thick.

All elements of tooling are welded between themselves. The tooling's length is equal to the module's one. The bottom surfaces of tooling and the supporting surfaces of it are milled.

The top supporting surfaces have $\varnothing 27 \text{ mm}$ holes to fix the girder when module assembling. The weight of tooling described is about 1000 kG; production cost is near 2000\$.

5. MODULE ASSEMBLY MAIN STAGES

Before the assembling the tooling (Fig. 9) is located on the steel floor. The upper girder's supporting plane horizontality is not worse then $\pm 0.1 \text{ mm}$. To the tooling will be attached and fixed the girder (Fig. 10).

The horizontality of girder's surface "K" (to place submodule on) is not worse $\pm 0.1 \text{ mm}$. The edge submodule is placed on girder together

with submodule flange plate (end plate). The submodule vertical position is checked by level gauge. Non perpendicularity of submodule positioning is allowed to be not worse than $\pm 20''$ (or ± 0.15 mm).

If necessary the submodule's vertical position can be adjusted by inserting of the shim between the girder and the submodule.

Then to the first submodule with corresponding shims will be positioned --- one by one --- the next submodules. The shim thickness can not be more than 0.5 mm. The total Z-direction shims thickness can not be more than 5 mm. When positioning each submodule must be pressed to the previous one by 4 tons force by means of clamping device and jacks (Fig. 10) and then submodules are fixed by M20 bolts.

The each submodule verticality is checked and corrected in the same manner it was done for the first module.

After all submodules were positioned in the upper key way will be inserted the strip clamping with 10×125 mm² cross-section and 5640 mm length. By M12 studs the strip clamping through the cover plate (Fig. 11) is pressed to the submodules (Fig. 12) and is welded to the module. The welds on the strip clamping edges will be done alternatively on different sides each time with weld length $\simeq 50$ mm. This method prevents significant deformations of the strip clamping and of module due to welding seams influence.

After module assembly is completed the strips side surfaces are machined (Fig. 7) in order to obtain the plane contact surface.

Module is grounded and painted to prevent it against corrosion.

6. THE MODULE SLINGING, PACKING AND TRANSPORTING

After assembling the module is removed from the assembly support. The cross rail and brackets are used for its lifting (Fig. 13). Each bracket is fasten to a submodule by four bolts M12 (Fig. 14). The weight load of the module is distributed uniformly between all brackets and bolts.

After lifting and moving the module is installed vertically on two supports (Fig. 15, 16). In such position it can be stored, assembled and transported by rail or car.

To turn a module around the Z-axis two brackets are installed on a girder (Fig. 13). The module is connected by two axles to a support

(Fig. 17). After lowering of a crossrail the module is rotated and installed on the support in a horizontal position. For the subsequent lifting of a module two additional brackets are installed on it (Fig. 13, 18). The use of such scheme of slinging makes possible to assemble the first half of a barrel.

For the assembly of the second half of barrel the angular bracket is installed on the module along all its length (Fig. 19, 20). The angular bracket are fastened by bolts M24 to a girder. Such scheme of a slinging permits us to install the modules in barrel after the installation of a cryostat.

The bend of a module along its length is absent when such angular bracket is used for the lifting and moving of the module. This is due to the fact that the angular bracket takes the module's load uniformly along its length.

Changing the installation place of the mobile brackets we get the necessary rotation angle of the module around of the Z-axis (Fig. 21, 22). In all cases mentioned above the tensions and deformations of the module will be much less than allowable ones.

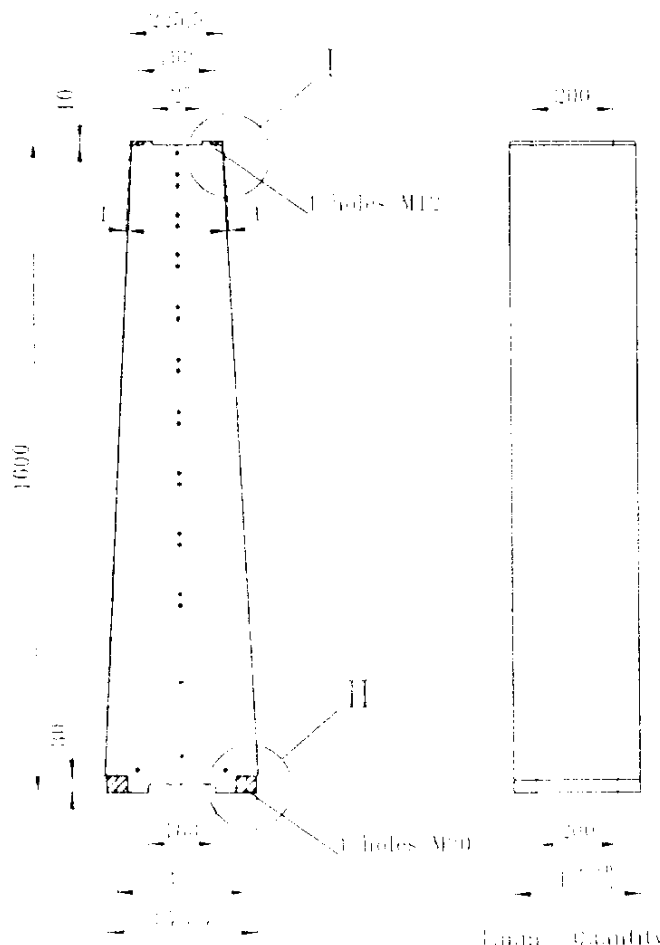

	Unit	Quantity
Submodule N1	300	12
Submodule N2	300	7
Total	1600	19

Figure 1

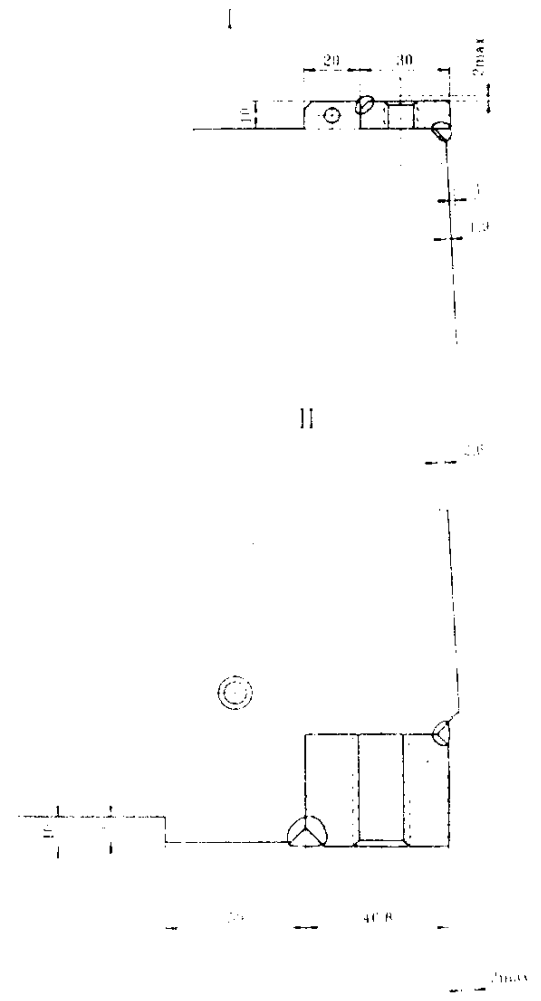

Figure 2 & Figure 3

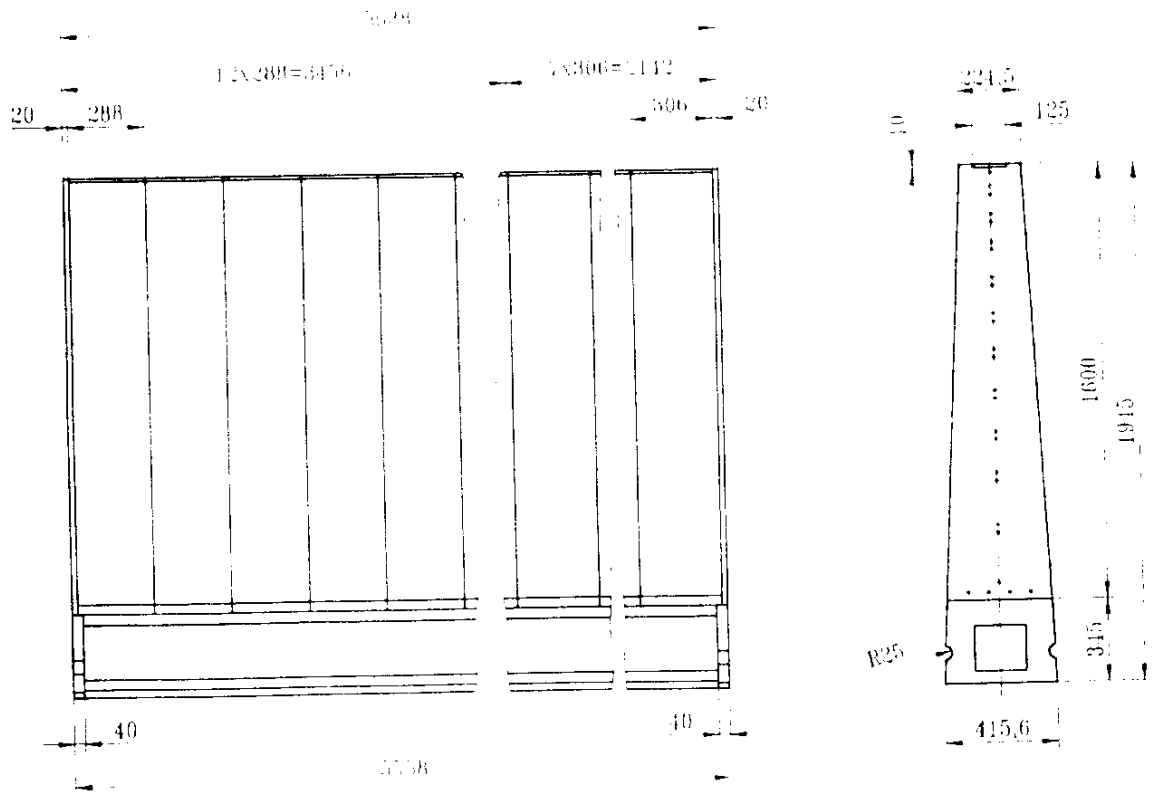

Figure 1

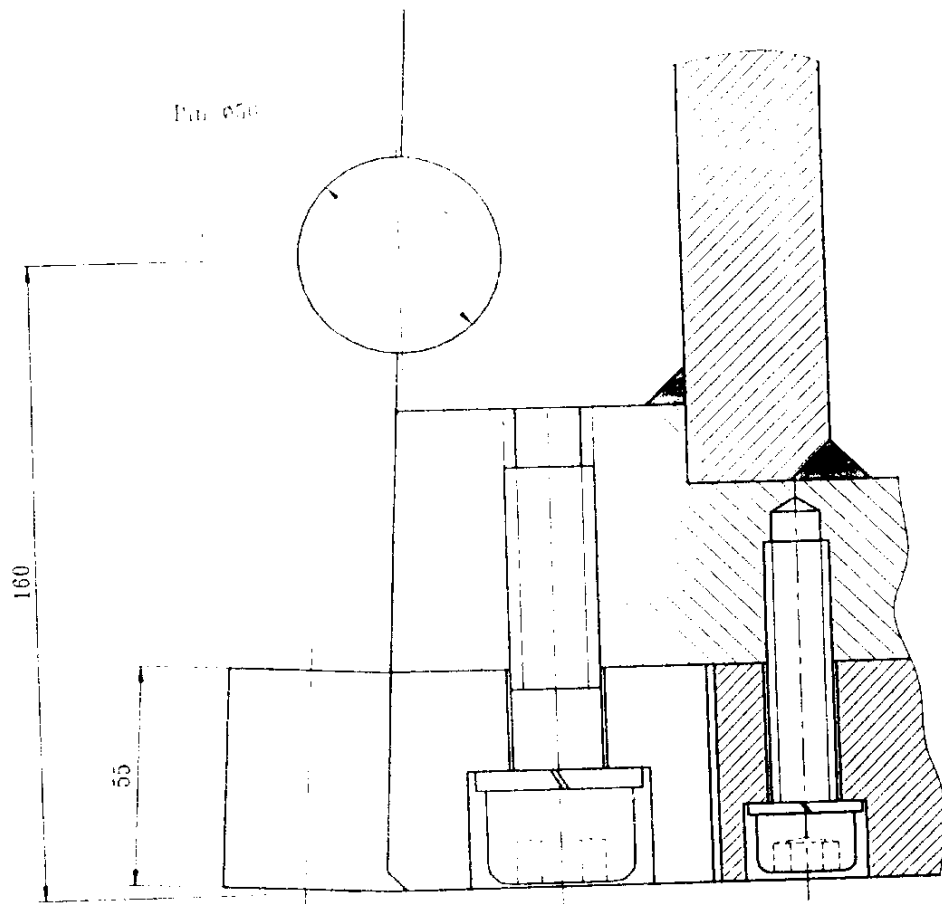

Figure 2

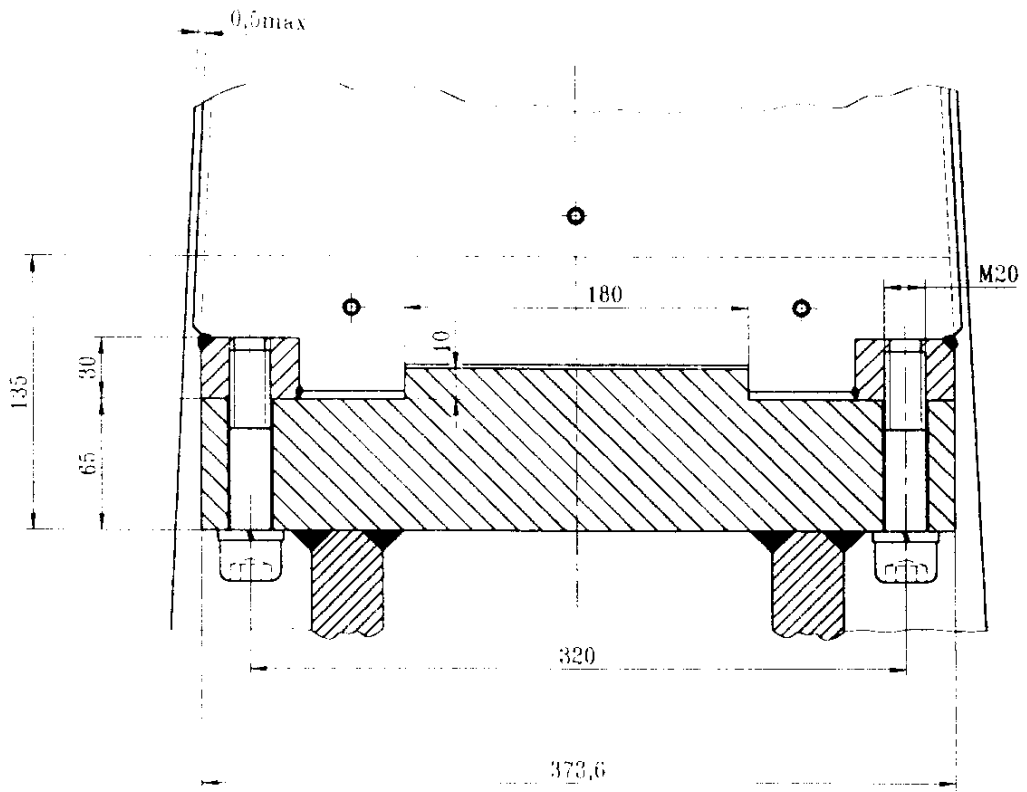

Figure 6

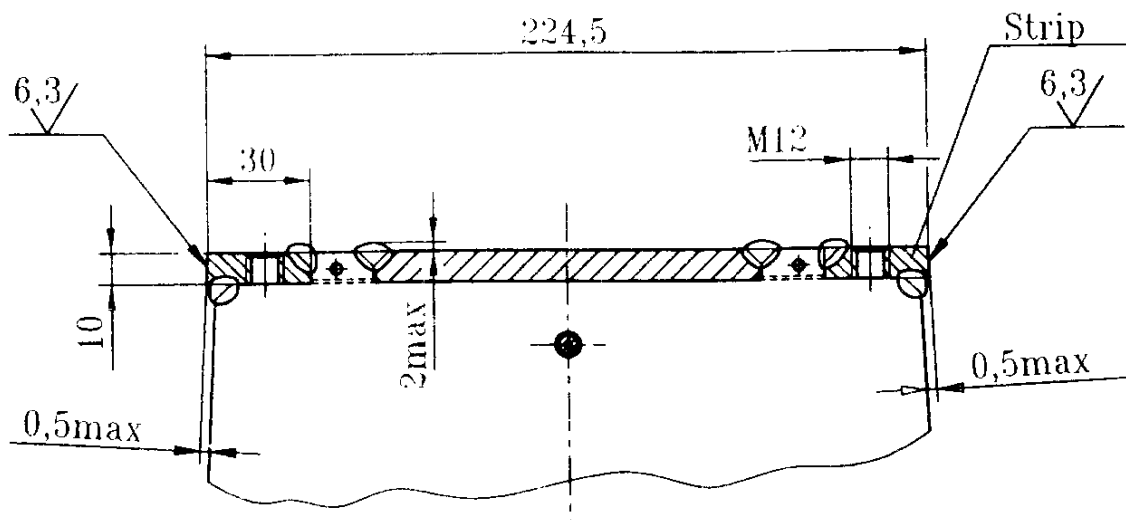

Figure 7

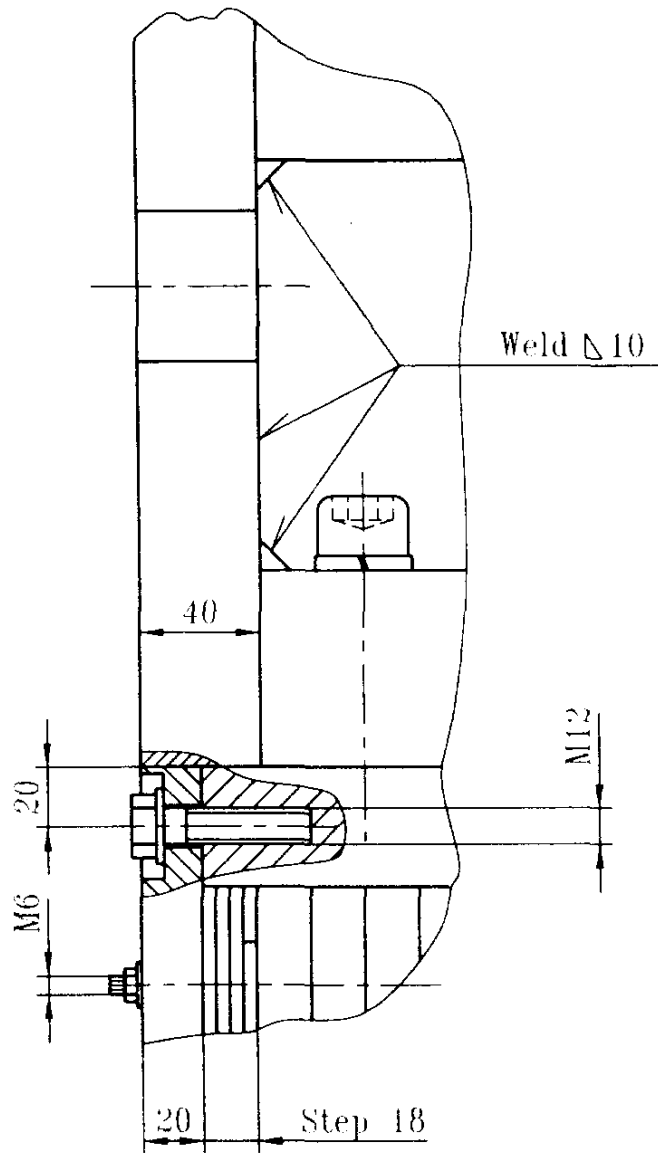

Figure 8

Weight 1000kG

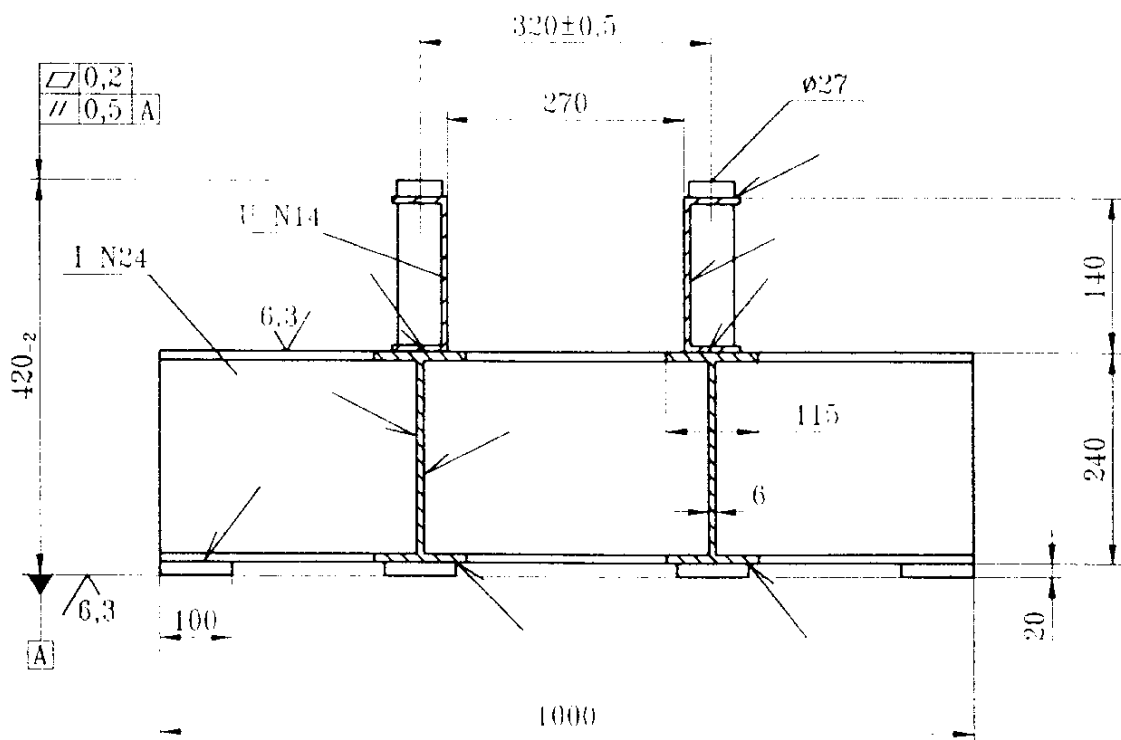

Figure 9

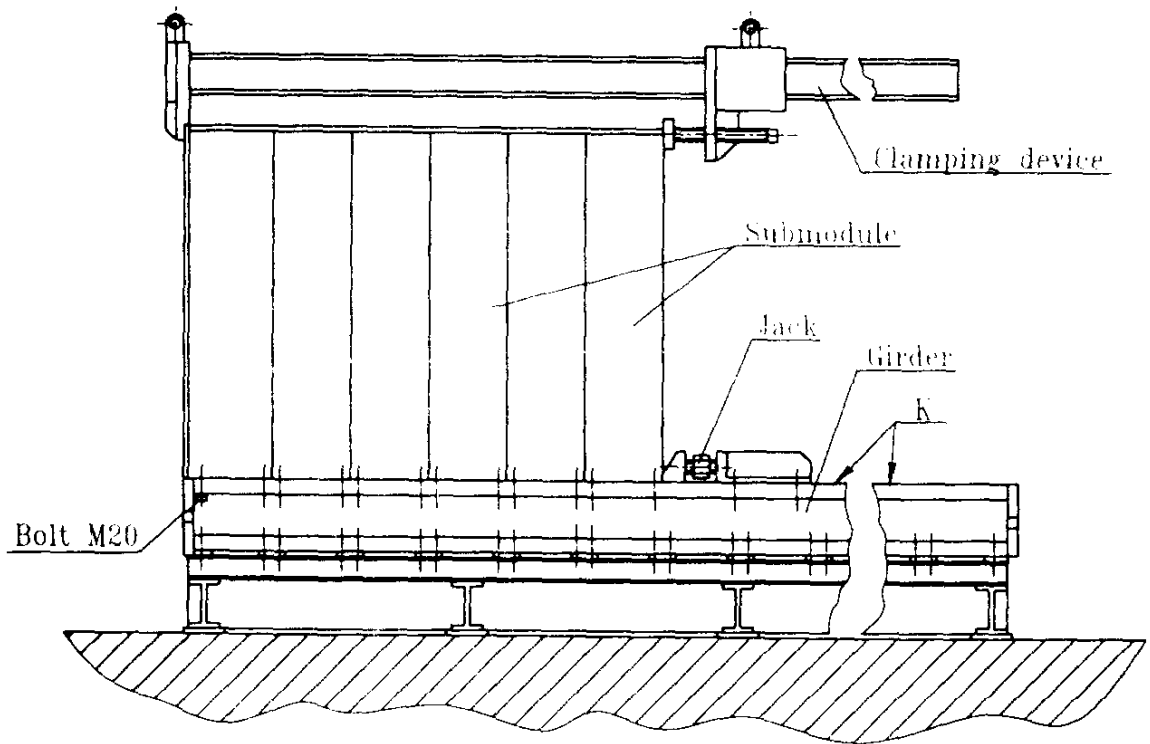

Figure 10

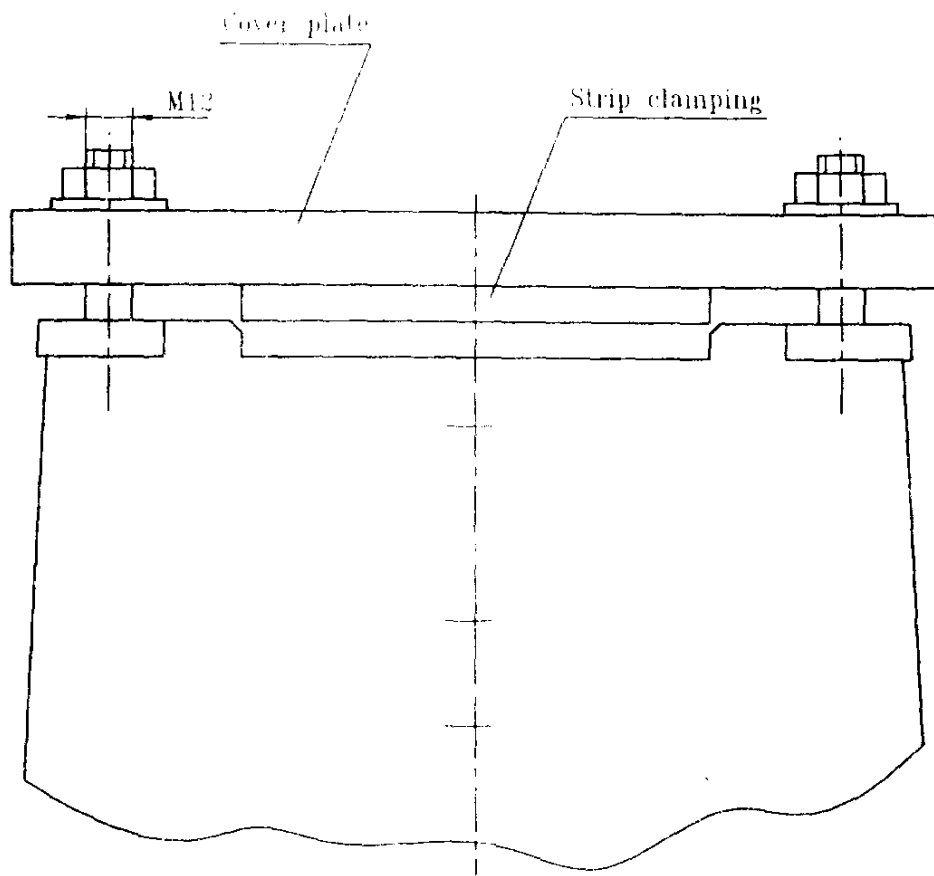

Figure 11

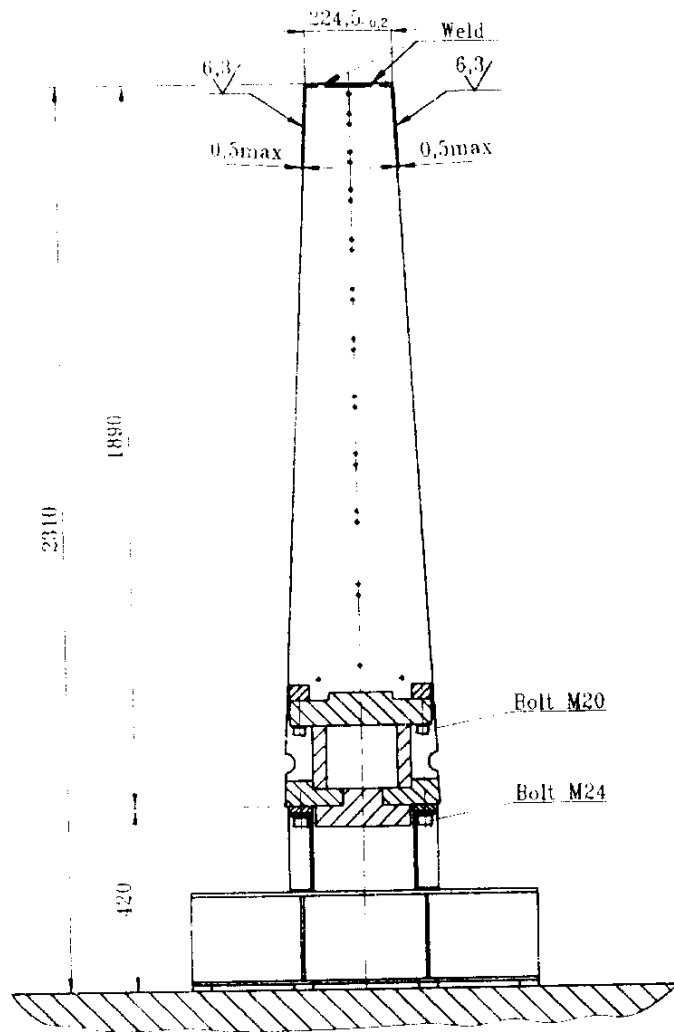

Figure 12

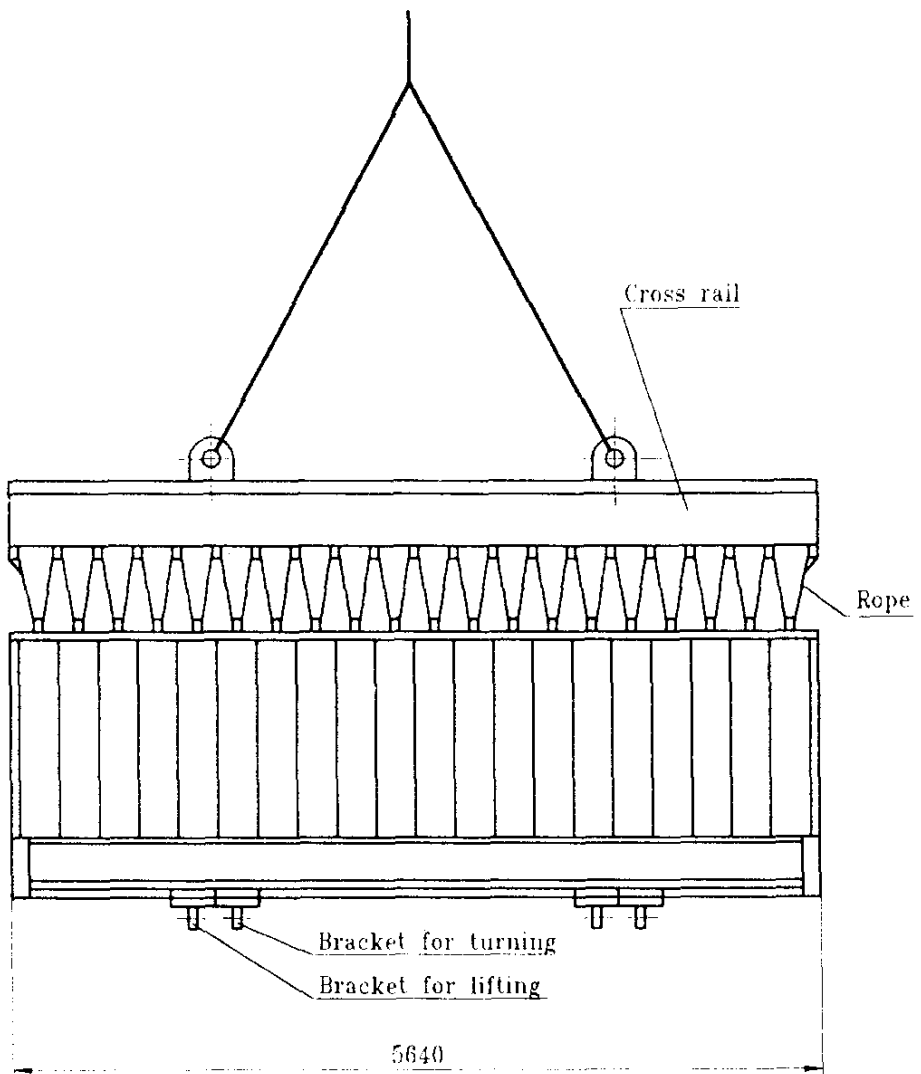

Figure 13.

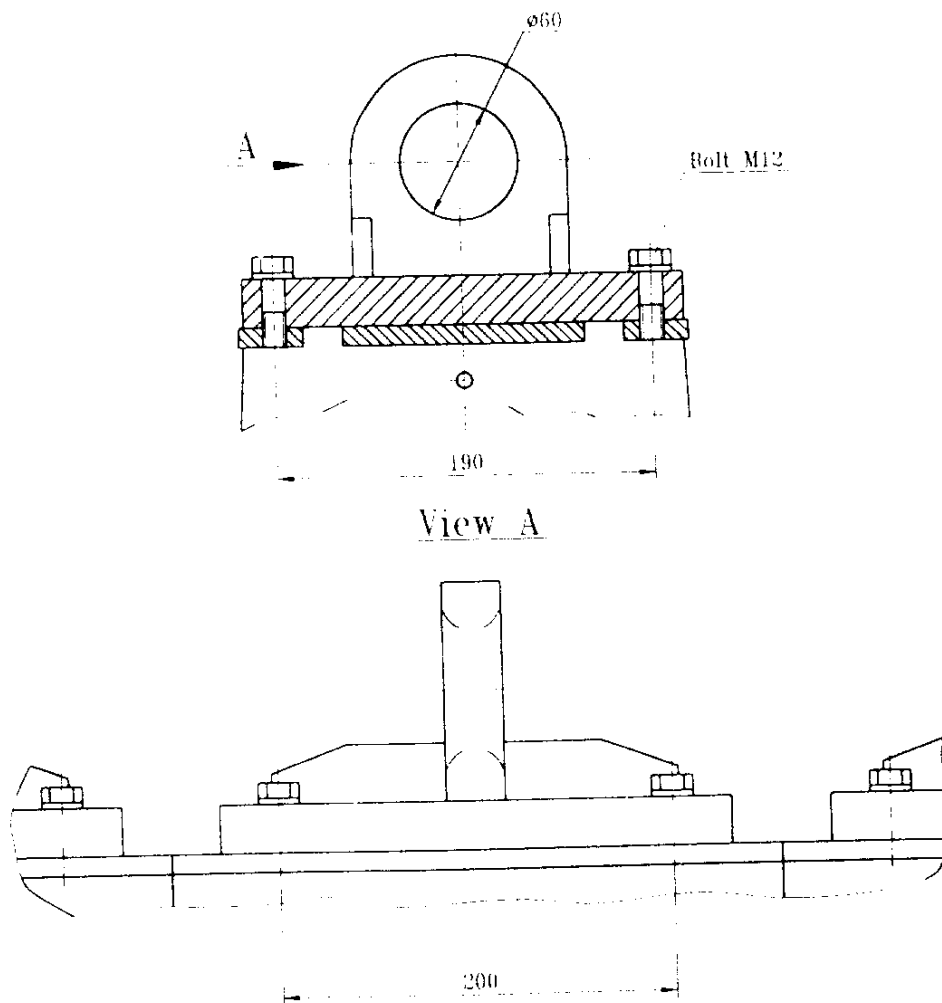

Figure 14

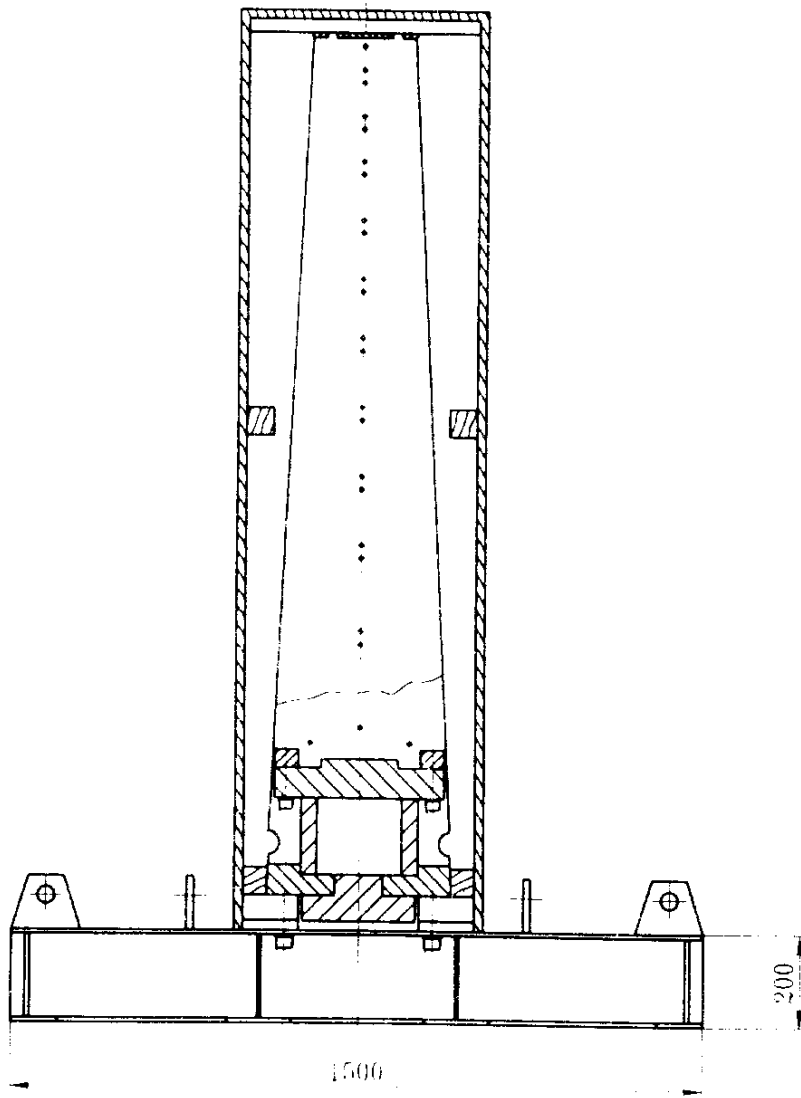

Figure 1b

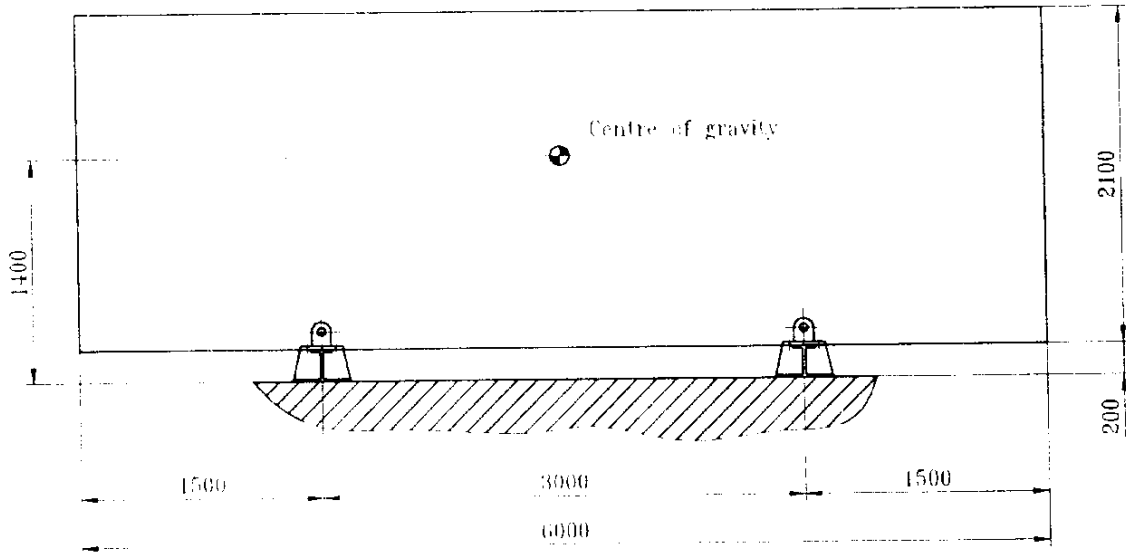

Figure 16

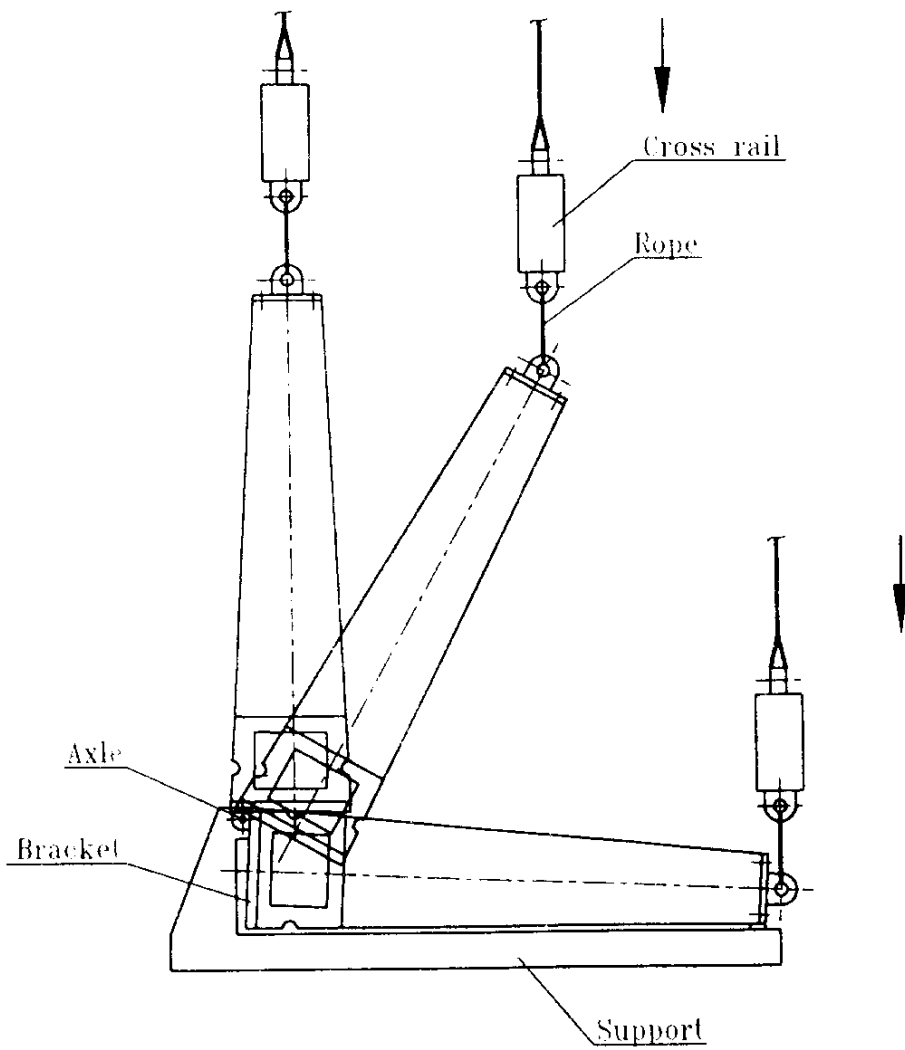

Figure 17

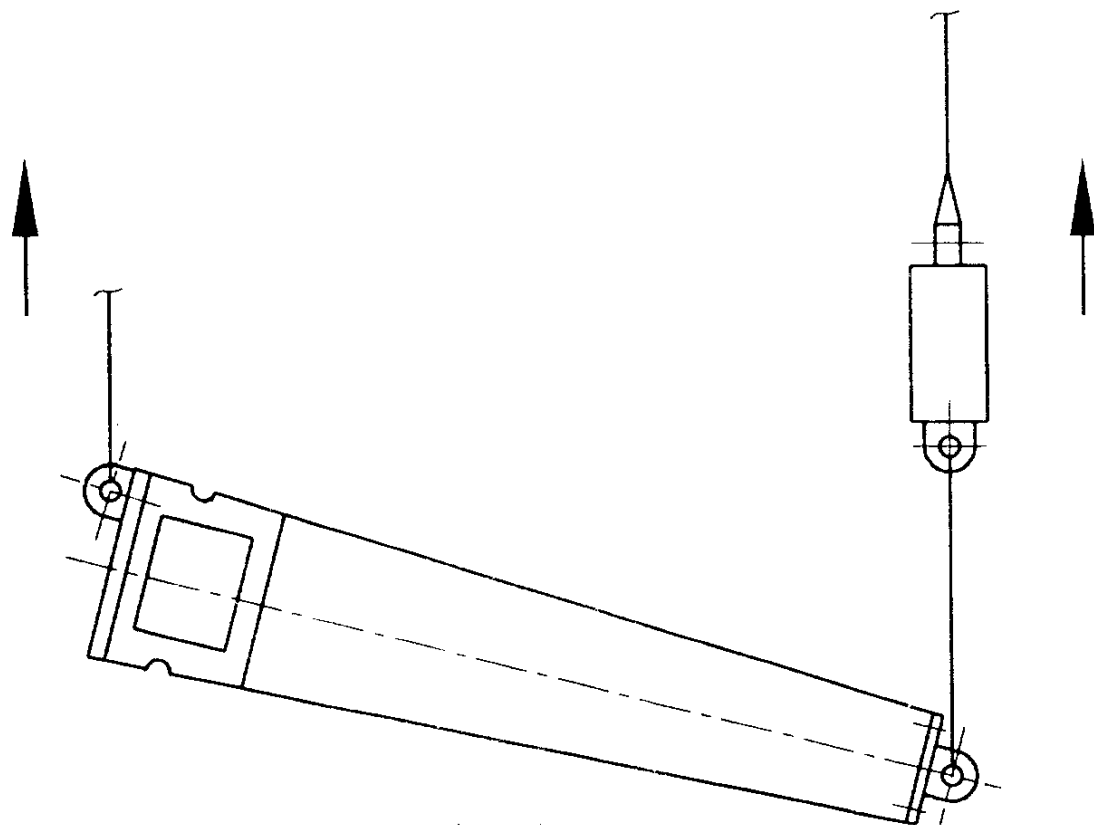

Figure 18

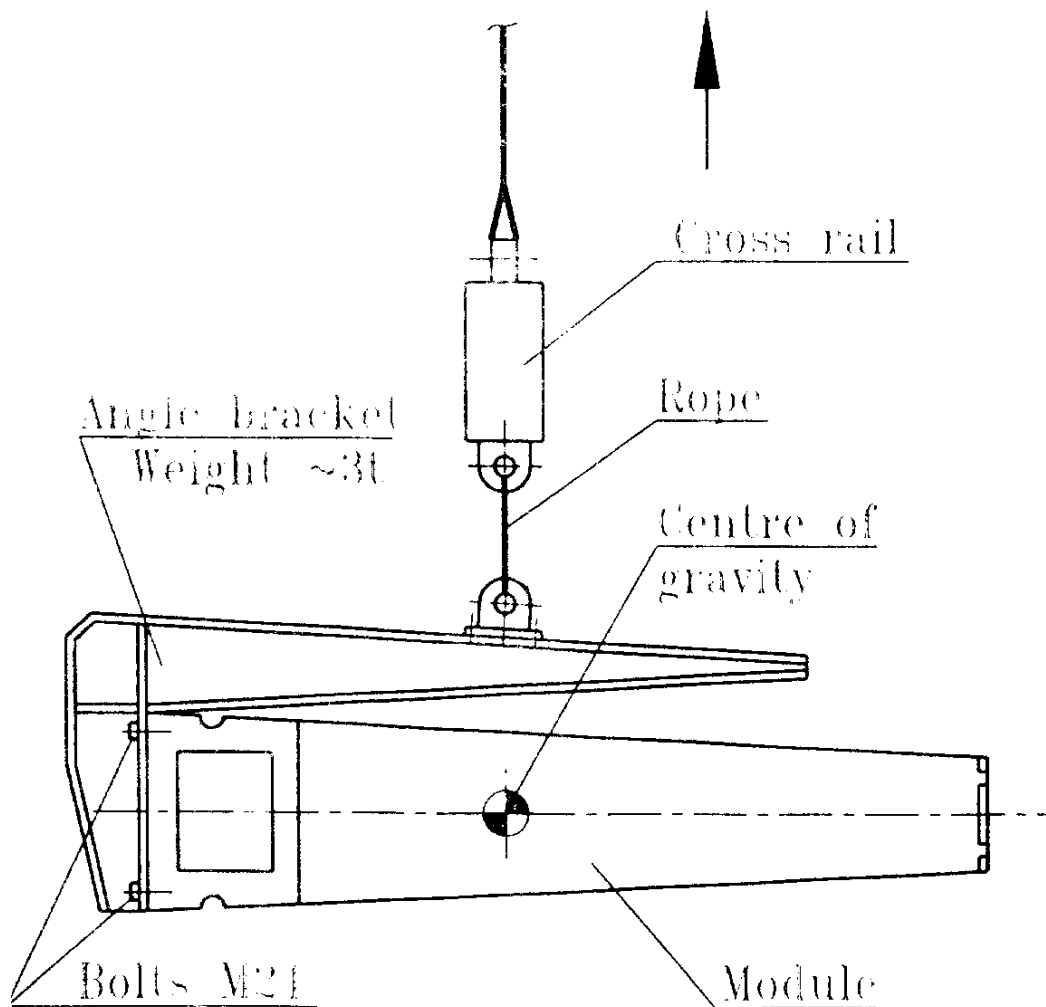

Figure 19

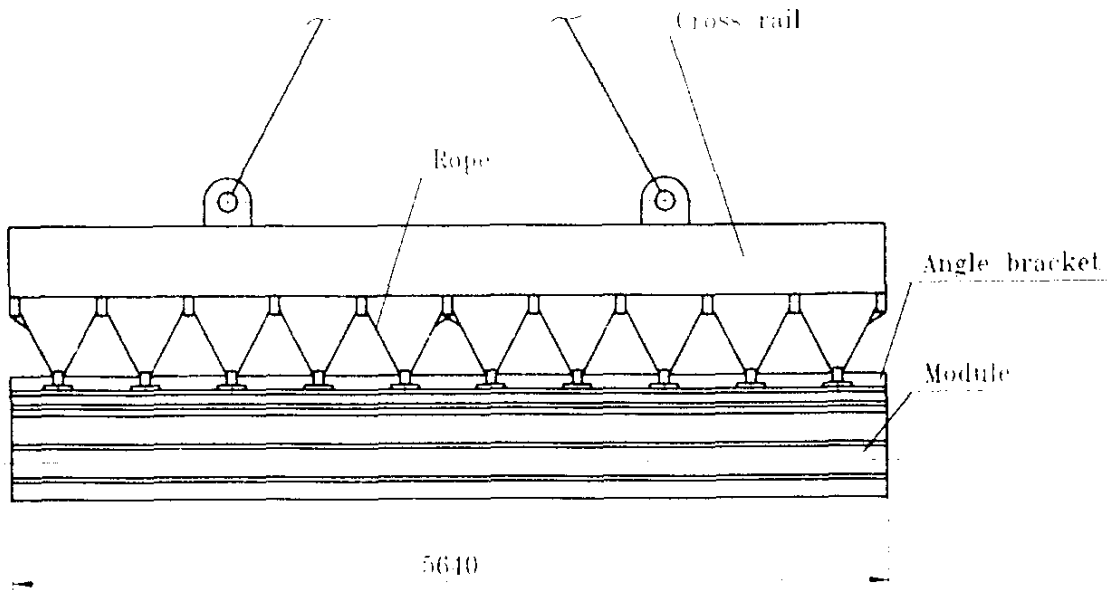

Figure 20

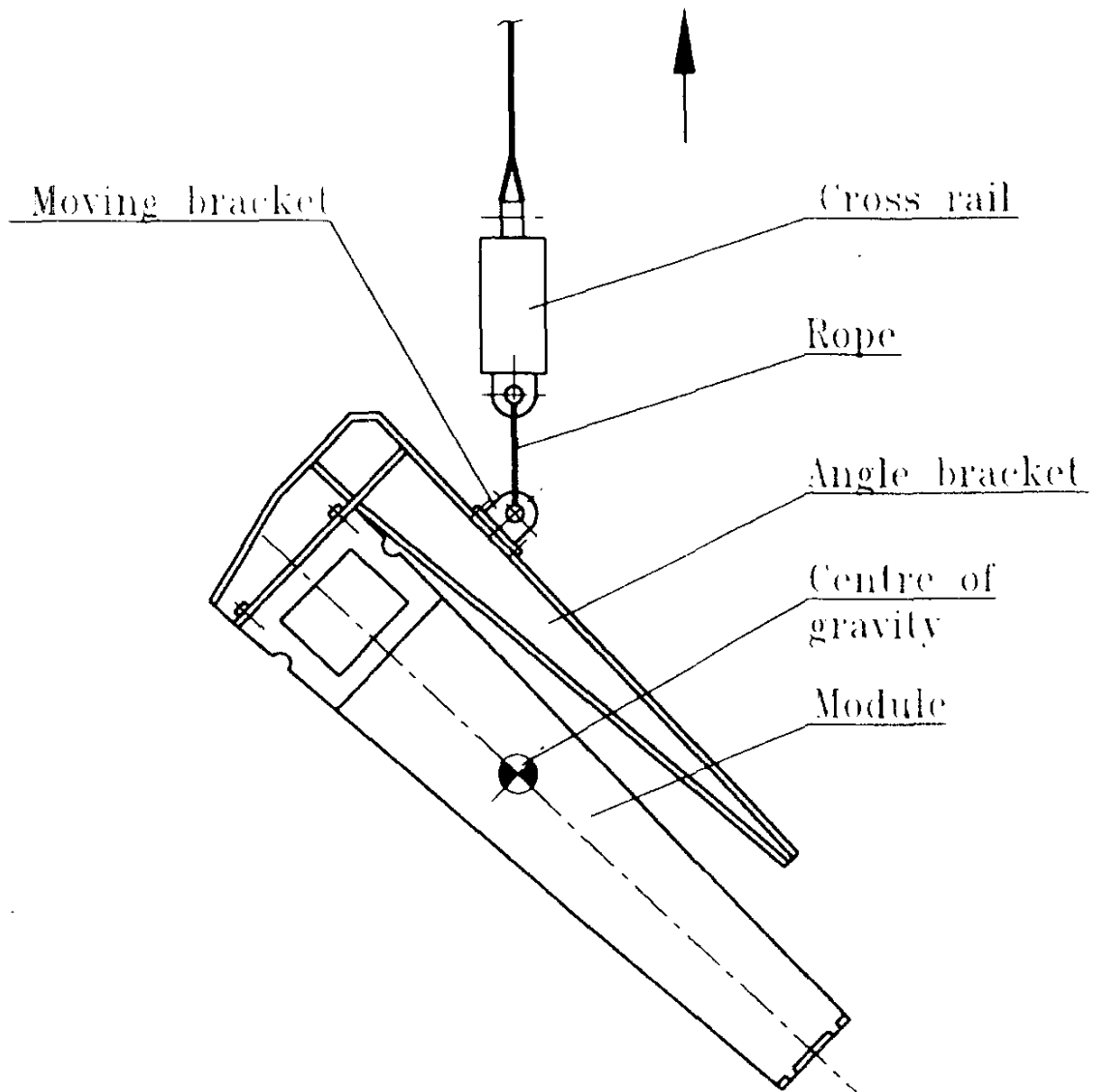

Figure 21

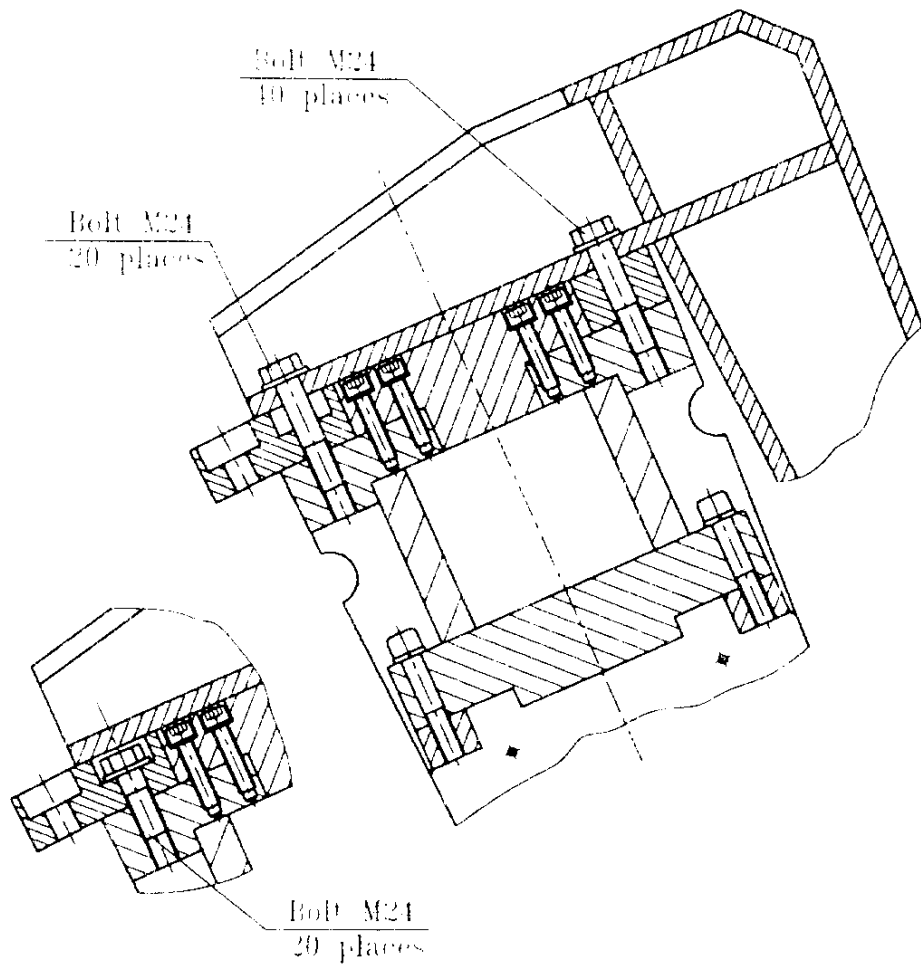

Figure 22

Received by Publishing Department
on January 24, 1995.

The Publishing Department
of the Joint Institute for Nuclear Research
offers you to acquire the following books:

Index	Title
E7-93-274	Proceedings of the International School-Seminar on Heavy Ion Physics. Dubna, 1993 (2 volumes, 498 and 590 pp., stiffened cover, in English)
Д14-93-325	Proceedings of the Workshop «Activation Analysis in Environment Protection». Dubna, 1992 (in Russian and English)
Д1,9,13-93-459	Proceedings of the II Workshop on JINR Tau-Charm Factory. Dubna, 1993 (266 p. in Russian and English)
E7-94-19	Proceedings of the International Conference on Dynamical Aspects of Nuclear Fission. Smolenice, 1993 (318 p. in English)
94-55	Proceedings of the International Bogoliubov Memorial Meeting. Dubna, 1993 (216 p. in Russian and English)
E2-94-95	Proceedings of the International Symposium «Dubna Deuteron-93». Dubna, 1993 (390 p. in English)
Д14-94-269	Abstracts of the XXX Conference on Low Temperature Physics. Dubna, 1994 (2 volumes in Russian and English)
E7-94-270	Proceedings of the Workshop on Physical Experiments and First Results on Heavy Ion Storage and Cooler Rings. Smolenice, 1992 (324 p. in English)
E13-94-290	Abstracts of the 17th International Conference «Nuclear Tracks in Solids». Dubna, 1994 (296 p. in English)
E2-94-347	International Workshop «Symmetry Methods in Physics». In Memory of Professor Yu.A.Smorodinsky. Dubna, 1993 (2 volumes, 602 p. in English)
E4-94-370	Proceedings of the IV International Conference on Selected Topics in Nuclear Structure. Dubna, 1994 (412 p. in English)

Index	Title
E4-94-386	Proceedings of the VI Trilateral German-Russian-Ukrainian Seminar on High-Temperature Superconductivity. Dubna, 1994 (340 p. in English)

Please apply to the Publishing Department of the Joint Institute for Nuclear Research for extra information. Our address is:

Publishing Department
Joint Institute for Nuclear Research
Dubna, Moscow Region
141980 Russia
E-mail: adm@pubd.jinr.dubna.su.

Будагов Ю.А. и др.

E13-95-20

Конструкция модуля барреля адронного калориметра
установки ATLAS

Представлено детальное описание модификационной версии конструкции 6-метрового модуля. Базовой идеей является использование для сборки модуля 19 склеенных субмодулей толщиной 30 см. Представлены конструкция субмодуля, технология сборки 6-метрового модуля, конструкция вспомогательного сборочного приспособления. Также описаны различные варианты строповки модулей при сборке барреля, упаковка и транспортировка модулей.

Работа выполнена в Лаборатории ядерных проблем ОИЯИ.

Сообщение Объединенного института ядерных исследований. Дубна, 1995

Budagov J. et al.

E13-95-20

ATLAS Barrel Hadron Calorimeter Module Design

Here we presented the detailed description of the 6-meter module modification design version. The basic idea is to use — for the module assembly — of 19 glued 30-cm thick submodules. The submodule design, 6 m module assembling technology, the auxiliary assembling device design are presented; also described: different options of the module's slinging when barrel assembling; modules packing and transporting.

The investigation has been performed at the Laboratory of Nuclear Problems, JINR.

Communication of the Joint Institute for Nuclear Research. Dubna, 1995

Макет Т.Е.Попеко

Подписано в печать 9.02.95
Формат 60×90/16. Офсетная печать. Уч.-изд.листов 1,67
Тираж 370. Заказ 47942. Цена 1002 р.

Издательский отдел Объединенного института ядерных исследований
Дубна Московской области