



CLIC – Note – 1168

## THE COMPACT LINEAR COLLIDER (CLIC) SNOWMASS 2021 LoI

A. Robson<sup>2</sup>, P.N. Burrows<sup>3</sup>, D. Schulte<sup>1</sup> and S. Stapnes<sup>1</sup>

<sup>1</sup>CERN, Geneva, Switzerland

<sup>2</sup>University of Glasgow, Scotland, United Kingdom

<sup>3</sup>University of Oxford, Oxford, United Kingdom

### Abstract

The Compact Linear Collider (CLIC) is a multi-TeV high-luminosity linear  $e^+e^-$  collider under development by the CLIC accelerator collaboration. The CLIC accelerator has been optimised for three energy stages at centre-of-mass energies 380 GeV, 1.5 TeV and 3 TeV.

Detailed studies of the physics potential and detector for CLIC, and R&D on detector technologies, are carried out by the CLIC detector and physics (CLICdp) collaboration. CLIC provides excellent sensitivity to Beyond Standard Model physics, through direct searches and via a broad set of precision measurements of Standard Model processes, particularly in the Higgs and top-quark sectors.

This note provides an updated status of the CLIC accelerator studies, including the plans for the time period 2021-25.

Geneva, Switzerland  
8 September 2020



# The Compact Linear Collider (CLIC) Snowmass 2021 LoI

A.Robson (University of Glasgow), P.N.Burrows (University of Oxford),  
D.Schulte and S.Stapnes (CERN)\*

## Introduction

The Compact Linear Collider (CLIC) is a multi-TeV high-luminosity linear  $e^+e^-$  collider under development by the CLIC accelerator collaboration [1]. The CLIC accelerator has been optimised for three energy stages at centre-of-mass energies 380 GeV, 1.5 TeV and 3 TeV [2].

Detailed studies of the physics potential and detector for CLIC, and R&D on detector technologies, are carried out by the CLIC detector and physics (CLICdp) collaboration [1]. CLIC provides excellent sensitivity to Beyond Standard Model physics, through direct searches and via a broad set of precision measurements of Standard Model processes, particularly in the Higgs and top-quark sectors.

The CLIC accelerator, detector studies and physics potential are documented in detail at: <http://clic.cern/european-strategy>.

## CLIC layout

A schematic overview of the accelerator configuration for the first energy stage is shown in Figure 1. To reach multi-TeV collision energies in an acceptable site length and at affordable cost, the main linacs use normal conducting X-band accelerating structures; these achieve a high accelerating gradient of 100 MV/m. For the first energy stage, a lower gradient of 72 MV/m is the optimum to achieve the luminosity goal, which requires a larger beam current than at higher energies.

intensity pulses that are distributed alongside the main linac, where they release the stored energy in power extraction and transfer structures (PETS) in the form of short RF power pulses, transferred via waveguides into the accelerating structures. This concept strongly reduces the cost and power consumption compared with powering the structures directly by klystrons.

The upgrade to higher energies is done by lengthening the main linacs. While the upgrade to 1.5 TeV can be done by increasing the energy and pulse length of the primary drive-beam, a second drive-beam complex must be added for the upgrade to 3 TeV.

An alternative design for the 380 GeV stage has been studied, in which the main linac accelerating structures are directly powered by klystrons. The further stages will also in this case be drive-beam based.

## Parameter overview

The parameters for the three energy stages of CLIC are given in Table I. The baseline plan for operating CLIC results in an integrated luminosity per year equivalent to operating at full luminosity for  $1.2 \times 10^7$  s [3]. Foreseeing 8, 7 and 8 years of running at 380, 1500 and 3000 GeV respectively, and a luminosity ramp up for the first years at each stage, integrated luminosities of 1.0, 2.5 and 5.0  $\text{ab}^{-1}$  are reached for the three stages.

CLIC provides  $\pm 80\%$  longitudinal electron polarisation and proposes a sharing between the two polarisation states at each energy stage for optimal physics reach [4].

## Luminosity margins and performance

In order to achieve high luminosity, CLIC requires very small beam sizes at the collision point, as listed in Table I. Recent studies have explored the margins and possibilities for increasing the luminosity, operation at the Z-pole and gamma-gamma collisions [5].

The vertical emittance and consequently the luminosity are to a large extent determined by imperfections in the accelerator complex. Significant margin has been added to the known effects to enhance the robustness of the design; without imperfections a factor three higher luminosity would be reached at 380 GeV [6]. At this energy also the repetition rate of the facility, and consequently luminosity, could be doubled from 50 Hz to 100 Hz without major changes and with relatively little increase in the overall power consumption and cost (at the  $\sim 30\%$  and  $\sim 5\%$  levels, respectively). This is because a large fraction of the power is used by systems where the consumption is independent of the repetition rate.

The CLIC beam energy can be adjusted to meet different physics requirements. In particular, a period of operation around 350 GeV is foreseen to scan the top-quark pair-production threshold. Operation at much lower ener-

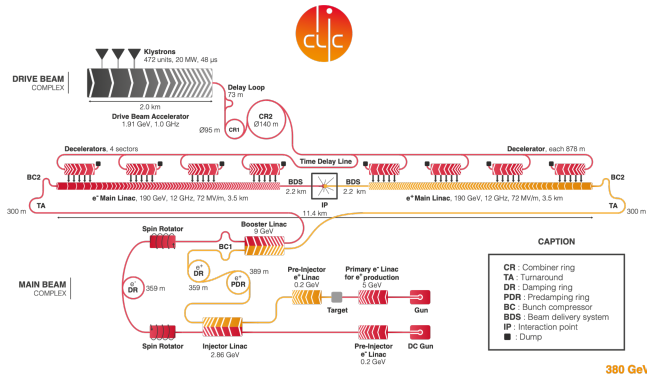

Figure 1. Schematic layout of the CLIC complex at 380 GeV.

In order to provide the necessary high peak power, the novel drive-beam scheme uses low-frequency klystrons to efficiently generate long RF pulses and to store their energy in a long, high-current drive-beam pulse. This beam pulse is used to generate many short, even higher

\* Summarized on behalf of the CLIC accelerator study  
Contact person: [steinar.stapnes@cern.ch](mailto:steinar.stapnes@cern.ch)

Table I. Key parameters of the CLIC energy stages.

Parameter	Unit	Stage 1	Stage 2	Stage 3
Centre-of-mass energy	GeV	380	1500	3000
Repetition frequency	Hz	50	50	50
Nb. of bunches per train		352	312	312
Bunch separation	ns	0.5	0.5	0.5
Pulse length	ns	244	244	244
Accelerating gradient	MV/m	72	72/100	72/100
Total luminosity	$10^{34}$	1.5	3.7	5.9
Lum. above 99% of $\sqrt{s}$	$10^{34}$	0.9	1.4	2
Total int. lum. per year	$\text{fb}^{-1}$	180	444	708
Main linac tunnel length	km	11.4	29.0	50.1
Nb. of particles per bunch	$10^9$	5.2	3.7	3.7
Bunch length	$\mu\text{m}$	70	44	44
IP beam size	nm	149/2.9	$\sim 60/1.5$	$\sim 40/1$
Norm. emitt. (end linac)	nm	900/20	660/20	660/20
Final RMS energy spread	%	0.35	0.35	0.35
Crossing angle (at IP)	mrad	16.5	20	20

gies can also be considered. Running at the Z-pole results in an expected luminosity of about  $2.3 \times 10^{32} \text{ cm}^{-2} \text{ s}^{-1}$  for an unmodified collider. On the other hand, an initial installation of just the linac needed for Z-pole energy factory, and an appropriately adapted beam delivery system, would result in a luminosity of  $0.36 \times 10^{34} \text{ cm}^{-2} \text{ s}^{-1}$  for 50 Hz operation. Furthermore, gamma-gamma collisions at up to  $\sim 315$  GeV are possible with a luminosity spectrum interesting for physics.

### Technical maturity

Accelerating gradients of up to 145 MV/m have been reached with the two-beam concept at the CLIC Test Facility (CTF3). Breakdown rates of the accelerating structures well below the limit of  $3 \times 10^7 \text{ m}^{-1}$  per beam pulse are being stably achieved at X-band test platforms.

Substantial progress has been made towards realising the nanometre-sized beams required by CLIC for high luminosities: the low emittances needed for the CLIC damping rings are achieved by modern synchrotron light sources; special alignment procedures for the main linac are now available; and sub-nanometre stabilisation of the final focus quadrupoles has been demonstrated. The advanced beam-based alignment of the CLIC main linac has successfully been tested in FACET and FERMI [7, 8].

Other technology developments include the main linac modules and their auxiliary sub-systems such as vacuum, stable supports, and instrumentation. Beam instrumentation, including sub-micron level resolution beam-position monitors with time accuracy better than 20 ns and bunch-length monitors with resolution better than 20 fs, have been developed and tested with beam in CTF3.

Recent developments, among others, of high efficiency klystrons have resulted in an improved energy efficiency for the 380 GeV stage, as well as a lower estimated cost.

### Schedule, cost estimate, and power consumption

The technology and construction-driven timeline for the CLIC programme is shown in Figure 2 [9]. This schedule

has seven years of initial construction and commissioning. The 27 years of CLIC data-taking include two intervals of two years between the stages.

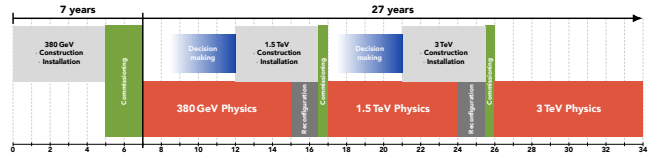

Figure 2. Technology and construction-driven CLIC schedule. The time needed for reconfiguration (connection, hardware commissioning) between the stages is also indicated.

The cost estimate of the initial stage is approximately 5.9 billion CHF. The energy upgrade to 1.5 TeV has an estimated cost of approximately 5.1 billion CHF, including the upgrade of the drive-beam RF power. The cost of the further energy upgrade to 3 TeV has been estimated at approximately 7.3 billion CHF, including the construction of a second drive-beam complex.

The nominal power consumption at the 380 GeV stage is approximately 170 MW. Earlier estimates for the 1.5 TeV and 3 TeV stages yield approximately 370 MW and 590 MW, respectively [10], however recent power savings applied to the 380 GeV design have not yet been implemented for these higher energy stages. The annual energy consumption for nominal running at the initial energy stage is estimated to be 0.8 TWh. For comparison, CERN's current energy consumption is approximately 1.2 TWh per year, of which the accelerator complex uses approximately 90%.

### Programme 2021-25

The design and implementation studies for the CLIC  $e^+e^-$  multi-TeV linear collider are at an advanced stage. The main technical issues, cost and project timelines have been developed, demonstrated and documented.

During the coming years the focus will remain on core technology development and dissemination, which will capitalise on existing facilities (X-band test stands and the CLEAR beam facility at CERN), as well as optimising X-band components and RF-systems, involving extensive collaborations with laboratories and universities using the technology.

The use of the CLIC technology - primarily X-band RF, associated components and nano-beams - in compact medical, industrial and research linacs has become an increasingly important development and test ground for CLIC, and is destined to grow further [11]. The adoption of CLIC technology for these applications is now providing a significant boost to CLIC, especially through an enlarging commercial supplier base.

On the design side the parameters for running at multi-TeV energies, with X-band or other RF technologies, will be studied further, in particular with energy efficiency guiding the designs.

- 
- [1] “Compact Linear Collider (CLIC),” Last accessed August 31, 2020.
- [2] P. N. Burrows, P. Lebrun, L. Linssen, D. Schulte, E. Sickling, S. Stapnes, and M. A. Thomson, eds., *Updated baseline for a staged Compact Linear Collider*, CERN-2016-004 (2016).
- [3] F. Bordry *et al.*, “Machine Parameters and Projected Luminosity Performance of Proposed Future Colliders at CERN,” (2018), [arXiv:1810.13022](https://arxiv.org/abs/1810.13022) [physics.acc-ph].
- [4] P. Roloff and A. Robson, “Updated CLIC luminosity staging baseline and Higgs coupling prospects,” (2018).
- [5] C. Gohil, A. Latina, D. Schulte, and S. Stapnes, “High-Luminosity CLIC Studies,” (2020).
- [6] C. Gohil *et al.*, “Luminosity Performance of the Compact Linear Collider at 380 GeV with Static and Dynamic Imperfections (submitted to Phys. Rev. Accel. Beams),” (2020).
- [7] “FACET Facility for Advanced Accelerator Experimental Tests,” Last accessed August 31, 2020.
- [8] “FERMI Free Electron laser Radiation for Multidisciplinary Investigations,” Last accessed August 31, 2020.
- [9] P. N. Burrows *et al.*, eds., *CLIC Project Implementation Plan*, CERN Yellow Reports: 4/2018 (2018).
- [10] M. Aicheler, P. Burrows, M. Draper, T. Garvey, P. Lebrun, K. Peach, N. Phinney, H. Schmickler, D. Schulte, and N. Toge, eds., *A Multi-TeV Linear Collider Based on CLIC Technology: CLIC Conceptual Design Report*, CERN-2012-007 (2012).
- [11] G. D’Auria *et al.*, “Status of the CompactLight Design Study,” (2019).