

DD

849431

DUMAND: Facts, Figures and Initial Operation*

Peter K. F. Grieder
Physikalisches Institut, University of Bern
Switzerland

For the DUMAND Collaboration †

CERN LIBRARIES, GENEVA



P00024633

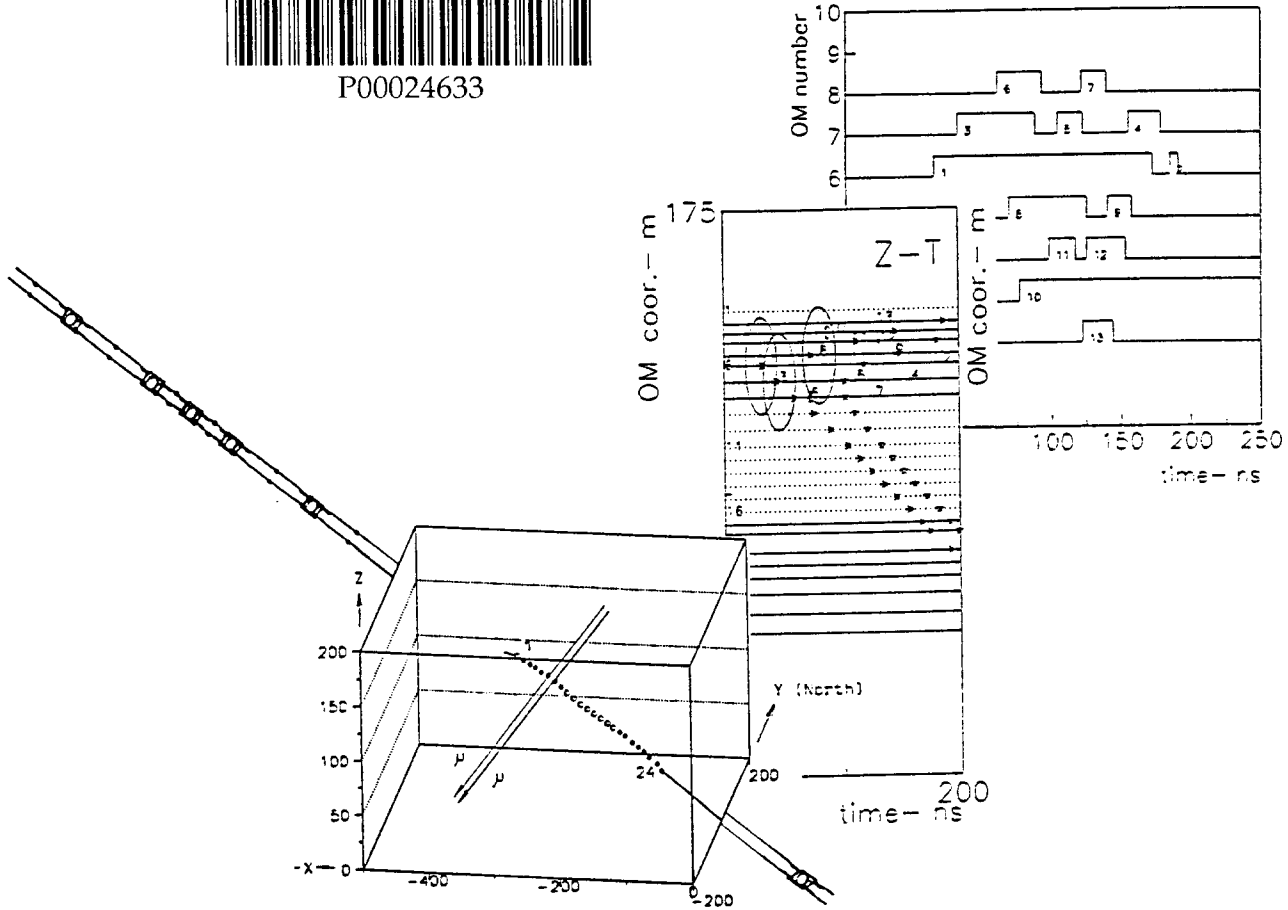

*Paper submitted to the XVI International Conference on Neutrino Physics and Astrophysics
Eilat, Red Sea, Israel, May 29 - June 3, 1994.

†See next page for complete list.

DUMAND: Facts, Figures and Initial Operation *

Peter K. F. Grieder [1]

For the DUMAND Collaboration

T. Aoki [10], H. G. Berns [14], U. Berson [13], P. Bosetti [13], J. Bolesta [3], P.E. Boynton [14], H. Bradner [8], U. Braun [13], U. Camerini [15], R. Clark [17], H. Crawford [19], S.T. Dye [2], J. George [14], E. Gergin [2], P.W. Gorham [3], P.K.F. Grieder [1], W. Grogan [15], H. Hanada [9], D. Harris [3], J. Hauptman [16], T. Hayashino [9], E. Hazen [2], A. Iwasaki [9], M. Jaworksi [15], M. Jenko [2], A. Kibayashi [3], T. Kitamura [6], K. Kobayakawa [5], S. Kondo [3], P. Koske [4], C. Kuo [19], J.G. Learned [3], C. Ley [13], J.J. Lord [14], R. Lord [14], T. Lozic [2], R. March [15], T. Matsumoto [9], S. Matsuno [3], A. Mavretic [2], L. McCourry [14], M. Mignard [3], K. Miller [12], P. Minkowski [1], R. Mitiguy [3], K. Mitsui [10], S. Narita [9], T. Narita [15], D. Nicklaus [15], K. O'Brien [16], D. O'Connor [3][†], Y. Ohashi [10], A. Okada [10], D. Orlov [2], V.Z. Peterson [3], A. Roberts [3], M. Rosen [3], G. Shapiro [19], V.J. Stenger [3], R. Svoboda [17], T. Takayama [9], D. Takemori [3], S. Tanaka [18], E. Torrente - Lujan [1], S. Uehara [11], C.H. Wiebusch [13], G. Wilkins [3], M. Webster [12], R.J. Wilkes [14], G. Wurm [13], A. Yamaguchi [9], I. Yamamoto [7], and K.K. Young [14]

[1] University of Bern, Switzerland; [2] Boston University, USA; [3] University of Hawaii, USA; [4] University of Kiel, Germany; [5] Kobe University, Japan; [6] Kinki University, Japan; [7] Okayama Science University, Japan; [8] Scripps Institution of Oceanography, USA; [9] Tohoku University, Japan; [10] ICRR, University of Tokyo, Japan; [11] KEK, Tsukuba, Japan; [12] Vanderbilt University, USA; [13] Vrije Universiteit, Netherlands; [14] University of Washington, USA; [15] University of Wisconsin, USA; [16] Iowa St. University, USA; [17] Louisiana State University, USA; [18] Hiroshima University, Japan; [19] University of California, Berkeley, USA.

*Paper submitted to the XVI International Conference on Neutrino Physics and Astrophysics Eilat, Red Sea, Israel, May 29 - June 3, 1994

[†]Now at Pisa.

Abstract

After the successful completion of the short prototype string experiment late in 1987, the DUMAND (Deep Underwater Muon and Neutrino Detector) Collaboration began with the development and construction of DUMAND Stage II. This detector system consists of nine so-called strings of 24 highly sophisticated optical Cherenkov detector modules each. The strings will be arranged in the form of a giant octagon, totalling 216 modules that will be installed at a depth of nearly 5000 m in the Pacific ocean and operated as a muon and neutrino telescope. The effective area is roughly 20,000 m² and the expected angular resolution about 1°. The contained volume of the array is $1.8 \cdot 10^6$ m³ and the neutrino point source sensitivity $4 \div 7 \cdot 10^{-10}$ cm⁻²s⁻¹ per year above 1 TeV.

In December 1993 the 35 km long 12-fiber electro-optical shore cable was deployed together with the junction box, the sonar and video systems, and the first of three completed strings. We discuss deployment, string installation and initial operation. Due to problems, string 1 was recovered late in January for inspection and repair. The cause for the difficulties is outlined and plans for re-deployment of string 1 together with strings 2 and 3 are presented. Initial results from data obtained in December 1993 confirm expected sensitivity and noise rates.

1 Introduction

After the successful completion of the short prototype string experiment late in 1987 [1], the DUMAND³ Collaboration began with the development and construction of DUMAND Stage II. This detector system is a giant three-dimensional array of 216 highly sophisticated optical Cherenkov detector modules [2], intended to be used as a muon and neutrino telescope.

The array consists of nine so-called strings of 24 detector modules each. Eight strings are located at the corners of an equilateral octagon, 40 m apart, with the ninth string at the center. The basic sensors consist of 15-inch diameter photomultiplier tubes. The array configuration is shown in figure 1. It will be located about 30 km west of Keahole Point, the most western tip of the Island of Hawaii, at a depth of 4760 m. The array's effective area is about 20,000 m², its point source sensitivity $4 \div 7 \cdot 10^{-10} \nu \text{ cm}^{-2} \text{ s}^{-1}$ per year for muon neutrinos of energy ≥ 1 TeV, and its angular resolution is $\approx 1^\circ$. More detailed descriptions of the array and its capabilities are given elsewhere [3,4,5,6].

Phase I of this project, called the TRIAD detector [7], is now in the process of being completed. This phase includes deployment, installation and taking into operation of three out of the nine strings, and of a large multi-connector junction box (figure 2), located in the center of the DUMAND site, for connecting the individual strings. It also includes laying of a 12-fiber electro-optical cable from the junction box to shore. This cable supplies power to the junction box and establishes multiple high-speed two-way color multiplexed single mode command and data links between the deep ocean laboratory and the shore station.

Various support systems such as a very high precision sonar, television cameras with floodlights, etc., are either integrated with or suspended above the junction box. These facilitate installation, recovery and re-installation after servicing of strings, and help to guide a robot or manned submersible when connecting equipment to the junction box. The precision sonar in conjunction with the 52 hydrophones incorporated in the array also allows to locate the position of each module of the array to within a few centimeters, to maintain the high angular resolution and pointing accuracy.

In addition the array also has significant capability to detect cascades of particles, as well as muons. If active galactic nuclei (AGNs) generate $\bar{\nu}_e$ at predicted levels [8], then DUMAND II might be able to see such events from throughout a volume as large as 0.2 km³. The hydrophones in the array may also permit hearing such extraordinary events.

Other physics capabilities have been extensively discussed elsewhere [8,6]. These include studies of neutrino oscillations, searches for various exotica (WIMPS, mo-

³Deep Underwater Muon and Neutrino Detector

nopoles, quark nuggets), and even mapping the earth core density [9].

2 Deployment of Phase I Equipment

In December 1993 the DUMAND collaboration has deployed during a major oceanographic operation the basic infrastructure of its deep ocean laboratory at the DUMAND site. It consists of the junction box with 12 combined electro - optical connectors, the 12-fiber electro - optical shore cable that links the connectors to the shore station, and string 1, the center string of the octagonally shaped detector matrix.

Since we had at that time no deep ocean submarine or remotely operated work vehicle available, there was no point to deploy the remaining two strings to complete Phase I, the TRIAD configuration of DUMAND II, as planned initially, because strings two and three could not have been connected to the junction box and brought into operation.

String 1 was mechanically attached to the junction box and electrically and optically connected to the shore station through one of the junction box connectors. The highly complex deployment procedure, which had to be conducted in one uninterrupted operation, is illustrated in figure 3.

The string was deployed first and in an upside down configuration, beginning with a sacrificial anchor, followed by the different modules and subsystems, the junction box, and subsequently the cable laying procedure (c.f. fig. 3). The entire operation took 32.5 hours until the 12-fiber electro - optical cable was on shore. The junction box touched ground early in the morning of December 15.

During the lowering operation, string 1 was powered as soon as the ambient light in the ocean reached a safe level for the phototubes (≈ 1 km depth). It was checked continuously for proper operation through the full 35 km length of the shore cable on board the ship, using the appropriate fiber for the color multiplexed two-way data and command communication.

The two video cameras positioned near the bottom of the string, above the junction box, were activated at the beginning of the deployment to get some views from the shallow zone where adequate ambient lighting from the sun still persisted. After shore termination of the cable further pictures of the junction box before and after sacrificial anchor release were recorded.

3 Initial String Operation and Data Recording

Approximately one hour after touchdown of the junction box, during the cable laying procedure, normal mode string operation was started, while the string was kept in inclined position, as shown in figure 3.5, to avoid entanglement with the shore cable. Vertical positioning of the string by remotely controlled release of the sacrificial anchor was intended to be activated from the shore station, after completion of cable laying.

The data were recorded using a very simplified data acquisition system on board the ship that consisted essentially of a large high-speed buffer (5 Mbyte) which recorded the string data that were transmitted at a rate of 625 Mbd. No extensive data analysis or event reconstruction was possible during this time.

Whenever the buffer was full the memory was dumped onto a disk. The copying procedure was very time consuming and dictated a duty factor for the real time data acquisition of only about one percent whereas the shore station is capable to handle up to 1 Gbd per string. A total of 3 Gigabyte of data, corresponding to about two minutes of real time, were recorded over a period of about three hours during which cable deployment progressed as scheduled.

About five hours after touchdown of the junction box, while deployment was in progress, problems with the data and command link developed and eventually control of string 1 was lost. After completion of the cable laying operation and passing the shore cable through the cable conduit that guides the cable safely through the surf area and shore rocks into the shore station building, the junction box was powered again. Unfortunately the string controller did not respond. However, the television and sonar systems that have their independent and self contained control, data handling and transmission system that is connected to a separate junction box outlet responded properly and could be tested extensively.

After powering the floodlights that are mechanically coupled to the video cameras a clear picture of the junction box appeared on the monitor, revealing that the junction box is in fact properly positioned on the ocean floor. Pivoting the camera showed the part of the lower portion of the string still in its inclined position.

Since string control was lost the sacrificial anchor could not be remotely released and the string could not rise into vertical position. It was therefore necessary to wait for the corrosion activated magnesium fuse to release the string from the anchor. This occurred on December 20. Inspection with the video camera revealed that the string was now in vertical position.

Subsequent electrical tests carried out from the shore station indicated that now the power line was shorted to the ocean, putting the entire system out of service. It was assumed that a full short circuit had occurred in the string controller as the string moved into vertical position, suggesting sea water in the lower portion of the

controller housing, where the power handling system is located.

To disconnect the string controller electrically from the junction box, a well defined current was applied to the shore cable to blow the 10 A fuse located in the plug at the end of the umbilical cable that connects to the junction box. Care was taken to save the 15 A fuse in the socket at the junction box, not to disable the outlet. This operation was successful and the sonar and television systems were operational again.

4 Preliminary Results

The data recorded during the short time of partial operation of the string at the nominal depth of 4760 m are in the process of being analyzed. Most of the data are of course just potassium 40 background light induced counts. However, a very simple trigger had been applied to the raw data and simple fits were used to look for muon trajectories. This work is still in progress. We only present the result of a preliminary analysis of a rather remarkable event as an example.

In figure 4 we show the string configuration at the time of data taking. Figure 5 shows the timing chart (time over threshold) of the previously mentioned particular event. Though it has not been fully analyzed, it appears to be a two - muon event, possibly with a muon burst because of the large amplitudes (≥ 100 times minimum ionizing) in modules number 5, 6 and 7. Bioluminescence is totally excluded because of the time structure and the confinement of the large brightness.

The connected asterisks in the chart indicate how a single muon trajectory would look that intercepts the string at right angle between modules number 4 and 5. This signature is typical for perpendicular tracks passing close to the string.

The event shown in figure 5 had been reconstructed and is illustrated in the form of a timing plot in figure 6. The ordinate represents the Z-axis and shows the actual vertical position of every module, indicated by a horizontal line and numbered from 1 (top module) to 24, along the axis. Solid horizontal lines identify the active modules, dotted lines deactivated modules. The numbers within the figure represent the hits, the ellipsis centered about some of the numbers the amplitude of the signal, if it is large enough. The asterisks and stars represent the timing of the two reconstructed muon tracks. The directional errors are large because of the small number of detector modules that were active at the time of measurement.

Figure 7 shows a spatial plot of the string and the two reconstructed muon trajectories.

Further information from the data tells us that the photomultiplier noise rate is lower than anticipated (mean ≤ 60 kHz, and still quieting), that the bioluminescent pulses (as expected) provide a dead time of $\approx 1\%$ per module, and that correlations

of high light levels between modules are very small. The implication of the latter is that the bioluminescence light pulses (≈ 1 second duration) are small and localized. Perhaps most important, the sensitivity of the array is close to predictions, based upon the observed coincidence rate.

5 String Recovery and Problem Determination

On January 27, 1994 a team sailed to the DUMAND site on a small boat and released string 1 by sonar control. 63 minutes later the string surfaced and was recovered and brought to Honolulu. Since there was no possibility to unplug the umbilical cable from the junction box in this operation, it had to be severed above the latter, leaving the end exposed to the ocean. The connector with the remaining loose section of cable and fiber will be removed by the robot when installing the next string.

Upon opening of the string controller housing 4.5 liters of sea water were found inside. This explained the short and its consequences. Considering that the string controller was 45 days in the ocean at full depth yields a leak rate of about 1 mm^3 per second, or roughly one drop per minute. Previous pressure testing of the unit at 10,000 lbs/sq.in. showed no leak.

Very careful inspection of the controller housing with its almost 60 optical and electrical high pressure penetrators finally led to the discovery of a tiny but nevertheless disastrous leak. It could be located at one of the electrical penetrators, a 3-pin Crouse - Hinds rubber - titanium penetrator. Detailed investigation revealed that the leak developed between the titanium mount and the rubber insulation. It appeared that the two materials did not bond properly. It is likely that the leak occurred when connecting and/or disconnecting receptacle and penetrator. Plans to prevent repetition of this failure have been formulated - basically more extensive pressure testing.

6 Concluding Remarks

The destroyed string controller is now in the process of being rebuilt. It will be re-installed together with the two other strings in the near future. The DUMAND Collaboration has learned a large number of important lessons from the December 1993 deployment, and look forward to a successful installation of the three strings in the Fall of 1994.

7 Acknowledgements

The DUMAND Collaboration is grateful to the following organizations and funding agencies for supporting the project: Bundesministerium für Forschung und Technologie (BMFT), Germany; Federal State of Schleswig - Holstein, Germany; Japanese Science Foundation Mombusho; Japan Society for the Promotion of Science; Swiss National Science Foundation; U.S. Department of Energy; U.S. National Science Foundation; Wolfermann - Nägeli Stiftung, Kilchberg, Switzerland.

Thanks go to the many, too numerous to mention, who helped bring DUMAND to this state of construction. In particular we want to acknowledge generous help from the crew of the R/V Thomas G. Thompson during the December 1993 deployment.

References

- [1] J. Babson, B. Barish, R. Becker-Szendy, H. Bradner, R. Cady, J. Clem, S. Dye, J. Gaidos, P. Gorham, P.K.F. Grieder, T. Kitamura, W. Kropp, J.G. Learned, S. Matsuno, R. March, K. Mitsui, D. O'Connor, Y. Ohashi, A. Okada, V. Peterson, L. Price, F. Reines, A. Roberts, C. Roos, H. Sobel, V.J. Stenger, M. Webster, C. Wilson: Cosmic Ray Muons in the Deep Ocean. *Phys. Rev. D* 42, p. 3613-3620 (1990).
- [2] S. Matsuno, J. Babson, J.G. Learned, D. O'Connor, P.K. Grieder, K. Mitsui, Y. Ohashi, A. Okada, J. Clem, M. Webster, and C. Wilson: Single photon light detector for deep ocean applications. *Nuclear Instruments and Methods*, A276, pp. 359-366. (1989).
- [3] P. Bosetti, P.K.F. Grieder, W. Gajewski, W. Kropp, L. Price, F. Reines, H. Sobel, B. Barish, J. Elliott, J. Babson, R. Becker-Szendy, J.G. Learned, S. Matsuno, D. O'Connor, A. Roberts, V.J. Stenger, V.Z. Peterson, G. Wilkins, O.C. Allkofer, P. Koske, M. Preischel, J. Rathlev, T. Kitamura, H. Bradner, K. Mitsui, Y. Ohashi, A. Okada, J. Clem, C.E. Roos, M. Webster, U. Camerini, M. Jaworski, R. March, and R. Morse. DUMAND II. Proposal to construct a deep ocean laboratory for the study of high energy neutrino astrophysics and particle physics. University of Hawaii Publication, HDC-2-88, p. 1-155 (1988).
- [4] P.K.F. Grieder: "DUMAND Stage II Status Report". Lecture presented at the 3rd Nestor International Workshop, October 19 - 21, 1993, Pylos, Greece. L. Resvanis ed. (in print).

- [5] V.J. Stenger: Optimizing Deep Underwater Neutrino Detectors. Proceedings of the 2nd Nestor International Workshop, October 1992, Pylos, Greece, L. Resvanis ed., p. 101 (1993).
- [6] See also the DUMAND contributions to the XXIII. International Cosmic Ray Conference, Calgary, Canada, 1993).
- [7] V.J. Stenger for the DUMAND Collaboration: C.M. Alexander, T. Aoki, U. Berson, P. Bosetti, J. Bolesta, P.E. Boynton, H. Bradner, U. Camerini, S.T. Dye, M. Fukawa, E. Gergin, P.W. Gorham, G. Grajew, P.K.F. Grieder, W. Grogan, H. Hanada, D. Harris, T. Hayashino, E. Hazen, M. Ito, M. Jaworksi, M. Jenko, H. Kawamoto, T. Kitamura, K. Kobayakawa, S. Kondo, P. Koske, J.G. Learned, J.J. Lord, R. Lord, T. Lozic, R. March, T. Matsumoto, S. Matsuno, A. Mavretic, L. McCourry, M. Mignard, K. Miller, P. Minkowski, R. Mitiguy, K. Mitsui, S. Narita, D. Nicklaus, K.M. O'Brien, Y. Ohashi, A. Okada, D. Orlov, V.Z. Peterson, A. Roberts, V.J. Stenger, T. Takayama, S. Tanaka, S. Uehara, C. Wiebusch, G. Wilkins, M. Webster, R.J. Wilkes, G. Wurm, O. Watanabe, A. Yamaguchi, I. Yamamoto, K.K. Young: "Capabilities of the DUMAND II Phase I - 3 String Array". Proceedings of the XXIII. Internat. Cosmic Ray Conf., Calgary, Canada, 4, p. 527 (1993).
- [8] See Proceedings of the Workshop on High energy Neutrino Astrophysics, University of Hawaii, 1992. Ed. V.J. Stenger, J.G. Learned, S. Pakvasa and X. Tata. World Scientific, Singapore (1992).
- [9] See H. Crawford, C. Kuo, and G. Shapiro. This conference.

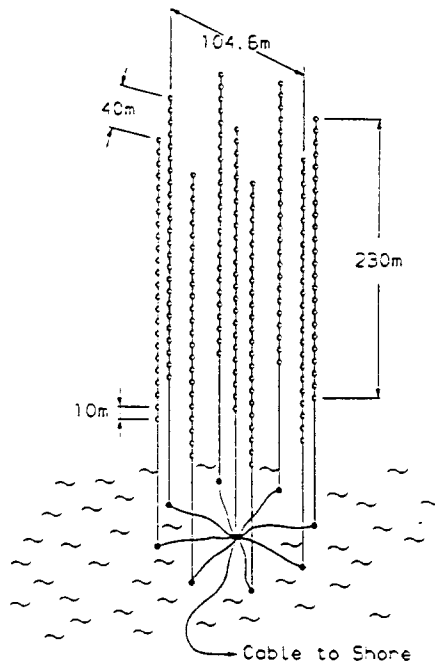

Figure 1: DUMAND Stage II Octagon array configuration. Shown are only the optical Cherenkov detector modules. The string controller and communication system is located in the center of each string. In addition the array has 52 wide-band hydrophones for module positioning in conjunction with a highly sophisticated sonar system, and for the detection of high energy cosmic ray induced acoustic shocks.

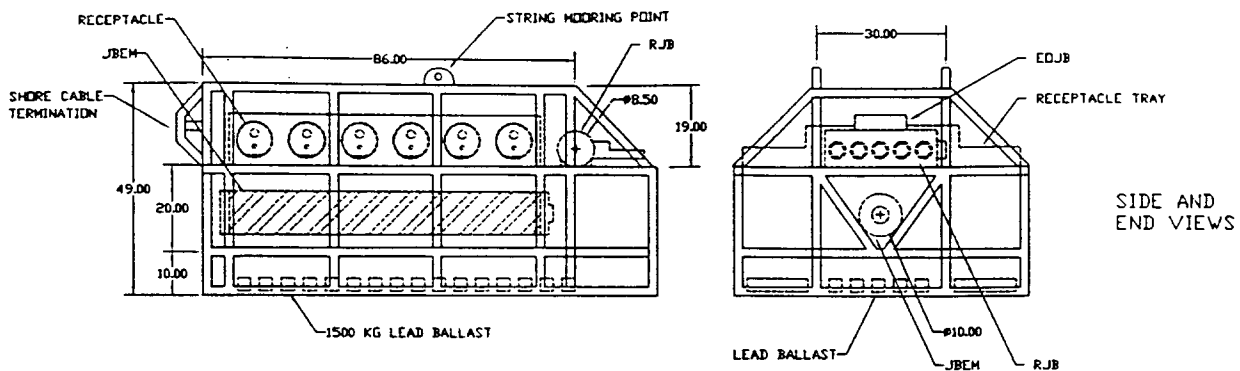

Figure 2: Side and end views of the DUMAND junction box. It has 6 combined electrical and optical single mode connectors on either side to power the strings and handle high speed bi-directional communication, and 5 dedicated connectors on its end for the sonar responders. The cylindrical unit in the lower center portion (JBEM) houses the sonar, environmental monitoring and television systems.

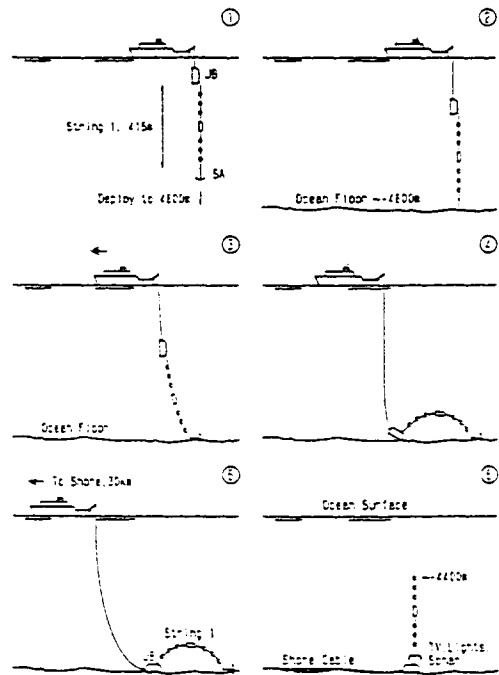

Figure 3: Illustrations of the different phases of the deployment procedure of DUMAND string 1, junction box and shore cable from the research vessel Thomas G. Thompson.

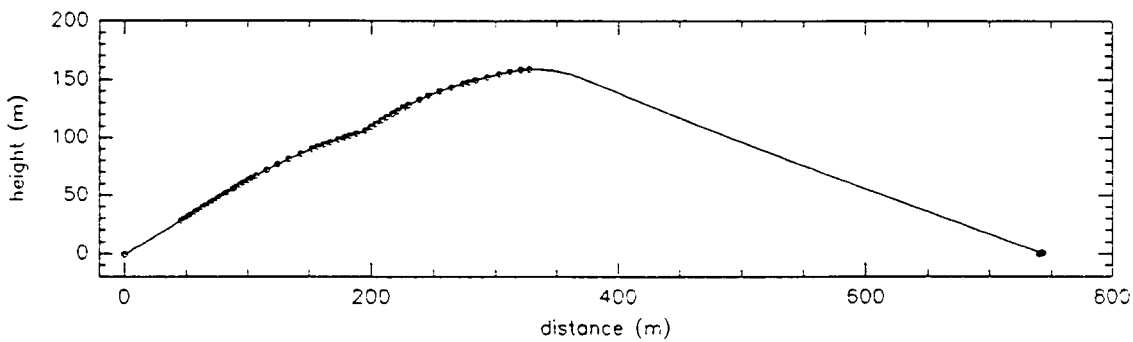

Figure 4: String configuration after deployment of junction box, during the cable laying operation. The first data were taken while the string was kept in this position. The circle at the origin represents the junction box, the mark on the right hand end of the string the sacrificial anchor. The circles to the left of the culmination indicate modules and floatation units. The dip in the curve is due to the heavy string controller.

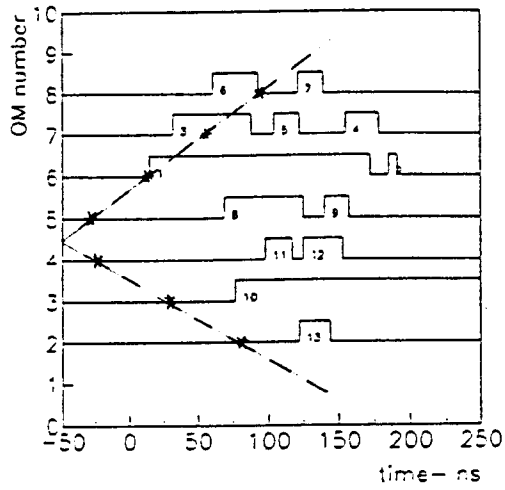

Figure 5: Timing chart of a large event. There are 13 pulses within 170 ns. Preliminary analysis shows that it is a two-muon event with a burst presumably due to muon bremsstrahlung. The asterisks indicate the timing sequence expected for a single muon track that intercepts the string perpendicularly.

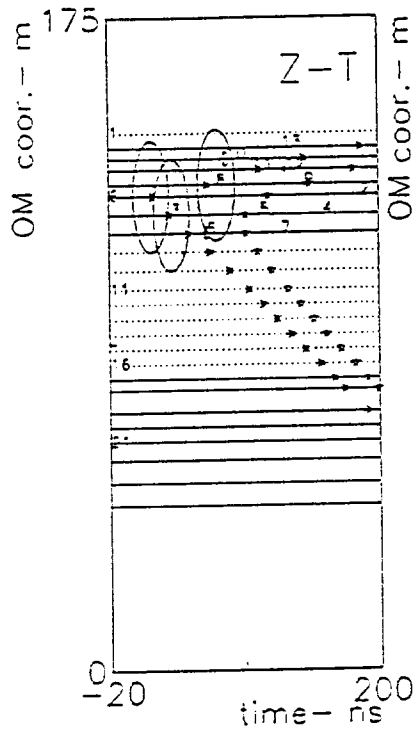

Figure 6: Timing evolution of two reconstructed muon tracks of the event shown in figure 5. The ordinate represents the Z-axis and shows the actual vertical position of every module, numbered from 1 (top module) to 24, along the axis (c.f. fig. 4). The ellipses are proportional to the signal. The numbers within the figure are PMT hit labels. Dashed lines identify deactivated modules.

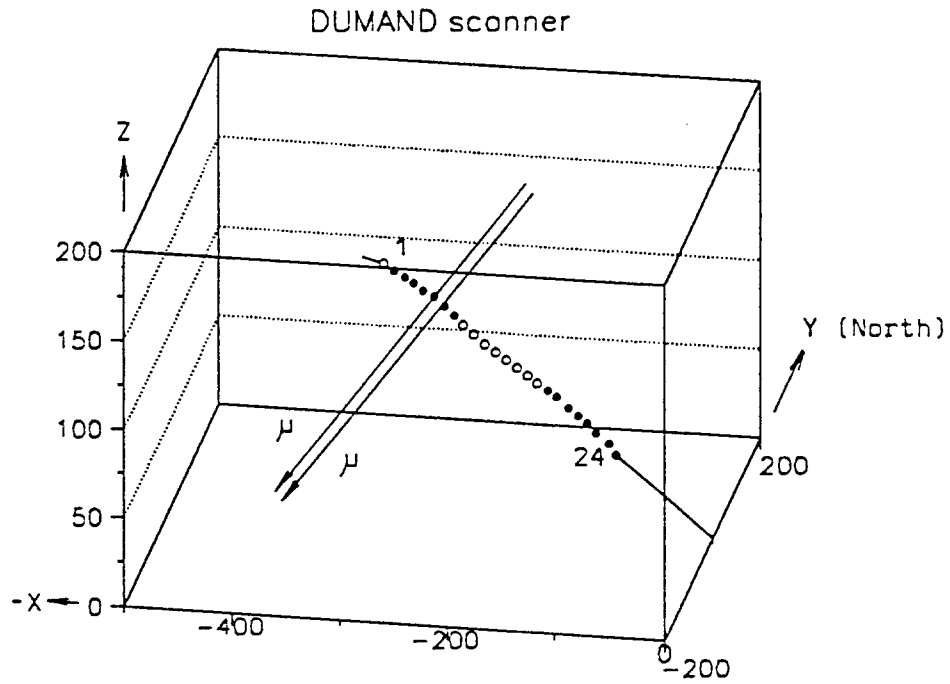

Figure 7: Spatial plot of the same event shown in figures 5 and 6. Shown are the two reconstructed muon tracks to the left of the string. The latter was inclined at the time the data was taken; it lies in the X- Z-plane, pointing west (for details see text and fig. 4) Full and open circles identify active and deactivated modules, respectively. Dimensions are in meters.