

SSCL-664

SSCL-664

823415

March 1994

Distribution Category: 400

L. Walling
Y. Goren
S. Kwiatkowski

ANT Tuner Retrofit for LEB Cavity

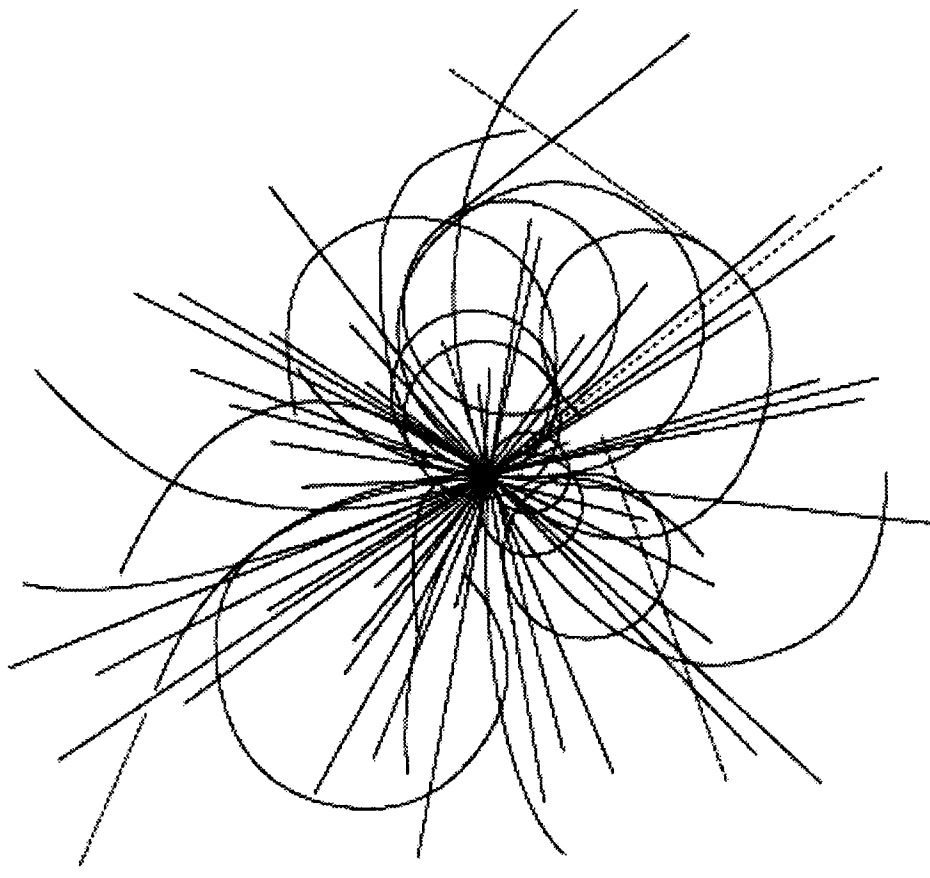

CERN LIBRARIES, GENEVA



P00022273

Superconducting Super Collider Laboratory

Disclaimer Notice

This report was prepared as an account of work sponsored by an agency of the United States Government. Neither the United States Government or any agency thereof, nor any of their employees, makes any warranty, express or implied, or assumes any legal liability or responsibility for the accuracy, completeness, or usefulness of any information, apparatus, product, or process disclosed, or represents that its use would not infringe privately owned rights. Reference herein to any specific commercial product, process, or service by trade name, trademark, manufacturer, or otherwise, does not necessarily constitute or imply its endorsement, recommendation, or favoring by the United States Government or any agency thereof. The views and opinions of authors expressed herein do not necessarily state or reflect those of the United States Government or any agency thereof.

Superconducting Super Collider Laboratory is an equal opportunity employer.

ANT Tuner Retrofit for LEB Cavity

L. Walling, Y. Goren, and S. Kwiatkowski

Superconducting Super Collider Laboratory*
2550 Beckleymeade Ave.
Dallas, TX 75237 USA

March 1994

*Operated by the Universities Research Association, Inc., for the U.S. Department of Energy under Contract No. DE-AC35-89ER40486.

1.0 INTRODUCTION

This report describes a ferrite tuner design for the LEB cavity that utilizes techniques for bonding ferrite to metallic cooling plates that is utilized in the high-power rf and microwave industry. A test tuner was designed to fit into the existing LEB-built magnet and onto the Grimm LEB Cavity (Figure 1). It will require a new vacuum window in order to attain maximal tuning range and high voltage capability and a new center conductor of longer length and a different vacuum window connection than the Grimm center conductor. However, the new center conductor will be essentially identical to the Grimm center conductor in its basic construction and in the way it connects to the stand for support. The tuner is mechanically very similar to high-power stacked circulators built by ANT of Germany and was designed according to ANT's established engineering and design criteria and SSC LEB tuning and power requirements.

The tuner design incorporates thin tiles of ferrite glued using a high-radiation-resistance epoxy to copper-plated stainless steel cooling plates of thickness 6.5 mm with water cooling channels inside the plates. The cooling plates constitute 16 pie-shaped segments arranged in a disk. They are electrically isolated from each other to suppress eddy currents. Five of these disks are arranged in parallel with high-pressure rf contacts between the plates at the outer radius. The end walls are slotted copper-plated stainless steel of thickness 3 mm.

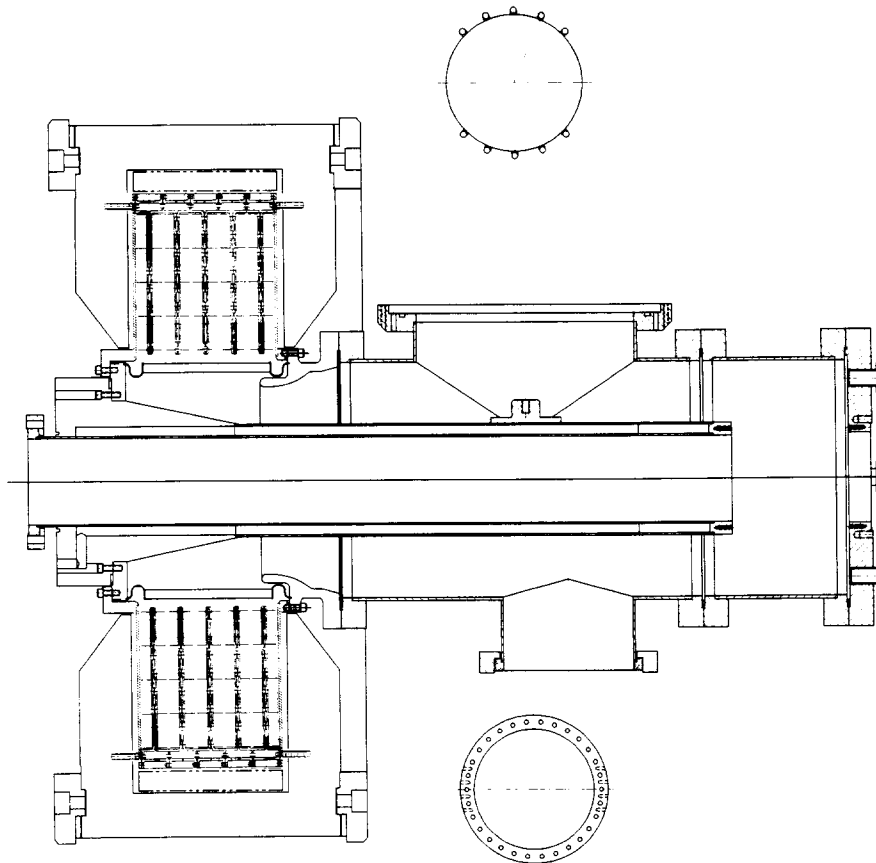

Figure 1. Cross-section of ANT tuner attached to Modified Grimm Cavity.

2.0 STATUS

ANT completed a preliminary mechanical design for this tuner. At that point the tuner design was complete except that we had yet to define the flanges to connect to the cavity. After ANT submitted their tuner design, we also determined that we needed to increase each full air gap between ferrites by 1 mm (0.5 mm for the half-gaps on each end) to lower the maximum field strength. An issue that was raised since is the need to cool the end walls of the tuner. Several methods for accomplishing this have been suggested, with ANT's preference being a suggestion by Uli Weinands to braze small cooling vanes on the outer surface of the end walls that fit between the segmented magnet pole pieces. This design also requires that we drill holes in the magnet pole pieces (outside the ferrite region) to allow water connections to the tuner.

3.0 DESIGN GOALS

The primary goal of this tuner design is to achieve the original goal of 127.5 kV on the gap with a minimum tuning bandwidth of 400 Hz while eliminating water/vacuum joints and water in the rf region of the cavity. A second goal is to utilize only existing commercial technology with proven long-term reliability. Additional goals were (1) simplified construction and assembly, (2) center conductor supported from stand, and (3) reduced cost. Constraints have been added to the prototype cavity because it is necessary for budget and schedule reasons to utilize the existing magnet and tetrode amplifier built for the original LEB cavity. The cavity was analyzed as if it were going to be tested for its absolute maximum frequency range, which would require operating with μ 's ranging up to 3.8. This resulted in higher electric fields in the tuner than would be achieved by an actual production cavity.

In order to capitalize on a design based on low-cost construction and support of the center conductor from the stand that also happened to be in fabrication, we decided to adapt the ANT tuner to the Grimm cavity design.

4.0 SUMMARY OF ANALYSIS RESULTS

Table I summarizes the electric field and power parameters over the frequency range of this cavity. The analysis is performed according to the assumption that the entire cavity is copper-plated.

Table 1. Parameters of LEB/Grimm Cavity with ANT Tuner.

t(s)	f(MHz)	m	V _{gap} (kV)	E _{max} near ferrite (kv/cm)	P _{cw} ferrite (kw)	P _{cw} wall losses (kw)	R (Kohm)	Q	R/Q (kohm)
0.0020	48.1	3.8	33	9.0	2.2	2.1	126	3100	40.6
0.0040	49.7	3.4	90	12.5	9.2	16.4	158	3920	40.3
0.0050	50.5	3.0	108	14.1	5.9	24.8	191	4770	40.0
0.0080	53.0	2.6	113	13.9	5.2	29.2	185	4670	39.6
0.0100	55.7	2.1	120	12.5	4.7	35.7	178	4530	39.3
0.0150	58.0	1.7	123	11.3	4.3	40.0	171	4390	38.9
0.0200	59.3	1.5	127	9.8	4.2	44.0	167	4290	38.9
0.0250	60.0	1.5	125	9.6	3.9	43.4	167	4290	38.9
0.0300	60.0	1.4	116	8.9	3.3	37.3	165	4240	38.9
0.0350	60.0	1.4	100	7.7	2.5	27.8	165	4240	38.9
0.0400	60.0	1.4	78	6.0	1.5	16.9	165	4240	38.9
0.0450	60.0	1.4	50	3.8	0.6	6.9	165	4240	38.9
0.0500	60.0	1.4	15	1.1	0.06	0.6	165	4240	38.9
P _{av}									
P _{av} (relaxed)					1.6	13.2			
					0.5	4.4			

4.1 Tuning Range

The tuning range of the prototype cavity will be about 11 MHz. This is lower than the desired 13.3 MHz because of the space limitations imposed by using the existing magnet. An actual design would require 20% more ferrite (one extra plate) to achieve the desired range. This added length will fit in the existing lattice space.

4.2 Electric Field Strength

For the 127.5 kV cycle, the maximum electric field strength near the ferrite is 14.1 kV/cm. This occurs at approximately 50.5 MHz and 108 kV. ANT's experience is that 18 kV/cm is safe, which means that the cavity voltage could be increased by 25% for testing the safety margin. The maximum tangential electric field at the window is 4.5 kV/cm on the vacuum side, slightly less on the air side. This point occurs far away from the braze joint. Electric fields in the tuner would be further reduced in an actual production design which would be 20% longer due to the extra ferrite.

4.3 Tuning Bandwidth

The results of MAFIA and EMAS runs indicate the tuning bandwidth to be between 400 and 440 Hz. This would be lowered slightly by the addition of another ferrite carrier plate.

4.4 Ferrite Temperature

The maximum difference between the ferrite and cooling water temperature is 2.5°C. There is high thermal conductivity of the thin epoxy layer, but the very low temperature rise is due mostly to the fact that most of the heat is due to resistive losses in the metal plates rather than bulk heating of the ferrite.

4.5 Mechanical Considerations

The thickness of the ferrite tiles is 1.0 cm in the inner radial ring and 1.1 cm in the outer (the electric field drops at larger radius and requires a smaller air gap to maintain a safe field level). The average power density for the 130 kV LEB cycle on the surface of the cooling plates is .6 W/cm², the peak power density occurs near the inner radius of the ferrite and is 1.0 W/cm². Most of the power that must be removed is resistive power generated in the stainless steel plates, rather than in the ferrite. All the mechanical engineering is done by ANT, and according to their design rules all mechanical stresses in the structure including ferrite and glue are safe.

4.6 Non-linear Ferrite Effects

The equations governing nonlinear behavior are as follows

$$\mu_r = 1 + \frac{M_0}{H_0} - \frac{3M_0H_{rf}^2}{8H_0^3}$$

$$\frac{\partial\mu}{\partial H_{rf}} \approx \frac{3M_0H_{rf}}{4H_0^3}$$

and

$$\frac{\partial\mu}{\partial T} \approx \frac{(\partial M_0) / (\partial T)}{H_0} \quad (1)$$

For the LEB tuner, the detuning due to the change in H_{rf} is much greater than that due to temperature change in the ferrite. Because the ANT tuner (configured to fit into the present magnet) needs to be run at higher μ to achieve a maximal tuning range, this would result in a greater detuning due to the nonlinear effects. This would be reduced with a production design that allowed for more ferrite. The maximum nonlinear effects occur at about $t = .004$ s, when the gap voltage is about 90 kV and the frequency is about 49.5 MHz. For this prototype tuner, the nonlinear effects result in an effective change in μ from 3.1 to about 3.08, about twice the effect of the water-cooled tuner.

4.7 Cost

The cost for the prototype tuner including ferrite, water connections, and flanges to meet our specifications is \$85,000. Production tuners would be \$82,500 each. This is very low (ferrite alone for our tuners is about \$110,000). This price included all of the mechanical engineering of the tuner, which was provided by ANT inclusive in the cost of the prototype.

5.0 CONCLUSIONS

The ANT approach promises the achievement of the original goal of 130 kv on the gap with a tuning bandwidth of about 400 Hz while eliminating water/vacuum joints and water in the rf region of the cavity. The result is an extremely conservative design when considering ferrite cooling and has satisfactory electric field stress safety margins despite the artificial constraint imposed by the magnet. It utilizes only existing commercial technology with proven long-term reliability. By utilizing this technology great cost reductions can also be achieved, especially when the cost of engineering is included in the total cost of alternative tuners.

