

FURTHER THOUGHTS ON THE TRANSFER FROM BOOSTER TO CPS

C. Bovet

FURTHER THOUGHTS ON THE TRANSFER FROM BOOSTER TO CPS

C. Bovet

1. Introduction

The beam optics presented in the "beige report"¹⁾ have been calculated by A. Ball and R. Billinge²⁾. It was considered more as a plausibility study than as an optimized solution. The present paper, first discussed in December 1967, emphasises a greater simplicity and gives a basis for the optimisation which has been worked out since then.

2. New scheme for the recombination of the 4 beams

The new scheme shown in Fig. 2 meets the advantages of Bovet's first proposal³⁾ and Asner's variant 1⁴⁾ which has been used in the "beige report".

Comparing Fig. 1 and Fig. 2 one can list the advantages of the new scheme as follows:

- no undue vertical displacement of beam 2 and 3 in the 10 bunch mode,
- suppression of VBM2, VBM3, VSM2, VSM3,
- no physical displacement needed when changing from the 20 bunch mode to the 10 bunch mode.

3. Dispersion matching for the two-turn injection

Figures 3 and 4 show the two-turn injection with $Q = n + \frac{1}{4}$ of respectively an achromatic and a matched beam.

- assuming zero loss one sees that the emittance of the resulting beam is the same in both cases with a slightly higher core density in the achromatic case;
- such a high core density and even a smaller emittance might be obtained with the matched beam by losing 1-2% of the beam intensity on the septum (see dashed area of Fig. 4, revolution 5).

It has therefore been agreed that the achromatic injection possibility will be discarded.

4. β -matching

The individual beams or the vertically added beams are to be matched for the injection into CPS (the wanted β in ss 42 are: $\beta_V = 22$ m, $\beta_H = 12$ m, for single turn injection, and $\beta_H = 12/\sqrt{3}$ m, for the two-turn injection). This matching is provided by the quadrupoles of the matching section (see Fig. 12).

The mismatch resulting from the unavoidable optical action of VBM 1, 2, 3 and VSM 1, 2, 3 (see Fig. 5) may be expressed as an increase of the emittances

	$\Delta E_H/E_H$	$\Delta E_V/E_V$
VBM 1,2 + VSM 1,2 (rectangular magnets)	8%	0
(wedge magnets)	4%	4%
VBM 3 + VSM 3 (rectangular magnets)	14%	0
(wedge magnets)	7%	3%

where the wedge magnets considered are between rectangular and sector magnets (their end shape angle is $\alpha/4$).

A computation showed that a perfect compensation for VBM 3 - VSM 3 action may be achieved with very small variations on Q1, Q2, Q1' and Q2'. On the other hand a compensation for VBM 1,2 - VSM 1,2 action would require the introduction of small doublets but this does not seem worthwhile.

5. Horizontal dispersion matching

Ideally a transfer with dispersion matching is made as shown in Fig. 6a, but practically we have to cope with the following facts:

- an ideal dispersion matching would require all the length available for the transfer,
- recombination and β -matching also need the total length,
- there is an additional angle of 9° in the middle (see Fig. 6b).

One then has to abandon the spatial separation between β -matching and dispersion matching.

Let us suppose the dispersion vector \vec{D} has to be as shown in Fig. 7b. The matching is done in two steps:

- i) with the lens L (Fig. 8) the beam is shaped so as to give the right "dispersion invariant" after the bending B (Fig. 7a);
- ii) subsequent β -matching not only provides the proper β , but also the right betatronic phase φ (see Fig. 7b).

For a complete flexibility the β -matching then needs six quadrupoles. But for the 20 bunch mode (first stage) four quadrupoles might perhaps be sufficient.

There will be no dilution due to the horizontal dispersion.

For the vertical dispersion nothing can be tuned.

6. Kicker jitter

The increased emittance is given by

$$\frac{\delta\theta}{E} = \frac{\delta\alpha}{b} = \frac{a}{E} \frac{\delta\alpha}{\alpha} \alpha \quad (1)$$

where α is the kicker deflexion, a and b are defined in Fig. 9a.

As an illustration of this effect let us consider a beam where $E = 40 \pi \mu \text{ rad.m}$, $a = 40 \text{ mm}$, $\alpha = 10 \text{ mrad}$ and $\delta\alpha/\alpha = \pm 1\%$: $\Delta E/E = 10\%$.

Therefore one has to minimize rather carefully the product $a \cdot \alpha$ for the beam in the kickers.

7. Vertical addition

The formulae giving the circumscribing ellipse in the general case of Fig. 9b have been derived.

Describing the incoming ellipse by ϵ_1 , L_1 , S_1 (see Fig. 9a), the distance between the centres of the beams $2df$ (see Fig. 9b), the circumscribing ellipse parameters ϵ_2 , L_2 , S_2 are as follows:

$$\left. \begin{aligned} \epsilon_2 &= R_1 R_2^2 \epsilon_1 \\ L_2 &= \frac{R_1 L_1 (L_1^2 + S_1^2)}{R_1^2 S_1^2 + L_1^2} \\ S_2 &= \frac{R_1^2 S_1 (L_1^2 + S_1^2)}{R_1^2 S_1^2 + L_1^2} \end{aligned} \right\} \quad (2)$$

where

$$R_1 = \sqrt{(3f + \sqrt{f^2 + 8}) / (-f + \sqrt{f^2 + 8})}$$

$$R_2 = \frac{1}{2} \sqrt{4 - f^2 + f \sqrt{f^2 + 8}} \quad .$$

Two curves giving the values of $R_1 \cdot R_2$ and R_2 are drawn in Fig. 10.

Then the required angle α , between the two beams at the addition point is

$$\alpha = f d S_1 / [L_1 (H + \sqrt{H^2 - 1}) - 1] , \quad (3)$$

where

$$H = (L_1^2 + S_1^2 + 1) / 2 L_1 .$$

Other calculations were made under the assumption of a uniform density in the phase plane, which give:

- i) the increase in emittance E/E_0 ,
- ii) the loss of particles on the septum p , and
- iii) the loss of density (after filamentation) $D/D_0 = (1 - p)2E_0/E$, as functions of the separation parameter f and the septum thickness parameter e .

The curves are shown in Fig. 11.

8. Beam layout

Figure 12 shows the arrangement of the elements. Major changes are:

- dropping the $3,791^\circ$ bend on the Linac line
- reducing from 4° to 3° the ejection angle
- dropping the $3,052^\circ$ horizontal bending
- joining the bendings for beam stopper and dispersion matching, presently $+ 25^\circ$, $- 10^\circ$
- replacing the first focusing triplet by a doublet
- other changes have been mentioned in Chapter 2.

9. Aims for optimization of the transfer

- Rather large V-size at DSM
- minimum $a \cdot \alpha$ in kickers $K_{1,2}$ (for 20 bunch mode only)
- small enough H-size in $K_{1,2}$
- small V-size at VSM 3 (especially for the 10 bunch mode)
- minimum $a \cdot \alpha$ in kicker K_3
- H-dispersion matching at HBM.

ACKNOWLEDGEMENTS

I would like to thank Mr G. Guignard who performed the calculations with very great care.

Distribution (open)

SI Scientific Staff

REFERENCES

- 1) Study Group for CPS Improvements, The Second Stage CPS Improvement Study (800 MeV Booster Synchrotron), MPS/Int. DL/B 67-19, 3.10.1967 (Beige Report).
- 2) A.E. Ball, R. Billinge, Beam Optics for the Transfer from the Booster to the CERN PS, MPS/Int. MA/B 67-24, 29.12.1967.
- 3) C. Bovet, Beam Junction in the Transfer from Booster to CPS, MPS/DL/B-Note 67-5, 20.4.1967.
- 4) A. Asner, Booster Fast Extraction, Beam Addition and PS-Injection Systems with Magnet Parameters, MPS/Int. MA/B 67-11, 6.11.1967.

20-bunch mode

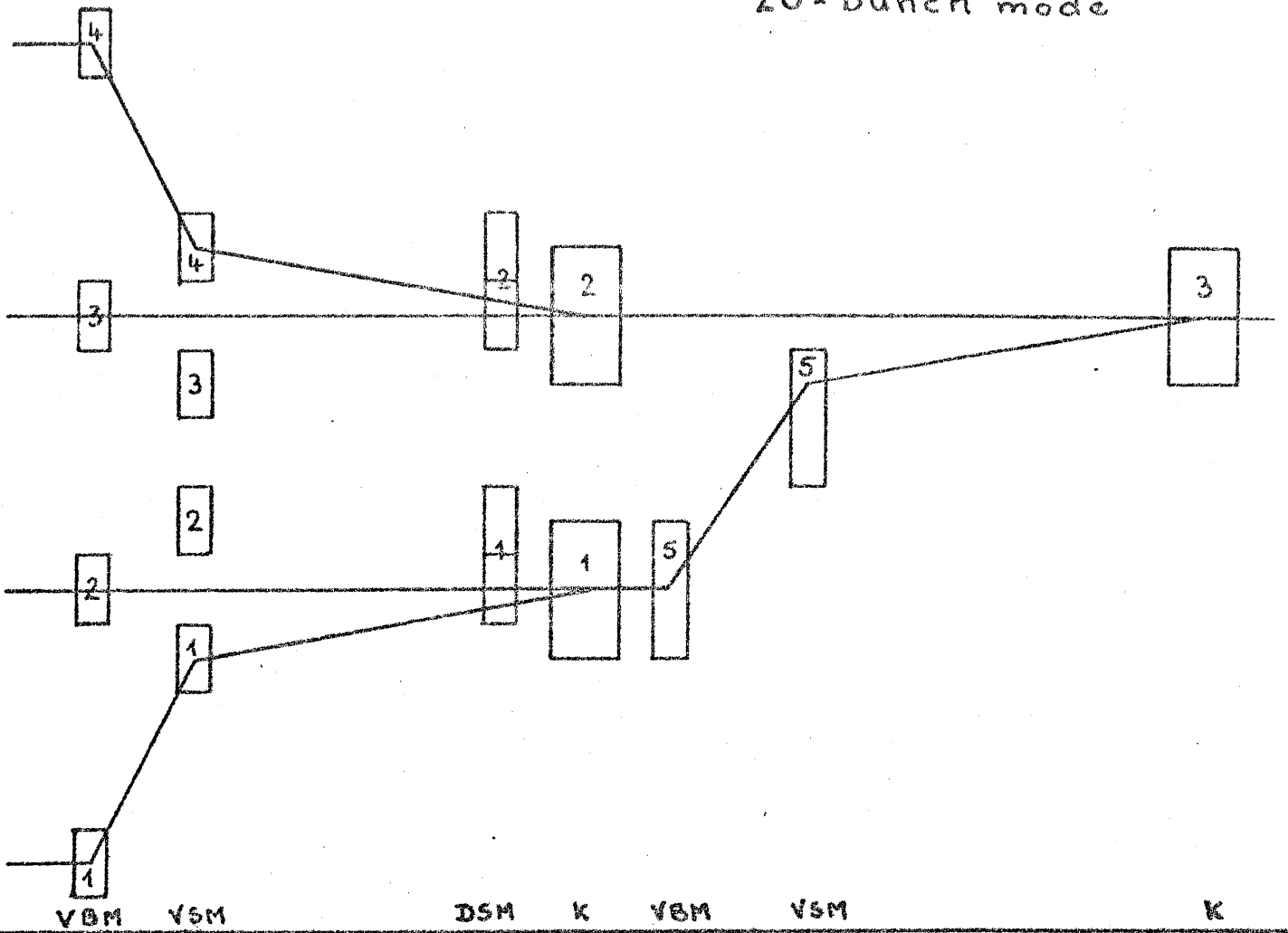

10-bunch mode

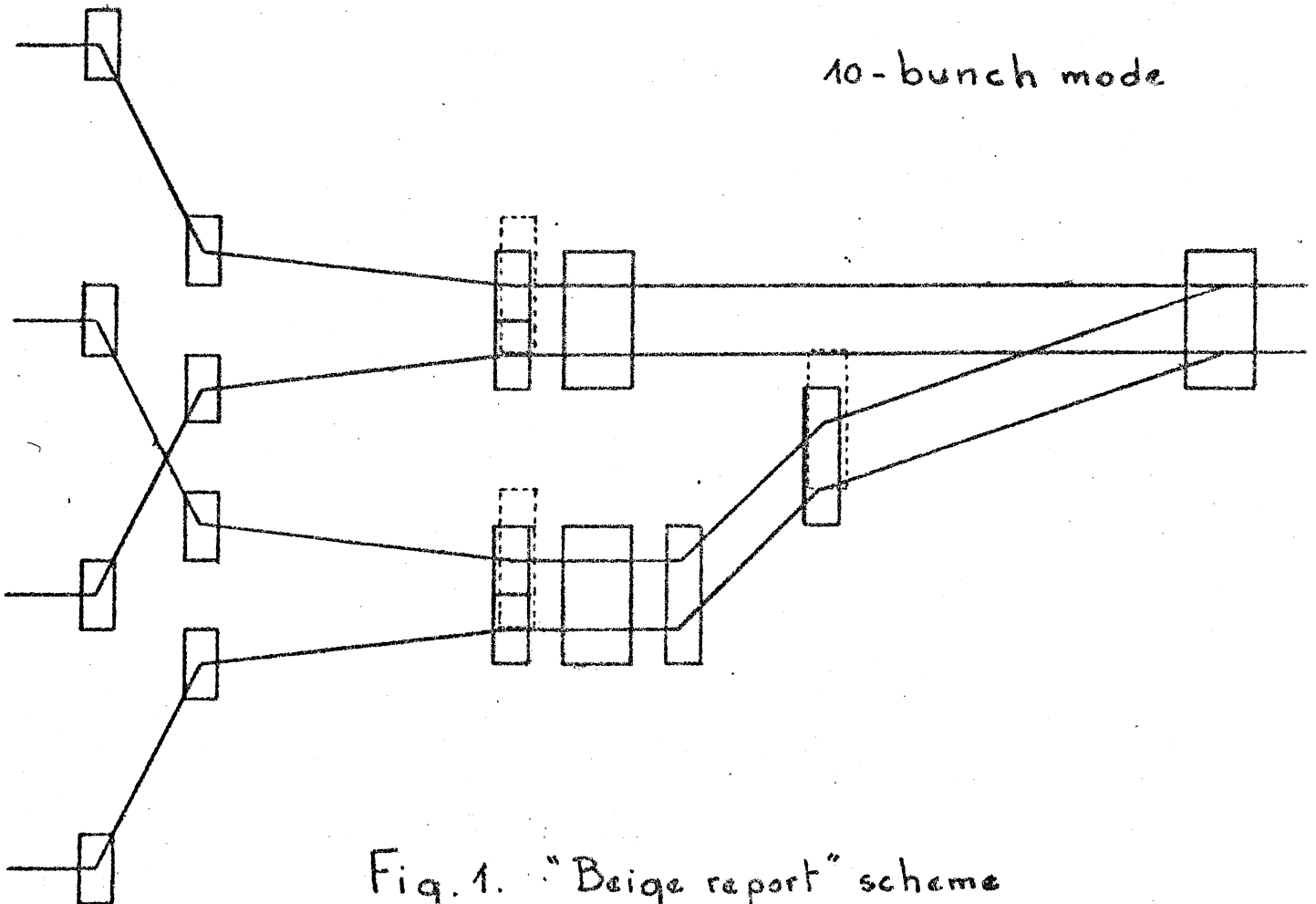
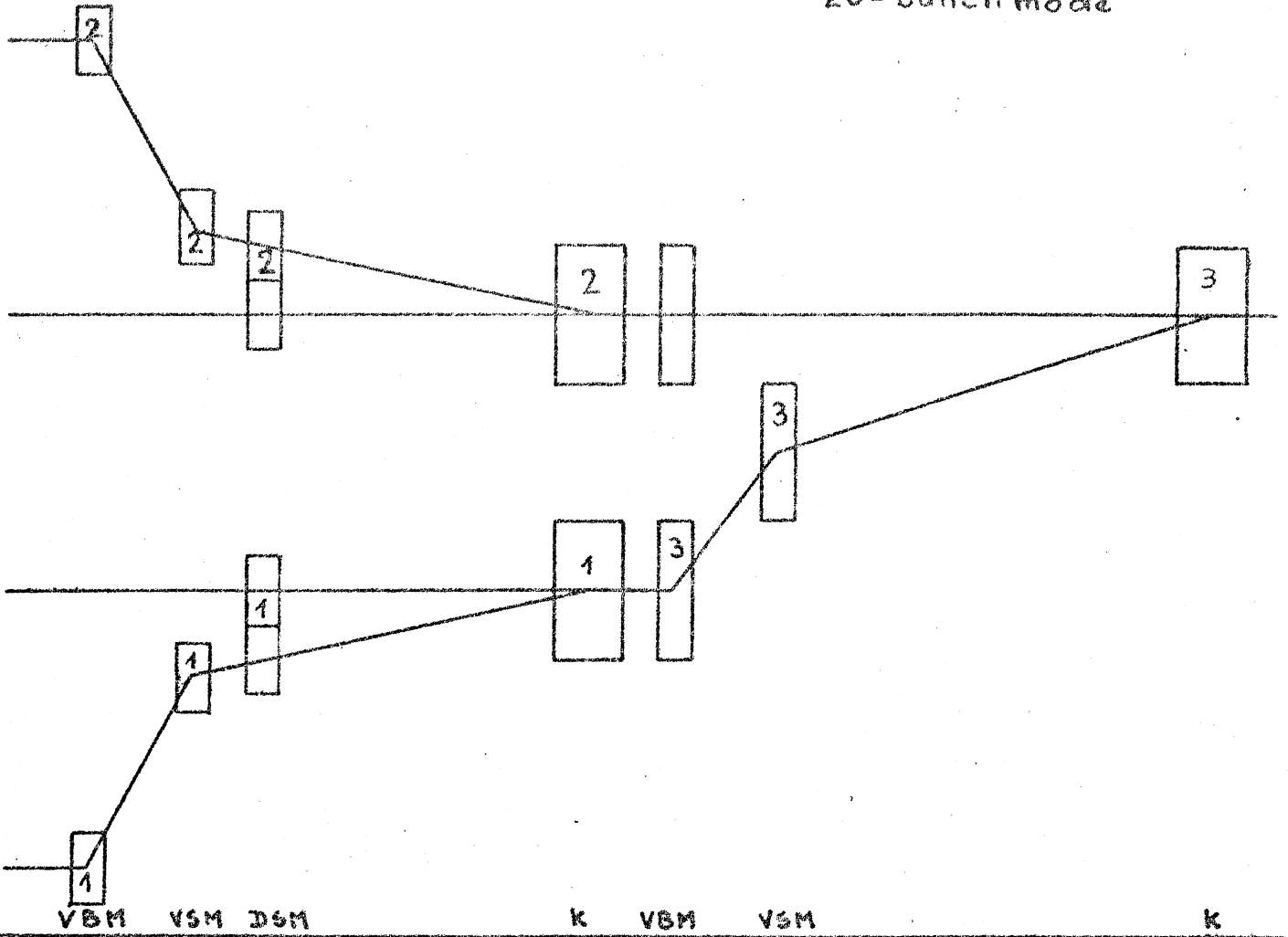

Fig. 1. "Beige report" scheme

20-bunch mode



10-bunch mode

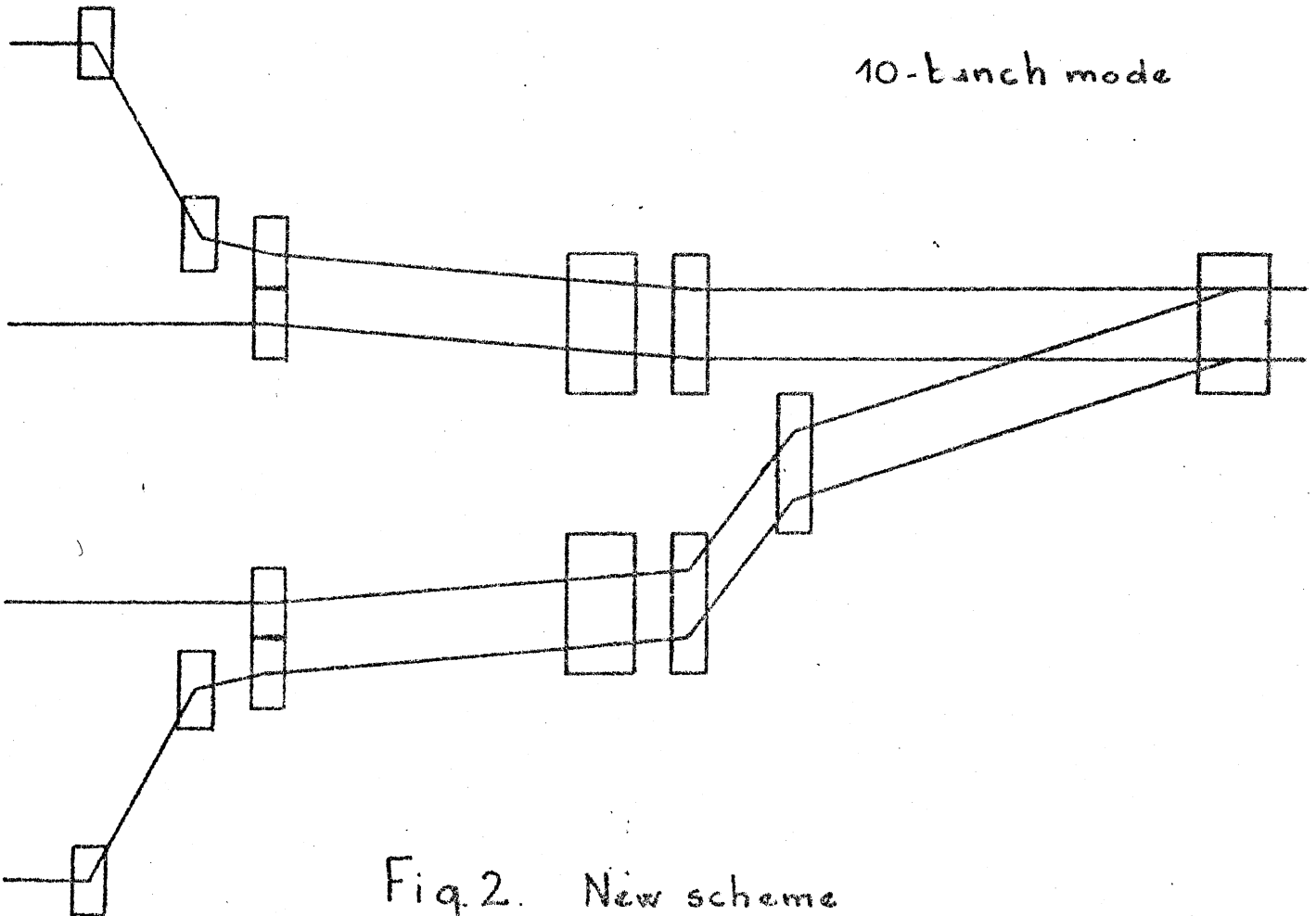
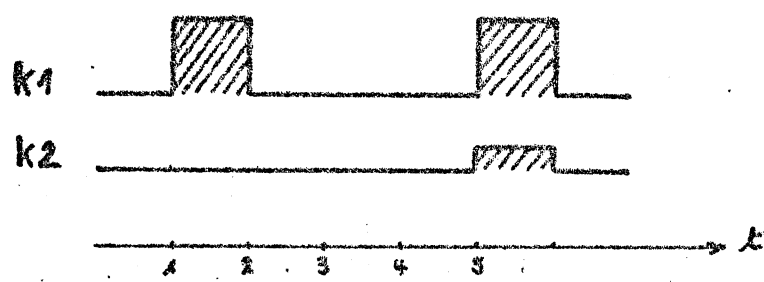
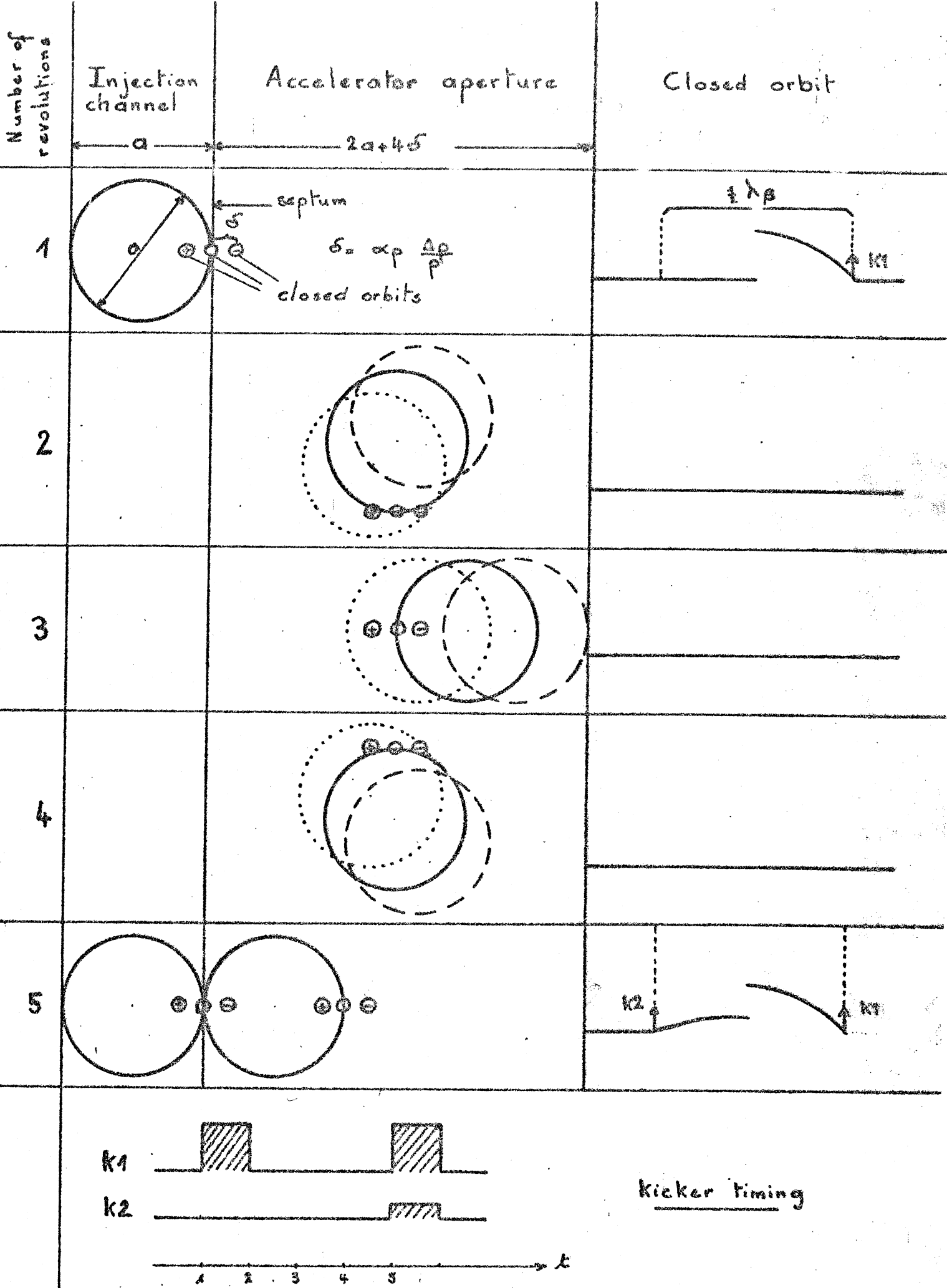

Fig. 2. New scheme



kicker timing

Fig. 3. Achromatic beam injection

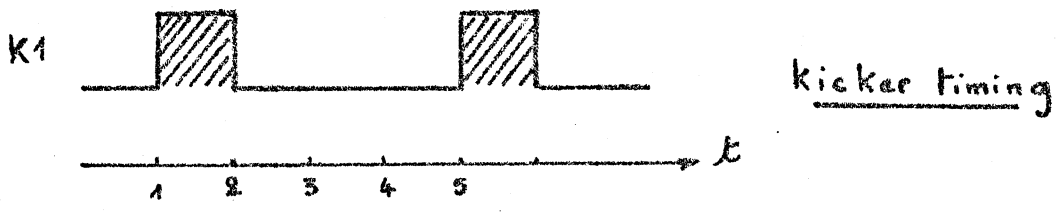
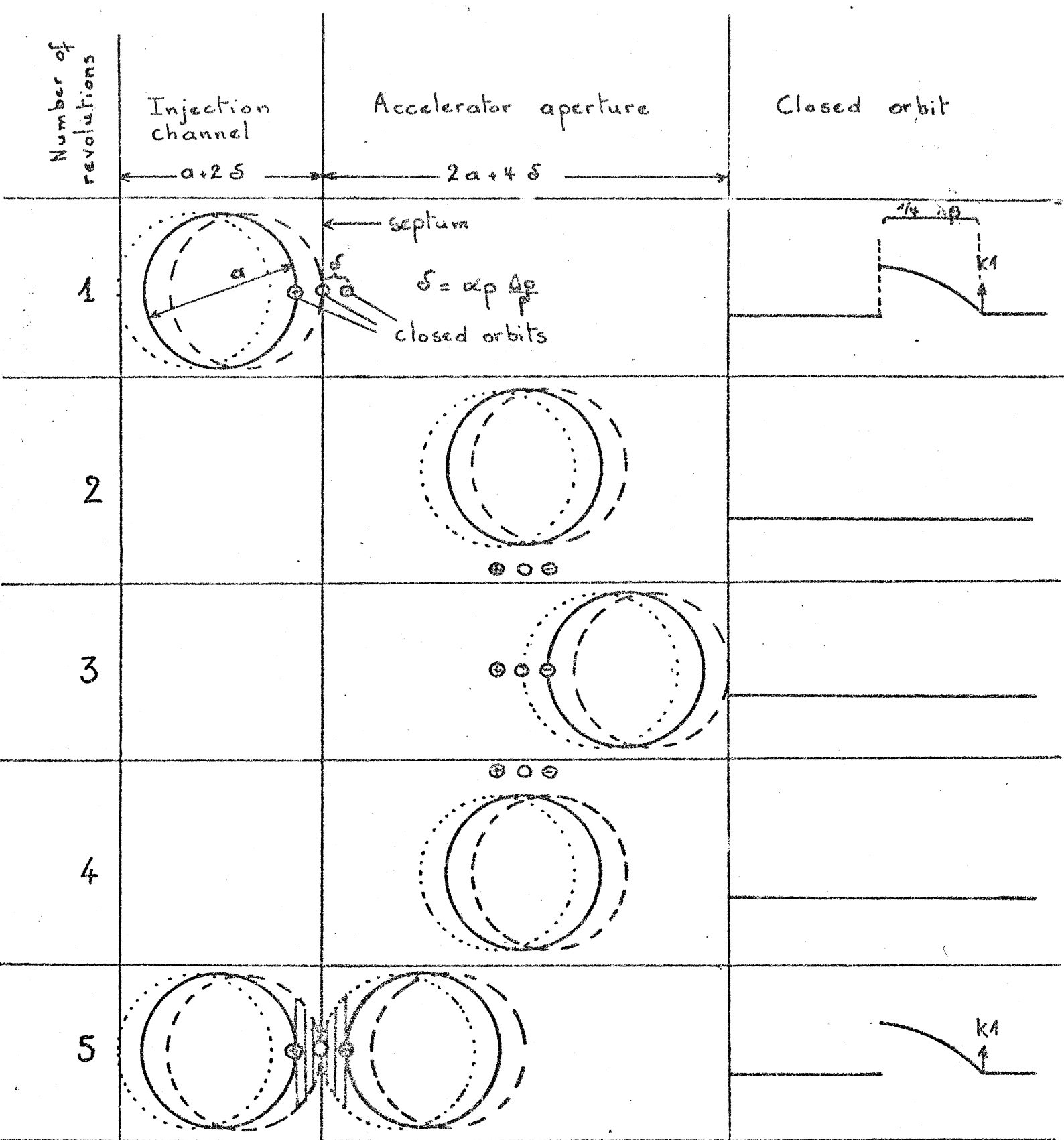

Fig. 4. Matched beam injection

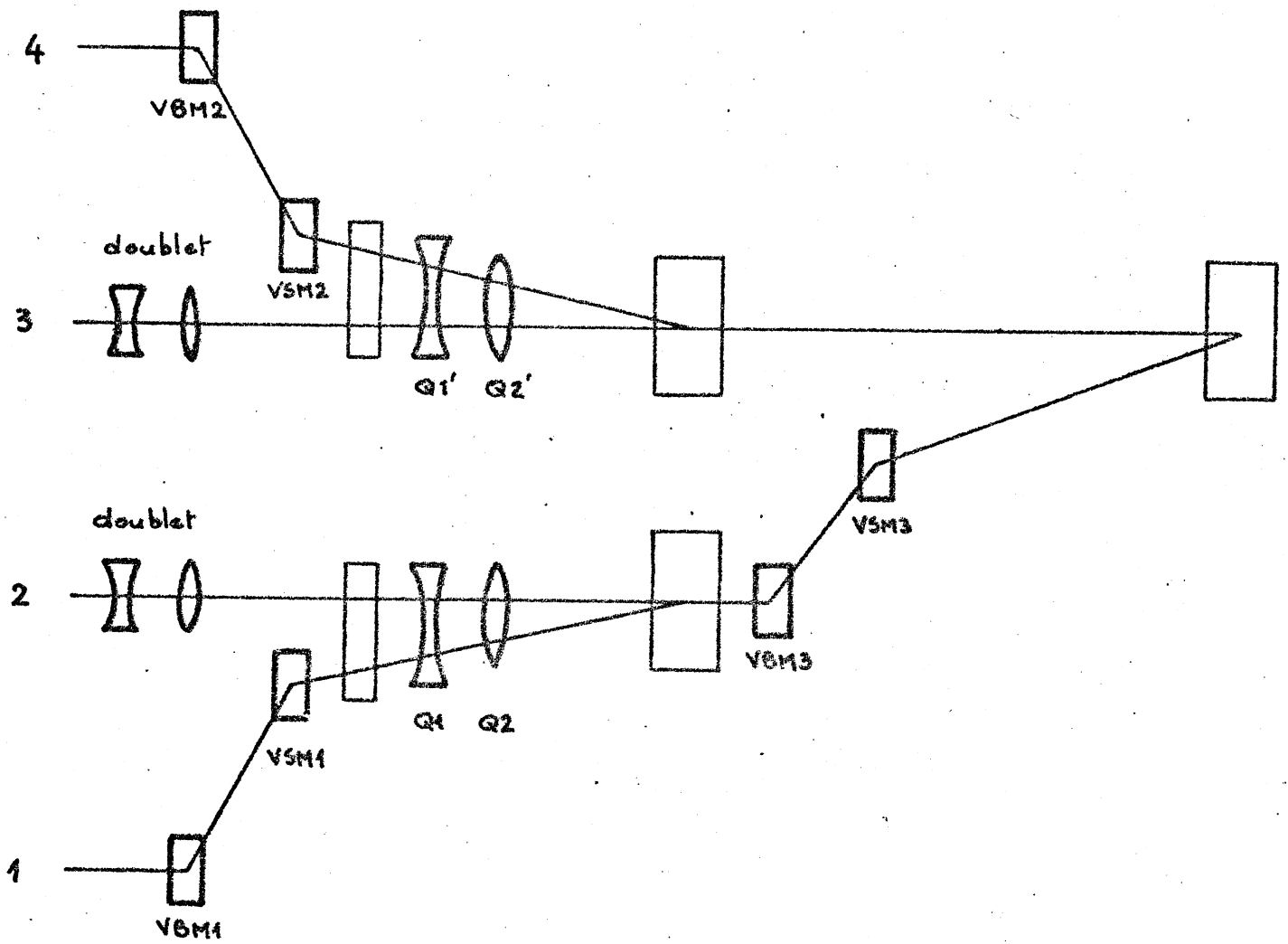

Fig. 5. Optical mismatch compensation

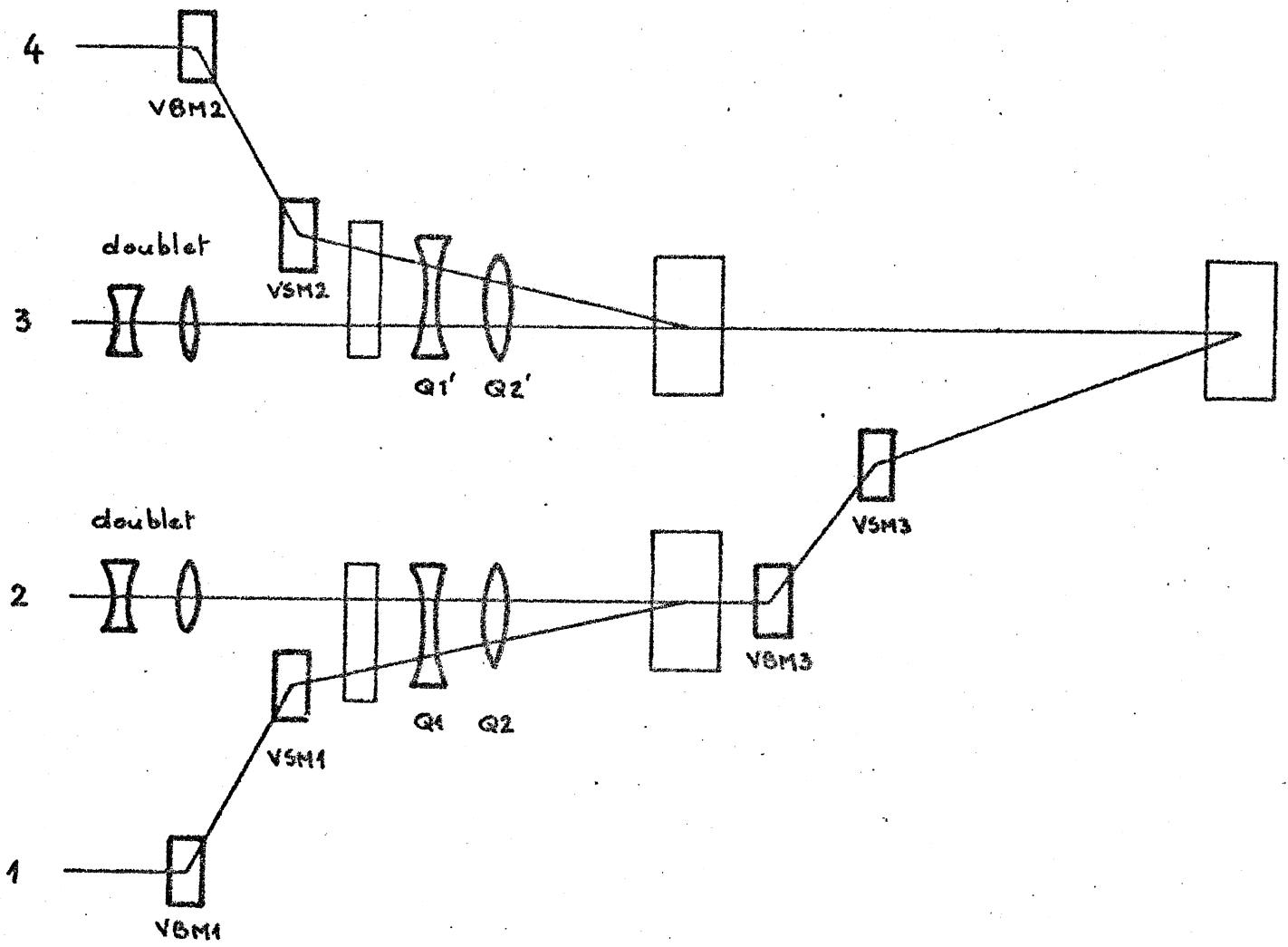

Fig. 5. Optical mismatch compensation

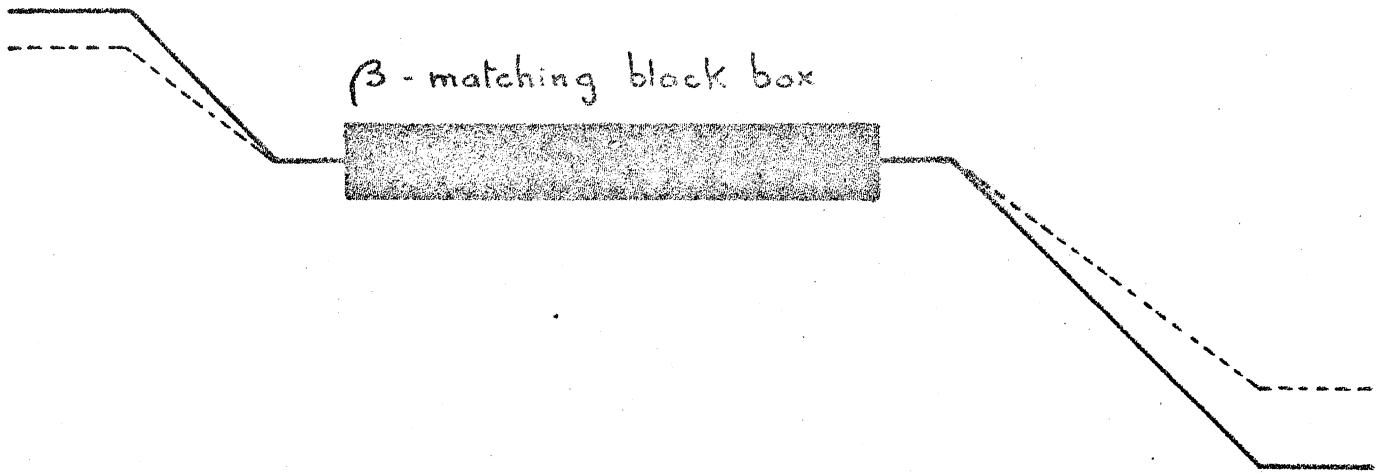

Fig. 6a. Ideal case

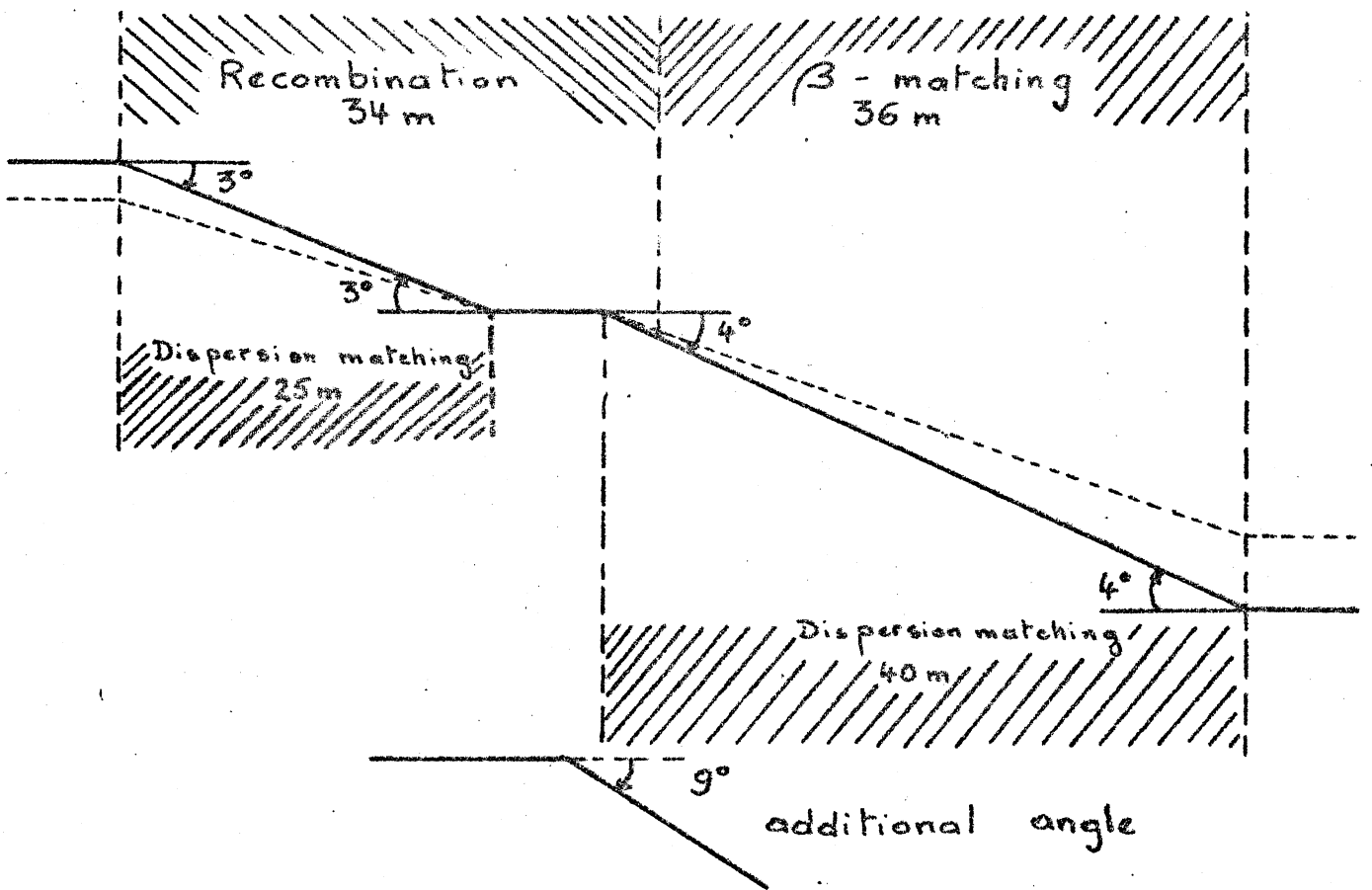
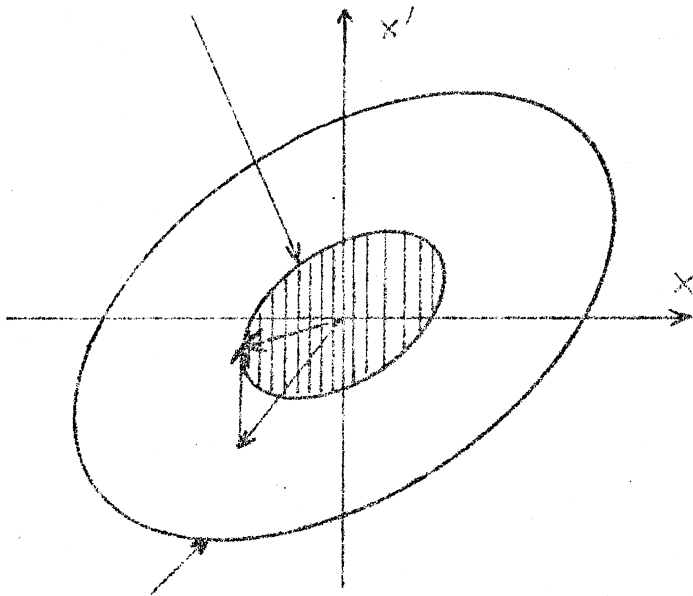
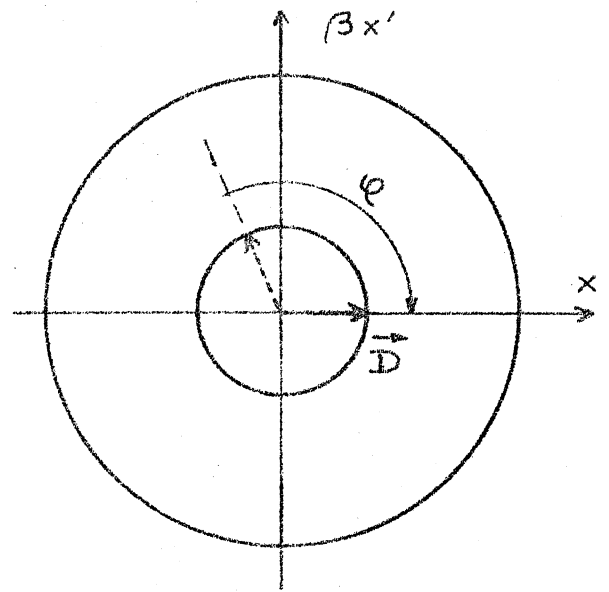

Fig. 6b. Actual situation

"Dispersion invariant"



Beam emittance a.



b

Fig. 7. Dispersion matching diagrams

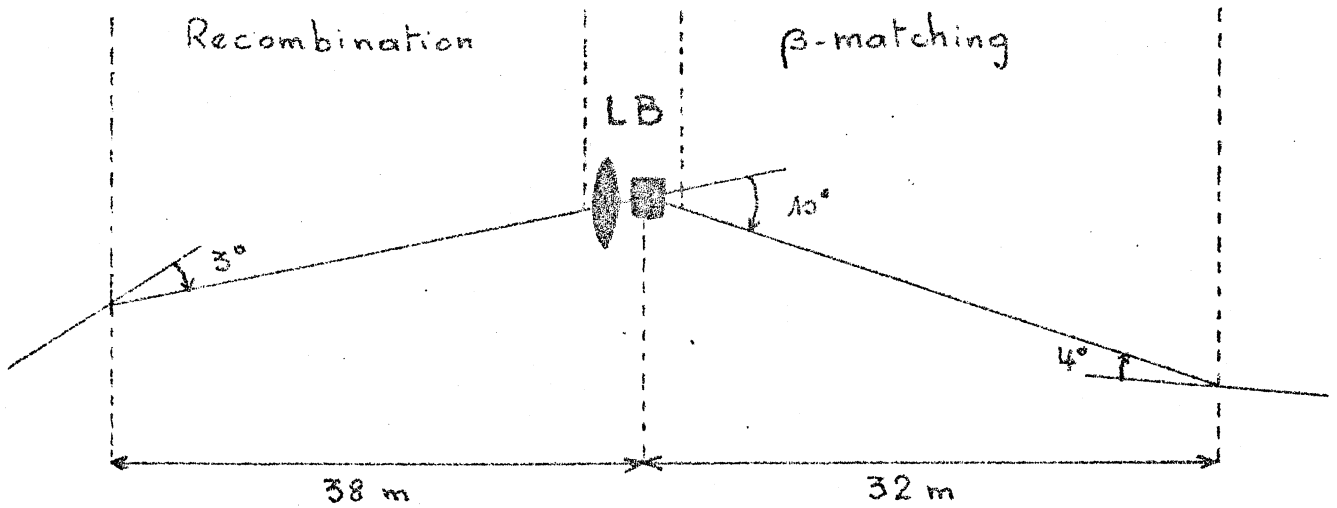

Fig. 8. Layout for dispersion matching

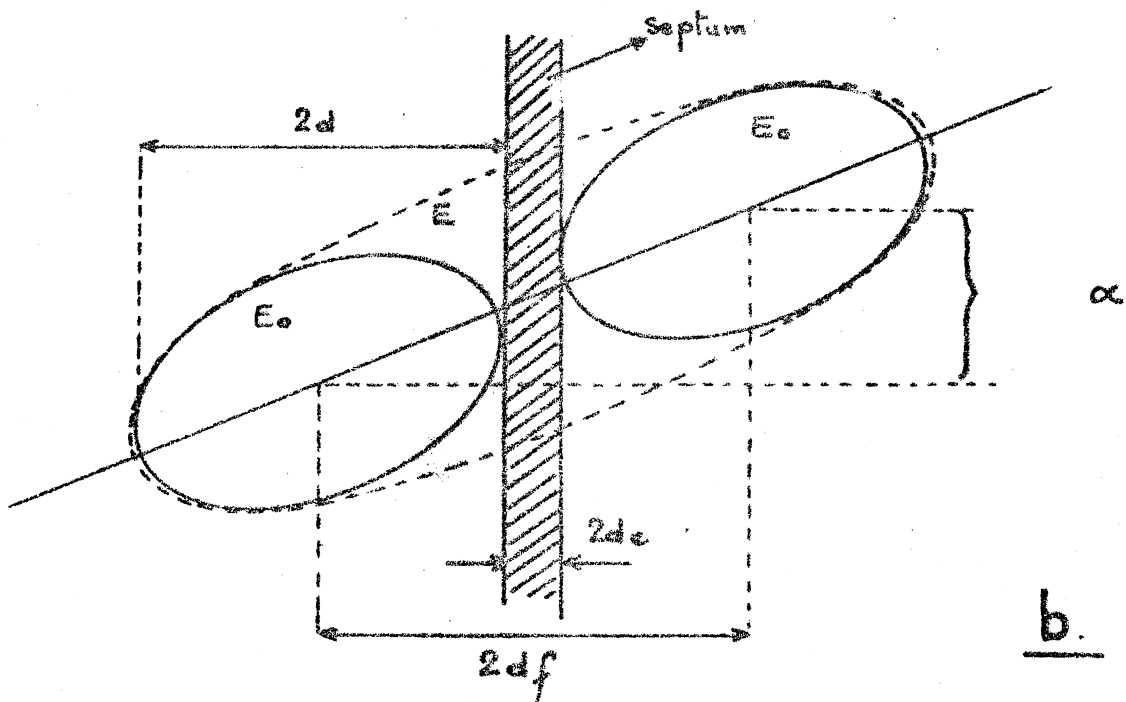
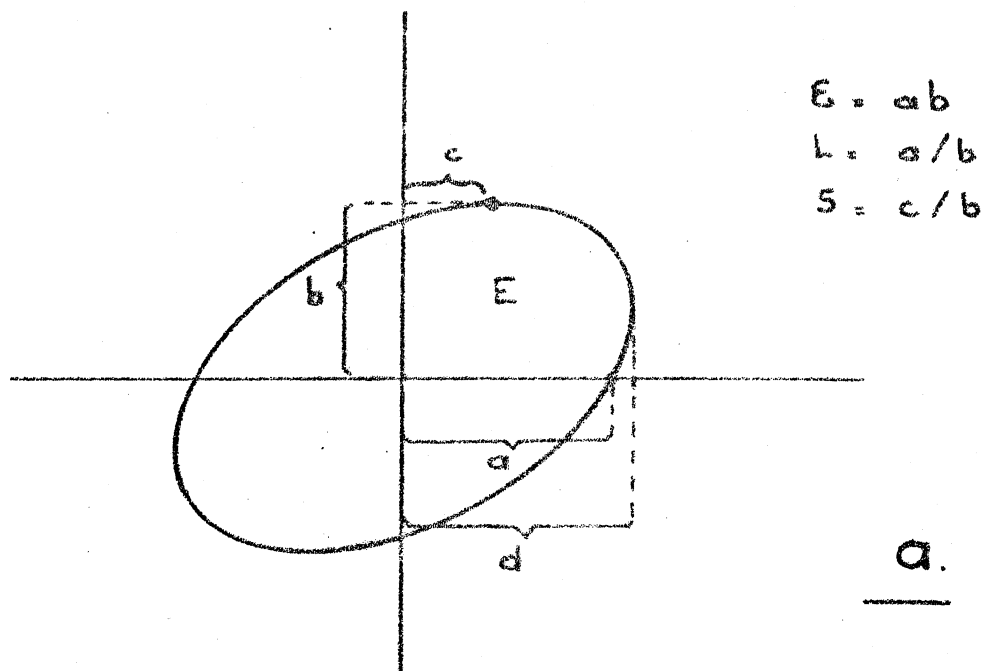

Fig. 9. Phase plane diagram for the vertical addition

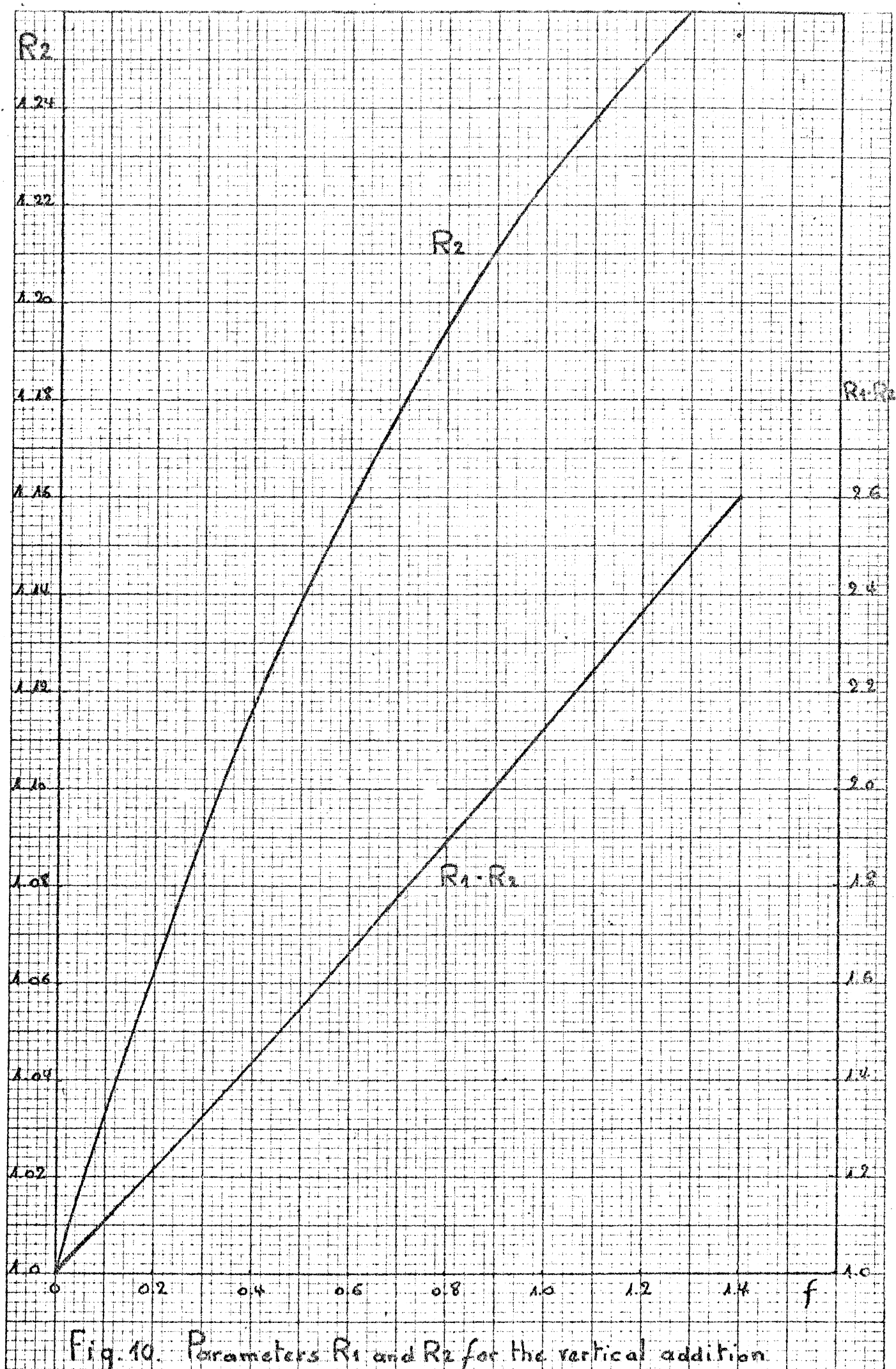
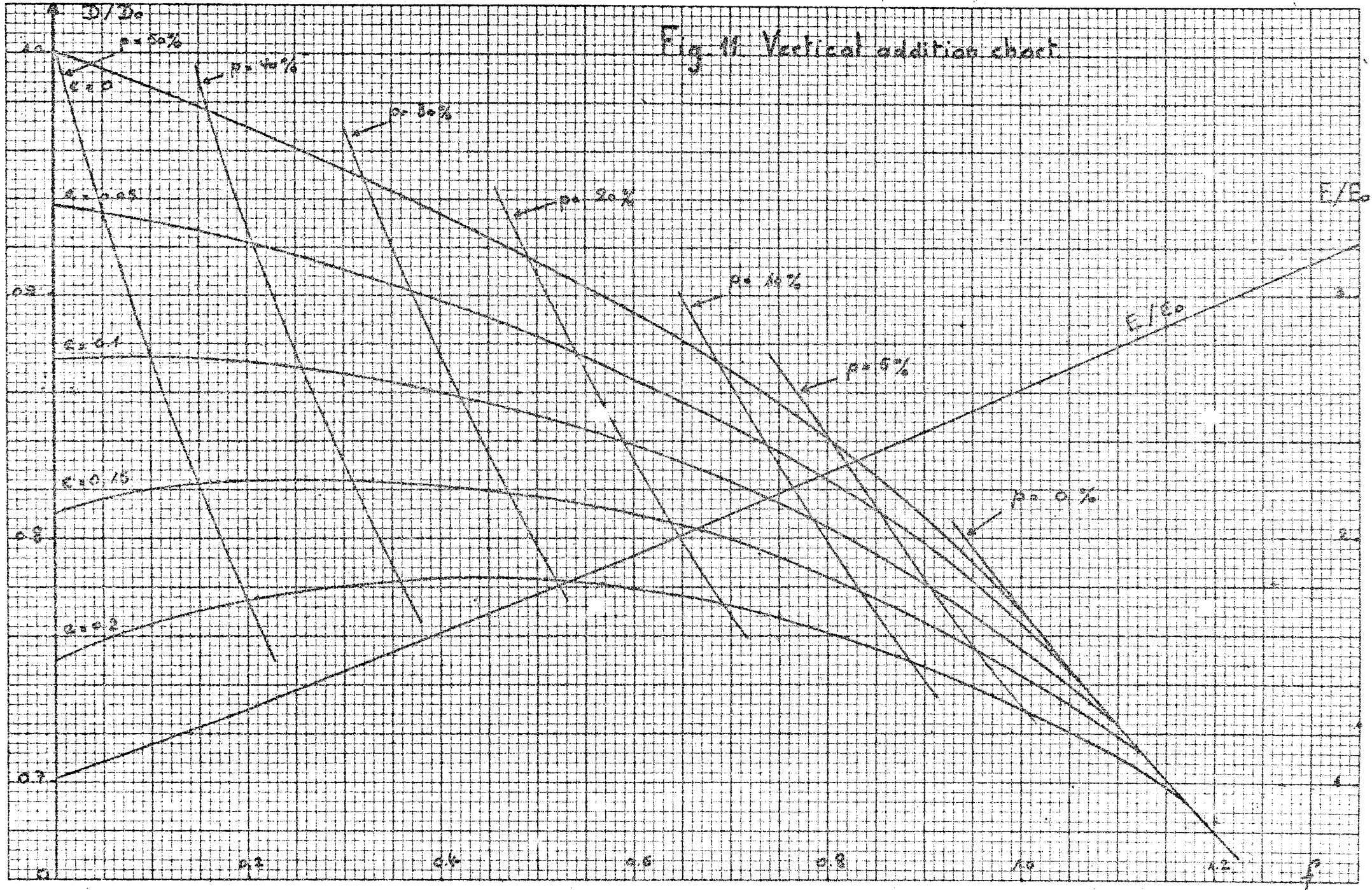

Fig. 10. Parameters R_1 and R_2 for the vertical addition.

Fig. 11 Vertical addition chart



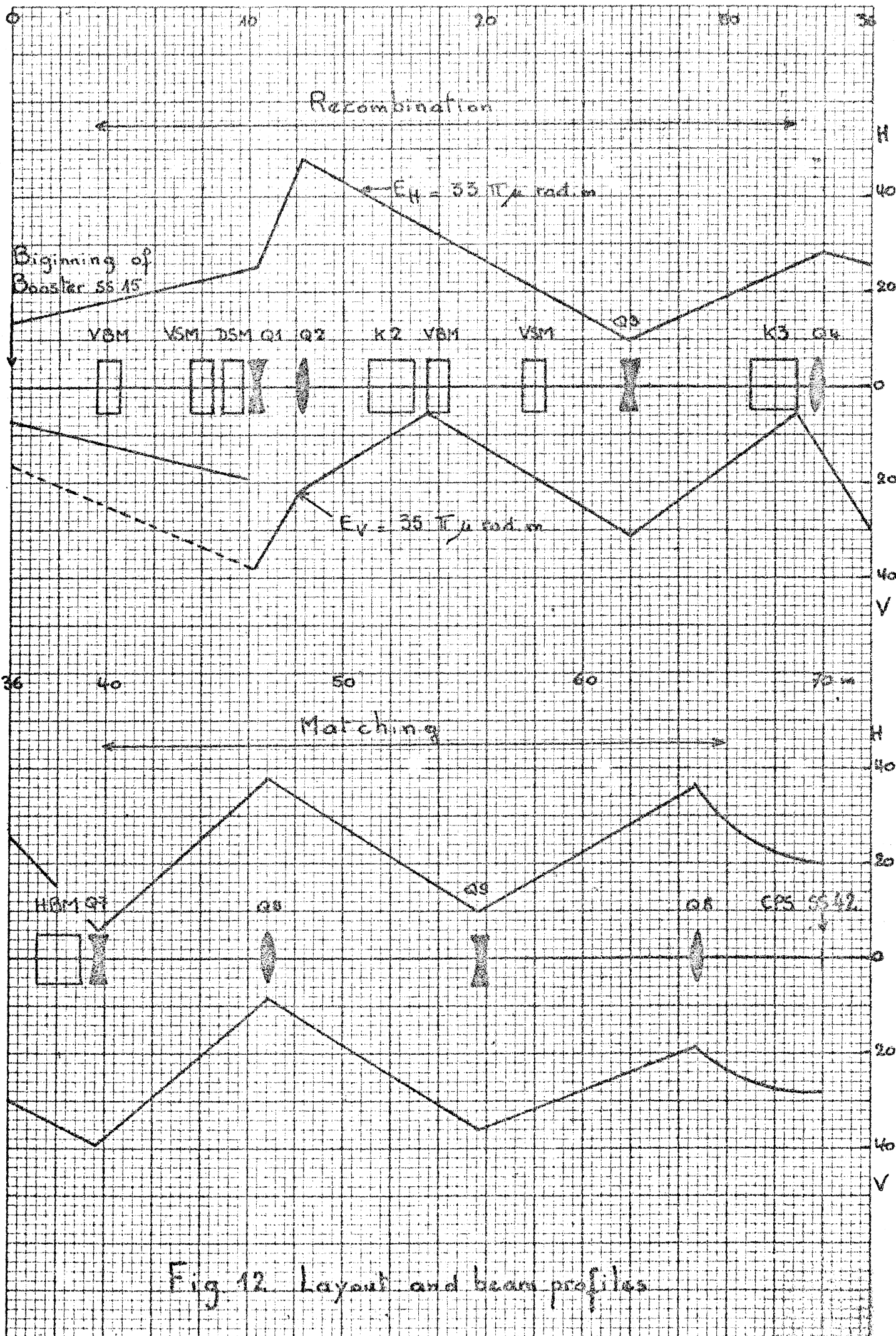

Fig 12. Layout and beam profiles