



Peer Reviewed

Title:

A search for excited electrons with the Compact Muon Solenoid detector

Author:

[Sudano, Elizabeth Jane Dusinberre](#)

Acceptance Date:

2012

Series:

[UC San Diego Electronic Theses and Dissertations](#)

Degree:

Ph. D., [UC San Diego](#)

Permalink:

<http://escholarship.org/uc/item/8vw5p9z9>

Local Identifier:

b7322565

Abstract:

A search for excited electrons using the CMS detector at the LHC with 36 pb^{-1} of proton-proton collision data recorded at $\sqrt{s} = 7 \text{ TeV}$ is presented. The search is performed for associated production of an electron and an excited electron followed by the decay of the excited electron to an electron and a photon for a final state of $ee[\gamma]$. No excess of events above the standard model expectation is observed. Interpreting the results in the context of production via novel four-fermion contact interactions and the subsequent decay via electroweak processes, upper limits on the production cross section are set. The exclusion region in the compositeness scale, $[\Lambda]$, and excited electron mass, M_{e^*} , parameter space is extended beyond previously established limits. For $[\Lambda] = 2 \text{ TeV}$, excited electron masses are excluded below $760 \text{ GeV}/c^2$ are excluded at the 95% confidence level. The cross sections for masses between 200 and $1500 \text{ GeV}/c^2$ are limited to be less than $0.21 - 0.16 \text{ pb}^{-1}$.

Copyright Information:

All rights reserved unless otherwise indicated. Contact the author or original publisher for any necessary permissions. eScholarship is not the copyright owner for deposited works. Learn more at http://www.escholarship.org/help_copyright.html#reuse



UNIVERSITY OF CALIFORNIA, SAN DIEGO

**A search for excited electrons with the Compact Muon Solenoid
detector**

A dissertation submitted in partial satisfaction of the
requirements for the degree
Doctor of Philosophy

in

Physics

by

Elizabeth Jane Dusingerre Sudano

Committee in charge:

Professor James Branson, Chair
Professor Kenneth Inriligator
Professor Katja Lindenberg
Professor David Miller
Professor Avi Yagil

2012

Copyright
Elizabeth Jane Dusingerre Sudano, 2012
All rights reserved.

The dissertation of Elizabeth Jane Dusingherre Sudano is approved, and it is acceptable in quality and form for publication on microfilm and electronically:

Chair

University of California, San Diego

2012

DEDICATION

For Jack and those who might join him.

TABLE OF CONTENTS

	Signature Page	iii
	Dedication	iv
	Table of Contents	v
	List of Figures	vii
	List of Tables	x
	Acknowledgements	xii
	Vita and Publications	xiii
	Abstract of the Dissertation	xiv
Chapter 1	Introduction	1
Chapter 2	The Standard Model of Particle Physics and Beyond	2
	2.1 An Overview of Particles and Forces	3
	2.2 The Standard Model	8
	2.3 Excited Electrons	12
Chapter 3	The Large Hadron Collider and the Compact Muon Solenoid	15
	3.1 The Large Hadron Collider	16
	3.2 The Compact Muon Solenoid	18
	3.2.1 The CMS Coordinate System	19
	3.2.2 The Layout of CMS	19
	3.3 The Tracking System	21
	3.4 The Electromagnetic Calorimeter	24
	3.4.1 ECAL Performance and Calibration	26
	3.5 The Hadronic Calorimeter	28
	3.6 The Muon System	29
	3.7 The Trigger and Data Acquisition Systems	31
	3.7.1 The Level 1 Trigger	33
	3.7.2 Data Acquisition	35
	3.7.3 High-Level Trigger	37
	3.7.4 Data Quality Monitoring	38
	3.8 Beyond the DAQ	39

Chapter 4	Doing Physics At CMS	43
	4.1 Particle Physics Analysis Software	44
	4.1.1 Generation	45
	4.1.2 Simulation	46
	4.1.3 Reconstruction	46
	4.2 A Few Notes on Proton-Proton Collisions	47
	4.3 Photon and Electron Reconstruction	48
	4.3.1 Electromagnetic Clusters	48
	4.3.2 ECAL Anomalous Signals	49
	4.3.3 Photon Reconstruction	49
	4.3.4 Electron Reconstruction	50
Chapter 5	Event Selection	52
	5.1 Data and MC Samples	52
	5.2 High Level Trigger	53
	5.3 Object Selection	55
	5.3.1 Photon Identification	56
	5.3.2 Electron Identification	60
	5.4 Event Selection	62
	5.5 Backgrounds	67
	5.5.1 Irreducible Standard Model Backgrounds	67
	5.5.2 Reducible Backgrounds	70
	5.5.3 Control Regions	73
Chapter 6	Systematic Uncertainties	79
	6.1 ECAL Energy Scale	79
	6.2 Luminosity	80
	6.3 Data Driven Estimate Uncertainties	80
	6.4 Theoretical Errors	81
	6.5 Signal Modeling Error	82
Chapter 7	Results	83
	7.1 $e\gamma$ Pair Selection and Final Cut	83
	7.2 Event Yields and Limit Setting	84
Appendix A	Other Analysis Options	91
	A.1 Z Mass Window Removal	91
	A.2 Pixel Veto	93
	A.3 Endcap Photons	95
	A.4 Both Mass Combinations	98
Bibliography	101

LIST OF FIGURES

Figure 2.1: A table of the elementary particles.	5
Figure 2.2: The allowed interactions of the Standard Model. Note: in diagram (a) the “ f ” does not include the neutrinos for the interaction with the photon (γ).	7
Figure 2.3: Excited electrons can be produced singly via novel contact interactions.	13
Figure 2.4: Excited electrons can also be produced (or decay) via interactions with ordinary gauge bosons (here the photon).	13
Figure 2.5: Plot of branching fractions to various final states as a function of M/Λ	14
Figure 3.1: The CERN accelerator complex	17
Figure 3.2: The Compact Muon Solenoid	20
Figure 3.3: The layout of a quarter of the tracker.	22
Figure 3.4: The amount of material making up the tracker as a function of η	23
Figure 3.5: A $r - z$ depiction of a quarter of the CMS ECAL.	24
Figure 3.6: A $r - z$ depiction of a quarter of the CMS HCAL. Different colors denote regions read out separately.	29
Figure 3.7: A $r - z$ depiction of a quarter of the CMS Muon system. Different colors denote the different types of detectors. Below $r = 300$ cm the blue shows the HCAL, the green the ECAL, and the pink the two layers of silicon trackers.	30
Figure 3.8: A schematic of the TriDAS of CMS	32
Figure 3.9: The layout of the L1 system	34
Figure 3.10: A detailed schematic of the DAQ system [46].	36
Figure 3.11: An example event display highlighting the tracker and calorimeter systems. The green lines show reconstructed tracks, the red are ECAL deposits, the blue HCAL deposits, and the yellow reconstructed jets (actually electrons and photons in this event).	41
Figure 3.12: A schematic of the path data (and MC) take through the tiered computing system	42
Figure 5.1: Single particle and complete final state acceptances at generator level.	56
Figure 5.2: A schematic of the isolation area for tracker and ECAL isolations. The blue shaded area shows the region included in the sums. Tracks or hits in the white area are subtracted from the total.	58
Figure 5.3: Di-electron mass spectrum with QCD background estimated from data.	63

Figure 5.4:	Di-electron mass spectrum for events passing the full selection. The signal shown here is $M_{e^*} = 200 \text{ GeV}/c^2$	65
Figure 5.5:	E_T of photons passing full event selection. No cut on the $e\gamma$ invariant mass is applied. The signal shown here is $M_{e^*} = 200 \text{ GeV}/c^2$	65
Figure 5.6:	Di-electron mass spectrum for events with an ultra-loose photon. Signal is $M_{e^*} = 200 \text{ GeV}/c^2$	67
Figure 5.7:	Event display for the highest M_{ee} event passing the full event selection. $M_{ee} = 194 \text{ GeV}/c^2$; $M_{e\gamma}^{Max} = 123 \text{ GeV}/c^2$; $M_{e\gamma}^{Min} = 92 \text{ GeV}/c^2$; $M_{ee\gamma} = 248 \text{ GeV}/c^2$. Here the object identified as the photon is actually an electron.	68
Figure 5.8:	Ultra-loose photon identification and isolation distributions. . .	75
Figure 5.9:	Maximum $e\gamma$ mass for events with loosened photon selection. The signal is $M_{e^*} = 200 \text{ GeV}/c^2$	76
Figure 5.10:	Photon E_T spectrum with loosened photon selection. The signal is $M_{e^*} = 200 \text{ GeV}/c^2$	76
Figure 5.11:	$e\gamma$ invariant mass spectrum. Fake rate applied to data.	77
Figure 5.12:	$e\gamma$ invariant mass spectrum. Fake rate applied to MC.	77
Figure 5.13:	Photon E_T spectrum in $e\gamma$ events. Fake rate applied to data. . .	77
Figure 5.14:	Photon E_T spectrum in $e\gamma$ events. Fake rate applied to MC. . .	77
Figure 5.15:	Electron p_T spectrum in $e\gamma$ events. Fake rate applied to data. . .	78
Figure 5.16:	Electron p_T spectrum in $e\gamma$ events. Fake rate applied to MC. . .	78
Figure 7.1:	Invariant mass distribution for the choice of the lower invariant mass $e\gamma$ pair. Signal is $M_{e^*} = 200 \text{ GeV}/c^2$	84
Figure 7.2:	Invariant mass distribution for the choice of the higher invariant mass $e\gamma$ pair. Signal is $M_{e^*} = 200 \text{ GeV}/c^2$	84
Figure 7.3:	Invariant mass distribution for the choice of the higher invariant mass $e\gamma$ pair. Signals are $M_{e^*} = 200, 400, 600 \text{ GeV}/c^2$	86
Figure 7.4:	95% confidence level exclusion limits in the Λ - M_{e^*} parameter space.	89
Figure 7.5:	95% confidence level exclusion limits on the cross section times branching fraction of $pp \rightarrow ee^* \rightarrow ee\gamma$	90
Figure A.1:	Expected 95% Exclusion limits for the standard analysis presented in this paper and the estimated change in the limits if events with objects combining to give the invariant mass of the Z are excluded.	93
Figure A.2:	Expected 95% Exclusion limits for the standard analysis presented in this paper and the estimated change in the limits if the pixel veto is included in the photon selection.	95

Figure A.3: Expected 95% Exclusion limits for the standard analysis presented in this paper and the estimated exclusion gained by including endcap photons.	97
Figure A.4: Invariant mass distribution for both invariant mass $e\gamma$ pairs. Signal is $M_{e^*} = 200, 400, 600 \text{ GeV}/c^2$	99
Figure A.5: Expected 95% Exclusion limits for the standard analysis presented in this paper and the estimated exclusion gained by using both invariant mass combinations.	100

LIST OF TABLES

Table 2.1:	Fermion properties. For anti-particles, all quantum numbers change sign (No <i>does not</i> become Yes).	10
Table 5.1:	Datasets used in this analysis.	53
Table 5.2:	MC samples and cross sections used in the signal analysis. For the signal the mass is as noted and Λ is chosen to be 4 TeV. Samples are generated with PYTHIA unless marked “MadGraph”	54
Table 5.3:	HLT’s used for this analysis.	55
Table 5.4:	Generator-level acceptances	56
Table 5.5:	Tight photon selection cuts used in the e^* analysis.	58
Table 5.6:	HEEP electron election	62
Table 5.7:	Data and MC background event selection results for $\int L = 36 \text{ pb}^{-1}$. In the MC determined backgrounds, the photon and electrons are required to match with $\Delta R < 0.1$ to generator level photons or electrons for rows “2 HEEP e ” and beyond.	64
Table 5.8:	Signal results and efficiencies scaled to $\int L = 36 \text{ pb}^{-1}$ for $\Lambda = 4 \text{ TeV}$	66
Table 5.9:	Loose selection cuts for denominator	71
Table 5.10:	Flipped selection cuts for denominator is the ‘OR’ of all the cuts	71
Table 5.11:	Loosened Photon Selection	74
Table 6.1:	Systematic errors included in limit setting and the size of the effect for $M_{e^*}=200 \text{ GeV}/c^2$. The total error given at the bottom is calculated by adding relative errors in the column in quadrature.	82
Table 7.1:	Expected backgrounds broken down by type after final one-sided mass cuts of 180, 350, and 500 GeV/c^2 respectively.	85
Table 7.2:	Passing data events and efficiencies for the full analysis. Λ is taken to be 4 TeV for the signal expectation column. Errors are reported as (stat.) \pm (syst.).	87
Table 7.3:	Total number of events produced and passing the final one-sided cut for various values of M_{e^*} and Λ	88
Table A.1:	Passing data events and efficiencies when excluding events with any set of objects reconstructing to the Z mass.	92
Table A.2:	Estimated changes in expected limits on the cross section and Λ if the events with any set of objects have an invariant mass near the Z mass are removed. A positive value indicates a gain of sensitivity.	92
Table A.3:	Passing data events and efficiencies when including the pixel veto in the photon selection.	94

Table A.4:	Estimated changes in expected limits on the cross section and Λ if the pixel veto criterion is used in the photon selection. A positive value indicates a gain of sensitivity.	94
Table A.5:	Estimated efficiency loss due to exclusion of EE region. Identical photon selection criteria (Table 5.5) are used for the endcap region.	96
Table A.6:	Passing data events and efficiencies for when including endcap photons.	96
Table A.7:	Estimated changes in expected limits on the cross section and Λ if endcap photons are included. A negative value indicates a loss of sensitivity.	97
Table A.8:	Passing data events and efficiencies for when using both mass combinations.	98
Table A.9:	Estimated changes in expected limits on cross section and Λ if both $e\gamma$ invariant masses are included and a symmetric, two-sided cut is imposed. A positive value indicates a gain of sensitivity.	99

ACKNOWLEDGEMENTS

First, I must thank the CMS and LHC collaborations that made this research possible. I also needed the support and teaching of the UCSD physics department, especially the high energy group. Of course, a huge thank you to my advisor, Jim Branson. Apart from sharing his extensive knowledge of physics and teaching me how to do good science, I am greatly indebted to him for allowing me to work remotely and build a life and family while pursuing my education. Every step of the way he encouraged me to keep going and just make it work. Jim also gathered a great group of people as postdocs, technical staff, and researchers to help along the way. Andre, Riccardo and Matteo - thanks for answering all the stupid questions, and doing so with a smile. Thanks also to Matteo for a great excuse to visit Siena and for my first Italian wedding experience. Marco, you made so much of my time at CERN unforgettable.

My time in San Diego would not have been the same without the friends I made here. I'll always remember studying at the zoo, my attempt to surf, and refusing to go to Sipz. Andrew, Sean, and Evan - you guys are awesome, and not just for bringing around your better halves, Emily, Eva, and Hollie. Sean, thank you also for being the world's best office mate, a great Christmas caroler (even in October while drinking barrel wine), and happy enough to defeat many of my bad moods. Thanks to mnorman for reading the thesis (the whole thing!), encouraging a life outside of physics, and knowing something about everything. I also made great friends in Geneva like mwl, Mariarosaria, and Dr. Ribnik. R1 wouldn't have been any fun without you all.

Most importantly, I would like to acknowledge my family. Mom and Dad, I wouldn't have made it anywhere near graduate school without you in my corner. Thanks for sticking with me every step of the way. Original Matt, thanks for being a great brother and friend. Kelly, you're the best. I hope I've been there for you even half as well as you have been there for me. Soon you'll be done too. Then there's my newer family. Matt, you're more than I could ever have wished for in a partner. You made my goals a reality. Jack - you won't remember this time in our lives, but it's been magical. I love you all very much.

VITA

- 2004 B. A. in Physics *magna cum laude*, Boston University, Boston
- 2008 M. S. in Physics, University of California, San Diego
- 2012 Ph. D. in Physics, University of California, San Diego

ABSTRACT OF THE DISSERTATION

**A search for excited electrons with the Compact Muon Solenoid
detector**

by

Elizabeth Jane Dusinberre Sudano

Doctor of Philosophy in Physics

University of California San Diego, 2012

Professor James Branson, Chair

A search for excited electrons using the CMS detector at the LHC with 36 pb^{-1} of proton-proton collision data recorded at $\sqrt{s} = 7 \text{ TeV}$ is presented. The search is performed for associated production of an electron and an excited electron followed by the decay of the excited electron to an electron and a photon for a final state of $ee\gamma$. No excess of events above the standard model expectation is observed. Interpreting the results in the context of production via novel four-fermion contact interactions and the subsequent decay via electroweak processes, upper limits on the production cross section are set. The exclusion region in the compositeness scale, Λ , and excited electron mass, M_{e^*} , parameter space is extended beyond previously established limits. For $\Lambda = 2 \text{ TeV}$, excited electron masses are excluded below $760 \text{ GeV}/c^2$ are excluded at the 95% confidence level. The cross sections for masses between 200 and $1500 \text{ GeV}/c^2$ are limited to be less than $0.21 - 0.16 \text{ pb}^{-1}$.

Chapter 1

Introduction

The pursuit of understanding of our world is something humans have engaged in since the first day they had some free time. We started out knowing precisely nothing and from that start have learned a startling amount. By the time American students have left high school, some of them have managed to absorb the idea that matter is made up of molecules, which are made up of atoms, which are made up of protons, neutrons and electrons. A few may also know that the photon is also involved in this picture somehow. It may be a bit startling for them to learn that beyond this neat layer of protons, neutrons, and electrons that make up their whole universe lies a much more complex world of particles and forces that scientists are still learning about to this day. The working theory is that eventually you reach the level of fundamental particles that have no further substructure or compositeness. This thesis will describe a small corner of the current research ongoing in the effort to understand the physics of everything.

Chapter 2 will introduce the current most successful theory of particle physics, the Standard Model, and the extension of it that produces excited electrons. In Chapter 3, the accelerator and machine used to perform this research are described. Chapter 4 gives an explanation of how we take the information from our detector and use it to search for new physics. In Chapter 5 the details of the excited electron search are explained, and in Chapter 6 some major sources of systematic uncertainty are detailed. Finally, in Chapter 7, we present the results of this search and set limits in the context of the theory described in Chapter 2.

Chapter 2

The Standard Model of Particle Physics and Beyond

Particle physics is the study of the fundamental constituents of matter and their interactions. Almost all collider physics data to date can be described by the Standard Model. It is one of the most accurate and well-tested scientific models in existence, and describes 3 of the 4 fundamental forces (we cannot yet incorporate gravity) and the particles that interact via these forces. The first section of this chapter will introduce the particles and interactions of the Standard Model. In later sections the parts of the Standard Model most relevant to this analysis will be examined in more mathematical detail.

Though the Standard Model can be used to quite accurately describe the modern universe, it does not describe phenomena such as gravity, the quantization of charge, dark matter, or dark energy, among other things. One outstanding question is the origin of the three generations of leptons and quarks. One possibility is an extension of the Standard Model where the leptons are not point particles, but are composite particles. After discussing the Standard Model in the following sections, we will take a closer look at this theory and how to test it.

2.1 An Overview of Particles and Forces

There are many textbooks that do a much better and more thorough job of covering the current state of our knowledge of particle physics, such as [1] and [2]. Here we present an abbreviated overview; skipping the experimental side of the story to focus on giving the reader the vocabulary and orientation necessary to read the rest of this thesis.

Let us begin by extending an exercise from a middle school science class where we start with a block of matter and zoom in. We go from matter to molecules to atoms to electrons and nuclei in search of what our universe is made of at a fundamental level. The nucleus is where, in most science classes, the zooming stops. In some sense this is a good breaking point because beyond this, instead of zooming in and finding fewer particles than we had at the previous level, we will complicate matters.

The force binding the electrons to the nuclei is quite familiar from everyday life: electromagnetism. This force has infinite range because its mediator, the photon (γ), is massless. All particles with non-zero electric charge interact electromagnetically.

The interested student may have noticed that their teacher invoked the “opposites attract” nature of the electromagnetic force to explain how electrons are bound to nuclei, but glossed over an explanation of all those protons bound even more tightly in the nucleus. To explain this we must introduce new particles, a new force, and its mediator. Forces can be thought of as exchanges of force-carrying particles, and each fundamental force has one or more of these mediators. For the electromagnetic force this is the photon. In the nucleus the dominant force is the strong force which is mediated by the gluon (G). Gluons do not interact directly with protons and neutrons, but with their constituents, quarks. Now we have reached what modern particle physics considers to be elementary particles. Matter is made up of electrons and quarks and held together by two forces, the electromagnetic and strong forces, mediated by photons and gluons.

A proton is one down-type quark (d) with charge $-\frac{1}{3}$ and two up-type quarks (u) with charge $\frac{2}{3}$ to give a net charge of $+1$. A neutron has two d quarks

and one u quark for a total charge of 0. The strong force binds the quarks into the proton and also binds the nucleons together to form the nucleus. Recalling that nuclei are bound states of many neutrons and positively charged protons, we can infer that the attractive nature of the strong force between the quarks is enough to overcome the electromagnetic repulsion that exists between the protons. In reality, the situation inside a nucleus is much more complicated due to the nature of the strong force, but we will discuss that a bit later.

With the introduction of two new particles and a new force we have painted a much more accurate, but still simplified, picture of matter. There is still one relatively common process that we cannot explain with the tools we have: beta decay. This is the process by which a neutron decays to a proton and emits an electron and an anti-neutrino ($\bar{\nu}_e$) in the process. A neutrino is a neutral, nearly massless particle that only interacts via our third fundamental interaction, the weak interaction. If we want to write this process in terms of our elementary particles we can say $udd \rightarrow udu + e^- + \bar{\nu}_e$, where the arrow stands in for the mediator of the weak force, the W^+ boson. The Z boson is the uncharged mediator of the weak force. The weak force, as one would guess, is much weaker in strength than the strong and electromagnetic forces. Its mediators are quite massive (80 and 90 GeV/c^2), so it operates only over a short distance.

In the description of beta decay, two new bits of notation have been introduced. First, the bar over the ν denotes the ‘anti’ part of anti-neutrino. All matter particles have a corresponding antiparticle with the same mass and spin, but all other quantum numbers (charge, lepton number, etc) flipped. The e subscript is to denote that the antineutrino in this process is from the electron generation of our particle scheme. There are three “copies”, called generations, of the e , ν_e , u , d particles. Similarly to the periodic table where elements with the same valence electron numbers have different masses but behave in some similar ways, the muon and tau generations are more massive versions of the electron generation. In the last couple decades, neutrinos have been shown to have non-zero masses with a hierarchy less straight-forward than $\nu_e < \nu_\mu < \nu_\tau$, but for our purposes we consider them to have negligible mass. We have now added four more quarks, charm (c),

strange (s), top (t), and bottom (b), and four more leptons, the muon (μ), tau (τ), muon neutrino (ν_μ), and tau neutrino (ν_τ).

To complete the “particle zoo” (Figure 2.1) we are only missing the Higgs boson. The Higgs is predicted by the Standard Model, but not yet observed. It gives mass to matter. This will be discussed in more detail in the following section.

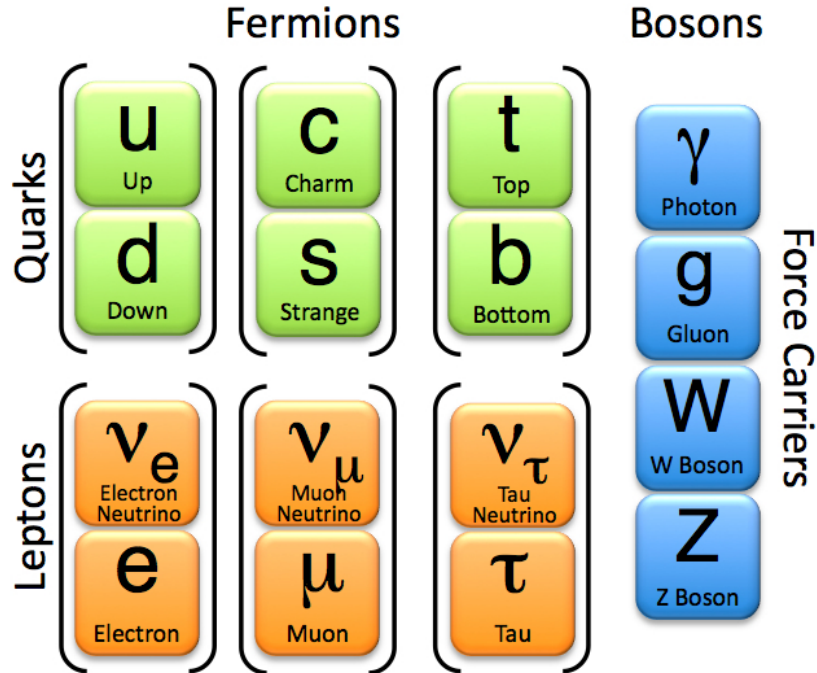

Figure 2.1: A table of the elementary particles.

The particles in Figure 2.1 are grouped in a couple of meaningful ways. One designation is based on the spin of particles. Bosons have integer spins and obey Bose statistics. Fermions have half-integer intrinsic spin and obey Fermi statistics. The bosons are the mediators of the forces. All matter is fermionic and can be further divided into leptons and quarks. This denotes whether the particle interacts strongly; quarks interact strongly and leptons do not. This can also be phrased by saying that quarks have color charge and leptons do not, so leptons do not *couple* to gluons. Gluons can also self-interact. Particles that have non-zero electric charge couple to photons. Again, the weak interaction is a little more subtle. The quantum number associated with it is weak isospin. Furthermore, the

weak interaction only couples to left-handed particles. These are particles which transform under the left-handed Poincaré group. All the left-handed fermions couple to the W and Z bosons, and the W and Z can also interact with each other.

One convenient way to depict which particles interact is using Feynman diagrams. Figure 2.2 shows all of the allowed interactions in the Standard Model (excluding Higgs interactions).

Let us review. We have three fundamental forces: electromagnetic, strong, and weak. They are mediated by bosons: the photon for electromagnetism, the gluon for the strong force, and the W and Z bosons for the weak force. The relative strengths of these forces can be described by their coupling constants, α : α_s : and $\alpha_w \approx \frac{1}{130}, .1, 10^{-6}$. Charged particles (including the W bosons) interact via the electromagnetic force, colored particles (including gluons) via the strong force, and left-handed particles via the weak force.

Matter is made of fermions. The leptons may exist unbound in nature, although the heavier leptons can decay to other particles. Quarks, however, can only be found in bound states without net color called hadrons. There are two types of hadrons. States of three bound quarks or antiquarks are called baryons. The proton (uud) and neutron (udd) are baryons. Mesons are bound quark-antiquark pairs. The lightest meson is the π^0 ($\frac{u\bar{u}+d\bar{d}}{\sqrt{2}}$). The lightest hadron is the proton (the neutron is just a touch heavier).

Including hadrons, there are very many observed particles. Most of these are unstable and not directly observable. For the purposes of collider physics only photons, electrons, muons, and neutrinos are stable. Here stable means that we detect these particles directly rather than looking for another set of particles they might decay into. Muons, for example, do decay, but their lifetime is long enough that they are nearly always detected by CMS before this happens, so we call them stable. Quarks and gluons are detected via their hadronic byproducts. Detection of all these particles will be discussed in the next chapter.

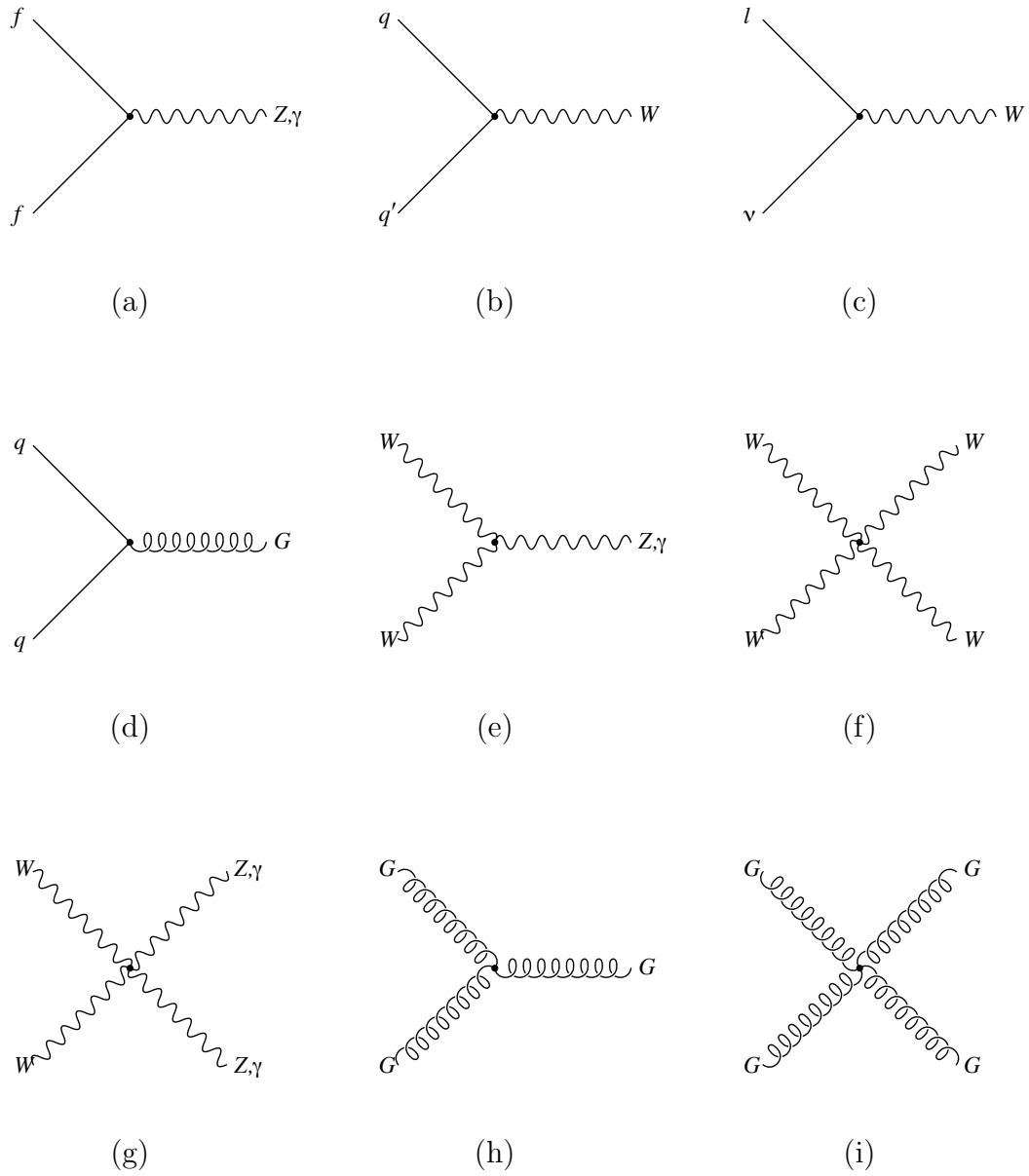

Figure 2.2: The allowed interactions of the Standard Model. Note: in diagram (a) the “ f ” does not include the neutrinos for the interaction with the photon (γ).

2.2 The Standard Model

All of the particles and interactions of the previous section can be described mathematically using quantum field theory. This mathematical representation allows us to see the relationships between the various pieces of the model and make testable predictions such as the rates of various processes. Without this framework, making sense of the wealth of particle physics data collected over the years would be impossible. Writing down a mathematical description also illuminates some of the shortcomings of the theory. What follows is a quick tour of the Standard Model focusing on its successes and features and then a bit of motivation for the search for excited electrons.

The Standard Model is a quantum field theory with three gauge symmetries, $SU(3) \times SU(2) \times U(1)$. A gauge symmetry means that the theory is invariant under a *group* of transformations. $SU(3)$, $SU(2)$, and $U(1)$ are the groups under which our theory is invariant. Each unbroken symmetry has an associated conserved quantity. The $SU(3)$ symmetry gives rise to the conservation of color charge and describes the strong interaction. The $SU(2)$ and $U(1)$ parts of the model are the weak and electromagnetic interactions. A major theoretical success of the Standard Model is the unification of the electromagnetic and weak forces. Above a certain energy (about 200 GeV) these two forces can be understood as one force, the electroweak force. The conserved quantities are weak isospin, T_3 , and weak hypercharge, Y . The familiar electric charge, $Q = T_3 + \frac{Y}{2}$, is the remaining conserved quantity.

The first theory to be described using this type of formalism was quantum electrodynamics (QED) which described the interactions of charged particles (electrons) and photons. This is a $U(1)$ theory whose Lagrangian is:

$$\mathcal{L} = \bar{\psi}(i\gamma^\mu D_\mu - m)\psi \quad (2.1)$$

where D_μ is the covariant derivative, $\partial_\mu - ieA_\mu$, necessitated by the gauge invariance requirement. Inputting the covariant derivative we can more clearly identify some of the players in this theory.

$$\mathcal{L} = i\bar{\psi}\gamma^\mu\partial_\mu\psi - m\bar{\psi}\psi - e\bar{\psi}\gamma^\mu A^\mu\psi \quad (2.2)$$

The first term is the kinetic term for the ψ fields which are the charged particles. The second term is their mass term. Next is the interaction of the charged particles with the field A^μ . γ^μ are the Dirac matrices and e the electric charge. There is no allowed mass term for the A^μ field. This fits with our understanding that the electromagnetic force is mediated by the massless photon.

The full picture is not so simple. In the 1960s the work of Abdus Salam, Sheldon Glashow and Steven Weinberg unified the electromagnetic and weak forces in an $SU(2) \times U(1)$ theory[3, 4, 5]. When the symmetry is unbroken, there are three massless W bosons which act on particles with weak isospin (under the $SU(2)$) and a massless B^0 boson interacting with particles with weak hypercharge ($U(1)$). At low energies (where we observe physics) this symmetry is broken giving us the two separate forces and the observed two massive W bosons and massive Z^0 that interact with particles with weak isospin and the massless photon which interacts with particles carrying non-zero electric charge. All left-handed fermions have weak isospin and interact with the W and Z bosons. Table 2.1 shows the Standard Model fermions and their properties.

An interesting feature of the weak interaction is its left-handed nature. This means that only particles whose spin is anti-aligned with its momentum couple to the W and Z bosons. The handedness of the theory means that the parity symmetry is violated by the weak interaction. The charge conjugation symmetry is also violated by the weak interaction, but these symmetries are both respected by the other interactions.

Quantum chromodynamics (QCD) describes the strong interaction, and is different from the electroweak force in that the theory is “asymptotically free” [6, 7]. When quarks are arbitrarily close together (at high energies) their interactions are weak, but at larger distances the strength of the interaction increases. This means they cannot exist unbound in nature. When they are produced at CMS they immediately hadronize; they combine with other quarks or anti-quarks to produce mesons and baryons. This is a messy procedure, and often there are large multiplicities of particles created. Quarks and gluons carry color charge, but all observed matter is colorless. So, a meson must have, for example, a *red* and an

Table 2.1: Fermion properties. For anti-particles, all quantum numbers change sign (No *does not* become Yes).

Particle	Spin	Q	Y	T_3	Color
e_L, μ_L, τ_L	$\frac{1}{2}$	-1	-1	$-\frac{1}{2}$	No
ν_e, ν_μ, ν_τ	$\frac{1}{2}$	0	-1	$+\frac{1}{2}$	No
u_L, c_L, t_L	$\frac{1}{2}$	$+\frac{2}{3}$	$+\frac{1}{3}$	$+\frac{1}{2}$	Yes
d_L, s_L, b_L	$\frac{1}{2}$	$-\frac{1}{3}$	$+\frac{1}{3}$	$-\frac{1}{2}$	Yes
e_R, μ_R, τ_R	$+\frac{1}{2}$	-1	-2	0	No
u_R, c_R, t_R	$\frac{1}{2}$	$+\frac{2}{3}$	$+\frac{4}{3}$	0	Yes
d_R, s_R, b_R	$\frac{1}{2}$	$-\frac{1}{3}$	$-\frac{2}{3}$	0	Yes

anti-red quark for its constituents, and a baryon must have one each of *red*, *green*, and *blue* or *anti-red*, *anti-green* and *anti-blue*. There are eight gluons carrying mismatched color/anti-color charges such as *red/anti-green*. At particle physics experiments the different gluons are completely indistinguishable from each other, and also from most quarks. The exceptions are the heavy top and bottom quarks which actually decay before they hadronize and can be identified with some precision from the rest of the quarks and gluons produced.

As of the writing of this thesis, the final piece of the Standard Model, the Higgs boson, still only exists in theory [8, 9, 10]. This uncharged boson would be the Standard Model's only scalar and is restricted, experimentally, to have a mass of at least 114 GeV/ c^2 and less than 145 GeV/ c^2 , between 288 and 296 GeV/ c^2 or above 466 GeV/ c^2 [11, 12]. Though it has not been observed, it plays a key role in the Standard Model; the Higgs mechanism is what breaks the electroweak symmetry and gives the W and Z bosons mass. The ratio of the W mass to the Z mass is well-predicted by this part of the theory. Fermions can also acquire mass through this mechanism; the strength of the coupling determines the mass of the particle. The observation of the Higgs boson (or ruling it out) is one of the major goals of the LHC experiments.

For completeness, 2.3-2.7 give the Standard Model Lagrangian.

$$\mathcal{L} = -\frac{1}{4}\mathbf{W}_{\mu\nu} \cdot \mathbf{W}^{\mu\nu} - \frac{1}{4}B_{\mu\nu} \cdot B^{\mu\nu} \quad (2.3)$$

$$+ \bar{L}\gamma^\mu \left(i\partial_\mu - g\frac{1}{2}\boldsymbol{\tau} \cdot \mathbf{W}_\mu - g'\frac{Y}{2}B_\mu \right) L + \bar{R}\gamma^\mu \left(i\partial_\mu - g'\frac{Y}{2}B_\mu \right) R \quad (2.4)$$

$$- g_s(\bar{q}\gamma^\mu T_a q)G_\mu^a - \frac{1}{4}G_{\mu\nu}^a G_a^{\mu\nu} \quad (2.5)$$

$$+ \left| \left(i\partial_\mu - g\frac{1}{2}\boldsymbol{\tau} \cdot \mathbf{W}_\mu - g'\frac{Y}{2}B_\mu \right) \phi \right|^2 - V(\phi) \quad (2.6)$$

$$- (G_1\bar{L}\phi R + G_2\bar{L}\phi_c R + h.c.) \quad (2.7)$$

This describes all of the interactions of observed particles and the Higgs boson. First (2.3) are the kinetic terms for the W , Z , and photon, the force carriers of electroweak theory. Next, (2.4) shows the terms relating to the kinetic terms for the leptons and quarks (L represents the left-handed fermions and R the right-handed fermions) as well as their interactions via electroweak theory. (2.5) are the QCD interactions of quarks and gluons and the gluon self-interaction terms. The interactions between the electroweak force carriers and the Higgs are shown in (2.6) and the lepton and quark interactions are in (2.7) [2].

Though the Standard Model is extremely successful in describing much of the observed world, it is widely believed to be an effective theory that only works below energies of about the TeV scale [13]. This is the same basic idea as the electromagnetic and weak interactions, which are unified above a few hundred GeV. Below that energy the electromagnetic and weak interactions we observe are described by effective theories. Many different possible extensions are being investigated by theorists. Two such theories are supersymmetry where each particle has an as yet unobserved massive partner of the opposite spin type (i.e. bosons have a fermion super-partner), and string theory where all matter is made of vibrating “strings” of energy. A simple extension of the Standard Model is substructure in the lepton and quark sectors.

2.3 Excited Electrons

One of the many as yet unexplained features of the Standard Model is the mass hierarchy observed in the the lepton and quark sectors; why are there three copies of the electron with one heavier than the next? One possibility is that quarks and leptons are composite particles with substructure that gives rise to these masses. The quarks and leptons could be composite states of preons (point-like particles); either one fermion and one gauge boson or three fermions[14]. The parameter of interest in this analysis is Λ , the scale of a contact interaction through which these excited states could be produced. This substructure could also explain the mixing of the quark and lepton sectors and make fermion masses and weak mixing angles calculable, thereby eliminating a number of parameters in the current model.

If the excited states exist, they can be produced singly due to radiative transitions between standard and excited fermions (Equation 2.8) [15, 16] or via novel contact interactions. They can also be produced pairwise due to these contact interactions (Equation. 2.9)[16]. Figures 2.3 and 2.4 show the hypothesized interactions.

$$L_{trans} = \frac{1}{2\Lambda} \bar{f}_R^* \sigma^{\mu\nu} \left[g_s f_s \frac{\lambda^a}{2} G_{\mu\nu}^a + g f \frac{\tau}{2} \cdot W_{\mu\nu} + g' f' \frac{Y}{2} B_{\mu\nu} \right] f_L + h.c. \quad (2.8)$$

$$L_{contact} = \frac{1}{2} \frac{g_*^2}{\Lambda^2} j^\mu j_\mu ; \quad j_\mu = \eta_L \bar{f}_L \gamma_\mu f_L + \eta'_L \bar{f}_L^* \gamma_\mu f_L^* + \eta''_L \bar{f}_L^* \gamma_\mu f_L + h.c. + (L \rightarrow R) \quad (2.9)$$

The cross section of the process scales with the ratio $\left[\frac{m^*}{\Lambda}\right]^4$ where m^* is the excited electron (e^*) mass, as seen in Equation 2.10. This search will be for single excited electrons produced in conjunction with a standard electron that then decays to an electron and a photon. Limits will be placed on the maximum allowable cross section of the process and the parameter Λ in the context of this model.

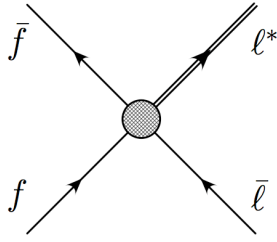

Figure 2.3: Excited electrons can be produced singly via novel contact interactions.

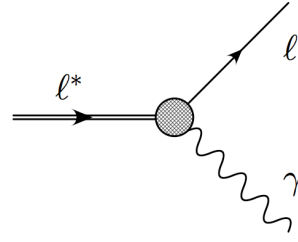

Figure 2.4: Excited electrons can also be produced (or decay) via interactions with ordinary gauge bosons (here the photon).

$$\hat{\sigma}(q\bar{q} \rightarrow l\bar{l}^*, l^*\bar{l}) = \frac{\pi}{6\hat{s}} \left[\frac{\hat{s}}{\Lambda^2} \right]^2 \left[1 + \frac{v}{3} \right] \left[1 - \frac{m^{*2}}{\hat{s}} \right]^2 \left[1 + \frac{m^{*2}}{\hat{s}} \right] ; \quad v = \frac{\hat{s} - m^{*2}}{\hat{s} + m^{*2}} \quad (2.10)$$

The final state is $ee\gamma$, which has a very low expected background. All three of these final state particles have high transverse energy (E_T). One of the invariant mass combinations of the photon and an electron will reconstruct to the excited electron mass. Including other final states such as the decays $e^* \rightarrow eW, eZ$ would increase the yield (Figure 2.5), but also have less clean final states. Previous searches were completed at LEP [17, 18, 19, 20, 21], HERA [22, 23], and the Tevatron[24, 25]. In early running the backgrounds are so low that a simple counting experiment suffices to set the best limits. In future studies it may be advantageous to actually search for the peak in the $e\text{-}\gamma$ mass distribution from the decay of the e^* .

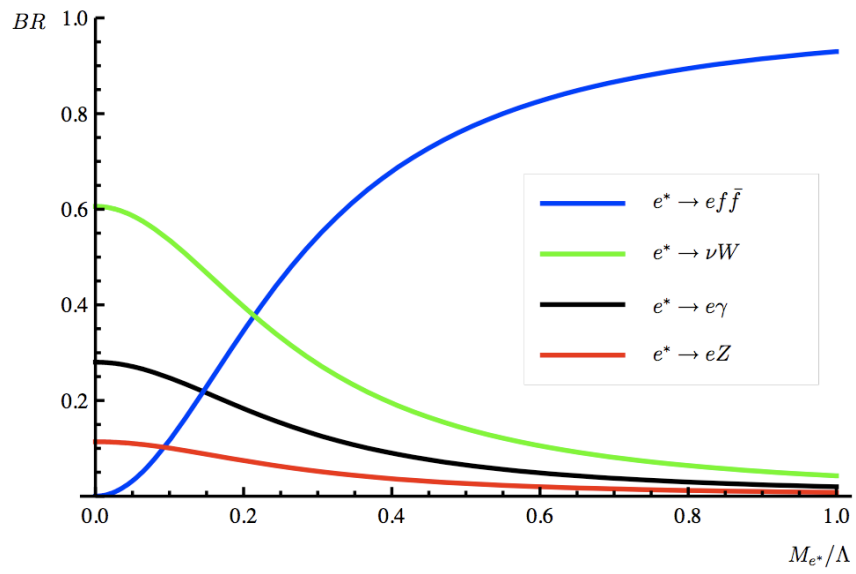

Figure 2.5: Plot of branching fractions to various final states as a function of M/Λ

Chapter 3

The Large Hadron Collider and the Compact Muon Solenoid

The Large Hadron Collider (LHC) is the highest energy particle accelerator and collider on the planet at the time of the writing of this thesis. It is designed to collide bunches of protons (1.1×10^{11} protons per bunch) at a center of mass energy of 14 TeV once every 25 nanoseconds. The design luminosity is $10^{34} \text{ cm}^{-2} \text{ s}^{-1}$; with the eventual aim being to provide 100 times the integrated luminosity of past experiments. The scientific goal of this machine is to extend our knowledge of physics into this new energy regime, and hopefully discover what laws of physics exist beyond the Standard Model. After nearly 20 years of design and research and 10 years of construction, it is finally providing a first glimpse at the data the physics community has so eagerly awaited [26].

The LHC program was preceded by many other experiments that shaped its focus and contributed years of knowledge and experience for its engineers and scientists to draw upon in designing, building, and operating such a complex and delicate machine. In 1983 the W and Z bosons were discovered by the UA1 and UA2 experiments at CERN [27, 28, 29, 30]. This was followed by the observation of the top quark at the Tevatron (the previous highest energy collider) in 1995 [31, 32]. These particles were predicted to exist by the Standard Model. The only remaining missing piece is the Higgs boson. This will be one of the many signatures searched for at the LHC.

3.1 The Large Hadron Collider

The LHC resides in an existing 27 km tunnel near the outskirts of Geneva, Switzerland that previously housed the Large Electron-Positron Collider (LEP). In 2000 the LEP program was ended to make way for the construction of the LHC. The tunnel lies between 45 and 170 m underground below parts of both Switzerland and France. There are four experimental caverns along the path of this tunnel where the proton beams are collided; two house “multipurpose” detectors for proton-proton collisions: A Toroidal LHC Apparatus (ATLAS) [33] at Point 1 and the Compact Muon Solenoid (CMS) at Point 5 (P5). Large Hadron Collider beauty (LHCb) at Point 2 is a b-physics experiment designed to measure CP violation parameters with high precision and the interactions of particles with a b quark as a constituent[34]. A Large Ion Collider Experiment (ALICE) at Point 8 is a general-purpose detector built to study the lead-lead ion collisions planned at the LHC[35]. It focuses on the studying the strong interaction and quark-gluon plasmas at the high temperatures and densities yielded by the lead ion collisions. Also at P5 is the Total Cross Section, Elastic Scattering and Diffraction Dissociation (TOTEM) experiment whose goal is to measure the proton-proton cross-section in a luminosity independent way and to study diffractive physics at the LHC[36]. The Large Hadron Collider forward (LHCf) experiment dedicated to the study of very forward neutral particles in order to investigate the origin of extremely high-energy cosmic rays is also located at P1[37].

The LHC consists of eight straight sections where the experimental caverns and utilities such as collimators and RF cavities are housed and eight arced sections. 1232 dipole magnets are used to steer the beam around the arced sections, and must operate at a field strength of 8.33 T to bend the proton beams in a tight enough curve to use the LEP tunnel. In order to reach such a high field strength, the magnets must be cooled to 1.9 K using superfluid liquid helium. An additional 392 quadrupole magnets are used to focus the beams. Various other specialized magnets are required to deal with the couplings of the fields from the experiments (CMS’s solenoid, for example), the flux of secondary particles emerging from collision points, and for other necessary beam steering operations.

The bare protons are produced by stripping hydrogen atoms of their electrons. Then the protons undergo their first acceleration up to 50 MeV at the LINAC2. Next come accelerations in the Proton Synchrotron Booster to 1.4 GeV, the Proton Synchrotron to 25 GeV, and the Super Proton Synchrotron. Finally, they are injected into the LHC at 450 GeV. The proton beams are further accelerated by the LHC itself using a 400 MHz super conducting cavity system to the desired energy in about 20 minutes.

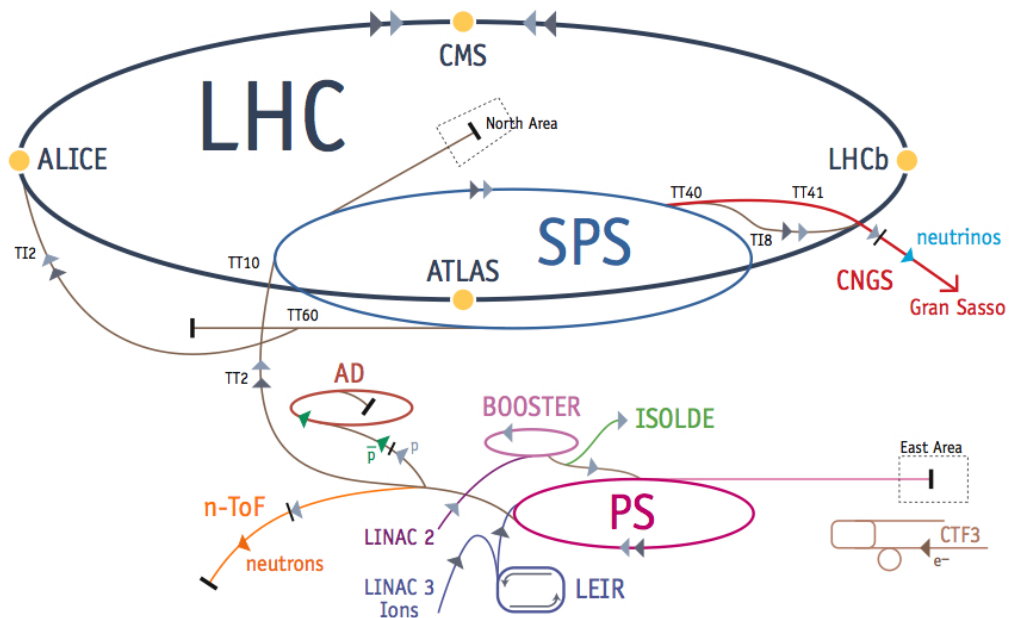

Figure 3.1: The CERN accelerator complex [38]

After this accelerator phase, the LHC changes modes and becomes a collider. At the four interaction points the beams are crossed and the protons collide. The quarks and gluons making up the protons interact, and, at various rates, interesting physics is sprayed into the detectors to be collected and analyzed by physicists.

3.2 The Compact Muon Solenoid

This thesis will focus on data from collisions recorded at the CMS detector. The source for the information in this chapter is the CMS Technical Design Report [39, 40] unless otherwise noted. CMS is one of the two large, multipurpose detectors where the LHC collides the proton (and later lead ion) beams and the products of the collisions are recorded. The detector is located at P5 about 100 m underground in Cessy, France. The detector consists of a solenoid and four main sub-detector systems: the silicon trackers, the electromagnetic calorimeter, hadronic calorimeter, and the muon system. The guiding principles of CMS's design are as follows:

The trackers must be able to give a good measurement of the momenta of charged particles as they travel through the tracking volume along helices in the strong magnetic field provided by the solenoid.

The electromagnetic calorimeter system should provide good energy resolution for electron and photons, good diphoton and dielectron mass resolution (about 1% at 100 GeV), provide coverage over a large geometrical area, and allow for π^0 rejection and efficient isolation of electrons and photons at high luminosity.

The hadronic calorimeter system should be highly hermetic with fine segmentation in $\theta - \phi$ to ensure good resolution for missing transverse energy and dijet mass measurements.

The muon system must allow for muon identification and provide good dimuon mass resolution (about 1% at 100 GeV) over large angular and momentum ranges. Additionally it should provide muon charge ID for muons up to 1 TeV in momentum[41].

These requirements must be met in an extremely harsh environment. The energies of the beams are up to 7 times those found at the Tevatron and the design luminosity is up to a factor of 100 larger. With the proton-proton cross-section estimated to be 100 mb at the 14 TeV center of mass energy, this will

result in 20 inelastic collisions at each bunch crossing. The collisions that occur simultaneously with the interesting collision are known as pile-up events. This means that about 1000 charged particles will pass through CMS every 25 ns. In spite of these challenges, these design goals are being met.

In the following sections each of these subsystems will be discussed in more detail. First we discuss CMS in general, the magnet, and the layout of the subsystems. Then we will cover the tracking systems, followed by the calorimeters, and finally the muon system.

3.2.1 The CMS Coordinate System

CMS is approximately cylindrical, weighs 12,500 tons, and is 21.6 m long with a diameter of 14.6 m. The very center of CMS is the nominal interaction point; this is where the beams of protons will collide and is the origin of the CMS coordinate system. The coordinate system is right-handed with the y axis pointing up, the x axis pointing in towards the center of the LHC and the z axis being parallel to the anti-clockwise beam direction. Two other coordinates will be frequently used in this analysis, ϕ and η . The azimuthal angle ϕ is defined in the $x - y$ plane with the value 0 being along the x axis and $\pi/2$ along the y axis. The coordinate η is the pseudorapidity and is defined in terms of θ , the polar angle with respect to the z direction,

$$\eta = -\ln[\tan(\theta/2)]. \quad (3.1)$$

Pseudorapidity is a very useful quantity in particle physics because particle production is approximately constant in this variable. The physics in this analysis will be confined to the $|\eta|$ range 0-2.5.

3.2.2 The Layout of CMS

The layout of a particle detector like CMS is chosen such that one can measure as accurately as possible all of the interesting properties of the particles coming from the interaction point. As discussed in the previous chapter, different particles interact with matter differently, and this can be exploited to obtain

our measurements. The innermost detectors are the trackers, which are used to measure the momentum of charged particles. Next are the electromagnetic and hadronic calorimeters, which absorb and measure the energy of photons and electrons and hadrons. All of these detectors are situated inside of CMS's solenoid. The solenoid is 12.5 m long and has a bore of 6.2 m. The design field strength is 4 Tesla, but CMS operates with a 3.8 T field. The magnet is superconducting and is operated at 4.6 K. To return the field there exists a 10,000 ton yoke made of iron situated outside the magnet. It is interleaved with the muon system that also resides outside the solenoid.

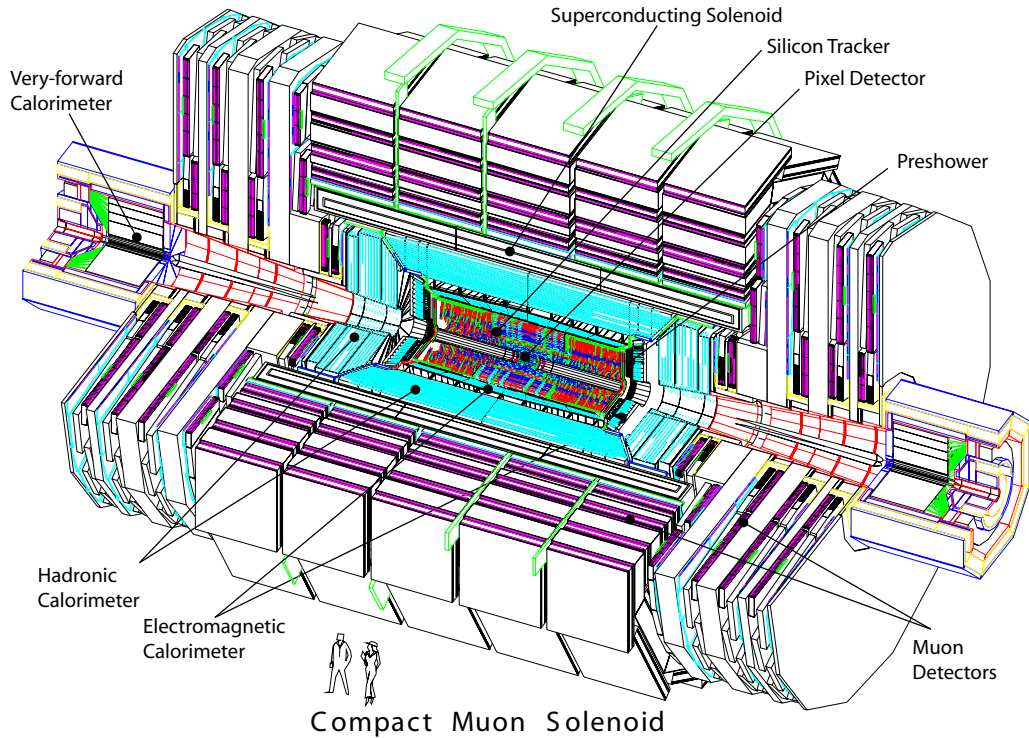

Figure 3.2: The Compact Muon Solenoid [42]

This ordering is governed by the nature of the measurements being made. Every time we measure a particle property, some information is lost. The least destructive measurements are made by the tracking system. Charged particles traveling through the material in the tracking volume interact and deposit some fraction of their energy. Any energy deposited is not available for absorption by

the calorimeters for their measurement of the particle's energy. The goal is to have a tracker that interacts with the charged particles to give us good information about a particle's momentum and point of origin (vertex) without having so much material that the energy measurements made by the calorimeters are useless.

The electromagnetic calorimeter is made of a material that has a short radiation length so that electromagnetically interacting particles will deposit the vast majority of their energy, but a long interaction length for strongly interacting particles. Ideally, the strongly interacting particles, the hadrons, should traverse both the tracker and then electromagnetic calorimeter without much interaction (except for charged tracks leaving "hits" in the tracker) and then be wholly absorbed by the hadronic calorimeter.

The muon chambers are placed outside of the tracker, calorimeters, and solenoid because of the weakly interacting nature of muons. They will pass right through all the material and leave "hits" in the muon chambers before sailing out of the detector. Neutrinos are both weakly interacting and have no electric charge. We must infer their presence using conservation of energy. For events with no neutrinos or exotic physics the sum of all the energy in the detector will give 0 (if you measure everything perfectly). A large amount of "missing energy" indicates that something exited your detector without being detected - a neutrino.

3.3 The Tracking System

The innermost detector system is the silicon tracking system. The goal of the silicon tracker is to allow for the measurement of the momenta of charged particles passing through the tracking volume and also to reconstruct so-called secondary vertices. These vertices are where particles with lifetimes of a few ps travel some distance from the collision point before decaying and their products are detected emerging from a vertex displaced from the interaction point. This purpose is especially important for the studies of particles with a bottom quark as a constituent, and τ s.

The tracker is divided into two main parts. The finest grain detector, the

pixel detector, is found closest to the interaction point and is surrounded by a larger but somewhat less granular silicon strip tracking detector. Both of these detectors are layered silicon detectors. The pixel detector is three layers in the radial range of 4.4 to 10.2 cm from the origin of the detector, and the strip tracker has 10 layers in the barrel and fills the region between 20 and 116 cm. Some of the layers are double-sided to provide additional information about the third coordinate (z in the barrel and r in the disks). The spacial resolution provided by the pixel detector is about $10 \mu\text{m}$ in (r, ϕ) and about $20 \mu\text{m}$ in (r, z) . The strip tracker's resolution ranges between $23 \mu\text{m}$ and $53 \mu\text{m}$ in (r, ϕ) and between $230 \mu\text{m}$ and $530 \mu\text{m}$ in (r, z) . The resolution requirements are loosened in the outer regions due to the lower expected occupancy at greater distance from the interaction point. The trackers both have endcap disks; two for the pixel detector and 12 for the strip tracker covering up to an η of about 2.5 for each detector. The layout of the tracker is shown in 3.3. It is designed so that most particles traversing the full tracking volume must cross at least 9 layers, 4 of which will be double sided. The tracker must provide accurate reconstruction of the momenta of charged particles down to an energy of about 1 GeV out to an $|\eta|$ of 2.4.

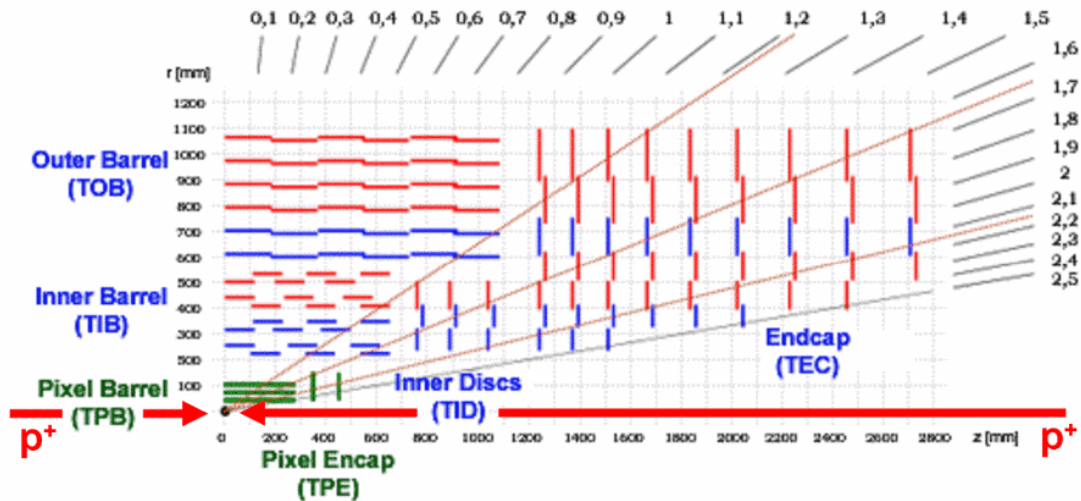

Figure 3.3: The layout of a quarter of the tracker [43]. The green shows the pixel detector and the red and blue the silicon tracker layers.

Due to the small time between bunch crossings, the detectors must be

fast, and the high flux of particles necessitates both a high granularity to keep occupancy rates reasonable and superior radiation hardness. The pixel detector's inner layer is only expected to function for 2 years in the extreme environment near the interaction point, and therefore the detector has been designed to allow access as often as every year. Further complicating matters and adding to the tracker material budget, the pixel detector must be cooled for operation at -10°C to reduce the effects of radiation damage.

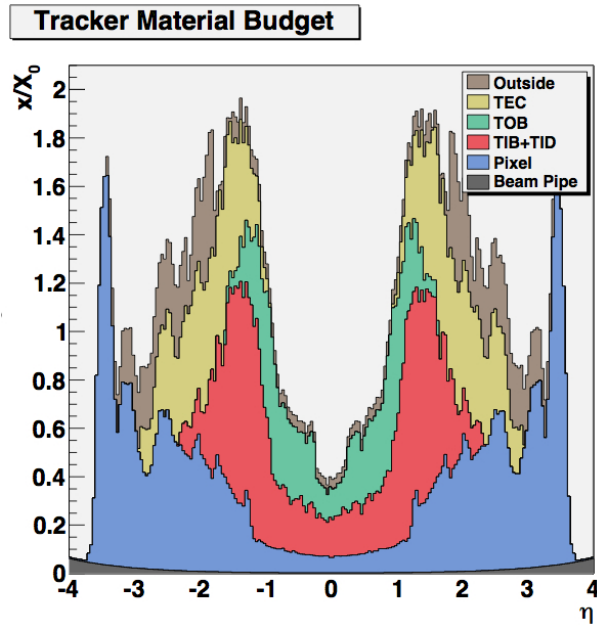

Figure 3.4: The amount of material making up the tracker as a function of η [44]

As previously mentioned, this fast, granular, radiation hard detector comes at a physics cost: the material in the tracker is shown in Figure 3.4. The more material there is, the harder it becomes to make precision measurements of photon and electron energy and position. The amount of material making up the tracker is about $0.5 X_0$ at $\eta = 0$, peaks at $1.8 X_0$ around $\eta = 1.5$ and then falls off somewhat. A photon or electron traversing one radiation length (X_0) will, on average, interact and deposit all but $1/e$ of its energy.

3.4 The Electromagnetic Calorimeter

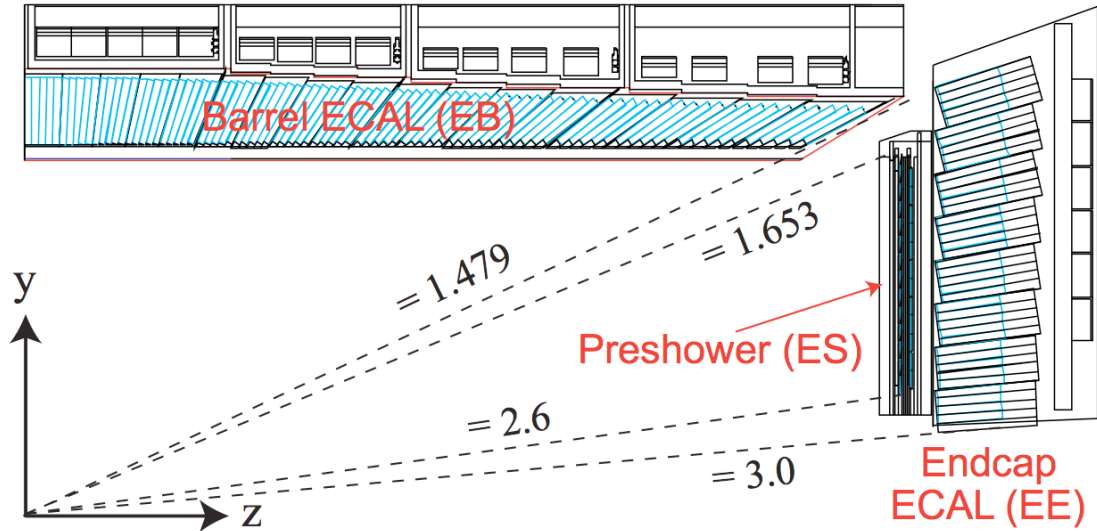

Figure 3.5: A $r - z$ depiction of a quarter of the CMS ECAL.

The CMS Electromagnetic Calorimeter (ECAL) is a detector designed to measure the energy of photons and electrons produced in collisions at CMS. There are three main sections of the detector; a cylindrical barrel region and two endcap disks. It is composed of approximately 74 000 lead tungstate (PbWO_4) crystals. These crystals are chosen for their radiation hardness, fast scintillation, short radiation length (0.89 cm), small Molière radius (2.2cm) and long interaction length (20.27 cm). They are optically clear but denser than iron, and 80% of the scintillation light produced is emitted within 25 ns (the nominal bunch spacing of CMS). The radiation length is the distance an electron or photon travels through a material while depositing all but $\frac{1}{e}$ of its energy. An interaction length is the distance typical of a hadronic interaction in a material. The Molière radius characterizes the lateral size of the electromagnetic shower. To measure the energy of electrons and photons we want a short radiation length so that a large fraction of the object's energy will be deposited in the compact depth of the calorimeter; the Molière radius dictates the width and height of the crystals and allows for a highly granular calorimeter. Finer granularity allows better precision in the position de-

termination which is important for reconstructing narrow resonances. The long interaction length means the hadronically interacting particles will sail through the ECAL without depositing much of their energy, allowing us to differentiate photons and electrons from hadrons.

When an electromagnetically-interacting particle enters a lead tungstate crystal it interacts with the molecules causing various excitations followed quickly by decays that emit a photon (scintillation). Concurrently, an electromagnetic shower develops creating more electrons and photons to interact and produce more scintillated light. The photons from these scintillations are collected by avalanche photodiodes (APDs) in the barrel and vacuum phototriodes in the endcaps. The APDs are more efficient and have more gain, but the VPTs have larger coverage which is necessary for the larger endcap crystals. The scintillation light emitted by the crystals has a broad maximum in the blue-green region of the spectrum at 420-430 nm. The scintillation yield is quite small; only 4.5 photoelectrons per MeV reach the photodetectors.

The ECAL barrel consists of 61,200 crystals and has coverage up to an $|\eta|$ of 1.479. Each crystal is 23 cm long and 22 mm \times 22 mm across (one Molière radius) at the front face. The length corresponds to $25.8X_0$. Each crystal covers 0.0174×0.0174 in $\eta - \phi$ space. The endcaps cover $1.479 < |\eta| < 3.0$ with 7,334 crystals in each endcap. These crystals are 22cm long and have a slightly larger front face cross section of 28.62 mm \times 28.62 mm. The layout of the ECAL can be seen in Figure 3.5.

The ECAL system also includes the Preshower Detector (ES) which is located between in front of the endcap and covers the $|\eta|$ range from 1.653 to 2.6. This is a two layer detector consisting of a layer of lead radiator to induce electromagnetic showers from electrons and photons passing through it and a layer of silicon strip sensors to measure the energy and transverse shape of these showers. The preshower is primarily used for identifying neutral pions in the endcaps, but also to improve the measurement of photon and electron positions in the endcaps and differentiate between electrons and minimum ionizing particles. For some analyses, the ability to differentiate true single photons from the diphoton system

resulting from a π^0 decay at high momentum is very important.

3.4.1 ECAL Performance and Calibration

The CMS ECAL has excellent energy resolution up to about 500 GeV, at which point energy leakage out of the back of the crystals becomes important. The resolution can be described by:

$$\left(\frac{\sigma}{E}\right)^2 = \left(\frac{S}{\sqrt{E}}\right)^2 + \left(\frac{N}{E}\right)^2 + C^2, \quad (3.2)$$

where S is the stochastic term, N is the noise term, and C is the constant term. During test beam studies, a typical energy resolution had a value of $S=2.8\sqrt{\text{GeV}}$, $N = 0.12 \text{ GeV}$, and $C = 0.30\%$. For 120 GeV electrons a resolution better than 0.5% is possible.

To achieve such good energy resolution, precise calibration is essential. The estimated energy, E , of a particle is given by:

$$E = F \cdot \sum_{\text{cluster crystals}} G(\text{GeV}/\text{ADC}) \cdot C_i \cdot A_i \quad (3.3)$$

where F is a factor depending on particle type, energy, and η , G is the overall ECAL energy scale (absolute calibration factor), C_i are the crystal-by-crystal calibration constants, and A_i are the uncalibrated RecHits (individual crystal energies in the calorimeter). G and the C_i s must be precisely determined and monitored carefully.

One complication is the dependence on temperature of both the number of emitted scintillation photons and the amplification of the APD. The effect is a decrease of $3.8 \pm 0.4\%$ per degree Celcius. To keep the constant term in the resolution function below 0.5% the temperature of the ECAL constant to within 0.05 °C in the barrel and 0.1 °C in the endcaps, the nominal operating temperature of the ECAL is 18.0 °C. Also contributing to the constant term is the changing transparency of the crystals due to radiation damage.

The first calibrations were done before the ECAL was installed using cosmic rays, high energy electrons from test beams, and other laboratory measurements. This brought the calibration between crystals to about 1.5 - 2.0%.

The best precision for the inter-calibration comes from physics events. CMS uses a couple different techniques. One way of calibrating is to require ϕ independence. There is no preferred ϕ angle in CMS, so the ϕ rings of the detector can be quickly calibrated by requiring the same average response in each crystal in a given ϕ ring over some large number of events. No special events are required, so getting a large sample quickly is simple and easy.

This symmetry does not exist in η , so processes like $W \rightarrow e\nu$, $\pi^0 \rightarrow \gamma\gamma$, and $\eta \rightarrow \gamma\gamma$ are used to do the inter-calibration during early running. Here the C_i s are determined by reconstructing the π^0 mass many times using the same crystal. Then the shift in the mass relative to other crystals can be extracted. This technique can inter-calibrate the ECAL to a precision of better than 1%. In the long term, $Z \rightarrow ee$ can also be used, but the production cross section is rather small for use in early running. All these inter-calibration techniques will be limited to regions in η due to systematic variations like tracker thickness, the structure of the ECAL (notably, differences between the barrel and the endcap), and variations in the backgrounds to the physics process of interest.

The π^0 and η^0 can be used to determine the overall energy scale of the ECAL before the requisite luminosity is collected to implement the calibration using Z s. The π^0 has a well known mass and is produced copiously at CMS. By reconstructing its mass many times we can calculate the overall deviation from the expected mass giving us the value of G . The heavier η^0 can be used similarly.

Furthermore, a calibration to monitor quickly evolving changes in transparency of the crystals under irradiation must be performed. The crystals are quite radiation hard, but ionizing radiation does cause damage that affects light transmission through the crystals. For this a laser system is employed. During the beam gaps, the laser is pulsed into the calorimeter crystals to track the changes in transparency. A full scan of the ECAL will happen approximately every 30 minutes.

3.5 The Hadronic Calorimeter

Encircling the ECAL but still inside the solenoid is the hadronic calorimeter (HCAL). The barrel and endcap portions of the HCAL are sampling calorimeters consisting of alternating layers of cartridge brass and scintillating plastic. The brass serves to induce showering from hadronic particles passing through it. The resultant particles then cause scintillation in the plastic that is collected by wavelength shifting fibers and detected by a hybrid photodiode (HPD). Brass was chosen because it is nonmagnetic, but allows for a large number of interaction lengths within the confines of the solenoid at a reasonable cost.

The HCAL barrel (HB) ranges in thickness between 5.82 and 10.6 interaction lengths (λ_I) and covers $0 < |\eta| < 1.3$. In the barrel, the $\eta - \phi$ granularity of the detector is $\Delta\eta \times \Delta\phi = 0.087 \times 0.087$. Though there are 17 layers of scintillating plastic longitudinally, all of the layers covering the same $\eta - \phi$ region (tower) are read out together, so there is almost no shower depth information in the HB. The exception to this are the two η regions closest to the endcap which have two independently read out depths. Additionally, the last tower (16) overlaps with the first HCAL Endcap (HE) tower (Figure 3.6).

The HE covers the $|\eta|$ region between 1.3 and 3.0. There are generally two depths read out separately in the endcaps, and three at the highest η regions. The granularity of the endcap matches the granularity of the barrel up to $|\eta| = 1.6$. For $|\eta| \geq 1.6$ the granularity is reduced to $\Delta\eta \times \Delta\phi = 0.17 \times 0.17$.

In the barrel region, the combined depth of the ECAL and HCAL are not enough to contain the hadronic showers in CMS, so an additional part of the HCAL called the Outer Calorimeter (HO) is placed outside the solenoid region. It is two layers read out together in the most central region and one layer in the outer part of the barrel. The solenoid acts as the absorber for the HO bringing the minimum depth of the calorimeter to 11.8 interaction lengths everywhere except at the barrel-endcap transition region. The granularity of the HO is approximately the same as the barrel granularity. The active detector region is again a plastic scintillator with wavelength shifting fibers interfaced to a photodetector.

The Forward Calorimeter (HF) is used mainly for making the luminosity

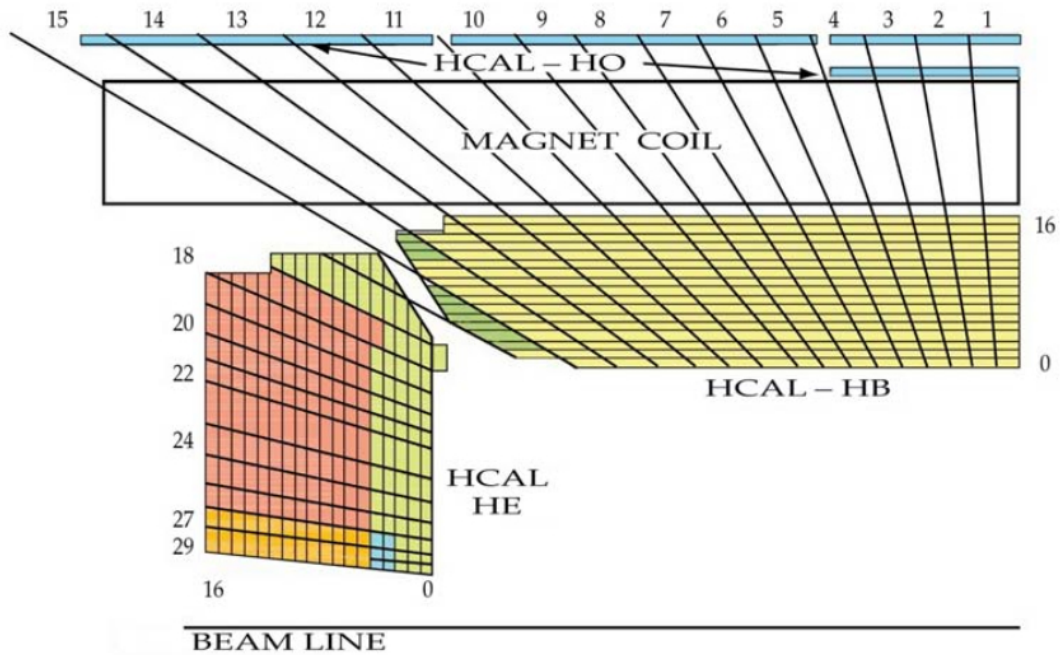

Figure 3.6: A $r - z$ depiction of a quarter of the CMS HCAL. Different colors denote regions read out separately.

measurement. This detector is situated 11.2 meters from the interaction point and covers the $|\eta|$ range up to 5.2. The main design constraint is the radiation hardness necessary for the detector to survive about 10 years. The absorber is steel and quartz fibers are the active material. The fibers will collect Cherenkov light emitted by showering particles.

Like the ECAL, the HCAL relies on various calibration techniques to maintain good performance. The barrel scintillator tiles have an embedded Cs^{137} or Co^{60} source and are also instrumented with an additional fiber through which ultraviolet laser light can be injected. Individual tiles can be calibrated to better than 2% using these systems.

3.6 The Muon System

The muon system of CMS consists of three separate types of gaseous detectors working together to provide precise information about muons produced at

CMS. The detectors are interleaved with the iron of the return yoke. The barrel region, $|\eta| < 1.2$, is covered by four layers (stations) of drift tube chambers (DTs); about 250 chambers in all. The endcaps, $0.9 < |\eta| < 2.4$, are instrumented with cathode strip chambers (CSCs). Both barrel and endcaps also have resistive plate chambers (RPCs) installed as a triggering system; a triggering system is used to select which events are to be saved for later analysis. Much more information about triggering is in the next section. The layout of the muon system can be seen in Figure 3.7.

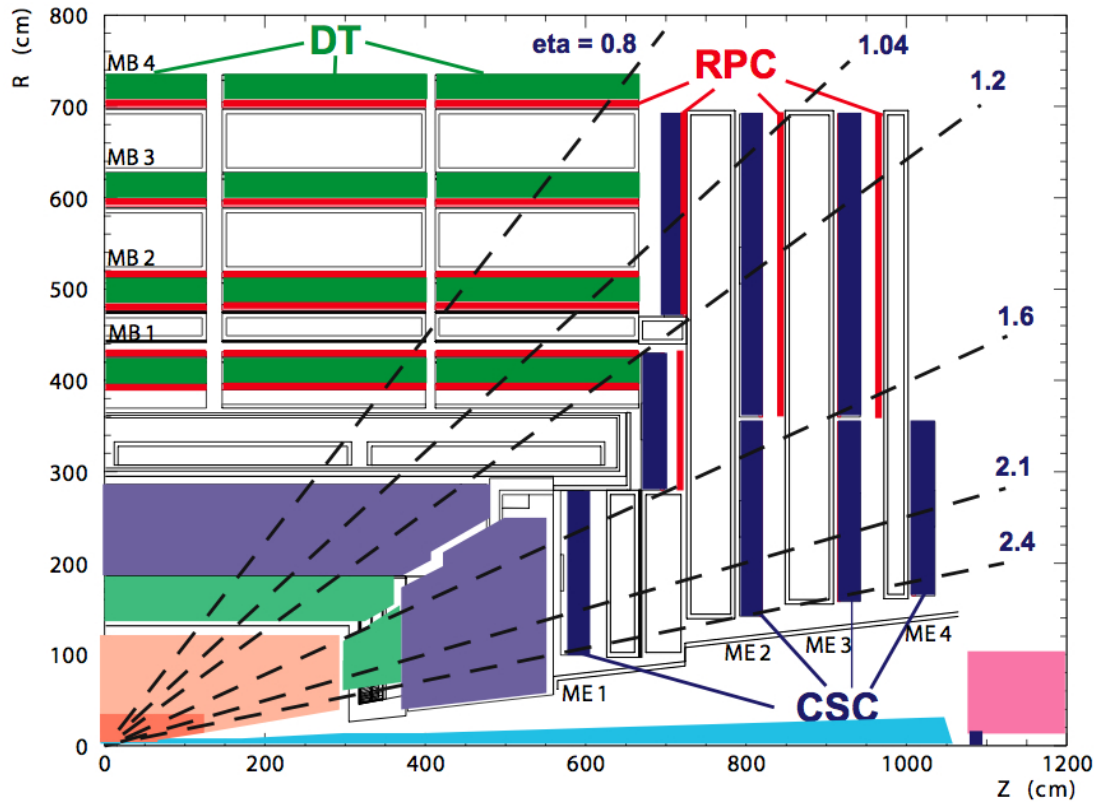

Figure 3.7: A $r - z$ depiction of a quarter of the CMS Muon system. Different colors denote the different types of detectors. Below $r = 300$ cm the blue shows the HCAL, the green the ECAL, and the pink the two layers of silicon trackers.

Note that the accurate reconstruction of muons also relies on the inner tracking system to provide good momentum resolution. By matching tracks in the muon systems to tracks reconstructed in the inner tracker these two independent measurements combine to give a resolution of $\geq 99.2\%$ in the barrel and 97.6% in

the endcaps.

In the barrel, the muon flux and the magnetic field strength are both rather low enabling the use of DTs to measure muon properties with excellent coverage and good timing resolution. In the first three stations of the barrel muon system two thirds of the chambers measure the muon position in the $r - \phi$ plane and the remaining chambers measure in the z direction. In the outermost station all the chambers measure in the $r - \phi$ plane.

In the endcaps ($0.9 < |\eta| < 2.4$) the muon flux is much higher and therefore cathode strip chambers (CSCs) are employed. These detectors have finer segmentation, a fast response and can withstand the higher levels of radiation.

Finally, resistive plate chambers (RPCs) are installed in both the barrel and endcaps (up to $|\eta|$ of 1.6) as a dedicated triggering system. These detectors are very fast ($\approx 2\text{ns}$) and will perform reliably even in the case of higher than expected backgrounds at design luminosity.

There are more than 16 interaction lengths of material between the interaction point and the muon system making punch-through minimal, but there is background from atmospheric muons that must be controlled.

3.7 The Trigger and Data Acquisition Systems

The Trigger and Data Acquisition System (TriDAS) serves two important services in CMS; the collection and filtering of the interesting data. The data production rate at CMS is overwhelming. The nominal interaction rate is 40 MHz. It would be impossible to keep the information about every collision in the detector, and also uninteresting. Most collisions do not result in a process that is useful to the physicists involved in this experiment. The number of events recorded for later analysis must be reduced to a rate of 100 Hz by a two step filtering system. The first is a hardware-based decision that happens underground in the CMS cavern. The second is software-base system installed on a computing farm aboveground at P5.

Let us first trace the path of an interesting physics event that would pass

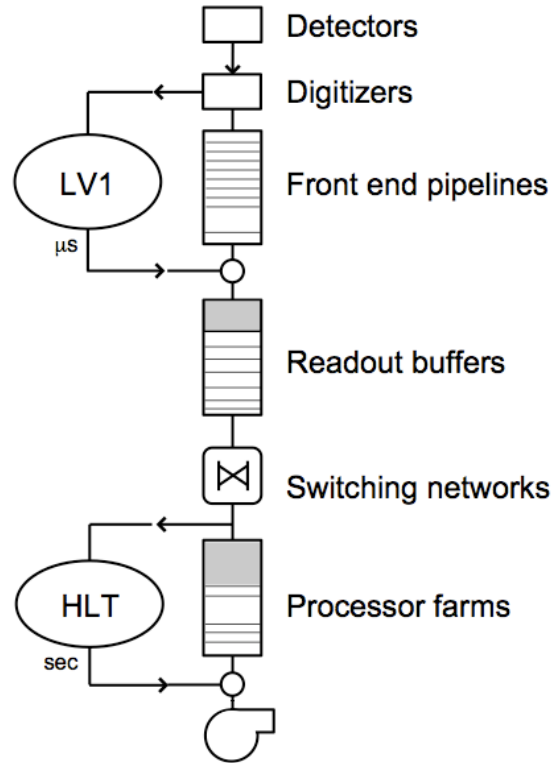

Figure 3.8: A schematic of the TriDAS of CMS [45]

both levels of triggering in CMS. We start at the time of a bunch crossing where proton bunches meet and an interaction creating interesting physics occurs. Signals from each subdetector are collected and sent into the first stage of the TriDAS, the front-end drivers (FEDs). The data will be stored here for $3.2 \mu\text{s}$ while the first level of triggering decisions happen. Front-end readout links (FRLs) then take the data of one FED or the merge the data of two FEDs and sends this to the FED builders. The FED builders assemble data from the FRLs into larger “super fragments” and then sends all the fragments from a single event to the event builders to finish the consolidation of all the fragments into a full event. The complete event is then sent to the filter farm where the HLT makes the final determination on whether the event is written out to be stored for physics analysis or discarded.

In the following, more details of the various stages of triggering and event

readout are described.

3.7.1 The Level 1 Trigger

The first stage of data filtering is a hardware system called the Level 1 (L1) Trigger. This system uses coarse-grained information from the muon and calorimeter subsystems to decide whether an event should be looked at more carefully in about $1 \mu\text{s}$. The rest of the total $3.2 \mu\text{s}$ is taken up by the amount of latency in the system from simply moving the data from the detector[46]. This limit arises from the amount of storage in the tracker and preshower front-ends and corresponds to 128 bunch crossings at 25 ns bunch spacing. The tracking and preshower subsystems do not contribute to the L1 decision, but will contribute to the High Level Trigger (HLT) decision if the event passes the L1 trigger. The L1 system must reduce the 40 MHz interaction rate to a 100 kHz accept rate[47].

There are three separate triggering systems in the muon chambers, the drift tube trigger (barrel only), the cathode strip chamber trigger (endcap only), and the resistive plate chamber trigger (barrel and endcap). Data from each of these three muon systems are combined into a global muon trigger. Information about minimum ionizing deposits from the calorimeter system are also integrated in the process of L1 muon triggering.

The ECAL, HCAL and HF calorimeters are also involved in triggering [47]. For this analysis, only the calorimeter triggers will contribute, so they will now be discussed in further detail. An overview of the whole L1 system is depicted in Figure 3.9.

Calorimeter Triggers

At each bunch crossing various sums of trigger tower energies are computed for the ECAL, HCAL and HF. In the ECAL a trigger tower is a 5×5 array of crystals in the barrel and the “supercrystals” in the endcap which approximately vary in size to match with the HCAL trigger towers (from 25 crystals at $|\eta|=1.5$ down to 10 crystals at $|\eta|=2.8$). In the HCAL barrel a trigger tower is a sum of two longitudinal segments and in the endcap it is a sum of two or three segments. The

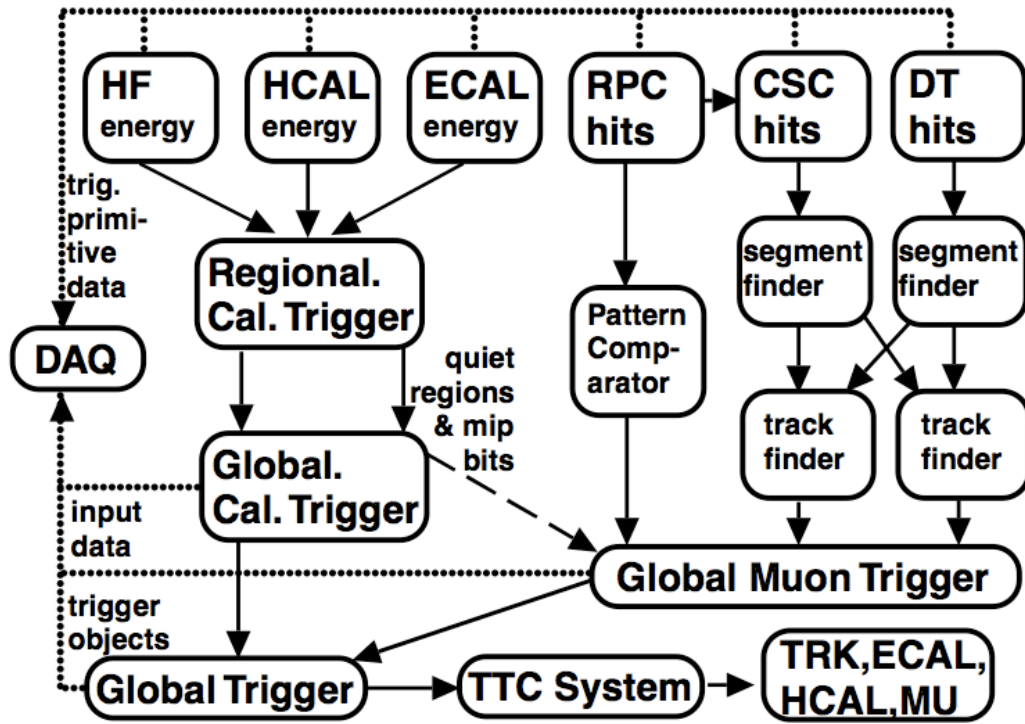

Figure 3.9: The layout of the L1 system [47].

HF does not participate in the electron/photon triggers, so its binning is coarser, but matches with the trigger tower boundaries in the HCAL [47].

For each trigger tower, a trigger primitive consisting of the transverse energy of the tower and a bit denoting the lateral spread of the shower is sent to the L1 calorimeter trigger at each bunch crossing. The lateral spread allows photons and electrons to be differentiated from hadronic activity fairly well. The calorimeter organizes this information and then the 4 most energetic isolated and non-isolated electron/photon candidates, jets in central ($|\eta| < 3$) and forward ($3 < |\eta| < 5$) regions, τ -like jets, and various E_T sums are sent to the global trigger [47]. Electron and photon triggers look for large energy deposits in a single trigger tower or two adjacent trigger towers, a narrow lateral shower profile, and a low value of the ratio of energy in the hadronic towers behind the shower to the electromagnetic energy (H/E).

Global Trigger

Once the muon and calorimeter triggers have been ordered in E_T they are sent to the global trigger. The global trigger synchronizes the information from the muon and calorimeter systems and provides the accept/reject decision. Once an event is accepted by the global trigger, the data stored in the FEDs during this decision is sent to the data acquisition system.

3.7.2 Data Acquisition

The data acquisition system (DAQ) receives the data from subdetectors, merges the various detector outputs into complete events, and moves it physically from the cavern to the surface. It must also provide high level trigger (HLT) decisions and data quality monitoring (DQM) services.

Event Readout

The DAQ interfaces to each detector subsystem via a front-end driver board (FED). This connects the custom hardware of each detector component to the read-out for that subsystem and the trigger. There are between 1 and 438 FEDs per sub-system. Typically, the output of a pair of FEDs is combined by the front-end read-out links (FRLs) to a fragment of $\sim 2\text{KB}$ in the cavern underground and is sent to the surface via Myrinet fibers. Next, the information from up to 8 FRLs is assembled into a super-fragment by the Myrinet network interface card (NIC) based on event number. Myrinet is an optical fiber technology that allows for the efficient transfer of data from the cavern to the surface, a distance of about 200m at a rate of 300MB/s. Myrinet technology was chosen over Gigabit ethernet due to its faster link speed.

The super-fragments are then distributed to the read-out units (RUs) where they are organized and then sent to a builder unit (BU) for the event to be fully assembled. The RUs and BUs are housed in the same PCs in a “trapezoidal” setup that eliminates the need for a separate network for each system. There are 640 Dell 2950 dual dual-core PCs with Myrinet NICs and PCI Express cards installed

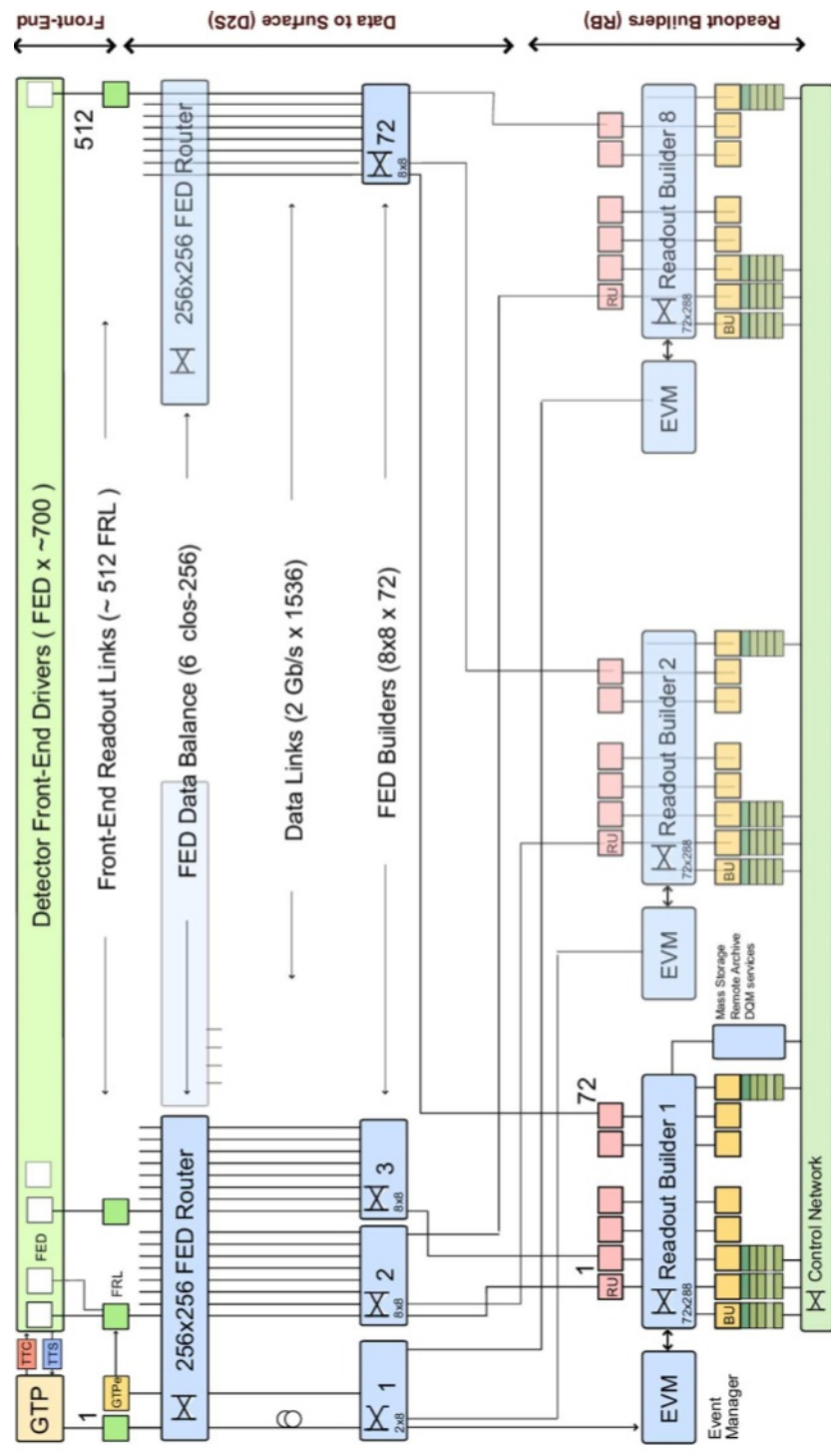

Figure 3.10: A detailed schematic of the DAQ system [46].

acting as the readout and builder units. The complete event is stored in the BU until a final triggering decision is made. The filter units (FUs) are where the second level of triggering (high level trigger) happens. 720 Dell 1950 dual quad-cores make up the filter farm.

Data from all channels cannot be kept because the event size would be far too large. Therefore the data is reduced using zero-suppression in most subsystems and a “selective readout” in the ECAL. This means only regions of the detector with energy deposits above some thresholds (and the adjoining regions in the ECAL) actually send data to the readout units and beyond. The average event size for 2010 running (taking the instantaneous luminosity to be $150\mu\text{b}^{-1}\text{s}^{-1}$) is about 380kB. This increases with luminosity due to pile-up which will be discussed in more detail later. The system can handle average event sizes up to 1 MB.

Another important feature of the DAQ is its modularity. The modularity is important during data taking because it provides necessary redundancy in case of problems like PC or networking failure. The readout system is divided into 8 independent “slices” that make it possible to mask a slice for maintenance while leaving the rest of the system in working order. This is important for keeping the DAQ functioning properly and ready for data taking and much as possible.

Due to ever-improving computing resources and increasing instantaneous luminosity being provided by the LHC it is important to be able to upgrade the various components of the DAQ. Specifically, the readout units, builder units and filter units are all commercially available PCs that can be easily upgraded as needed. The switching technology used for these networks is also upgradable.

3.7.3 High-Level Trigger

The High-Level Trigger (HLT) runs in the filter farm and makes a decision whether or not to keep each event that passes the L1 trigger. The vast majority of events failed by the HLT are discarded, but a few are kept for performance monitoring since a malfunction of the HLT could quickly result in the loss of many desirable events.

In order to make a decision, the relevant parts of the event must be re-

constructed. Which particular subsystems or regions of subsystems are fully reconstructed depends on which trigger path is being evaluated. Reconstructing full events would require a lot more time and computing resources than are available. The trigger path is determined from the “L1 seeds”, or the cause of the L1 accept.

For example, when an L1 seed is an electron, first the region of the ECAL within a certain $\eta - \phi$ window is reconstructed looking for an energy deposit that matches the seed. If this succeeds, then the path of the electron candidate is propagated back through the tracker all the way to the pixels searching for a “pixel match”. If this is also successful then all the tracks in a given region are reconstructed. Various quantities related to the quality of the electron candidate are now computed and used to make the final decision to accept or reject the event. A similar procedure is used for each type of L1 object, some requiring more and others less of the detector information to be reconstructed.

The definition of the set of trigger paths used during a particular run or set of runs is called the trigger menu and can be changed at any point during running in response to various situations. Some paths, particularly those used for calibration, data quality monitoring, and with loose requirements are “pre-scaled” meaning only some fraction of events that would pass the trigger requirements are kept; even this can be changed on the fly. In the end, this flexibility allows the experiment to keep the rate of events passing the HLT to 100 Hz while continually adjusting to keep the best set of events possible.

3.7.4 Data Quality Monitoring

Since the DAQ is the first system to have access to full events, it is also the first opportunity to check the quality of the data. There are two main on-line data monitoring approaches used in CMS. One is the event display which allows for the viewing of individual events (see an example event display in Figure 3.11). This type of event view lets the user visually check for any behaviors such as oddly shaped tracks or strange patterns in the calorimeters. Events for this monitoring come directly from those recently accepted by the HLT providing a nearly real-time opportunity for catching detector response or reconstruction anomalies.

The other system accumulates statistics over many events allowing users to look for problems like channels that are constantly firing or consistently sending higher values than average. These problems would not necessarily be visible in a single event, but can cause problems if not identified and corrected in a timely fashion.

There are two different full detector event displays available in CMS, and some subdetectors also have additional dedicated event displays do event-by-event monitoring. The set of histograms for the statistical monitoring are specific to each subsystem. The monitoring is done both centrally and at each subdetector station in the control room providing at least two sets of eyes on the data coming out of CMS at all times.

3.8 Beyond the DAQ

After an event is passed by the HLT it is sent from the BU (where it was stored awaiting the HLT decision) to the Storage Manager. This is a set of machines that buffer the selected events and then transfer them to the CMS Tier-0 computing center on-site at CERN. A few days worth of events can be stored before the storage manager fills up and data is lost. Generally, the data is transferred to Tier-0 storage immediately after being sent to the storage manager.

The Tier-0 computing center is where the first full event reconstruction and distribution takes place. A copy of every event in its RAW event format is kept there and also sent to one of 8 Tier-1 centers around the world. The data are organized into primary datasets based on trigger information and the prompt calibration is applied. The RAW data is then reconstructed and RECO and AOD data formats are also distributed to the Tier-1 centers. Most details of event reconstruction will not be described in this document. Much more information is available in [49], and electron and photon reconstruction will be detailed in Section 4.3. RECO and AOD data formats are the formats commonly used by analysts.

Tier-1 centers also act as permanent storage for RAW data sets. Subsequent reconstructions needed due to updates or corrections to the prompt reconstruction

done at the Tier-0 site will be done at the Tier-1 centers. The data may also be further specialized for specific analyses by skimming at the Tier-1 centers. All the analyst-ready data are then sent to the Tier-2 sites for user analysis. The path of data through this framework is shown in Figure 3.12.

There are about 50 Tier-2 centers that serve as major working centers for CMS users. Most production of the simulated data sets is also carried out at the Tier-2s. These sites are where RECO, AOD, and USER data formats can all be stored and analyzed. The USER format is not centrally produced, but can be created by any CMS user and the “published” so that others around the world can find these custom data sets and analyze them. After the steps of analysis that need the large computing resources of the Tier-2 centers are complete any output can be transferred to local computing resources known as Tier-3 facilities for the completion of an analysis. This tier is not part of the global CMS computing system and is configured specifically for local user needs.

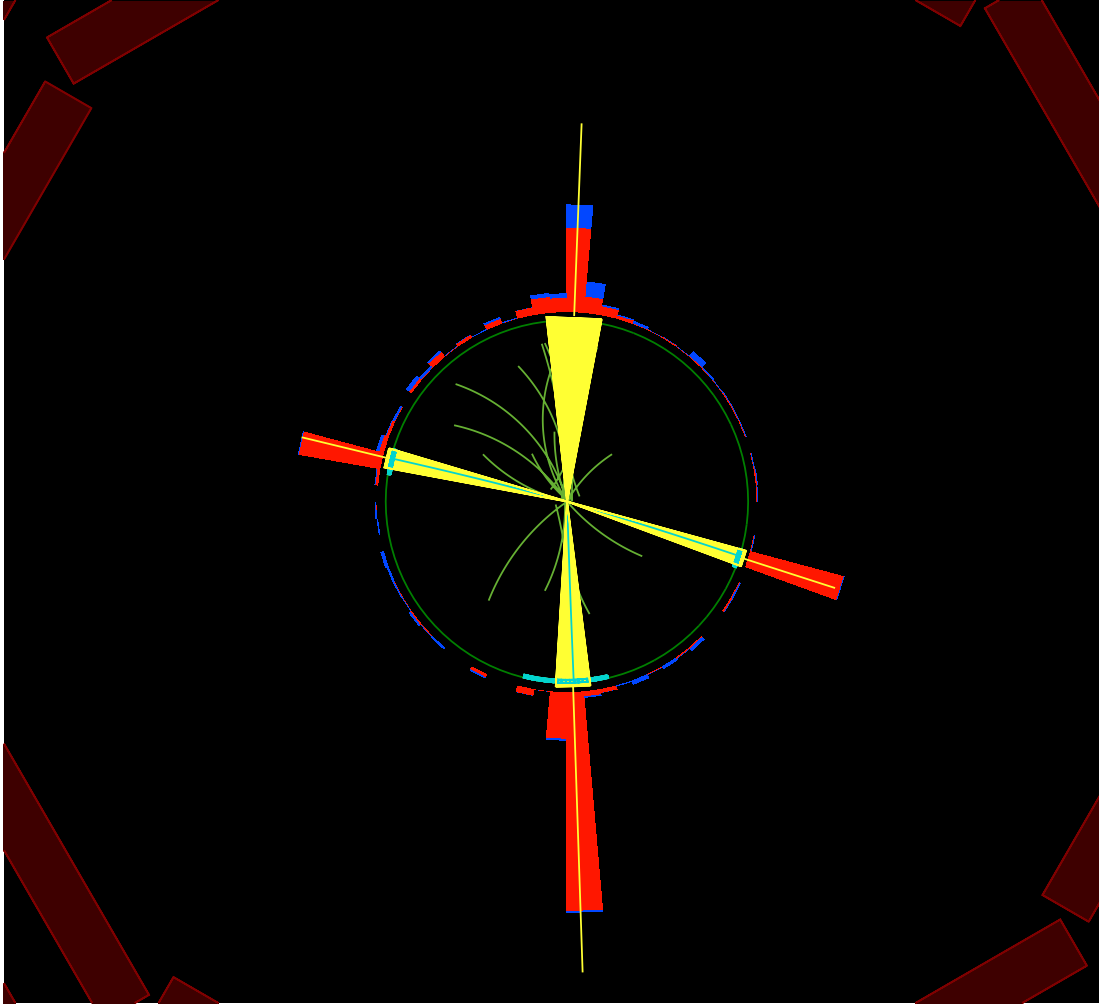

Figure 3.11: An example event display highlighting the tracker and calorimeter systems. The green lines show reconstructed tracks, the red are ECAL deposits, the blue HCAL deposits, and the yellow reconstructed jets (actually electrons and photons in this event).

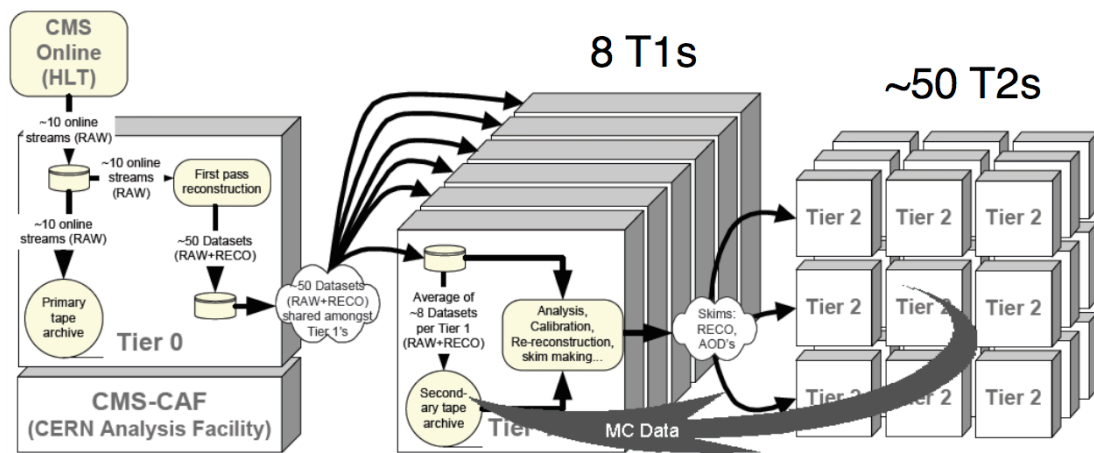

Figure 3.12: A schematic of the path data (and MC) take through the tiered computing system [48]

Chapter 4

Doing Physics At CMS

Now that we have discussed the physics and particles we are searching for (Chapter 2) and the specifics of our instrument (Chapter 3), we can tie these two things together and begin discussing the business of experimental particle physics. We detect six types of particles with CMS:

Electrons are the lightest charged lepton. They travel through the tracker leaving a curved signature from which we can measure their momentum and charge. In the ECAL they shower and deposit almost all of their energy.

Photons are massless and uncharged. Ideally they pass through the tracker without interacting and deposit all of their energy in the ECAL like electrons.

Quarks are not observed singly, and instead are only observed in a hadronized state. The mesons and baryons that result from this hadronization process are both charged and uncharged. The charged hadrons pass through the tracker leaving behind curved tracks while the uncharged ones sail through undetected. Both charged and uncharged pass through the ECAL without leaving much energy and instead deposit the bulk of their energy by showering in the HCAL. Most quarks hadronize by producing multiple collimated hadrons that are reconstructed as a “jet.”

Gluons, like quarks, are not found free in nature and also produce jets.

Muons are the second lightest charged lepton. They are sufficiently stable to usually pass through the entirety of CMS without being absorbed. They will leave a track in the tracker and in the muon systems allowing us to measure their momentum and charge.

Neutrinos only interact via the weak interaction and will pass through all of CMS without leaving trace. We must infer their existence by computing ΣE_T for the event. If it is sufficiently large (small amounts of ΣE_T can come from mismeasurement), then we conclude that this difference was carried away by a particle or particles we did not detect.

For this thesis we will concentrate only on electrons and photons since they comprise the final state of the excited electron analysis.

4.1 Particle Physics Analysis Software

Particle physics is somewhat of a special case in experimental science because there is no “control” universe to compare our results to. We instead have the observations of past experiments and theoretical calculations to guide our work. As described in Chapter 2, the Standard Model is an extremely successful theory that describes the observations of many, many experiments over the years. The procedure in particle physics is to use this knowledge combined with (lots of) computing power and theoretical calculations to “generate” sets of events that we expect based on the Standard Model theory and then pass them through a very detailed simulation of what response the CMS detector gives. We design our search based on this simulated data and then look in the true data collected by the experiment to see if we have found new physics or can place limits on the allowed parameters of the investigated theory.

This analysis searches for physics that is not part of the Standard Model. We use software that generates Monte Carlo (MC) events according to the model designed by theorists (Section 2.3). We then look for features of the model that will set it apart from the Standard Model processes that we know occur. In the end,

the data will have one answer and we must evaluate whether it is more consistent with the MC simulations of the Standard Model or our novel physics. We also use MC data sets of some of the known backgrounds to design the search and interpret the findings.

A single code framework, CMSSW, is used for many of the different tasks needed by users to perform physics analysis. It is used for data related tasks (online triggering, event reconstruction, data-quality monitoring), for implementing the generation, simulation and reconstruction of MC data sets, and even for user-level tasks such as event skimming and the analysis of data and MC events. For this thesis private code *not within* the CMSSW framework was used for the skimming and final cut application, plotting, etc. All of the steps preceding the final analysis were done within the CMSSW framework.

4.1.1 Generation

A generator uses theoretical calculations to produce data sets of events with the desired distributions of final states. One can run a generator telling it, for example, to collide two protons and produce a Z boson and decay the Z boson to two electrons. Thousands and millions of events can be quickly produced that replicate with remarkable accuracy the distributions of observables for this process that are seen in nature.

Two different generators are used in this analysis, PYTHIA and MadGraph. PYTHIA is what we use for the generation of the signal and most of the background processes. PYTHIA is also used for the fragmentation and parton showering of the generated particles before the simulation process begins for all the samples. It starts from a proton-proton collision and then creates the distributions of outgoing particles including the hadronization of the quarks and gluons and the decay of short-lived particles[50].

MadGraph is a matrix element generator that calculates full tree level amplitudes that are then passed to the related software, MadEvent. MadEvent produces parton level events in a format that can be inputted to PYTHIA for the showering step [51]. Matrix element generators are typically better at correctly

handling the “edges” of a process, such as a high transverse momentum (p_T) tail [52]. This generator will be used for our main background since we are most interested in the very high p_T tail of that process.

4.1.2 Simulation

Once the showering work of PYTHIA is done, the events are fed into a software package based on GEANT4. This software package is used to make a detailed simulation of what interactions the input particles undergo as they pass through both the active and inactive volumes of the CMS detector. Long-lived particles are decayed by GEANT during this step [53].

Finally, the responses of the detector elements must be simulated. This process is called digitization. After digitization we have events in a form that matches up with the data collected by CMS. From here on, the data and MC are treated in largely the same way. The main difference is that the MC data sets have a few extra sets of information containing the “MC truth”. This information helps physicists to study what is *truly* happening when they apply cuts. It is useful to know if one is selecting the objects they really want or just good imposters, and this is not something you can study in data.

4.1.3 Reconstruction

Following collisions (digitization in the case of MC data sets) the detector signals of each subdetector are stored in an undigested format not easily used by physicists. The signals must be “reconstructed”. Reconstruction is the process of taking the millions of electronic signals and interpreting them as physics objects like electrons and photons. During this procedure many properties of the physics object are computed. The average event processing time varies between 1.2-2.6 s (min bias - jet trigger) depending on the complexity of the event [49].

The data that comes out of the detector as electronic signals (RAW format) is output as a data format called RECO or AOD. This data format has in it the photon and electron collections that comprise the starting point for the following

analysis. It also has triggering information and, in the simulated datasets, MC truth generator information.

For this particular analysis a private code framework has been used. The RECO or AOD level CMSSW data files are the input to a CMSSW analyzer, and the output is a flattened ROOT [54] ntuple. These ntuples are further analyzed with a C++ program that can output histograms, efficiencies, and further selected sets of events while properly keeping track of parameters such as the event weight.

4.2 A Few Notes on Proton-Proton Collisions

At CMS the two beams of protons circulating in opposite directions in the LHC are squeezed and crossed resulting in proton-proton collisions. As is discussed in Chapter 2, protons are not point particles colliding to produce nice simple final states like two high p_T electrons. The situation inside the proton is very complicated. There are the three valence quarks, but then also lots of “sea” quarks and gluons constantly being produced and annihilated, though always conserving color and quark flavor. At the LHC, most often an interaction is between two gluons rather than the quarks making up the protons. The distributions of the fraction of the proton’s momentum carried by the various constituent particles are measured as well as possible with deep inelastic scattering experiments. The resulting fits are called parton distribution functions (PDFs) and used to reproduce as closely as possible the physics observed at CMS [55].

When protons collide at CMS what is really happening is writhing masses of quarks and gluons are being flung together and occasionally a hard interaction occurs. After an interaction occurs the protons are broken up and the parts of the proton not creating the interesting physics must hadronize and deposit their energy in the detector as well. The modeling of the hadronization process is very difficult to do precisely. The deposits in the detector from the proton remnants is known as the underlying event.

Also complicating matters are the concurrent pile-up events that happen with almost every interesting collision. Each proton bunch contains so many pro-

tons that at each bunch crossing more than one pair is likely to interact. The probability of having a given number of pile-up events is given by:

$$P(n_{pu}) = \frac{(\mathcal{L} \times \sigma)^{n_{pu}}}{n_{pu}!} \times e^{-(\mathcal{L} \times \sigma)} \quad (4.1)$$

where n_{pu} is the number of pile-up events, \mathcal{L} is the instantaneous luminosity, and σ is the total pp cross section. The maximum value of \mathcal{L} for the 2010 run was about $205 \mu\text{b}^{-1} \text{s}^{-1}$ [56]. These interactions are just uninteresting scattering events, but will deposit some energy in the detector. The effect will be higher than expected values for some types of quality variables (such as isolations) used in the analyses. For the 2010 running the effect of pile-up events was simply treated as a systematic error for the e^* analysis because the effect is not large. As the number of protons per bunch increases, a more sophisticated treatment will become necessary.

4.3 Photon and Electron Reconstruction

4.3.1 Electromagnetic Clusters

All photons and electrons detected by CMS start out their lives as energy deposits in the ECAL. A photon enters a crystal and interacts with the PWO_4 causing an electromagnetic shower of photons and electrons. In the barrel, only about 70% of an unconverted photon's energy is deposited in the crystal that it impacts the center of. The shower spreads to neighboring crystals creating a cluster of crystals with energy deposits in the ECAL. 94% of a single unconverted photon's (or electron's) energy is deposited in a 3×3 array of crystals, and 97% in a 5×5 array.

A simple 5×5 clustering would be all that is necessary but for the fact that on their way to the ECAL photons must pass through the tracker material and can often undergo conversion, resulting in an electron-positron pair. Electron and positron paths bend significantly in ϕ due to the high magnetic field, so multiple smaller clusters are often created spread out in ϕ . These are associated with the main cluster into a "supercluster" using the Hybrid algorithm in the barrel and the Multi 5×5 algorithm in the endcaps. The Hybrid algorithm takes a fixed shower

width of 5 crystals in η and then searches dynamically in ϕ (up to 35 crystals) to build a supercluster. The Multi 5×5 algorithm adds together 5×5 blocks of crystals to build the supercluster. The supercluster position in the endcap is extrapolated to the preshower detector (ES) and any energy deposited there is also added to the supercluster energy [57],[40].

Energy corrections are made to account for variations in the shower position relative to the cluster boundary, the amount of rear leakage due to showers near cracks, and the spread of energy in the ECAL due to bremsstrahlung and photon conversion in the tracker.

4.3.2 ECAL Anomalous Signals

When a new detector comes on-line one of the most important tasks is checking that everything works as planned. In the case of the ECAL the commissioning resulted in the discovery of “spikes” in the data from the barrel section of the detector. These isolated high energy deposits are likely caused by the direct ionization of the APDs by protons and other heavy ions. The spike frequency is about 1 in 1000 minimum bias events [58].

Very quickly a few different techniques for flagging and rejecting these anomalous deposits were devised. For this analysis the “Swiss Cross” variable is used on-line to remove the deposits from the events before reconstruction. This variable is defined as the $E1/E4$ where $E1$ is the energy of the highest energy crystal in the cluster and $E4$ is the sum of the 4 adjacent crystals in η and ϕ . Off-line variables for removing any remaining spikes include the timing of the RecHits and $E2/E5$. $E2$ is the sum of 2 highest energy crystals in the cluster.

4.3.3 Photon Reconstruction

The photon collection is created with the corrected supercluster collection as its starting point. Each supercluster’s R_9 value is computed. R_9 is the value of the sum of energy in the 3×3 array of crystals surrounding the seed crystal divided by the supercluster energy. It is a good indicator of whether or not a

photon converted in the tracker. Photons with R_9 values greater than 0.94 (0.95) in the barrel (endcap) are considered to be unconverted and the photon energy is taken to be the sum of energy in the 5×5 array of crystals surrounding the seed crystal. If the R_9 value is less than 0.94 (0.95), the photon likely converted in the tracker and the supercluster energy is used instead. The E_T of the photon is taken relative to the reconstructed primary vertex [59].

As there are very few requirements on the supercluster and photon collections, the majority of the reconstructed photon collection is not actually photons, but other particles that create a cluster in the ECAL such as electrons and jets. This makes it important to make a further selection on the photon collection to obtain a sample of objects that are likely to be true photons.

4.3.4 Electron Reconstruction

An electron is detected by CMS as an electromagnetic cluster in the ECAL matched to a track from the tracker. There are two algorithms, “tracker driven” and “ECAL driven”. The “tracker driven” algorithm targets low p_T electrons and electrons in jets, but those electrons that are only found by this method will not be used in this analysis.

The “ECAL driven” reconstruction algorithm starts from the electromagnetic cluster in the calorimeter. All superclusters with $E_T > 4$ GeV are propagated back through the tracker volume to the inner tracker assuming both a negative and positive charge hypothesis. If a hit is found in the innermost or next-to-innermost layer then a triplet or doublet of hits in the pixels is searched for. If found, this seed is the used as the starting point for the building of tracks using a Gaussian Sum Filter algorithm that is optimized to deal with the bremsstrahlung emissions that electrons undergo in passing through the tracker. Many more details of this procedure can be found in [57]. If more than one track is reconstructed the higher quality one is taken so that only one electron is built per cluster and set of tracker hits.

Similarly to the photon collection, there are many objects in this collection that are not truly electrons. We will also further select the electrons likely to be

good with a set of cuts detailed in the next chapter.

Chapter 5

Event Selection

5.1 Data and MC Samples

In 2010 the LHC delivered 47 pb^{-1} to the experiment and CMS recorded just under 92% of this data [60]. In 2010 the peak luminosity achieved was $2 \times 10^{32} \text{ cm}^{-2} \text{ s}^{-1}$ with a 150 ns bunch spacing. December 5th 2009 saw the first physics collisions. Running ended on Friday, 29 October 2010 to leave a month for heavy ion collisions, which was successfully completed as well [61]. The data used for this analysis consists of 36 pb^{-1} included in runs 136035 to 144114 collected in Run A and runs 146426 to 149294 in Run B during data-taking with the CMS detector at $\sqrt{s} = 7 \text{ TeV}$ in 2010. These are the subset of the data declared by the collaboration to have all subdetectors included in the run and functioning properly. The official JSON file, Cert_136033-149442_7TeV_Nov4ReReco_Collisions10_JSON.txt was used to select good luminosity sections from these runs. For Run A, the EG (e-gamma) primary data set is used and in Run B we used the Photon primary data set. The EG primary data set includes all events passing an electron or photon HLT trigger, and the Photon data set includes only the photon triggered events. A further offline filtering is applied selecting only events with a good reconstructed vertex and eliminating beam scraping events[62]. A beam scraping event is when protons contact the collimators upstream of CMS and cause a spray of particles to impact the detector. The specific datasets used are defined in Table 5.1.

MC samples from the Fall10 CMSSW_3_8_X production were used. The

Table 5.1: Datasets used in this analysis.

Run Range	Dataset Name
136035 - 144114	/EG/Run2010A-Nov4ReReco_v1/RECO
146428 - 149294	/Photon/Run2010B-Nov4ReReco_v1/RECO

signals and most backgrounds were generated with PYTHIA [50]. The exceptions are the $Z \rightarrow ee\gamma$ and $W \rightarrow e\nu\gamma$ samples which were generated with MadGraph[51] and then showered with PYTHIA. Table 5.2 shows the samples and cross sections used. For the signal and Born and Box diphoton background samples leading order PYTHIA cross sections are used. The major background to the analysis, $Z \rightarrow ee\gamma$, and the $W \rightarrow e\nu\gamma$ have p_T dependent next-to-leading-order k-factors applied[63]. The other samples (dibosons and $t\bar{t}$) are weighted to next-to-leading-order cross sections.

There was no officially produced $e^* 1000 \text{ GeV}/c^2$ sample, so this mass point (along with a $600 \text{ GeV}/c^2$ and a $1200 \text{ GeV}/c^2$ mass point) was produced privately. The $600 \text{ GeV}/c^2$ officially produced sample was used to validate the privately produced sample and no problems were found. The $1200 \text{ GeV}/c^2$ mass point was simply an additional point used for the analysis.

5.2 High Level Trigger

As described in Section 3.7.3, the HLT reduces the events accepted at L1 by a further factor of 1000. It must make much tighter cuts than the L1, but still loose enough that analyzers are not missing good events. For the e^* analysis the final state has three high E_T particles (two electrons and a photon) that will all leave large deposits in the ECAL. The photon triggers have looser cuts than the electron ones, and the electrons will fire the photon triggers since there is no veto on clusters with matching tracks in the photon triggers. The main cut on the photon triggers is the E_T threshold. We maximize the signal efficiency if we can accept down to quite a low threshold, and since we have three triggerable objects, the diphoton triggers are a reasonable choice for us. The diphoton triggers have

Table 5.2: MC samples and cross sections used in the signal analysis. For the signal the mass is as noted and Λ is chosen to be 4 TeV. Samples are generated with PYTHIA unless marked “MadGraph”

Process	$\sigma(\text{pb})$	Int. Lumi Processed (pb^{-1})
$e^* \rightarrow e\gamma$; $M_{e^*} = 200 \text{ GeV}/c^2$	0.197	1.08×10^5
$e^* \rightarrow e\gamma$; $M_{e^*} = 400 \text{ GeV}/c^2$	0.0809	2.47×10^5
$e^* \rightarrow e\gamma$; $M_{e^*} = 600 \text{ GeV}/c^2$	0.0369	4.80×10^5
$e^* \rightarrow e\gamma$; $M_{e^*} = 800 \text{ GeV}/c^2$	0.0167	9.24×10^5
$e^* \rightarrow e\gamma$; $M_{e^*} = 1000 \text{ GeV}/c^2$	0.00740	8.73×10^6
$e^* \rightarrow e\gamma$; $M_{e^*} = 1200 \text{ GeV}/c^2$	0.00740	1.00×10^7
$e^* \rightarrow e\gamma$; $M_{e^*} = 1500 \text{ GeV}/c^2$	0.00094	4.24×10^8
$Z \rightarrow ee + \gamma$ (MadGraph)	~ 33.7	1.79×10^3
$Z/\gamma^* \rightarrow \tau\tau$	1666	1.23×10^3
$W \rightarrow e\nu + \gamma$ (MadGraph)	~ 141	6.54×10^2
WW	27.79	2.75×10^4
WZ	10.4	1.54×10^5
ZZ	4.297	3.83×10^5
$t\bar{t} \rightarrow 2l2\nu2b$	15.86	3.40×10^4
Born $\gamma\gamma \hat{p}_T$ 25 - 250	22.37	2.17×10^4
Born $\gamma\gamma \hat{p}_T$ 250 - Inf	0.00807	1.00×10^7
Box $\gamma\gamma \hat{p}_T$ 25 - 250	12.37	6.22×10^4
Box $\gamma\gamma \hat{p}_T$ 250 - Inf	2.08×10^{-4}	1.00×10^7
Used for control regions		
$\gamma + \text{Jet } \hat{p}_T$ 15 - 30	171700	6.0
$\gamma + \text{Jet } \hat{p}_T$ 30 - 50	16690	56
$\gamma + \text{Jet } \hat{p}_T$ 50 - 80	2722	250
$\gamma + \text{Jet } \hat{p}_T$ 80 - 120	447.2	1.78×10^3
$\gamma + \text{Jet } \hat{p}_T$ 120 - 170	84.17	6.81×10^3
$\gamma + \text{Jet } \hat{p}_T$ 170 - 300	22.64	4.86×10^4
$\gamma + \text{Jet } \hat{p}_T$ 300 - 470	1.493	5.00×10^5
$\gamma + \text{Jet } \hat{p}_T$ 470 - 800	0.1323	5.00×10^5
$\gamma + \text{Jet } \hat{p}_T$ 800 - 1400	0.00349	5.00×10^5
$\gamma + \text{Jet } \hat{p}_T$ 1400 - 1800	1.270×10^{-5}	5.00×10^5
$\gamma + \text{Jet } \hat{p}_T$ 1800	2.936×10^{-7}	5.00×10^5
QCD $bc \rightarrow e \hat{p}_T$ 20-30	132160	15.6
QCD $bc \rightarrow e \hat{p}_T$ 30-80	136804	14.3
QCD $bc \rightarrow e \hat{p}_T$ 80-170	9360	110
QCD EM Enriched \hat{p}_T 30-80	3.867×10^6	18
QCD EM Enriched \hat{p}_T 80-170	139500	64

lower thresholds and fewer other criteria than the single photon triggers.

It is also important to choose triggers, when possible, that are not pre-scaled both to avoid complication and potential loss of rare events. For the triggers used in early running, there is no problem of unpre-scaled triggers having requirements that are too tight for this analysis, so that is what we use. The lowest unpre-scaled triggers changed as the instantaneous luminosity increased during 2010. For the specific trigger used for the various run ranges, see Table 5.3. These paths are all seeded by “relaxed” Level 1 objects with no H/E cut (.L1R), but some of them have an $H/E < 0.15$ requirement applied at HLT level (SC##HE) [64]. For events with at least two fiducial objects that pass the selection (see following sections) this choice of triggers is 100% efficient[65].

Table 5.3: HLTs used for this analysis.

Runs	Trigger
Run A 136035 – 144114	HLT_DoublePhoton20_L1R
Run B 146426 – 147119	HLT_DoublePhoton17_L1R
Run B 147196 – 148058	HLT_DoublePhoton17_SC17HE_L1R
Run B 148822 – 149294	HLT_DoublePhoton22_SC22HE_L1R

5.3 Object Selection

This section describes the variables and cuts used to choose the electrons and photon for the e^* search. The three objects in the signal events are quite central, so the detector acceptance is quite high. Figure 5.1 shows the single particle and three particle acceptances at generator level for the various e^* masses. These acceptances are detailed in Table 5.4. The three particle acceptance represents the best we could possibly do in terms of signal efficiency. For the reporting of the results of this analysis the term *efficiency* will also include these detector acceptances.

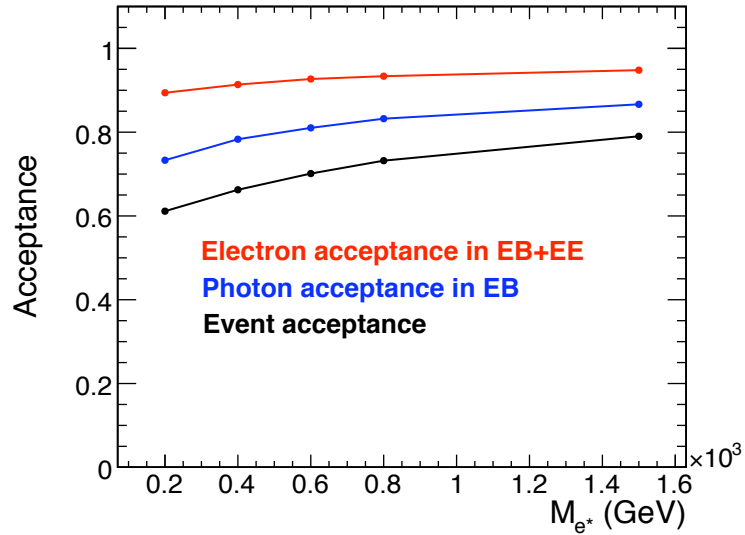

Figure 5.1: Single particle and complete final state acceptances at generator level.

Table 5.4: Generator-level acceptances

M_{e^*} [GeV/ c^2]	γ (EB only)	Single e	$2e + \gamma$ (EB)
200	0.733	0.894	0.611
400	0.783	0.914	0.662
600	0.810	0.927	0.701
800	0.832	0.934	0.732
1500	0.867	0.948	0.790

5.3.1 Photon Identification

The photon collection is largely composed of things that are not real prompt photons; it is better to keep too many objects than to cut any potentially interesting ones. There are many photon variables that can be used to eliminate the number of these misidentified objects from an analysis. To this end, a set of photon identification criteria were developed by the Exotica group for analyses requiring high P_T photons. This selection aims to have high efficiency for high E_T photons, low background, and be stable in the early running phase the detector may not be understood perfectly. There were different optimizations available allowing trade-offs between higher efficiency and better background suppression. For e^* , the photons are at a high enough E_T and background suppression is of such impor-

tance that the tightest cuts were the best choice. Another important consideration in the designing of this selection was keeping the efficiency relatively flat as a function of p_T . This is important since data-driven measurements of the efficiency and jet background contributions will not have enough events with objects at the very high energies where the identification is being applied until much more than 36 pb^{-1} are collected.

The variables used for identification are:

- H/E : H is the sum of energy in the HCAL in a $\Delta R = \sqrt{(\Delta\phi)^2 + (\Delta\eta)^2}$ cone of 0.15. E is the sum of energy in the ECAL in a ΔR cone of 0.15.
- Tracker Isolation: The sum of the p_T of all tracks in a cone of $\Delta R = 0.4$ about the line from the reconstructed primary vertex to the photon's cluster position *minus* the p_T of tracks in an inner cone of 0.04 and an η strip of 0.015 (Figure 5.2). Tracks with $d_{xy} > 0.1$ or $d_z > 0.2$ cm are also excluded from the sum.
- ECAL Isolation: The sum of the E_T of the crystals in a cone of $\Delta R = 0.4$ centered about the photon's cluster position *minus* the E_T of crystals in a cone of 3.5 crystals and an η strip of 2.5 crystals (Figure 5.2).
- HCAL Isolation: The sum of the E_T in a hollow cone with $0.15 < \Delta R < 0.4$ centered about the photon's cluster position.
- $\sigma_{i\eta i\eta}$: A measure of the transverse shape of the photon's cluster:

$$\sigma_{i\eta i\eta}^2 = \frac{\sum_i^{5 \times 5} w_i (\eta_i - \bar{\eta}_{5 \times 5})^2}{\sum_i^{5 \times 5} w_i}; w_i = \text{Maximum}(0, 4.7 + \ln \frac{E_i}{E_{5 \times 5}}) \quad (5.1)$$

- hasPixelSeed: A bool denoting whether the photon position matches to a pixel seed in the tracker.

Jets tend to have higher values of H/E and isolation than prompt photons due to their hadronic component. The removal of the tracks and RecHits in the inner cone for the tracker isolation is to preserve converted photons. $\sigma_{i\eta i\eta}$ is useful in rejecting π^0 s as they have a larger transverse spread than prompt photons. The

hasPixelSeed bool eliminates some jets and also electrons from our selection. Since electrons also leave a cluster of energy in the ECAL they will be included in the photon collection.

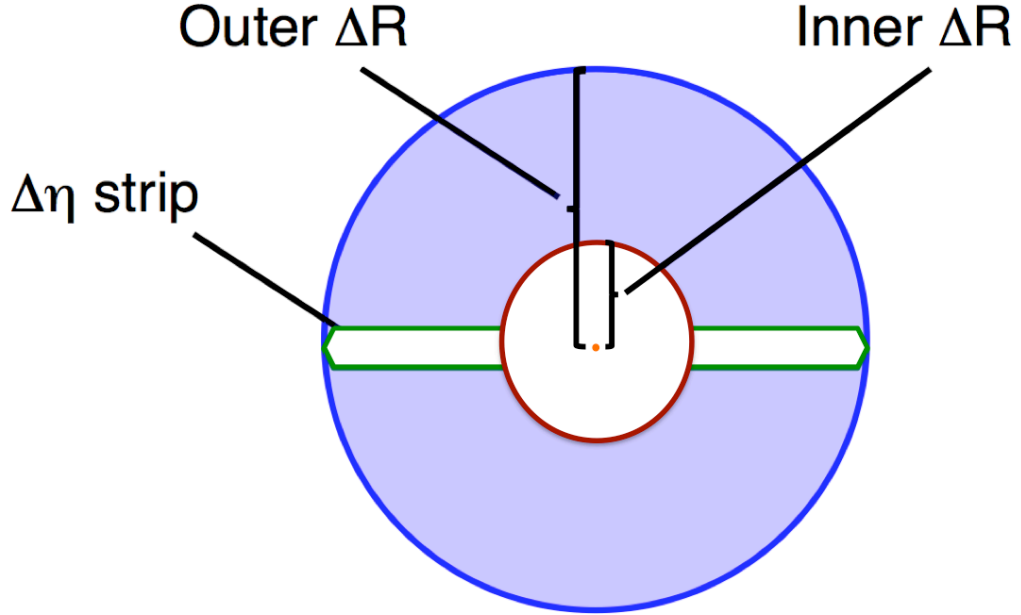

Figure 5.2: A schematic of the isolation area for tracker and ECAL isolations. The blue shaded area shows the region included in the sums. Tracks or hits in the white area are subtracted from the total.

The selection cuts used for this analysis are listed in Table 5.5. The requirement on the pixel seed is not applied to allow for increased efficiency in our search. Further details about the effect of this cut can be found in Section A.2.

Table 5.5: Tight photon selection cuts used in the e^* analysis.

Photon identification variable	Cut threshold
$ \eta $	< 1.4442
E_T	$> 20. \text{ GeV}/c$
H/E	< 0.05
Tracker Isolation	$< 2.0 + 0.001 \cdot E_T$
ECAL Isolation	$< 4.2 + 0.006 \cdot E_T$
HCAL Isolation	$< 2.2 + 0.0025 \cdot E_T$
$\sigma_{i\eta i\eta}$	0.013
hasPixelSeed	No Requirement

Photon Efficiency Measurement

The electron and photon efficiencies can be measured from the data using the tag and probe method at the Z mass ($91 \text{ GeV}/c^2$). The Z has a well known mass and decays to two electrons with a relatively high cross section. In $Z \rightarrow ee$ events, one expects to find two good electrons (which can be treated as photons by substituting photon identification criteria). The idea then is to find these events by selecting one well-identified electron (tag) and then pairing it with a “denominator” object (probe) with much looser identification requirements. If the invariant mass of the tag and the probe is near the Z mass, then it is quite likely you have found a $Z \rightarrow ee$ event. One can now subject the probe to the selection criteria of interest to compute the efficiency of the selection.

In the tag and probe method for photons a very high quality electron is selected; this is the “tag” leg. Next superclusters are paired with the tag electron and if the mass is within $50 \text{ GeV}/c^2 < Z < 120 \text{ GeV}/c^2$, the event is accepted as a denominator. The supercluster is then subjected to the tight photon identification selection. In order to minimize background, the photon candidate (super cluster) is also required to have a matching pixel seed in the inner detector. If the supercluster passes the requirements, this event is counted in the numerator. Here the numerator is a subset of the denominator. The efficiency is then the numerator divided by the denominator. The efficiency, ϵ is the given by the number of passing probe events divided by the number of passing probes plus failing probes:

$$\epsilon = \frac{N_{TT} + N_{TP}}{N_{TT} + N_{TP} + N_{TF}} \quad (5.2)$$

where N_{TT} are events with two objects passing the tag criteria, N_{TP} are events with one passing the tag criteria and one passing the probe criteria, and N_{TF} are events where one object passes the tag criteria, but no passing probes are found. Events with more than one tag-tag or tag-probe pair are rejected. Only unique tag-probe pairs are counted. MC is used to estimate the background contamination.

This measurement is done predominantly with clusters of E_T less than 60 GeV. The E_T spectrum of the photons for the e^* signal is significantly harder than this (Figure 5.5), but the identification efficiency has been shown to be fairly flat in

E_T and we do not correct for any E_T dependence. The measured efficiency for this selection in data is 87.97 ± 0.38 (statistical) $\pm 0.94\%$ (systematic). The only correction applied in the e^* analysis is to scale the MC backgrounds with real photons by the factor 0.967 ± 0.012 to account for the difference in the efficiency measured in data versus MC [66]. This adjustment is reflected in the final efficiencies quoted in Chapter 7.2 and in Tables 5.7 and 5.8.

5.3.2 Electron Identification

This analysis uses an electron selection dedicated to high efficiency at high energies ($p_T > 25$ GeV) called the High Energy Electron Positron (HEEP) selection[65]. The selection is defined differently in the ECAL barrel and endcaps, and the gap from $|\eta| = 1.4442$ to $|\eta| = 1.566$ is excluded. All the electrons selected are ECAL driven, meaning they are constructed starting from an electromagnetic cluster in the ECAL, rather than from a track.

The cuts are detailed in Table 5.6. Some ECAL variables, H/E and $\sigma_{i\eta i\eta}$, are defined here as they are for the photon (Section 5.3.1). There are further variables concerning the electron's track and different isolations used to identify HEEP electrons.

- $|\Delta\phi(vtx)|$: The difference between the ϕ position of the supercluster and the ϕ position as extrapolated from the position of the hit in the innermost layer of the tracker and the vertex position.
- $|\Delta\eta(vtx)|$: The difference between the η position of the supercluster and the η position as extrapolated from the position of the hit in the innermost layer of the tracker and the vertex position.
- E_{2x5}/E_{5x5} : The sum of energy of the two highest energy hits in the supercluster and the energy in the 5×5 array surrounding the most energetic hit.
- EM + Had depth 1: EM here is the ECAL isolation energy defined similarly to the ECAL isolation for the photon, but using an outer cone of radius 0.3 instead of 0.4; Had depth 1 is the sum of transverse energy in a cone of radius

> 0.15 and < 0.3 in all depths of the hadronic calorimeter towers 1-17, depth 1 only of towers 18-29 and depth 2 for towers 27-29.

- Had depth 2: The sum of transverse energy in a cone of radius > 0.15 and < 0.3 in depth 2 of towers 18-26 and depth 3 of 27-29.
- Track Isolation: The sum of the p_T of all tracks in a cone of $\Delta R = 0.3$ about the line from the reconstructed primary vertex to the electron's cluster position *minus* the p_T of tracks in an inner cone of 0.04 and an η strip of 0.015 (Figure 5.2). Tracks with $d_{xy} > 9999$. or $d_z > 0.2$ cm are also excluded from the sum.

As is the case for photons, the isolations here are very useful in controlling the background from jets. The p_T dependence allows for tight isolation requirements while avoiding large losses of efficiency with increasing electron energies. The $|\Delta\eta(vtx)|$ and $|\Delta\phi(vtx)|$ matching requirements ensure the track and cluster are from the same object rather than two non-electron objects that just happen to overlap. E_{2x5}/E_{5x5} is another measure of the cluster shape and also suppresses jet backgrounds.

The laser corrections were not applied in the data sample used for this analysis, and a shift was observed in the mass of the Z when the electrons from the Z impacted the EE. To correct for this, an energy shift of 4% is applied to HEEP electrons in the endcap. No correction is necessary in the barrel. The mass spectrum for all dielectron selected events is shown in Figure 5.3. The QCD background is estimated from data (see Section 5.5.2) and the other backgrounds come from MC. We see good agreement between the MC spectrum and the one observed in data.

Electron Efficiency Measurement

The efficiency for an electron to be reconstructed and included in the standard electron collection was measured to be $98.6\% \pm 0.5\%$ in the barrel and $96.2\% \pm 0.8\%$ in the endcaps by the electroweak group in [67] using the tag and probe method. The ratios of the efficiency measured in the data to the efficiency

Table 5.6: HEEP electron election

Variable	Barrel Cut	Endcap Cut
E_T	$> 25 \text{ GeV}/c$	$> 25 \text{ GeV}/c$
$ \eta_{sc} $	< 1.4442	(1.560, 2.5)
EcalDriven	True	True
H/E	< 0.05	< 0.05
$ \Delta\phi(vtx) $	< 0.09	< 0.09
$ \Delta\eta(vtx) $	< 0.005	< 0.007
$\sigma_{i\eta i\eta}$	n/a	< 0.03
E_{2x5}/E_{5x5}	$> 0.94 \parallel E_{1x5}/E_{5x5} > 0.83$	n/a
EM + Had depth 1	$< 2.0 + 0.03 \cdot E_T$	$< 2.5(E_T < 50)$; else $< 2.5 + 0.03 \cdot (E_T/50)$
Had depth 2	n/a	< 0.5
Track Isolation	< 7.5	$< 15.$

measured in MC scale factors are very close to 1 (1.001 ± 0.005 in the barrel and 0.999 ± 0.009 in the endcap), and therefore we do not apply a correction for this in the analysis.

The tag and probe method is also used to extract the HEEP electron efficiency from data [65]. Again, this is used to determine the difference in efficiency between data and the MC, but the difference is larger. Therefore, this ratio is applied to the electrons in our MC samples to more accurately estimate our projected yields. Scale factors to correct for the difference in efficiency measured in data and MC are applied separately for EB and EE electrons. The factor is 0.978 ± 0.004 in the barrel and 0.994 ± 0.006 in the endcap. This adjustment is reflected in the final efficiencies quoted in Chapter 7.2 and in Tables 5.7 and 5.8. The efficiency as a function of p_T is flat above $45 \text{ GeV}/c$ which is very useful for this analysis where most of the signal electrons have a $p_T > 45 \text{ GeV}/c$.

5.4 Event Selection

The data is first skimmed using the official CMS two-electron Exotica High p_T Electron (HPTE) skim. To pass the skim the event must have at least two reconstructed electrons with $p_T > 15 \text{ GeV}/c$ and $H/E < 0.1$. The Swiss-cross

spike cleaning was applied during the official data processing. Offline, we reject electrons and photons whose supercluster fails the $E2/E9 < 0.95$ non-isolated spike cut [58].

After skimming, the events are first required to contain two electrons passing the HEEP selection criteria (Section 5.3.2). Next, one photon *not* sharing its supercluster with either electron and passing the tight photon identification is required (Section 5.3.1). The optional requirement on the pixel match variable is not used, and the photon is further constrained to have an $E_T > 20$ GeV/ c , and fall within $|\eta| < 1.4442$. There is a loss of signal efficiency of ranging between 6.1% and 8.4% due to the disuse of EE photons. The effect of not using endcap photons is further explored in Section A.3. The selected photon must also have a ΔR separation > 0.5 to the electrons. This is to avoid any complication due to overlapping isolation regions.

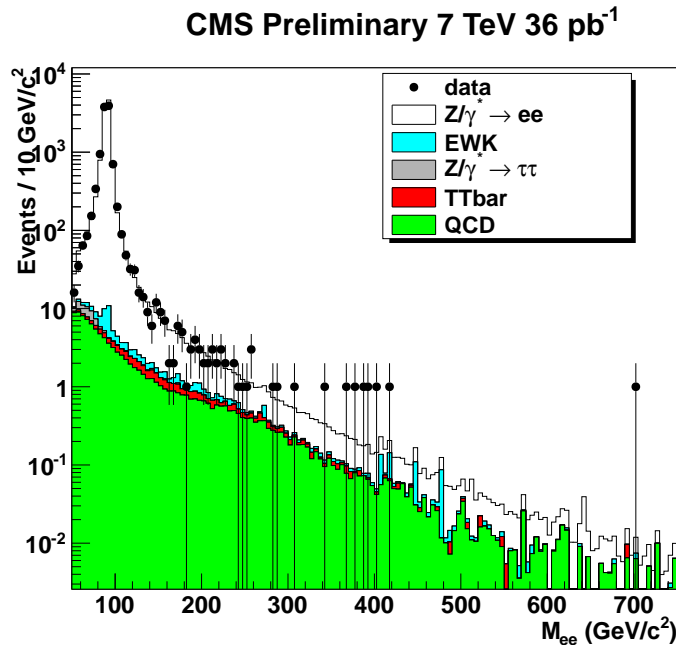

Figure 5.3: Di-electron mass spectrum with QCD background estimated from data.

In events where more than two electrons pass the HEEP electron selection or more than one photon passes tight identification, the highest p_T (E_T) objects are selected. This has a negligible effect on the signal efficiency. The electrons are

selected before the photons, and the photons are not allowed to share a supercluster with either of the selected electrons. The photons are not, however, removed if they share a supercluster with a non-selected electron.

The invariant mass of the two selected electrons is required to be greater than $60 \text{ GeV}/c^2$ to avoid the edge effect of using a $Z\gamma$ MC sample with an \hat{s} cut at 20 GeV . This does not negatively affect our signal efficiency. Table 5.7 shows the results of these event selection criteria on data and background MCs. The signal results and efficiencies are shown in Table 5.8. Another cut that was considered was to remove all events where any combination of selected objects gave an invariant mass consistent with the Z mass ($[80,100] \text{ GeV}/c^2$). The small effect of this cut on the reach of the analysis is briefly explored in Section A.1. For the final results, this cut was not used.

Figure 5.5 shows the E_T spectrum of the highest E_T photon in events passing the full event selection. The red shows the data-driven estimate of the contribution of misidentified photons from jets, the details of which will be discussed in Section 5.5.2. The di-electron mass spectrum after full event selection can be seen in Figure 5.4.

Table 5.7: Data and MC background event selection results for $\int L = 36 \text{ pb}^{-1}$. In the MC determined backgrounds, the photon and electrons are required to match with $\Delta R < 0.1$ to generator level photons or electrons for rows “2 HEEP e ” and beyond.

Cut	Data Events	Simulated Background Events			
		$Z/\gamma^* \rightarrow ee\gamma$	EWK	$t\bar{t}$	$\gamma\gamma$
HPTE Skim	753532	546.3	1603	92.7	18.02
Pass JSON, Vtx, Scraping	649309	545.8	1601	92.7	17.91
2 HEEP e	10631	445.2	28.4	24.0	0.0
Pass HLT	10385	445.2	28.4	24.0	0.0
1 Tight γ	9	11.71	0.36	0.06	0.0
$M_{ee} > 60 \text{ GeV}/c^2$	7	10.57	0.34	0.05	0.0

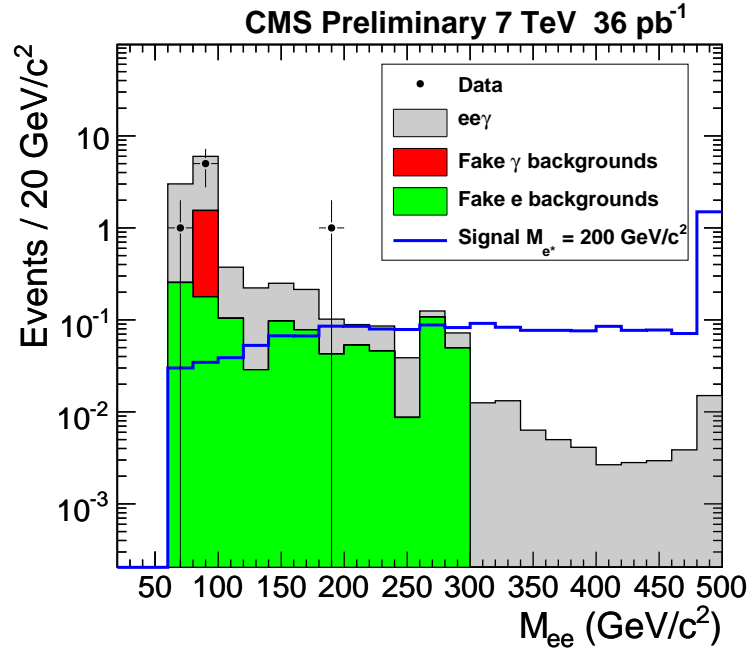

Figure 5.4: Di-electron mass spectrum for events passing the full selection. The signal shown here is $M_{e^*} = 200 \text{ GeV}/c^2$.

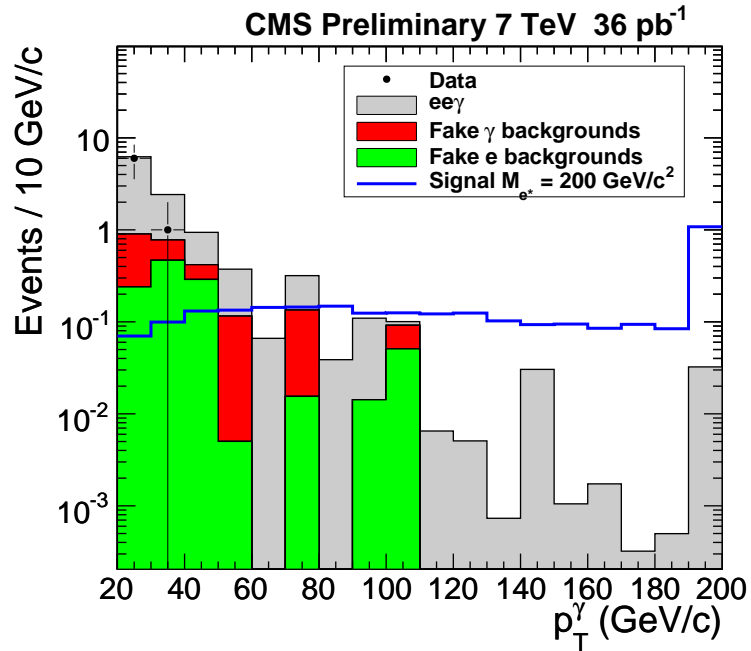

Figure 5.5: E_T of photons passing full event selection. No cut on the $e\gamma$ invariant mass is applied. The signal shown here is $M_{e^*} = 200 \text{ GeV}/c^2$.

Table 5.8: Signal results and efficiencies scaled to $\int L = 36 \text{ pb}^{-1}$ for $\Lambda = 4 \text{ TeV}$.

Cut	Passing Events (Efficiency to Previous Cut)					
	$M_{e^*}=200 \text{ GeV}/c^2$	400 GeV/c^2	600 GeV/c^2	800 GeV/c^2	1000 GeV/c^2	
Total Events	7.12	2.92	1.33	0.60	0.27	
HPTE Skim	5.97 (83.8%)	2.53 (86.7%)	1.17 (88.1%)	0.54 (89.2 %)	0.24 (90.4%)	
Scraping and Vtx Filters	5.96 (99.9%)	2.53 (99.8%)	1.17 (99.9%)	0.54 (99.9%)	0.24 (99.9%)	
2 HEEP e	4.54 (76.3%)	1.97 (78.0%)	0.93 (79.1%)	0.42 (78.9%)	0.19 (79.0%)	
1 Tight γ	2.79 (61.4%)	1.32 (67.1%)	0.64 (68.6%)	0.30 (70.8%)	0.14 (72.0%)	
$M_{ee} > 60 \text{ GeV}/c^2$	2.77 (99.3%)	1.32 (99.7%)	0.64 (99.9%)	0.30 (99.9%)	0.14 (100%)	
Total	2.77 (38.9%)	1.32 (45.2%)	0.64 (47.7%)	0.30 (49.7%)	0.14 (51.3%)	

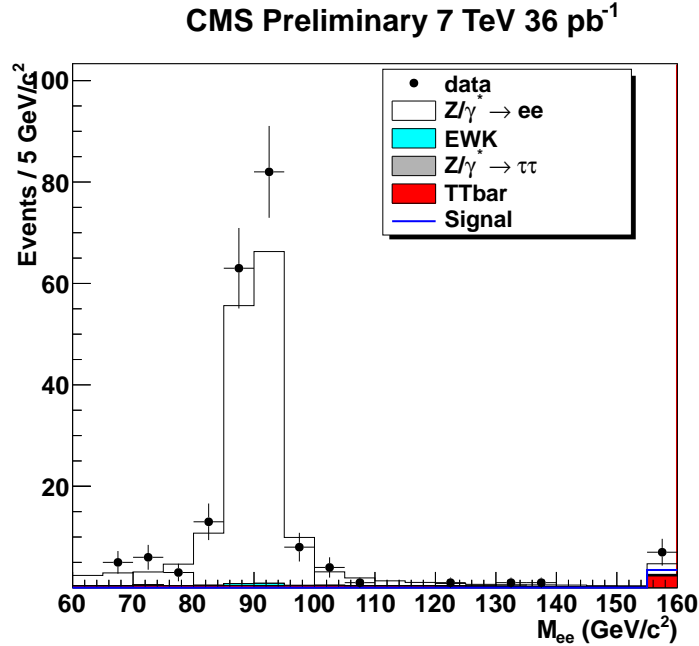

Figure 5.6: Di-electron mass spectrum for events with an ultra-loose photon. Signal is $M_{e^*} = 200 \text{ GeV}/c^2$.

5.5 Backgrounds

5.5.1 Irreducible Standard Model Backgrounds

The main backgrounds to this analysis are the ones that have two real electrons and a real photon. The biggest contribution comes from $Z/\gamma^* \rightarrow ee\gamma$. There are also contributions from $t\bar{t}$, WW , WZ , and ZZ . These backgrounds are mainly controlled by the high E_T thresholds on the electrons and photon and the tight identification requirements. The expected contribution to the background yield from these types of events is taken from MC. The reconstructed electrons and photon must match to a generated photon or electron.

$Z\gamma$

The Z boson is produced with a high cross section and decays about 3.4% of the time to a pair of oppositely charged leptons. The cross section for $Z/\gamma^* \rightarrow ee$ is about 1670 pb^{-1} . If a photon is radiated either in the initial (ISR) or final

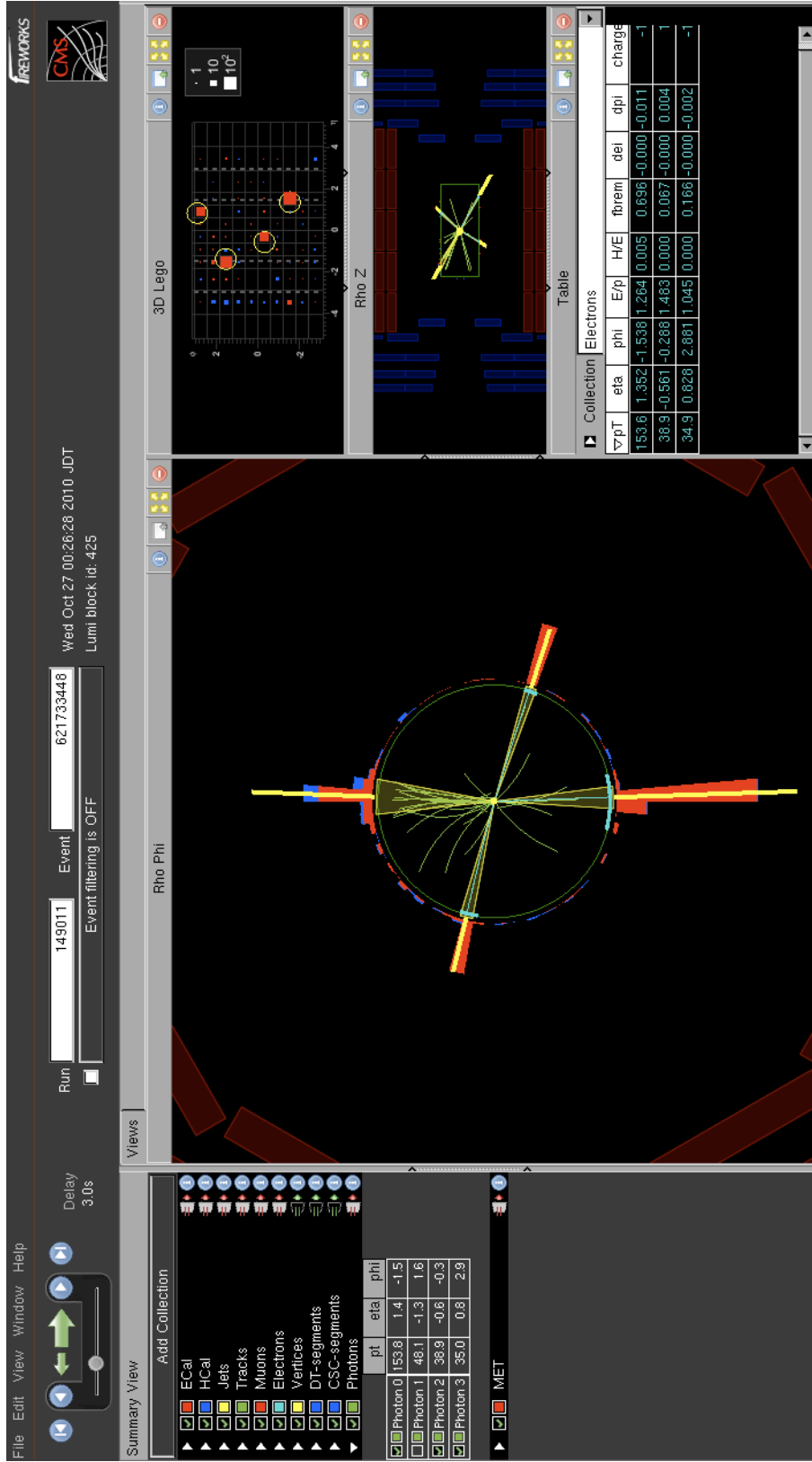

Figure 5.7: Event display for the highest M_{ee} event passing the full event selection. $M_{ee} = 194 \text{ GeV}/c^2$; $M_{e\gamma}^{Max} = 123 \text{ GeV}/c^2$; $M_{e\gamma}^{Min} = 92 \text{ GeV}/c^2$; $M_{e\gamma} = 248 \text{ GeV}/c^2$. Here the object identified as the photon is actually an electron.

(FSR) state, the event has the exact signature of the e^* final state: two electrons and a photon. The vast majority of the time these events will not have a high enough $e\gamma$ invariant mass to be confused with the signal.

Diboson Backgrounds

Events with W s and Z s can produce two prompt electrons which can radiate photons (ZZ , WW , WZ), or can produce three electrons and the third electron can be identified as a photon (WZ), or produce four leptons with one identified as a photon (ZZ). These backgrounds contribute far less than $Z\gamma$ due to their much smaller cross section times branching ratios. We expect only about a third of an event from diboson processes to pass event selection for our integrated luminosity of 36 pb^{-1} .

$t\bar{t}$

Top quarks decay with very high probability to a b quark and a W . If both W s in a $t\bar{t}$ event decay to an electron and one electron emits a hard photon we again find our two electrons and one photon in the final state. Though not a large contributor, we do find some MC $t\bar{t}$ events passing our final selection. We expect less than a tenth of an event from $t\bar{t}$ to pass event selection for our integrated luminosity of 36 pb^{-1} .

Diphoton Backgrounds

There are two processes that produce prompt diphotons, the Born and Box processes. These produce irreducible backgrounds when one of the photons converts producing an electron–positron pair. If the electron and positron are both well reconstructed, along with the remaining original prompt photon, we again have our desired final state. The contribution from this background was estimated from MC and found to be negligible (0 events passing).

5.5.2 Reducible Backgrounds

A more complicated approach must be taken to understand the backgrounds with misidentified objects. Data-driven techniques are used to understand the contributions from these sources.

Photon Fakes

There are processes within Standard Model which can give rise to events with two real electrons and a jet that is reconstructed as a photon. The largest contribution to this process is $Z/\gamma^* \rightarrow ee + \text{jets}$. A jet may hadronize into a leading π^0 that decays into two photons which, at high E_T , are reconstructed as a single photon. While this type of fluctuation may not happen with high probability for any given jet, there is a huge complement of jets making it an important background to this study. Shower shape variables and isolation variables are sensitive to the differences between real photons and photons coming from hadron decays.

When a jet or non-prompt photon passes our photon selection, we call it a “fake”. Photons directly produced in the hard interaction, from prompt decays or radiated from leptons or quarks are considered “real” photons. We are interested in estimating the rate of jets faking an isolated photon. This rate depends on the details of hadronization which we do not expect to be simulated well enough in MC, so we use a data-driven approach.

This measurement was made using three differently triggered samples and three different purity estimation techniques for a total of four semi-independent measurements. The differences in the results was used to determine one component of the systematic uncertainty.

The fake rate is defined as follows:

$$\epsilon_{fake}^{raw} = \frac{N(tight)}{N(loose, flipped\ isolation)} \quad (5.3)$$

The tight photon cuts used for the numerator are identical to those used for the full photon identification and loose photon identification with “flipped” isolation

is defined in Tables 5.9 and 5.10. The denominator is required to pass the loose selection *and* the flipped isolation cuts.

Table 5.9: Loose selection cuts for denominator

Photon Variable	Cut Threshold
H/E	< 0.05
Tracker Isolation	$< \text{Min}(5 \cdot (3.5 + 0.001 \cdot E_T), 0.2 \cdot E_T)$
ECAL Isolation	$< \text{Min}(5 \cdot (4.2 + 0.006 \cdot E_T), 0.2 \cdot E_T)$
HCAL Isolation	$< \text{Min}(5 \cdot (2.2 + 0.0025 \cdot E_T), 0.2 \cdot E_T)$
$ \eta $	< 1.4442

Table 5.10: Flipped selection cuts for denominator is the 'OR' of all the cuts

Photon Variable	Cut Threshold
Tracker Isolation	$> (3.5 + 0.001 \cdot E_T)$
ECAL Isolation	$> (4.2 + 0.006 \cdot E_T)$
HCAL Isolation	$> (2.2 + 0.0025 \cdot E_T)$
$\sigma_{i\eta i\eta}$	> 0.013

The loose selection cuts for the denominator are selected in this way to avoid problems with the jet energy scale. They ensure that very non-isolated photons do not enter the denominator while keeping the real photon contamination low and allowing for a reasonable sample size of denominator events.

After the tight selection, the numerator is contaminated with prompt photons even in jet dominated samples. To determine the amount of contamination three template methods were considered: the isolation method, the conversion method and the $\sigma_{i\eta i\eta}$ template method. In the $\sigma_{i\eta i\eta}$ template method, a background template and a signal template (of prompt photons) are given as an input to TFractionFitter class of ROOT which fits the data using the maximum log likelihood technique. The TFractionFitter class then reports the fraction of photons in the data sample. This contamination of real photons is then corrected for to give the true photon fake rate.

The fake rate vs p_T is determined for four different combinations of trigger sample and template method and an exponential fit as a function of p_T is then

performed on the combination of the four measurements. The resulting function is used to determine the number of events with fake photons we expect in our final selection. The ratio of each measurement to the fit result is also calculated to estimate the systematic uncertainty on the fake rate [68].

To apply the fake rate to data we first perform the entire analysis, but release the cuts on the photon selection to those described as the denominator in the previous section (loose identification with flipped isolation). Using the same two-electron skim as used for the full analysis, we select events with two HEEP electrons. The two selected HEEP electrons are required to satisfy $M_{ee} > 60$. Every photon that passes the denominator cuts is selected, so we may have more than one contribution per event. The events passing this full selection are then weighted according to the fit result.

Using this data-driven technique we estimate the contribution from events with fake photons in our analysis to be 0.10 for the lowest mass hypothesis, 200 GeV/ c^2 , and 0.00 for the higher masses.

Electron Fakes

Backgrounds with only one or no real electrons can contribute when jets in the events fake electrons. The biggest contributions come from backgrounds such as $W \rightarrow e\nu + \gamma$ where there is also a jet in the event faking an electron. This may happen when the jet fluctuates to be largely electromagnetic, as in the photon case, but there is also a well-matching track in the tracker.

We use the fake rates computed for HEEP electrons in [65]. The HEEP fake rate denominator is a super cluster with $H/E < 0.05$ and $p_T > 20$ GeV/ c . The numerator is the fully-selected HEEP electron. The fake rate is computed as a function of p_T separately in the barrel and in two η bins in the endcap split at $|\eta| = 2.0$. The fake rate runs out of statistics at high p_T , but we did not find any candidates beyond the measured p_T range.

To apply this fake rate in our analysis we start with a sample skimmed for two photons > 20 GeV/ c E_T with $H/E < 0.05$. In this sample we then select events with one HEEP electron and one photon passing tight identification. The rest of

the super clusters in the event with $H/E < 0.05$ are then denominator objects.

We only consider superclusters which are *not* matched to a good HEEP electron to remove the substantial contribution from real Z s. The removal of HEEP electrons can also remove those jets which pass the HEEP selection, so this must be corrected for. Taking 'F' to be the fake rate, $F \times$ (the total number of jets) is the number of jets which are improperly removed. So the total number of jets remaining in selected sample is $(1-F) \times$ (the number of jets). To get back to the correct estimate of the fake background, we apply a modified fake rate to the selected events, $F/(1-F)$, that takes the HEEP electron removal into account.

Events satisfying the mass cut $M(\text{HEEP electron, super cluster}) > 60 \text{ GeV}/c^2$ are selected. The same HLT used for the signal analysis is applied. The selected events are then weighted according to their p_T and η , giving the estimate of the number of events with one fake electron we expect in the analysis.

Multiple Fake Backgrounds

The contributions from events with two or more fakes can also be determined in a similar fashion to the preceding descriptions. The rates from events with one real photon and two fake electrons and events from events with three fake objects is also estimated from data. These contributions are subtracted from the one fake electron estimate since they are already accounted for by the fake photon contribution. Taking into account this correction, the estimated contribution of events with a fake electron is 0.20 events for the lowest e^* mass region and 0.00 for the higher masses.

5.5.3 Control Regions

As the signal selection is very tight (yielding only 7 events before the final cut), it is difficult to assess the agreement between our findings and the estimates from MC and the data-driven techniques. To better illustrate the validity of these predictions three different checks were made. The control regions chosen all have at least one electron and one photon to stay somewhat close to our desired final state.

Photon Selection Variables

The first control region we chose to look at are the photon identification variables when after releasing nearly all of the cuts on the selected photon. In Figures 5.6 and 5.8, various distributions for events with two HEEP electrons plus an “ultra loose” photon are shown. This photon is simply required to have $E_T > 20 \text{ GeV}/c$, $|\eta| < 1.4442$, and not share its super cluster with the selected electrons. This leaves us with a fairly clean sample of $Z \rightarrow ee + \gamma$ events, as we expect it would. The shapes of the identification variable distributions are well-reproduced in the MC. No jet backgrounds were included, and this presumably accounts for much of the normalization difference. The main check here is that the identification and isolation variables are similar in data and MC.

Loosened Photon

The second check is to release two of the photon isolation requirements and remeasure the photon fake rate as described in Section 5.5.2 with the numerator and denominator in Table 5.11. The ECAL and Tracker isolations were released to get at least a doubling of events without straying as far as the “ultra loose” does from our tight identification.

Table 5.11: Loosened Photon Selection

Photon Variable	Numerator Cut	Denominator Cut
H/E	< 0.05	< 0.05
HCAL Isolation	$< 2.2 + 0.0025 \cdot E_T$	$< \text{Min}\{5(2.2 + 0.0025 \cdot E_T), 0.2E_T\}$
$\sigma_{in\eta}$	< 0.0105	> 0.0105
$ \eta $	< 1.4442	< 1.4442
hasPixelSeed	no requirement	no requirement

This loosened photon selection yields 16 data events with 2 HEEP electrons and the modified photon. We find good agreement between data and the prediction from the modified fake rate. This gives us a greater confidence in our prediction of the fake photon estimation procedure and of the overall event selection prediction. Figures 5.9 and 5.10 illustrate the agreement in the maximum $e\gamma$ invariant mass and photon E_T spectra.

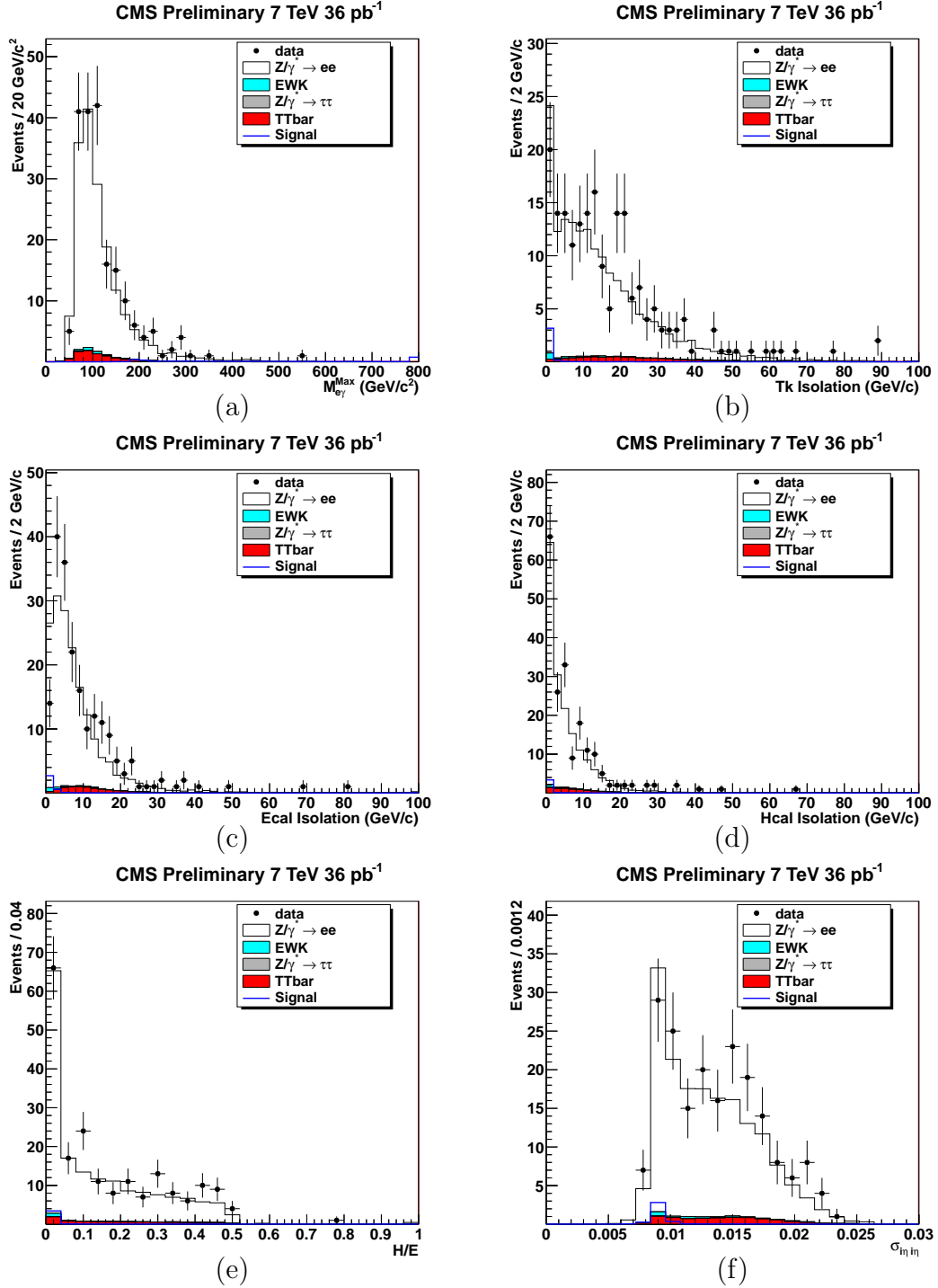

Figure 5.8: Maximum $e\gamma$ mass (a) in events with an ultra-loose photon along with all the identification variables, Tracker Isolation (b), Ecal Isolation (c), Hcal Isolation (d), H/E (e), and $\sigma_{in\eta}$ (f) used for tight photon identification. The distributions compare data with Monte Carlo backgrounds. Signal is $M_{e^*} = 200$ GeV/c².

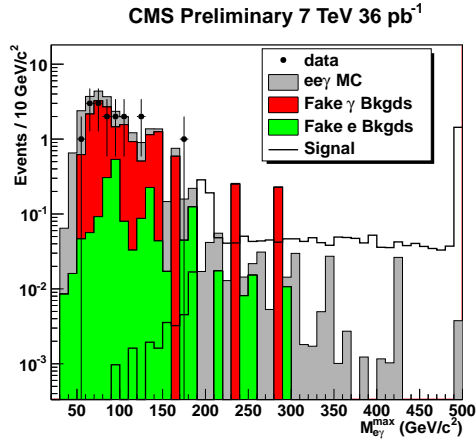

Figure 5.9: Maximum $e\gamma$ mass for events with loosened photon selection. The signal is $M_{e^*} = 200 \text{ GeV}/c^2$.

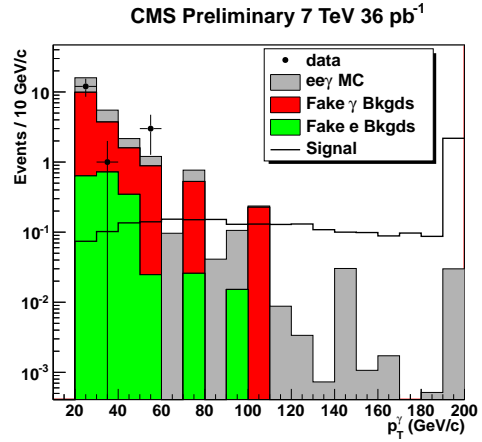

Figure 5.10: Photon E_T spectrum with loosened photon selection. The signal is $M_{e^*} = 200 \text{ GeV}/c^2$.

$e\gamma$ Spectrum

A final check was made by requiring only one HEEP electron and one tight photon in the event. Without the pixel veto this check would mainly select $Z \rightarrow ee$ events since good electrons from the Z also pass the isolation and shower shape requirements of the tight photon with a high efficiency. To remove most of this contamination and focus on the estimations of the photon and electron fake rates, the pixel veto was reinstated and the photon fake rate remeasured. The skim for this check was changed from the HPTE skim which requires two electrons and is too tight to a skim requiring two photons with $E_T > 20 \text{ GeV}/c$ and either a HEEP electron or a tight photon.

This comparison was done in two ways. First we applied the fake rate to data events as is done in the standard analysis (Figures 5.11, 5.13, 5.15). We also applied the fake rate on the MC backgrounds (Figures 5.12, 5.14, 5.16). The two methods show good agreement both with the data and with each other. The error bands show only the estimated systematic errors assigned to the fake rates which are 20% for the photon fakes, 25% for barrel electrons, and 40% for endcap electrons, and are therefore somewhat of an underestimate. Good agreement here further increases our confidence in the predictions of both the electron and photon fake rates since they are major contributors to this event selection.

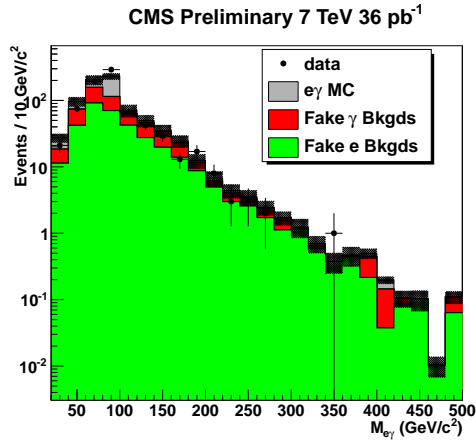

Figure 5.11: $e\gamma$ invariant mass spectrum. Fake rate applied to data.

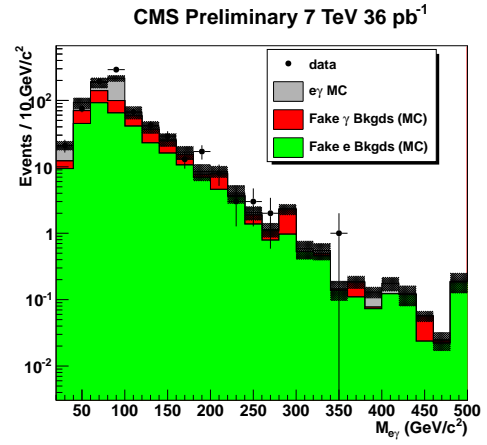

Figure 5.12: $e\gamma$ invariant mass spectrum. Fake rate applied to MC.

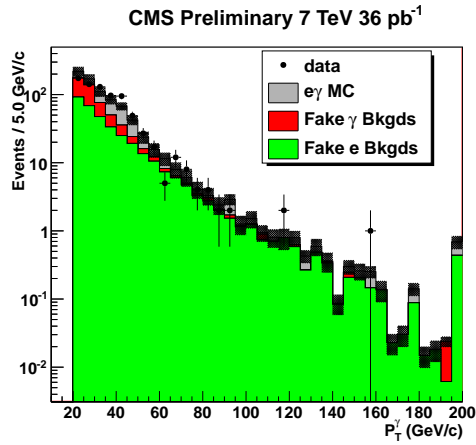

Figure 5.13: Photon E_T spectrum in $e\gamma$ events. Fake rate applied to data.

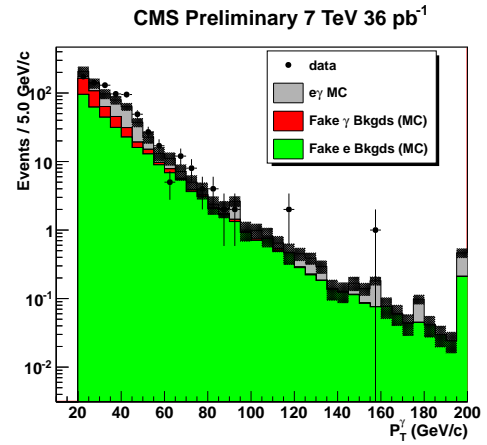

Figure 5.14: Photon E_T spectrum in $e\gamma$ events. Fake rate applied to MC.

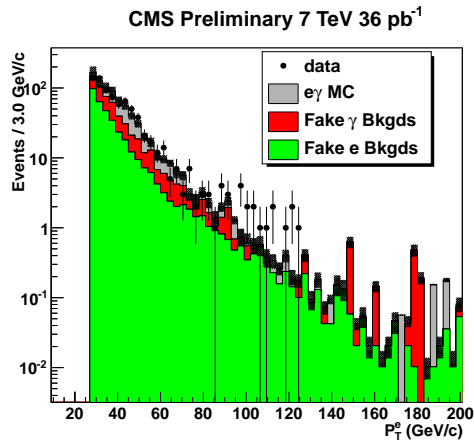

Figure 5.15: Electron p_T spectrum in $e\gamma$ events. Fake rate applied to data.

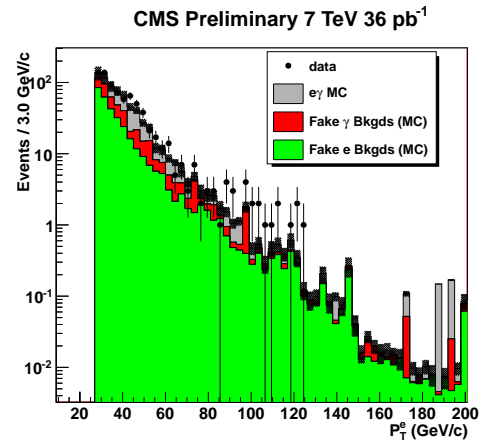

Figure 5.16: Electron p_T spectrum in $e\gamma$ events. Fake rate applied to MC.

Chapter 6

Systematic Uncertainties

Various systematic effects must be evaluated to properly understand the results of this study. There are many sources of systematic error, but we limit ourselves to those with the greatest effect and the ones most important from a physics standpoint. In the following we will discuss five sources of systematic error: the ECAL energy scale, the integrated luminosity of the data sample, uncertainties on the data-driven background estimates, theoretical errors on the cross sections and parton distribution functions (PDFs) for the main backgrounds, and the effect of a simplification in the angular distribution of the signal simulation.

6.1 ECAL Energy Scale

As discussed in Chapter 3.8, the ECAL is precisely calibrated in a variety of ways. The precision of the calibration depends somewhat on the collected luminosity. The inter-calibration techniques can be used to get a high precision calibration with very little integrated luminosity. However, this only gives us information about the response of one crystal versus another, and no information about the absolute response of the crystals. For this we need to use calibrations based on physics processes such as $Z \rightarrow ee$. At this time, we do not have enough events of this type to calibrate the ECAL to the design specifications.

To account for this uncertainty, a conservative estimate of the potential error is taken to be -1% in the barrel and -4% in the endcaps. The barrel error

is taken from the measured π^0 mass shift (see Section 3.4.1), while the endcap correction is from the Z mass shift. The whole analysis is repeated with these shifts applied to the photon and electron energies. The effect of this is approximately 0.1% in the signal efficiency and a change of 1.6% in the total number of expected background events.

6.2 Luminosity

At CMS the luminosity collected by the experiment is determined using the forward hadronic calorimeter (HF) with great statistical accuracy. It cannot, however, provide an absolute measure of the luminosity. For this measurement, dedicated Van de Meers scans were carried out in October of 2010.

These scans use the interaction rate as a function of beam separation combined with the known beam current to determine the absolute luminosity scale. In the relation:

$$\mathcal{L} = \frac{N_1 N_2 f}{2\pi\sigma_x\sigma_y} \quad (6.1)$$

the scans determine σ_x and σ_y , the number of protons in the beams is given by N_1 and N_2 , and f is the collision frequency. Both the HF and the number of vertices reconstructed in the tracker are used to compute effective beam size. The total systematic error on this measurement is found to be 4% [69]. This 4% is used for the final calculation of the limits.

6.3 Data Driven Estimate Uncertainties

Electron Fake Rate Errors

The electron fake rate systematic error is derived by taking two samples of events; one with a good HEEP electron and a denominator supercluster and the other with two denominator superclusters. The events are weighted by the fake rate discussed in Section 5.5.2. The first sample has a large contribution from $Z/\gamma^* \rightarrow ee$ events and also includes the process W +jets. The second sample does not include these contributions, and these differences are removed using MC

estimates. The remaining difference in the fake rate estimate is 25% in the barrel and 40% in the endcap, and these are taken as the systematic errors on the fake rate.

Photon Fake Rate Errors

The photon fake rate systematic error has two components. The first component comes from the variation in the result from the four different determinations of the photon fake rate and is taken as a constant 20% error (Section 5.5.2).

The second component comes from the differences between the sample where the fake rate is measured versus where it is applied. The measurement of this fake rate was done on jet-triggered, muon-triggered, and photon-triggered samples. The fake rate is being used to estimate the rate of the Z +jets background. This error is estimated from MC and is found to have a strong p_T dependence.

6.4 Theoretical Errors

When modeling the backgrounds certain choices of parameters must be made to best replicate the extremely complicated physics that actually takes place during proton-proton collisions. One of the most important parameterizations is of the PDFs. These functions describe the distribution of the momentum fractions of the partons in the colliding protons. For the MC samples used in this analysis the set of PDFs used are CTEQ6L [55] and their related error functions. The error sets were used to estimate the systematic uncertainties using the re-weighting method. Furthermore, the renormalization scale uncertainty was estimated by varying it from half to twice the standard value. The combined effect from the PDF and renormalization scale on the acceptance times efficiency of the background yield estimate is about 5%.

PDF uncertainties and the effect of the factorization and renormalization scales on the signal are not taken into account.

6.5 Signal Modeling Error

The PYTHIA generator is used to make the signal MC samples, but it is known that the angular distribution of the e^* is not properly modeled. Another generator, compHEP[70], contains a more accurate treatment of the angular decay and a generator level check of the effect on the acceptance was made. The result was a very small effect and was therefore disregarded.

The relative size of the errors on the signal and backgrounds are quoted in Table 6.1.

Table 6.1: Systematic errors included in limit setting and the size of the effect for $M_{e^*}=200$ GeV/ c^2 . The total error given at the bottom is calculated by adding relative errors in the column in quadrature.

Source	Magnitude	$e^*(M=200)$
Luminosity	$\pm 4\%$	0%
Energy Scale	-1.3% (EB), -4.1% (EE)	-0.05%
Photon Fake Rate	$\pm 20.0\%$ + additional	0%
Electron Fake Rate	25% (EB), 40% (EE)	0%
Photon ID	$\pm 2.5\%$	$\pm 2.5\%$
Electron ID	$\pm 0.6\%$ (EB), 1.1% (EE)	$\pm 1.68\%$
Signal Modeling (not incl.)	-0.03%	-0.01%
Total	-	3.01%

Chapter 7

Results

After the event selection described in Chapter 5.5.3, the reconstructed invariant mass of each $e\gamma$ pair is computed and the higher mass combination is selected as the final analysis variable. This choice is made to maximize the efficiency of selecting excited electron events, and does not attempt to reconstruct actual e^* resonance with any priority. The $e\gamma$ maximum invariant mass distribution is then used to perform a Bayesian counting experiment to set limits on the production cross section of excited electrons.

7.1 $e\gamma$ Pair Selection and Final Cut

As the final state for this search consists of two electrons and one photon, there remains an ambiguity in choosing the $e\gamma$ pair that should reconstruct to the excited electron mass. For the lowest masses the choice of the lower $e\gamma$ invariant mass more often gives the correct e^* mass. However, this starts to change even at e^* masses as low as $400 \text{ GeV}/c^2$.

For the final step of the analysis, we choose to perform a counting experiment. We simply want to obtain the largest possible signal event yield without considering how often we choose the correct $e\gamma$ pair (meaning the pair where the electron and photon are from the decay of the e^*). For this reason, we will choose the highest invariant mass pair. The distributions for the two choices can be seen in Figures 7.1 and 7.2.

A one-sided cut on the invariant mass is applied and yields a signal efficiency of about 99% for that cut after all others have been applied. For a signal mass of $M_{e^*} = 200$ GeV we require the $e\gamma$ invariant mass to be greater than 180 GeV/c^2 , greater than 350 GeV/c^2 for $M_{e^*} = 400$ GeV, and greater than 500 GeV/c^2 for $M_{e^*} = 600$ GeV. The minimum mass cut is 500 GeV/c^2 for all signal masses above 600 GeV/c^2 because there is essentially zero background and increasing the cut does not improve our reach. With such low background expected, the only relevant consideration here is to maintain a high signal efficiency. The expected background contributions can be seen in Table 7.1. Figure 7.3 again shows the choice of the maximum mass, but with three signal masses depicted.

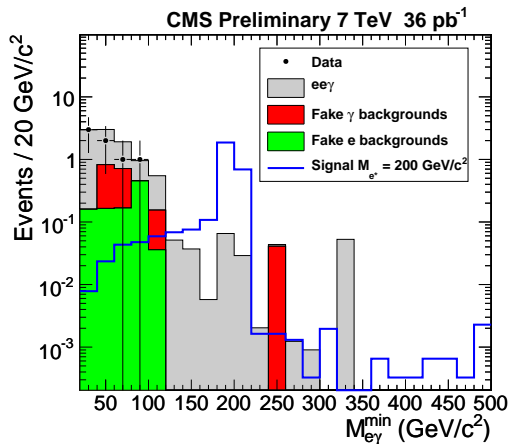

Figure 7.1: Invariant mass distribution for the choice of the lower invariant mass $e\gamma$ pair. Signal is $M_{e^*} = 200$ GeV/c^2 .

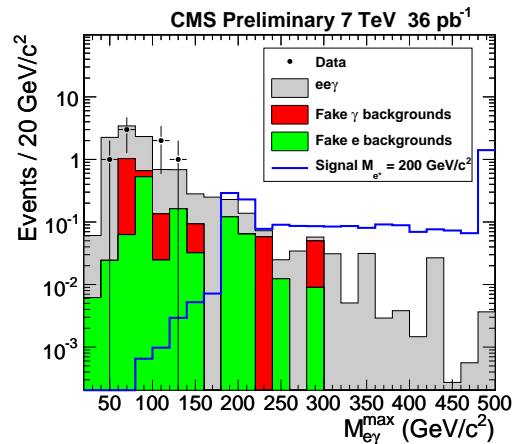

Figure 7.2: Invariant mass distribution for the choice of the higher invariant mass $e\gamma$ pair. Signal is $M_{e^*} = 200$ GeV/c^2 .

7.2 Event Yields and Limit Setting

After the full selection excluding the one-sided mass cut, we observe 7 events in data and we expect the following contributions from the SM background processes: 10.97 ± 1.02 events for $ee + \gamma$, 1.37 ± 0.83 events for $ee + jet(s)$, and 1.03 ± 0.35 events for $e\gamma + jet(s)$ final state topologies for a total of 13.37 ± 1.36 events. Reducing the M_{ee} cut to 25 GeV gives 9 events in data with the following

Table 7.1: Expected backgrounds broken down by type after final one-sided mass cuts of 180, 350, and 500 GeV/ c^2 respectively.

M_{e^*} [GeV]	$ee\gamma$	Fake γ	Fake e	Total Bkgd
200	$0.704 \pm 0.069 \pm 0.055$	$0.099 \pm 0.071 \pm 0.049$	$0.196 \pm 0.072 \pm 0.067$	0.999 ± 0.154
400	$0.095 \pm 0.032 \pm 0.011$	$0.000 \pm 0.047 \pm 0.014$	$0.000 \pm 0.032 \pm 0.012$	0.095 ± 0.068
600+	$0.006 \pm 0.014 \pm 0.001$	$0.000 \pm 0.047 \pm 0.014$	$0.000 \pm 0.032 \pm 0.012$	0.006 ± 0.061

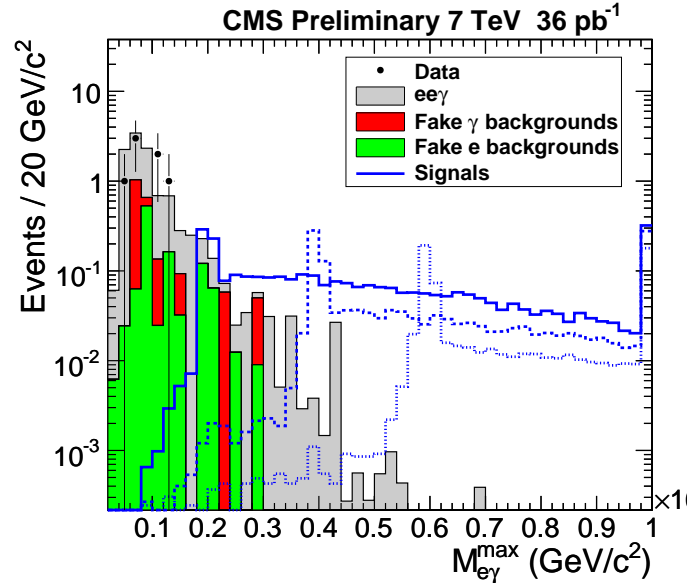

Figure 7.3: Invariant mass distribution for the choice of the higher invariant mass $e\gamma$ pair. Signals are $M_{e^*} = 200, 400, 600 \text{ GeV}/c^2$.

contributions from background: 12.29 ± 0.99 events for $ee + \gamma$, 1.37 ± 0.83 events for $ee + jet(s)$, and 1.06 ± 0.49 events for $e\gamma + jet(s)$ final state topologies for a total of 14.72 ± 1.38 events. The probability of observing 7 events with an expectation of 13.37 events is 0.055.

Table 7.2 shows the Standard Model event yield expectation, the number of e^* events we expect for various masses with $\Lambda = 2 \text{ TeV}$, and the cross section limit we set at 95% confidence level (CL). Table 7.3 shows event yields for other values of M_{e^*} and Λ . With a 0 background analysis one excludes at 95% CL for $M_{e^*} - \Lambda$ points where 3 events pass the final selection.

To set limits we search for events passing the full selection criteria that have an invariant mass for the larger of the two $e\gamma$ invariant mass choices above a minimum cut. The limit is calculated using a routine written by G. Landsberg [71] that uses Bayesian techniques to calculate the 95% CL limit for cross sections using Poisson statistics. A log-normal prior is used for the integration over the nuisance parameters (systematic uncertainties)[72]. The systematic uncertainties discussed Chapter 6.5 are those taken into account in the limit setting. The expected limit is computed by taking a weighted average of limits over all possible numbers of

Table 7.2: Passing data events and efficiencies for the full analysis. Λ is taken to be 4 TeV for the signal expectation column. Errors are reported as (stat.) \pm (syst.).

M_{e^*} [GeV]	$M_{e\gamma}^{max}$ cut	data	SM exp.	Sig. Eff (%)	$\sigma_{obs}^{lim}(\sigma_{exp}^{lim})[pb]$	Signal exp.
200	180	0	$0.999 \pm 0.147 \pm 0.100$	$38.7 \pm 0.3 \pm 1.7$	$0.21(0.30)$	40.62
400	350	0	$0.095 \pm 0.065 \pm 0.021$	$44.6 \pm 0.3 \pm 1.5$	$0.19(0.19)$	16.23
600	500	0	$0.006 \pm 0.058 \pm 0.019$	$47.0 \pm 0.3 \pm 1.7$	$0.18(0.18)$	6.36
800	500	0	$0.006 \pm 0.058 \pm 0.019$	$49.3 \pm 0.3 \pm 1.8$	$0.17(0.17)$	2.49
1000	500	0	$0.006 \pm 0.058 \pm 0.019$	$50.9 \pm 0.3 \pm 1.8$	$0.16(0.16)$	0.99
1200	500	0	$0.006 \pm 0.058 \pm 0.019$	$51.3 \pm 0.3 \pm 1.8$	$0.16(0.16)$	0.39
1500	500	0	$0.006 \pm 0.058 \pm 0.019$	$52.9 \pm 0.3 \pm 1.8$	$0.16(0.16)$	0.10

Table 7.3: Total number of events produced and passing the final one-sided cut for various values of M_{e^*} and Λ .

M_{e^*} [GeV]	$\Lambda = 1$ TeV		$\Lambda = 2$ TeV		$\Lambda = 4$ TeV		$\Lambda = 6$ TeV	
	Tot	Fin Sel	Tot	Fin Sel	Tot	Fin Sel	Tot	Fin Sel
200	1254.96	485.86	104.83	40.62	7.18	2.77	1.44	0.55
400	304.42	136.1	36.39	16.23	2.94	1.31	0.61	0.27
600	87.29	41.03	13.51	6.36	1.34	0.64	0.3	0.14
800	27.72	13.71	5.05	2.49	0.60	0.30	0.14	0.07
1000	9.62	4.9	1.93	0.99	0.27	0.14	0.07	0.03
1200	3.56	1.82	0.76	0.39	0.12	0.06	0.03	0.02
1500	0.83	0.45	0.18	0.10	0.03	0.02	0.01	0.01

observed events. The weight is the Poisson probability to observe a given number of events in data assuming the background-only hypothesis.

We have searched for evidence of electron compositeness in pp collisions at $\sqrt{s} = 7$ TeV by looking for the production of excited leptons followed by the decay to an electron and a photon. We do not observe any data events passing these mass cuts. Since no excess of events in the $ee\gamma$ final state was found above the SM expectation in the electron we report the first upper limits on e^* production at this collision energy[73]. We can also exclude a new region of the Λ - M_{e^*} parameter space. The limits set on Λ in M_{e^*} - Λ space and on the cross section as a function of e^* mass are shown in Figures 7.4 and 7.5. If we take the novel contact interaction scale to be $\Lambda = 2$ TeV, e^* masses below 760 GeV/ c^2 for electrons are excluded at the 95% CL. Assuming $\Lambda = M_{e^*}$ instead, excited electron masses are excluded below 1070 GeV/ c^2 representing the most stringent limits to date. The cross sections for masses between 200 and 1500 GeV/ c^2 are limited to less than 0.21 - 0.16 pb $^{-1}$.

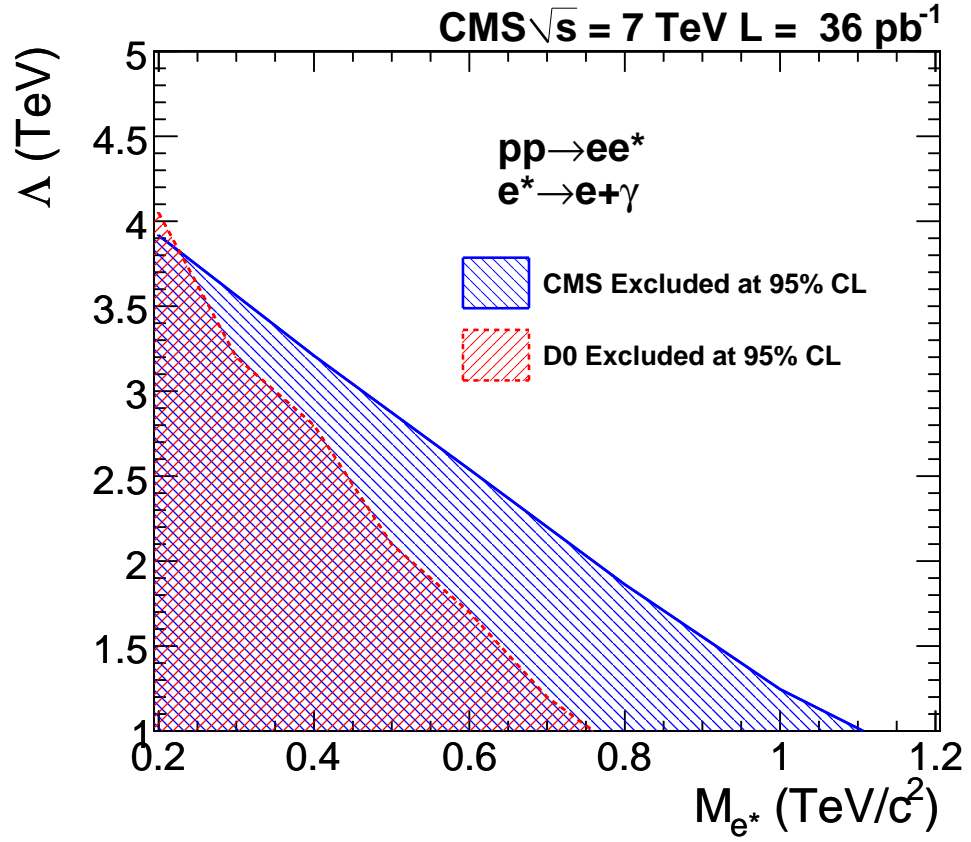

Figure 7.4: 95% confidence level exclusion limits in the Λ - M_{e^*} parameter space. The blue shaded region shows the limits from this analysis and the red shaded region shows the 1 fb^{-1} results from D0.

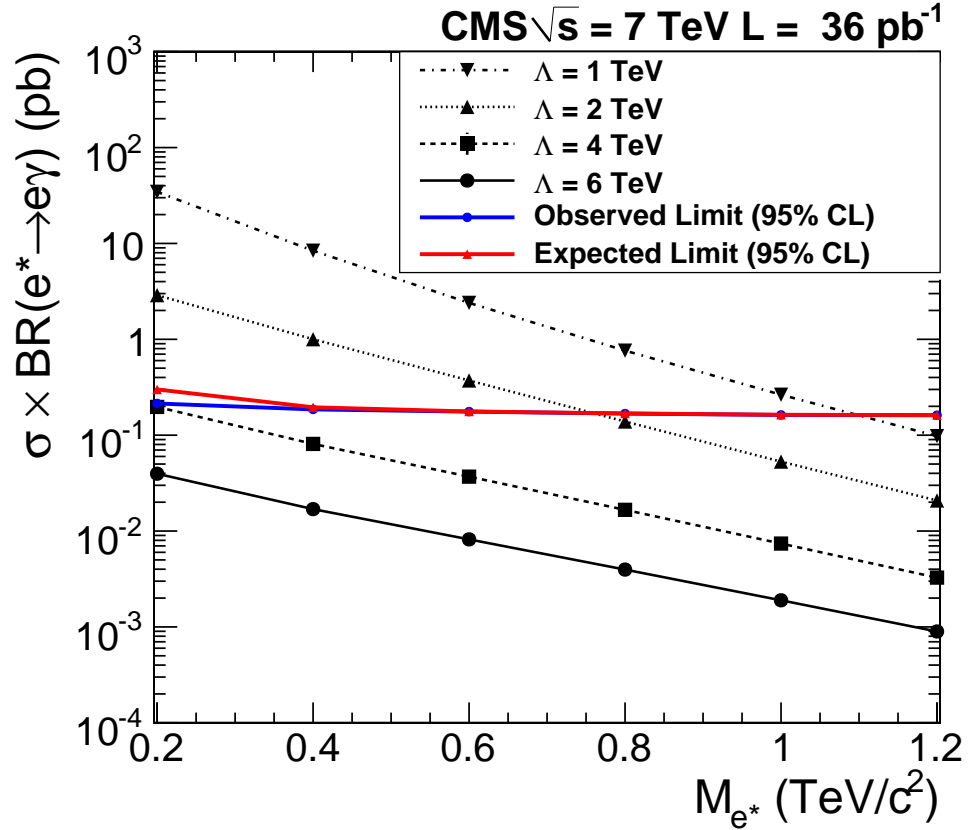

Figure 7.5: 95% confidence level exclusion limits on the cross section times branching fraction of $pp \rightarrow ee^* \rightarrow ee\gamma$. The red line shows the expected limits and the blue the observed limits. The cross section times branching fraction as a function of M_{e^*} is shown for four different choices of the Λ parameter.

Appendix A

Other Analysis Options

This analysis was streamlined for simplicity and robustness in the early running environment. Once the detector is better understood and more data collected, there are some further choices in the analysis that could yield better results. These choices and their effect on the final limit setting power will be discussed in the following sections.

A.1 Z Mass Window Removal

One cut that was considered for use in this analysis was to remove all events where the invariant mass of any combination of selected objects reconstructs to the Z mass (80-100 GeV/ c^2). This includes the ee mass, either $e\gamma$ mass, or the three-body ($ee\gamma$) mass. The major irreducible background for the analysis is $Z \rightarrow ee\gamma$, and the elimination of these events has a small effect on the signal efficiency, but significantly reduces the background for low e^* masses. The results including this veto are found in Table A.1.

The errors here are taken to be the same relative errors as those computed for the standard analysis. There is a 21.4% improvement in the cross section limit at 200 GeV/ c^2 which corresponds to a 6.3% improvement in the limit on Λ (all changes are tabulated in Table A.2). A positive value indicates a gain of power in the analysis. Figure A.1 shows the change in the expected reach of the exclusion in the Λ - M_{e^*} plane.

Table A.1: Passing data events and efficiencies when excluding events with any set of objects reconstructing to the Z mass. Errors are taken to be the same relative errors as those computed for standard analysis using the maximum $e\gamma$ invariant mass.

M_{e^*} [GeV]	$M_{e\gamma}^{max}$ cut	data	SM exp.	Sig. Eff (%)	σ_{obs}^{lim} (σ_{exp}^{lim})
200	180	0	0.135	37.7	0.22 (0.24)
400	350	0	0.030	44.0	0.19 (0.19)
600	500	0	0.001	46.6	0.18(0.18)
800	500	0	0.001	49.1	0.17(0.17)
1000	500	0	0.001	50.9	0.16 (0.16)
1200	500	0	0.001	51.3	0.16 (0.16)

Table A.2: Estimated changes in expected limits on the cross section and Λ if the events with any set of objects have an invariant mass near the Z mass are removed. A positive value indicates a gain of sensitivity.

M_{e^*} [GeV]	% Change in σ_{Exp}^{lim}	% Change in Λ
200	21.4	6.3
400	3.5	1.0
600	-0.6	-0.2
800	-0.2	-0.0
1000	0.3	0.1
1200	0.3	0.0

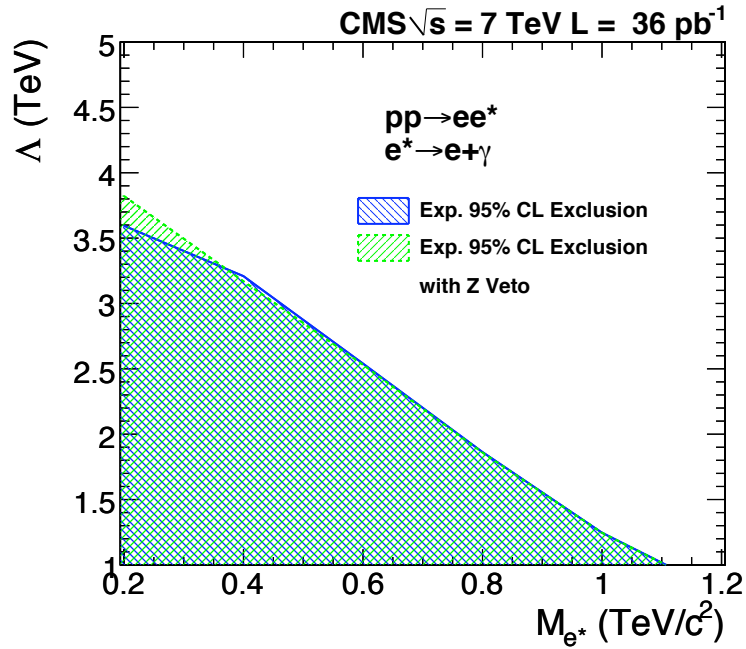

Figure A.1: Expected 95% Exclusion limits for the standard analysis presented in this paper and the estimated change in the limits if events with objects combining to give the invariant mass of the Z are excluded.

There is very little change in the exclusion limits for this analysis choice for masses above $200 \text{ GeV}/c^2$ since there is almost no background to be removed. A more careful check with all the proper errors computed could be done to see if there is any significant decrease for the masses above $200 \text{ GeV}/c^2$, but it is rather unlikely given the small effect on the signal efficiency. The improvement at $200 \text{ GeV}/c$ is large enough that the reinstatement of this cut for at least for low e^* masses is warranted, but for simplicity of the analysis this cut was not implemented.

A.2 Pixel Veto

An optional cut for the photon selection is the pixel veto. This rejects photons that have compatible hits in the pixel detector. It will mainly clean good electrons from the photon collection since they have similar properties of isolation and shower shape, but additionally have an associated track. Three electron backgrounds are not a large contributor to our analysis, but they do

occur. At low mass we will see some improvement to the limit due to a reduced background, but at high mass the limit is negatively impacted by the efficiency loss in the signal. The results including this veto are found in Table A.3.

Table A.3: Passing data events and efficiencies when including the pixel veto in the photon selection. Errors are taken to be the same relative errors as those computed for standard analysis using the maximum $e\gamma$ invariant mass.

M_{e^*} [GeV]	$M_{e\gamma}^{max}$ cut	data	SM exp.	Sig. Eff (%)	σ_{obs}^{lim} (σ_{exp}^{lim}) [pb]
200	180	0	0.651	37.3	0.22 (0.29)
400	350	0	0.088	43.2	0.19 (0.20)
600	500	0	0.006	45.7	0.18(0.18)
800	500	0	0.006	48.1	0.17(0.17)
1000	500	0	0.006	49.5	0.17 (0.17)
1200	500	0	0.006	49.9	0.17 (0.17)

The errors here are taken to be the same relative errors as those computed for the standard analysis. There is a 4.7% improvement in the cross section limit at 200 GeV/ c^2 which corresponds to a 1.2% improvement in the limit on Λ (all changes are tabulated in Table A.4). A positive value indicates a gain of power in the analysis. Figure A.2 shows the change in the expected reach of the exclusion in the Λ - M_{e^*} plane.

Table A.4: Estimated changes in expected limits on the cross section and Λ if the pixel veto criterion is used in the photon selection. A positive value indicates a gain of sensitivity.

M_{e^*} [GeV]	% Change in σ_{Exp}^{lim}	% Change in Λ
200	4.7	1.2
400	-2.8	-0.7
600	-2.9	-0.9
800	-2.6	-0.9
1000	-2.9	-1.2
1000	-2.8	-1.5

There is a slight loss of reach for masses above 200 GeV/ c^2 , and slight gain at 200 GeV/ c^2 . There is very little effect on the analysis from applying the pixel veto.

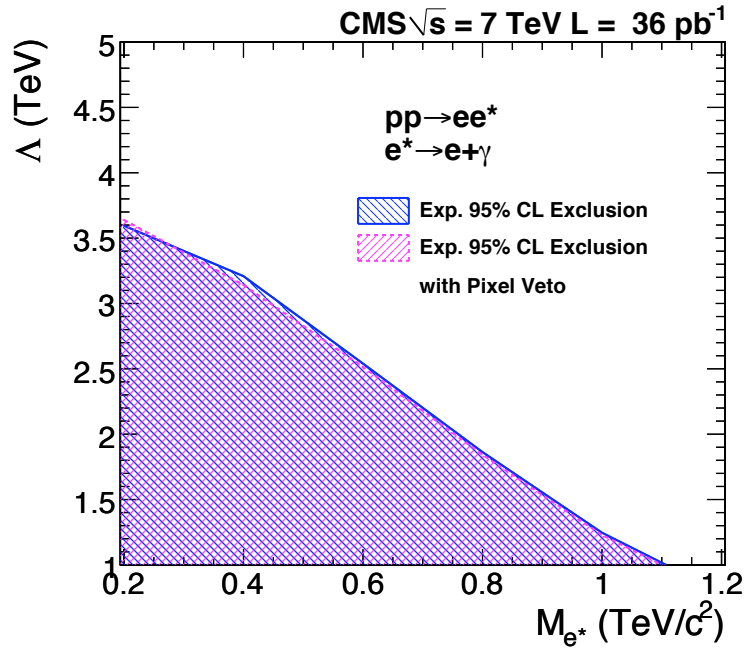

Figure A.2: Expected 95% Exclusion limits for the standard analysis presented in this paper and the estimated change in the limits if the pixel veto is included in the photon selection.

A.3 Endcap Photons

Photons with $|\eta| > 1.4442$ were excluded from the analysis because the final cut selection and fake rate analysis were not carried out for the 2010 run period. An analysis was performed to make a rough estimate of the efficiency loss due to this exclusion. To accomplish this, endcap photons were included in the range $1.566 < |\eta| < 2.5$ using the same photon selection as in the barrel. In the future, the endcap region will likely have a different selection. This change resulted in increased efficiency for all e^* mass points, but we also expect an increase in the contribution from Standard Model backgrounds, especially at low E_T . The fake rate from the barrel analysis was used to estimate the jet-faking-photon backgrounds in the endcap as well.

The errors here are taken to be the same relative errors as those computed for the standard analysis. The changes to the cross section limits range from about -16 % at $200 \text{ GeV}/c^2$ due to increased background (due in large part to

Table A.5: Estimated efficiency loss due to exclusion of EE region. Identical photon selection criteria (Table 5.5) are used for the endcap region.

M_{e^*} [GeV]	Efficiency Including Endcap	Raw Eff. Gain	Relative Eff. Gain
200	47.1%	8.4%	21.6%
400	52.7%	8.1%	18.1%
600	54.6%	7.6%	16.2%
800	56.0 %	6.7 %	13.5%
1000	57.1 %	6.1%	12.0%
1200	57.4 %	6.1%	11.9%

Table A.6: Passing data events and efficiencies for when including endcap photons. Errors are taken to be the same relative errors as those computed for standard analysis.

M_{e^*} [GeV]	$M_{e\gamma}^{max}$ cut	data	SM exp.	Sig. Eff (%)	$\sigma_{obs}^{lim} (\sigma_{exp}^{lim}) [pb]$
200	180	1	3.47	47.1	0.18 (0.35)
400	350	0	0.286	52.7	0.16 (0.18)
600	500	0	0.008	54.6	0.15(0.15)
800	500	0	0.008	56.0	0.15 (0.15)
1000	500	0	0.008	57.1	0.15 (0.15)
1200	500	0	0.008	57.4	0.14 (0.14)

fake photons) to almost 14% at 600 GeV/ c^2 . The change in limits on Λ range from -3.7% to 5.6% (all mass points are detailed in Table A.7). A negative value indicates a loss of power in the analysis. Figure A.3 shows the change in the reach of the exclusion in the Λ - M_{e^*} plane.

Table A.7: Estimated changes in expected limits on the cross section and Λ if endcap photons are included. A negative value indicates a loss of sensitivity.

M_{e^*} [GeV]	% Change in σ_{Exp}^{lim}	% Change in Λ
200	-16.1	-3.7
400	8.0	2.3
600	13.8	4.6
800	11.9	4.7
1000	10.7	5.0
1200	10.6	5.6

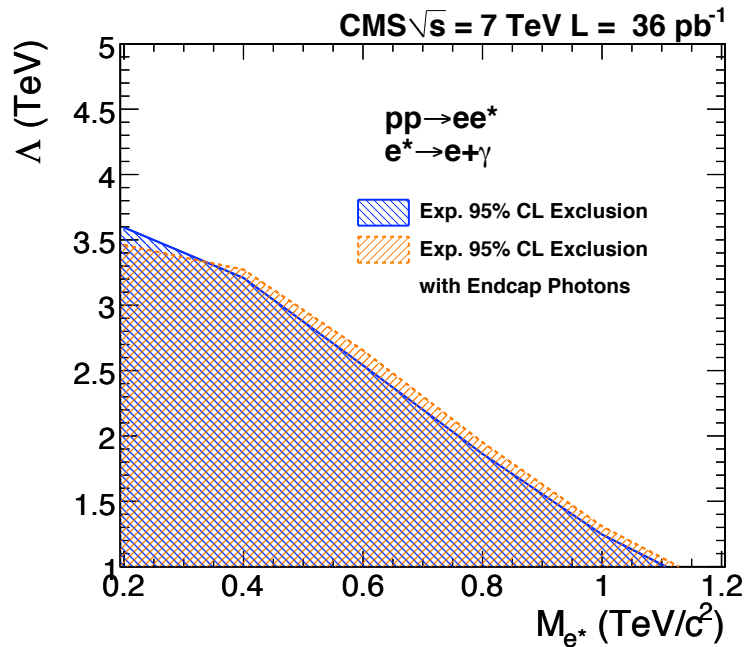

Figure A.3: Expected 95% Exclusion limits for the standard analysis presented in this paper and the estimated exclusion gained by including endcap photons.

For future iterations of the analysis it should be a priority to finish the photon identification analysis and include endcap photons in the search. The selection and fake rate should both be reexamined before including the endcap

photons. It is unclear that simply applying the fake rate measured in the barrel is a reasonable thing to do. There is the potential for significant improvement in the reach of this analysis by including the endcap region when the proper measurements are complete.

A.4 Both Mass Combinations

When deciding which $e\gamma$ pair to use for the final selection the decision was taken to choose the pair with higher invariant mass. This yields a high efficiency for all mass points and leaves us with a simple counting experiment. A small improvement can be made by instead choosing to use both pairs and a two-sided mass cut. For a simple estimation of this improvement we examined three e^* mass points, 200, 400, and 600 GeV/c^2 . The mass window was chosen to be symmetric around the generated mass. A 40 GeV/c^2 window is taken around 200 (to be consistent with the lower cut in the standard analysis) and for the other two points a 100 GeV/c^2 window is chosen. This choice could probably be further optimized, but at higher masses there is so little expected background that the limits are essentially unaffected by this choice as long as the window is sufficiently wide. For low masses the decrease in the expected background also makes a small difference. Figure A.4 shows the invariant mass distribution with both $e\gamma$ masses plotted and all three signal masses (200, 400, 600 GeV/c^2).

Table A.8: Passing data events and efficiencies for when using both mass combinations. Errors are taken to be the same relative errors as those computed for standard analysis using the maximum $e\gamma$ invariant mass.

M_{e^*} [GeV]	$M_{e\gamma}^{max}$ Window	data	SM exp.	Sig. Eff (%)	σ_{obs}^{lim} (σ_{exp}^{lim}) [pb]
200	180-220	0	0.859	40.0	0.21 (0.28)
400	350-450	0	0.082	49.6	0.17 (0.17)
600	550-650	0	0.006	50.8	0.16(0.16)

The errors here are taken to be the same relative errors as those computed for the standard analysis. The improvements to the cross section limits range from 7.4 % at 600 GeV/c^2 to 10.7% at 400 GeV/c^2 . The change in limits on Λ are much

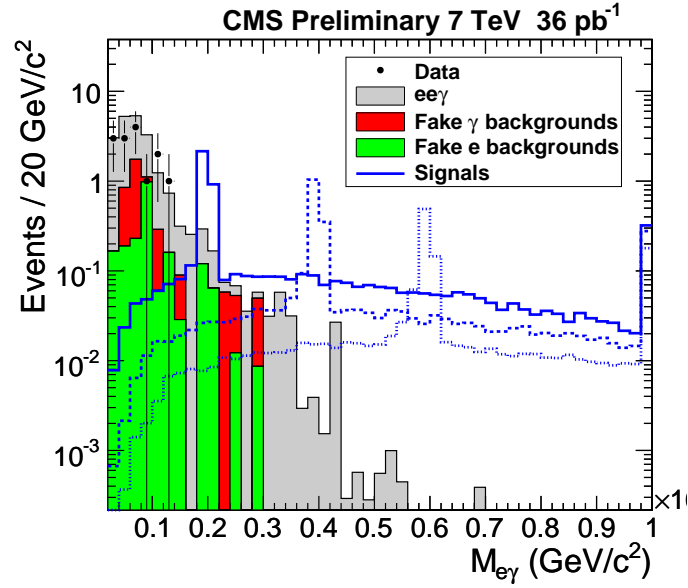

Figure A.4: Invariant mass distribution for both invariant mass $e\gamma$ pairs. Signal is $M_{e^*} = 200, 400, 600 \text{ GeV}/c^2$.

smaller and range from 1.6% to 3.1% (all three mass points are detailed in Table A.9). A positive value indicates a gain of power in the analysis. Figure A.5 shows the change in the reach of the exclusion in the Λ - M_{e^*} plane.

Table A.9: Estimated changes in expected limits on cross section and Λ if both $e\gamma$ invariant masses are included and a symmetric, two-sided cut is imposed. A positive value indicates a gain of sensitivity.

$M_{e^*} [\text{GeV}]$	% Change in σ_{Exp}^{lim}	% Change in Λ
200	6.0	1.6
400	10.7	3.1
600	7.4	2.4

A more careful examination of this choice dealing with potential double counting and optimizing the window should be carried out to determine if there is a real improvement, and for what excited electron masses, when the limit setting is properly done. There is very little gain on the Λ limits in this estimation, but is possible that improved limits could be set using this final variable choice.

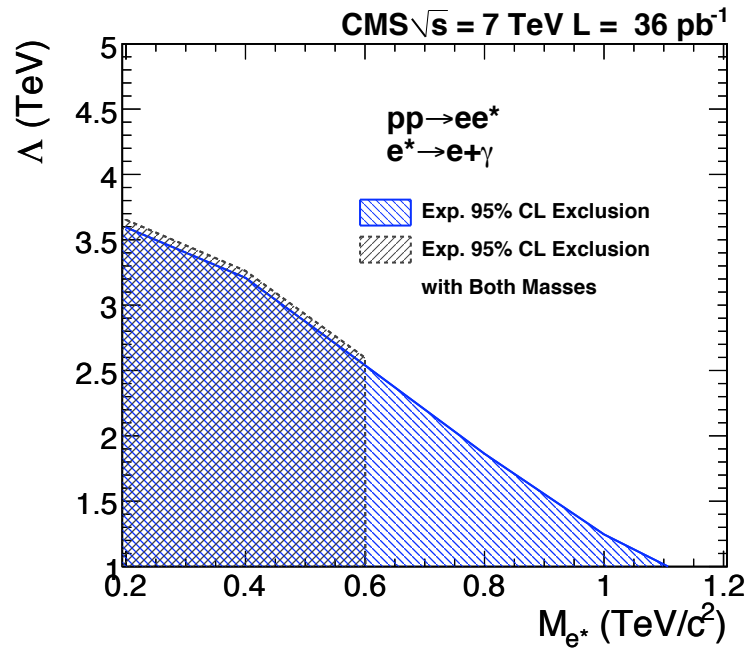

Figure A.5: Expected 95% Exclusion limits for the standard analysis presented in this paper and the estimated exclusion gained by using both invariant mass combinations.

Bibliography

- [1] D. Griffiths. *Introduction to Elementary Particles*. John Wiley & Sons, 1987.
- [2] F. Halzen and A. Martin. *Quarks & Leptons: An Introductory Course in Modern Particle Physics*. John Wiley & Sons, 1984.
- [3] S. L. Glashow. Partial Symmetries of Weak Interactions. *Nucl. Phys.*, 22:579–588, 1961.
- [4] Abdus Salam. Renormalizability of gauge theories. *Phys. Rev.*, 127:331–334, 1962.
- [5] Steven Weinberg. A Model of Leptons. *Phys. Rev. Lett.*, 19:1264–1266, 1967.
- [6] H. David Politzer. Asymptotic Freedom: An Approach to Strong Interactions. *Phys. Rept.*, 14:129–180, 1974.
- [7] D. J. Gross and Frank Wilczek. Ultraviolet Behavior of Non-Abelian Gauge Theories. *Phys. Rev. Lett.*, 30:1343–1346, 1973.
- [8] F. Englert and R. Brout. Broken Symmetry and the Mass of Gauge Vector Mesons. *Phys. Rev. Lett.*, 13:321–322, 1964.
- [9] Peter W. Higgs. Broken Symmetries and the Masses of Gauge Bosons. *Phys. Rev. Lett.*, 13:508–509, 1964.
- [10] G. S. Guralnik, C. R. Hagen, and T. W. B. Kibble. Global Conservation Laws and Massless Particles. *Phys. Rev. Lett.*, 13:585–587, 1964.
- [11] CMS Collaboration. New cms higgs search results for the lepton photon 2011 conference. <http://cms.web.cern.ch/cms/News/2011/LP11/>, Aug 2011.
- [12] ATLAS Collaboration. Atlas advances in the search for the higgs and new physics. <http://atlas.ch/news/2011/ATLAS-advances-in-search-for-Higgs.html>, Aug 2011.
- [13] Steven Weinberg. Baryon- and lepton-nonconserving processes. *Phys. Rev. Lett.*, 43:1566–1570, Nov 1979.

- [14] Hidezumi Terazawa, Masaki Yasue, Keiichi Akama, and Masaki Hayashi. Observable Effects of the Possible Substructure of Leptons and Quarks. *Phys. Lett.*, B112:387, 1982.
- [15] F. Boudjema, A. Djouadi, and J. L. Kneur. Excited fermions at $e^+ e^-$ and $e p$ colliders. *Z. Phys.*, C57:425–450, 1993.
- [16] U. Baur, M. Spira, and P. M. Zerwas. Excited-quark and -lepton production at hadron colliders. *Phys. Rev D*, 42:815, 1990.
- [17] DELPHI Collaboration. Search for composite and exotic fermions at LEP2. *Eur. Phys. J.*, C8:41–58, 1999.
- [18] DELPHI Collaboration. Search for excited leptons in $e^+ e^-$ collisions at $s^{1/2} = 189\text{-GeV} - 209\text{-GeV}$. *Eur. Phys. J.*, C46:277–293, 2006.
- [19] ALEPH Collaboration. Search for excited leptons at $130\text{-GeV} - 140\text{-GeV}$. *Phys. Lett.*, B385:445–453, 1996.
- [20] L3 Collaboration. Search for excited leptons at LEP. *Phys. Lett.*, B568:23–34, 2003.
- [21] OPAL Collaboration. Search for unstable heavy and excited leptons at LEP2. *Eur. Phys. J.*, C14:73–84, 2000.
- [22] H1 Collaboration. Search for Excited Electrons in ep Collisions at HERA. *Phys. Lett.*, B666:131–139, 2008.
- [23] ZEUS Collaboration. Search for excited fermions in $e p$ collisions at HERA. *Acta Phys. Polon.*, B33:3899–3904, 2002.
- [24] D0 Collaboration. Search for excited electrons in p anti- p collisions at $s^{1/2} = 1.96\text{-TeV}$. *Phys. Rev.*, D77:091102, 2008.
- [25] CDF Collaboration. Search for excited and exotic electrons in the e gamma decay channel in p anti- p collisions at $s^{1/2} = 1.96\text{-TeV}$. *Phys. Rev. Lett.*, 94:101802, 2005.
- [26] Lyndon Evans, (ed.) and Philip Bryant, (ed.). LHC Machine. *JINST*, 3:S08001, 2008.
- [27] UA1 Collaboration. Experimental observation of isolated large transverse energy electrons with associated missing energy at $s^{1/2} = 540\text{-GeV}$. *Phys. Lett.*, B122:103–116, 1983.
- [28] UA1 Collaboration. Experimental observation of lepton pairs of invariant mass around $95\text{-GeV}/c^2$ at the CERN SPS collider. *Phys. Lett.*, B126:398–410, 1983.

- [29] UA2 Collaboration. Observation of single isolated electrons of high transverse momentum in events with missing transverse energy at the CERN anti-p p collider. *Phys. Lett.*, B122:476–485, 1983.
- [30] UA2 Collaboration. Evidence for $Z^0 \rightarrow e^+ e^-$ at the CERN anti-p p collider. *Phys. Lett.*, B129:130–140, 1983.
- [31] CDF Collaboration. Observation of top quark production in anti-p p collisions. *Phys. Rev. Lett.*, 74:2626–2631, 1995.
- [32] D0 Collaboration. Observation of the top quark. *Phys. Rev. Lett.*, 74:2632–2637, 1995.
- [33] ATLAS Collaboration. The ATLAS Experiment at the CERN Large Hadron Collider. *JINST*, 3:S08003, 2008.
- [34] LHCb Collaboration. The LHCb Detector at the LHC. *JINST*, 3:S08005, 2008.
- [35] ALICE Collaboration. The ALICE experiment at the CERN LHC. *JINST*, 3:S08002, 2008.
- [36] TOTEM Collaboration. The TOTEM experiment at the CERN Large Hadron Collider. *JINST*, 3:S08007, 2008.
- [37] LHCf Collaboration. The LHCf detector at the CERN Large Hadron Collider. *JINST*, 3:S08006, 2008.
- [38] CERN Press Office. <http://cdsweb.cern.ch/collection/Press%20Office%20Photo%20Selection?ln=en>.
- [39] CMS Collaboration. CMS physics: Technical design report. CERN-LHCC-2006-001.
- [40] CMS Collaboration. CMS technical design report, volume II: Physics performance. *J. Phys.*, G34:995–1579, 2007.
- [41] CMS Collaboration. The CMS experiment at the CERN LHC. *JINST*, 3:S08004, 2008.
- [42] CMS Press Office. http://cms.web.cern.ch/cms/Resources/Website/Media/Images/Detector/DetectorDrawings/fromGEANT/cms_complete_labelled.pdf.
- [43] <http://www.hephy.at/typo3temp/pics/72507b002e.png>.
- [44] Claude Amsler et al. Mechanical Design and Material Budget of the CMS Barrel Pixel Detector. *JINST*, 4:P05003, 2009.

- [45] CMS Collaboration. CMS: The TriDAS project. Technical design report, Vol. 2: Data acquisition and high-level trigger. CERN-LHCC-2002-026.
- [46] CMS Collaboration. The Data Acquisition System of the CMS Experiment at LHC. In *International Conference on Computing in High Energy and Nuclear Physics*, 2010.
- [47] CMS Collaboration. CMS. The TriDAS project. Technical design report, vol. 1: The trigger systems. CERN-LHCC-2000-038.
- [48] CMS Collaboration. <https://twiki.cern.ch/twiki/bin/view/CMSPublic/WorkBookComputingModel>.
- [49] CMS Collaboration. The CMS Reconstruction Software. In *International Conference on Computing in High Energy and Nuclear Physics*, 2010.
- [50] Torbjorn Sjostrand, Stephen Mrenna, and Peter Z. Skands. PYTHIA 6.4 Physics and Manual. *JHEP*, 05:026, 2006.
- [51] Johan Alwall et al. MadGraph/MadEvent v4: The New Web Generation. *JHEP*, 09:028, 2007.
- [52] M. A. Dobbs et al. Les Houches guidebook to Monte Carlo generators for hadron collider physics. 2004.
- [53] S. Agostinelli et al. GEANT4: A simulation toolkit. *Nucl. Instrum. Meth.*, A506:250–303, 2003.
- [54] ROOT: A Data Analysis Framework. <http://root.cern.ch>.
- [55] J. Pumplin et al. New generation of parton distributions with uncertainties from global QCD analysis. *JHEP*, 07:012, 2002.
- [56] M. Marone. Measurement of the pp inelastic cross section using pile-up events. In *DIS Conference*, 2011.
- [57] CMS Collaboration. Electron reconstruction and identification at $\sqrt{s} = 7\text{tev}$. *CMS PAS*, 2010/004, 2010.
- [58] CMS Collaboration. Electromagnetic calorimeter commissioning and first results with $\sqrt{s} = 7\text{tev}$. *CMS PAS*, 2010/002, 2010.
- [59] CMS Collaboration. Photon reconstruction and identification at $\sqrt{s} = 7\text{tev}$. *CMS PAS*, 2010/005, 2010.
- [60] Cms luminosity collision data 2010. <https://twiki.cern.ch/twiki/bin/view/CMSPublic/LumiPublicResults2010>.

- [61] CERN Bulletin. The latest from the lhc: Successful switch to ions. 46-47, 2010. <http://cdsweb.cern.ch/journal/CERNBulletin/2010/46/News%20Articles/1306161?ln=en>.
- [62] CMS Collaboration. CMS Tracking Performance Results from early LHC Operation. *Eur. Phys. J.*, C70:1165–1192, 2010.
- [63] U. Baur and Edmond L. Berger. Probing the weak boson sector in Z gamma production at hadron colliders. *Phys. Rev.*, D47:4889–4904, 1993.
- [64] CMS Collaboration. Egamma HLT in CMSSW. <https://twiki.cern.ch/twiki/bin/view/CMSPublic/SWGuideEgamaHLT>.
- [65] CMS Collaboration. Search for Resonances in the Dilepton Mass Distribution in pp Collisions at $\sqrt{s} = 7$ TeV. *JHEP*, 05:093, 2011.
- [66] CMS Collaboration. Isolated photon reconstruction and identification at $\sqrt{s} = 7$ TeV. *CMS PAS*, 2010/006, 2010.
- [67] CMS Collaboration. Measurement of Inclusive W and Z Cross Sections in pp Collisions at $\sqrt{s} = 7$ TeV. *CMS PAS*, 2010/002, 2010.
- [68] CMS Collaboration. Search for Large Extra Dimensions in the Diphoton Final State at the Large Hadron Collider. *JHEP*, 05:085, 2011.
- [69] CMS Collaboration. Absolute luminosity normalization. *CMS Detector Performance Summary*, CMS-DP-2011-003, 2011.
- [70] E. Boos et al. CompHEP 4.4: Automatic computations from Lagrangians to events. *Nucl. Instrum. Meth.*, A534:250–259, 2004.
- [71] G. Landsberg. Bayesian 95% cl limit calculator. <https://twiki.cern.ch/twiki/pub/CMS/EXOTICA/cl95cms.c>.
- [72] Joel Heinrich et al. Interval estimation in the presence of nuisance parameters. 1. Bayesian approach. 2004.
- [73] CMS Collaboration. A search for excited leptons in pp Collisions at $\sqrt{s} = 7$ TeV. *Phys. Lett.*, B704:143–162, 2011.