

# BE Department Annual Report 2014

G. Arduini, R. Billen, O. Brüning, P. Collier, R. Garoby, E. Hatziangeli,  
E. Jensen, R. Jones, M. Lamont, A. Mackney

## Abstract

The Beams Department hosts the Groups responsible for the beam generation, acceleration, diagnostics, controls and performance optimization for the whole CERN accelerator complex. This Report describes the 2014 highlights for the BE Department.



# LHC:

## **BE-ABP [Group](#)**

### **LHC LS1**

The main focus of 2014 LHC-related activities has been the study of options for optical configurations to be used in Run II. A clear roadmap has been produced, defining three scenarios: no change with respect to Run I optics (OPT\_MIN); change in IR4 configuration to cope with the requests to increase the values of beta-functions at the location of key instruments to improve their performance (OPT\_MED); a radical change of optics configuration meant to implement an ATS-like optics (OPT\_MAX). It is worth mentioning that OPT\_MED implies also a change of optics in IR8 for Beam 2 in order to keep the overall phase advance over the ring constant.

Following the preparation of the optics for the three options, intense efforts have been devoted to their validation. This is based on the analysis of the dynamic aperture at injection and collision as well as on simulation of the cleaning efficiency of the collimator system. The first step has been the relative comparison of OPT\_MIN and OPT\_MAX. While the performance in terms of dynamic aperture was comparable, the cleaning efficiency showed some differences. In particular, numerical simulations showed an increased number of loss spikes for OPT\_MAX, together with a less favourable phase advance between MKD and TCT in point 5 for Beam 2. This observation resulted in the decision that more studies were needed, in particular with beam, before OPT\_MAX could be accepted as operational optics. Therefore, the activities shifted to the comparison between OPT\_MIN and OPT\_MED. In this case the overall performance turned out to be very similar (see the dynamic aperture plots in Fig. AA), but the latter option allowed to improve the performance of the beam instrumentation. Therefore, OPT\_MED has been selected as the optical configuration for Run II, or at least for the first part of such a run.

This decision implied a major re-organisation of the optics database, also based on the experience gained from Run I, and the preparation of all the configurations required for the run, namely squeeze sequences, de-squeeze sequences etc., not to mention the optimisation required by the non-conformities found during the hardware commissioning.

Continuing analysis of heavy ion operation in Run I was an important foundation for studies on the future of the LHC heavy ion programme. In Run II, Pb-Pb luminosity is already expected to exceed the design and new strategies will be implemented to level luminosity and control the secondary beams emerging from the collisions. Studies on the upgraded (HL-LHC) performance in Run III and beyond evaluated the potential LHC performance with various injector upgrades and evaluated upgrades, such as dispersion suppressor collimators and a possible stochastic cooling system, to the LHC itself.

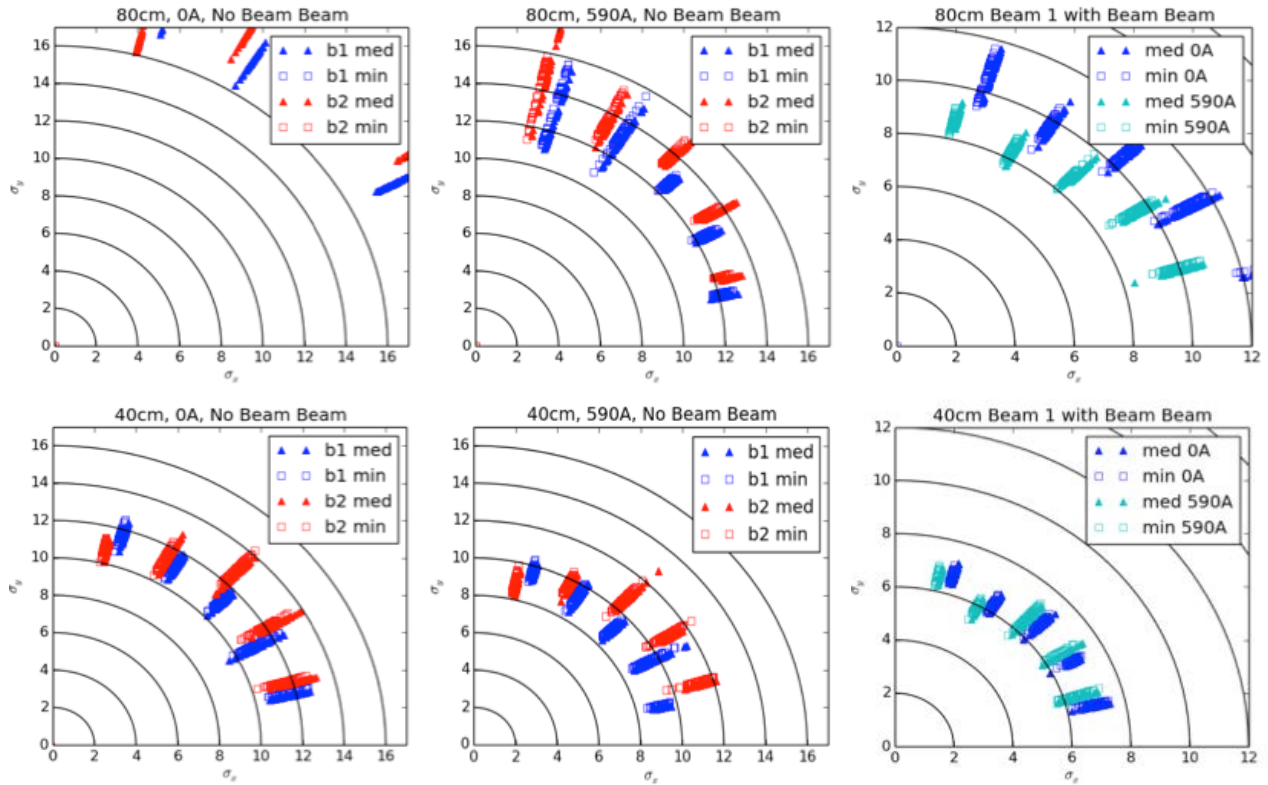

Figure 1: Results of dynamic aperture simulations for OPT\_MIN and OPT\_MED. The initial value of  $\sigma_y$  of 80 cm (upper row) and the extreme one of 40 cm (lower row) are shown. The situation without Landau octupoles (left column), with Landau octupoles (centre column) and with beam-beam effects (right column) are reported. No systematic difference between OPT\_MIN and OPT\_MED is visible. Each point represents the last amplitude stable up to  $10^5$  turns of one of the sixty realisations of the LHC machine used in the numerical simulations.

## BE-BI [Group](#)

### LHC LS1

The LHC wire scanners (BWS) were all removed for consolidation to increase their operational lifetime following higher than expected usage in Run 1. This required an extensive re-build that took until June 2014. The LHC Schottky monitors (BQS) also required an extensive re-build to solve vacuum outgassing and performance issues encountered in Run 1.

2014 also saw the installation of prototypes for HL-LHC, the beam gas vertexing monitor and cryogenic BLMs, both of which are described later.

Some 2300 beam-loss ionisation chambers that had been removed to allow access to superconducting magnets for the SMACC project were re-installed, following the magnet schedule. Some 30% were also re-positioned to gain operational sensitivity.

Overall, some 10% of the 2173 beamline instruments installed in the LHC and injector chain were removed and re-installed during LS1, with many seeing significant modification, along with more than 50% of the 4508 instruments not in vacuum. 99.5% of the activities planned for the shutdown were successfully completed, along with many more not in the original schedule.

## LHC Schottky:

The overhaul of all four 4.8GHz Schottky pick-ups and their electronic read-out systems was completed. The new pick-ups, depicted in Figure 2 and based on a full copper structure, have optimized RF properties reducing reflections and coherent signal content.

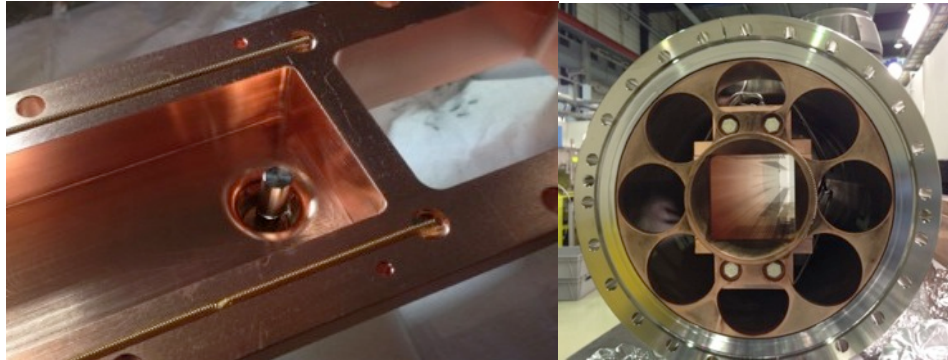

Figure 2: Left - new waveguide to coaxial coupler. Right - Schottky pick-up mounted in its vacuum vessel.

## LHC quench test analysis

At the end of the LHC Run1 a 48-hour quench-test campaign took place to investigate the quench levels of superconducting magnets for loss durations from nanoseconds to tens of seconds. The longitudinal losses produced extended from one meter to hundreds of meters and the number of lost protons varied from few  $10^8$  to few  $10^{13}$ . The results of these, and other previously conducted quench experiments, allow the quench levels of several types of LHC magnets under various loss conditions to be assessed. In the future, quench levels are expected to limit LHC performance in the case of steady-state losses in the interaction regions and also in the case of fast losses initiated by dust particles all around the ring. It is therefore important to accurately adjust beam loss abort thresholds in order to maximize operation time. The model used to predict the quench curve of a magnet (see Figure 3) has been verified for different loss durations. For short and long loss durations the model and measurements agree very well, but the agreement is less precise for intermediate loss durations. This is probably due to a combination of the more complex model required to describe such losses, with more uncertainty on the input parameters, and the fact that these measurements have a larger systematic error because of the way in which these losses were generated. For LHC Run 2 it has therefore been decided to adopt the least conservative strategy for intermediate loss duration quench levels, with the levels first set to the highest measured quench value in Run 1, to be reduced in case a quench occurs.

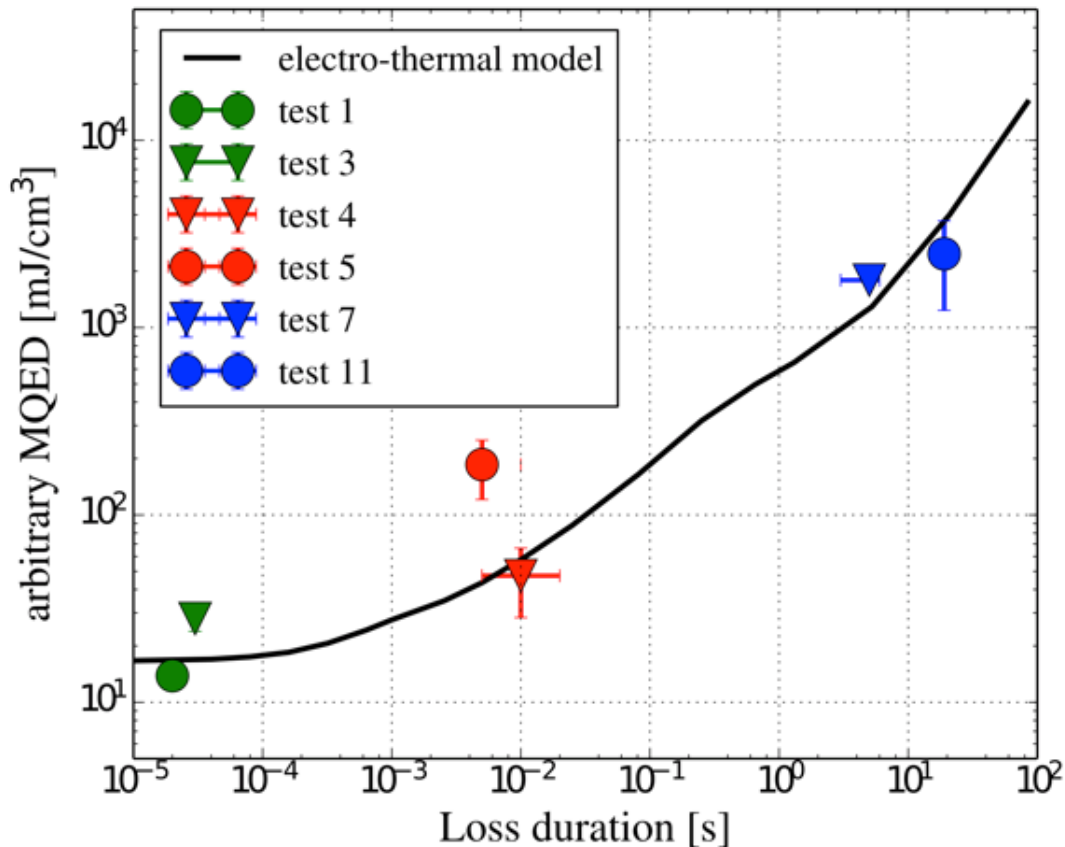

Figure 3: Illustration of results obtained during Run 1 quench tests, with the electro-thermal model denotes the quench level obtained from heat transfer simulations. This generic curve does not represent a particular magnet type or current.

### LHC dry-runs

Recommissioning the LHC control system following numerous changes at many layers made the staged planning of dry-runs necessary. BI systems are systematically used for checking: LHC beam injection with varying beam intensity and bunch patterns; circulating beam for a wide variety of configurations; extracted beam with additional requests to provide dedicated acquisitions for beam-dump and post-mortem analysis. Several sessions were scheduled during 2014 to gradually re-commission the hardware and software for all BI systems with the aim of being fully operational for the LHC injection and sector test.

## BE-CO [Group](#)

### Accelerator Fault Tracking

A new project to develop an Accelerator Fault Tracking (AFT) system was launched at the end of February 2014 by BE-CO together with stakeholders from the Operations teams. Amongst the aims of the project are the ability to be able to facilitate answering questions like: “Why are we not doing Physics when we should be?” and “What can we do to increase machine availability?”

People have tracked faults for many years, using numerous diverse, distributed and un-related systems. As a result, and despite a lot of effort, it has been difficult to get a clear and consistent overview of what is going on, where the problems are, how long they last for, and what is the impact. This is particularly true for the LHC, where faults may induce long recovery times after being fixed.

The project was divided into 3 phases, with the 1st phase due for completion ahead of LHC restart in 2015, and aimed at delivering the means to achieve consistent and coherent data capture for LHC, from an operational perspective. Phase 2 of the project is foreseen to focus on detailed fault capture for equipment groups, and Phase 3 for extended integration with other systems such as asset management intervention tracking to be able to facilitate predictive failure analyses and plan preventive maintenance operations.

By the end of 2014, the first production ready version of AFT was deployed and being tested by the stakeholders.

The AFT system has been designed to be non-LHC specific, and therefore is able to cater for fault tracking for other CERN accelerators and their sub-systems if so desired.

The technologies involved are an Oracle database, a Java server with APIs for data exchange with the Operations teams Logbooks, and data extraction and visualization via a Web application.

### **Accelerator Performance Statistics**

Accelerator performance statistics applications in general have been around for a very long time. However different people for each accelerator have always implemented them in different ways, using different technologies. Maintaining or extending these applications was never simple. In mid-2014 a project was started to develop new statistics calculation software, together with interactive statistics application with the requirements that it be: visible on the Web, from outside CERN, and have the potential to cover any of our accelerators.

By the end of 2014, the statistics calculations engines were fully operational for PS, PSB, SPS, and LHC. The new Web application was also deployed in production, covering the needs of the LHC, with the injectors set to follow in early 2015.

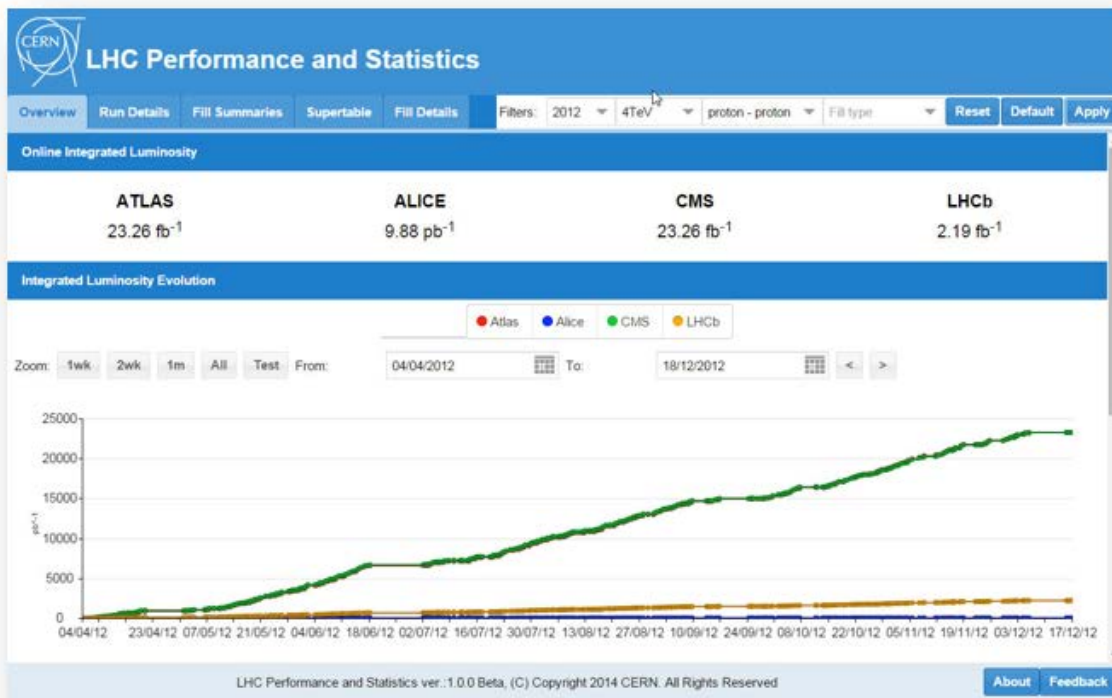

**Figure 4: First production-ready version of the new Statistics Application for LHC**

In terms of technologies used, the data comes purely from the Logging Service database; there is a Java server for performing LHC value calculations and writing results to the Logging database (for the injectors the data is calculated inside the database), a Java server with a RESTful API for data extraction, and the client Web application built using the Ext JS JavaScript framework.

### Beam Loss Threshold Calculations

In 2014 BE-CO fulfilled the BE-BI request made during 2013 to implement and maintain a software engine for calculating the beam dump thresholds for LHC beam losses. Since 2008, all LHC beam loss monitor operational data has been managed using BE-CO software, with the exception of the actual beam loss threshold calculations that were previously performed in C code developed and maintained by temporary people in BE-BI.

Developing PL/SQL code inside the LSA settings management database provided the missing piece in the puzzle, to calculate thresholds on-demand based on inputs of BE-BI and other beam loss experts. In addition the Java API that allows BE-BI to interface with the BLM data has been extended to support the new loss threshold calculations. This infrastructure is fully protected by RBAC, and database level restrictions.

All software has been developed according to the technical specifications provided by BE-BI, and has been thoroughly tested ahead of resuming LHC operations in 2015. Despite the calculations being now performed by BE-CO software, BE-BI and other beam loss experts with appropriate privileges remain fully responsible for the beam loss thresholds that are produced based on their inputs and validations after the calculation phase.

## Controls Configuration Service

2014 marks the beginning of the first service-wide renovation for the Controls Configuration Service (CCS) in its >30 years history. Alongside experiences of LS1, organisational changes, and adaption of new development practices such as Kanban, a major overhaul of the CCS started in the middle of 2014. The renovation of the service addresses: high technical-debt cumulated over the years; a complex review of the role of the CCS within the Controls infrastructure; establishment of a clear strategy for the coming years.

Integration between the CCS and LSA has been improved lowering the support on both sides. The mechanism for FESA3 promotion, together with migration of FESA2 to FESA3 was completely re-implemented – resulting in a considerable reduction in the time needed to adapt to the latest facilities of FESA3. The Data Browser (primary tool to access CCS data) has been re-factored and updated to better match end-user needs. By adapting the BE-CO Data Services common conventions and standards together with the BE-CO Commons4Oracle software library, development efficiency has increased noticeably.

## WorldFIP QPS infrastructure doubling

During LS1, to offload bandwidth of QPS FIP networks, each segment has been cut in two at the first repeater in the tunnel parts, and in the middle for UA. This involves new front-end computers, new Copper/Optical repeaters, new Timing connexions and diagnostic agents. A full electrical and performance qualification of the 88 QPS WorldFIP networks, old and new, has also been carried out by the BE-CO hardware installation team following the LHC qualification procedure.

Figure 5:

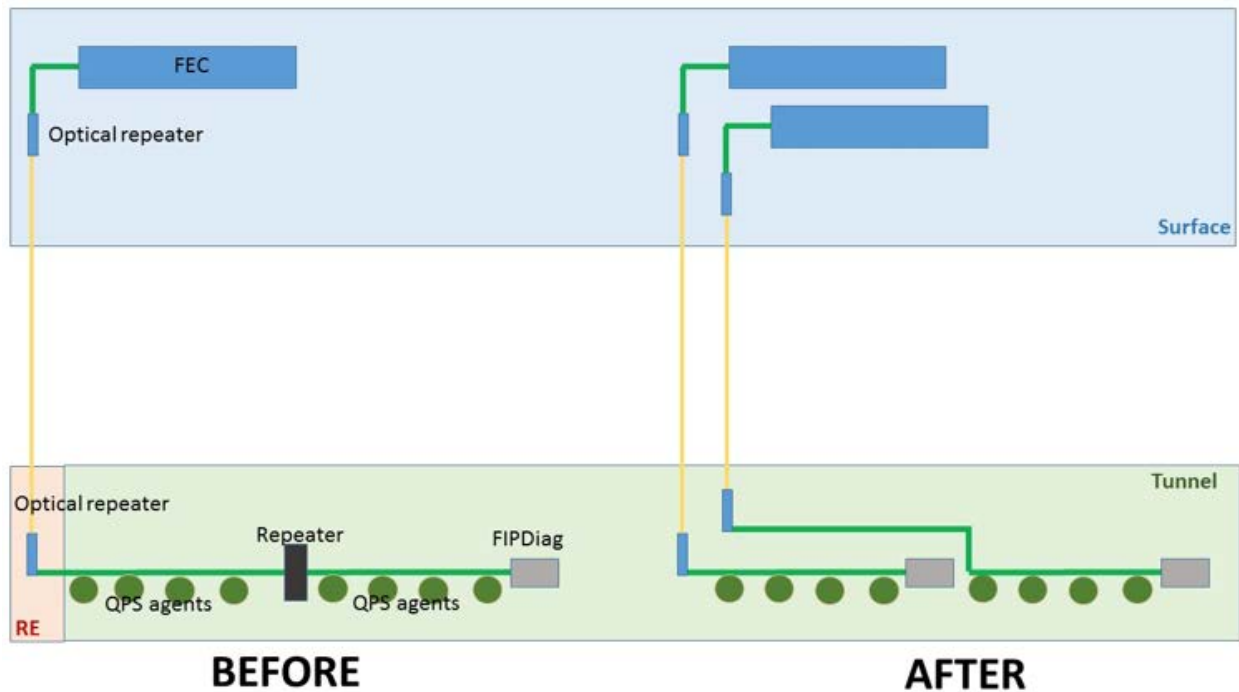

20 Gateways  
20 Timing card  
41 FIPDiag (or NanoFIPDiag)  
41 TAP Fip

41 FIP PMC cards 1Mhz  
66 Repeater Copper / Optical  
106 FIP Connectors FIP



## Front-end Renovations

During LS1, about 250 VMEbus PowerPC front-end systems have been upgraded to the Intel multi-core architecture and Linux operating system. At the same time, about 200 “Industrial PCs” used for the control of Power converters, QPS and Cryogenics have also been upgraded to the PICMG1.3 architecture.

## Hardware

The core activity in 2014 was to continue complementing and improving the standard modules kit based on FMC mezzanines and carriers. The White Rabbit (WR) project saw the release of a new version of the switch FPGA and embedded software supporting virtual local networks (VLAN) and remote management through SNMP. Work on IEEE-1588 standardization of WR technology also progressed, in particular through the presentation of a detailed plan to boost the accuracy of current IEEE-1588 implementations based on WR ideas. The [8<sup>th</sup> White Rabbit](#) workshop brought many developers from companies and institutes at CERN to share WR experience and discuss future developments. A WR-based system was designed for the distribution of triggers in the context of the study of beam instabilities in the LHC.

Insourcing of WorldFIP technology continued, in particular through the study of the design documents of the copper-fibre repeaters and the management of a production batch of 100 units. This is part of CO's plans to ultimately gain full control at the design level of all WorldFIP technology deployed in the LHC, including bus arbiters, repeaters and solutions to implement bus agents.

## BE-OP [Group](#)

With the continuation of the Long Shutdown 1 (LS1) until the middle of the year all members of the LHC operation section continued their involvement in the different activities related to the magnet circuit consolidation.

Three members of the section led the Coordination Support and Infrastructure (CSI) office for the high level coordination of all splice and magnet consolidation activities. This team monitored and coordinated the progress of the work, managed upcoming non-conformities and provided the interface between the various activities.

A large team of operation group members from the different sections contributed to the quality control of the LHC main interconnection splices, an activity that was led by the LHC operation section. The busbar stabilizer splices were consolidated during this first long LHC shutdown by soldering additional Copper shunts. In view of the large number of quality controls that were integrated in the splice consolidation process, efficient and unambiguous quality control procedures were developed and implemented in the field. Direct current electrical resistance measurements were performed for the control of the busbar splices and the individual shunts. About 400 000 resistance measurements performed at room temperature before and after each consolidation step were made by the quality control teams. Roughly one third of the pre-LS1 busbar splices had to be unsoldered due to electrical or geometrical non-conformities. All those splices had re-soldered with improved quality.

With the end of the consolidation activities, the operations team's attention turned to preparing the LHC for beam commissioning which, after some delays, eventually started in April 2015.

The operations team took a leadership role in the powering test phase. Here each of the magnet circuits was put through a rigorous program of tests to ensure nominal electrical behaviour, and proper functioning of all related systems such as power converters and the quench protection

system. The operations team not only coordinated all tunnel activities, but performed shifts dedicated to performing the many thousands of requisite tests. This program was performed sector by sector following the phased cool-down the machine and culminated in the quench training for 6.5 TeV operation. All this in very close collaboration with magnet and machine protection specialists.

In parallel with the hardware commissioning program, there was a concerted series of system tests and dry runs designed to fully check the performance of all other systems. These ranged from RF, controls, timing, injection, beam dump, collimation and beam instrumentation. The tests were performed from the control room in close collaboration with the equipment groups concerned. The success of the eventual beam commissioning was in large part thanks to the painstaking effort put in at this stage to debug and fully prepare the critical beam related systems.

## **BE-RF [Group](#)**

The LHC was stopped in 2014, which allowed for maintenance and for the implementation of improvements. In the surface building SR4, the enclosure to shield the LLRF equipment from variations of the ambient temperature was completed including the installation of a dedicated air conditioning system. For the transverse damper system ADT, the replacement of PU cables and the installation of eight additional PUs was completed on time. The eradication of PowerPC CPUs and LynxOS in LHC was completed, with all VME crates migrated to Intel CPUs and all front-end software ported to Linux. Upgrades included the production of a new signal processing board, which was prepared to run with FESA 3, featuring 4 individual DACs with their outputs combined, allowing for easy programming of individual gain control for cleaning and blow-up applications as well as different gains for witness bunches and main beam bunches, found to be indispensable to permit good tune measurement.

The new LHC observation box project was launched with the aim of providing a system to acquire the gigabit streamed data from the longitudinal pickups and transverse damper VME modules into a Linux PC and make it available for fixed displays and offline analysis. A prototype system was integrated using a rack-mount server containing SPEC (Simple PCI Express FMC Carrier) boards and device driver from BE-CO and custom software to handle signal streaming into the PC and serve the data to clients. Tests were performed demonstrating that it is feasible to extract tune spectra at the maximum rate (3 Hz) using only the CPUs, although the design allows the possibility of using a GPU for more complex signal processing if required.

Before LS1, the ADT tetrodes were found to have a short lifetime. A careful study of the system showed that tetrode characteristics had changed since they had been in operation in the SPS 10 years earlier. The lack of cooling was found as most likely culprit, and after careful validation tests in the test area of building 867, new air and water cooling of all 16 ADT amplifiers were deployed in the LHC tunnel (cf. Figure 6).



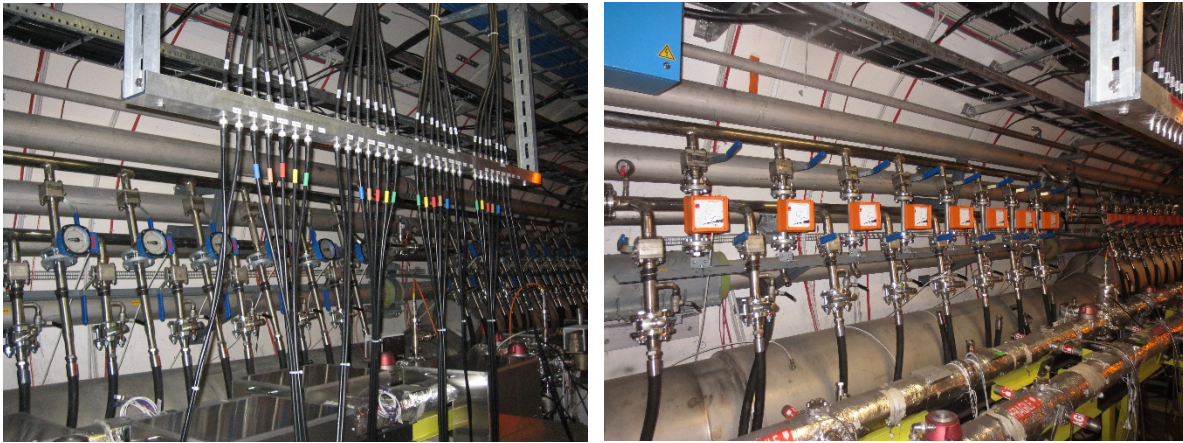

**Figure 6: Modernisation of the LHC ADT water and air cooling; Top: Insufficiently small turbine on the left before intervention and new ADT blower to cool tetrodes on the right. Bottom: Old LEP type flow meters generating false alarms frequently on the left and new water distribution system on the right.**

For the LHC high-power system, significant improvements could be implemented on the high voltage connectors of the sixteen 300-kW-klystrons. A dedicated inductive welding machine and an adapted procedure was developed. More than 100 connectors in total were successfully repaired/improved as illustrated in Figure 7. The electrical perturbations induced by these damaged connectors were one of the most important cause of RF trips during LHC run 1 – significant improvement is expected in run 2.



**Figure 7: Improvements of the LHC HV connectors; from left to right: a view of the connector, the x-ray of the connector before intervention showing voids in the weld, the induction welding coil, the x-ray of the repaired connector.**

In order to further improve the reliability of the RF system, a new klystron fast protection (crowbar) system, based on solid state technology, was developed and implemented in LHC.

A particle tracking code called BLoND (Beam Longitudinal Dynamics) was developed for the simulation of the LHC controlled longitudinal emittance blow-up during the acceleration ramp. Although the blow-up works fine with operational beams, unexplained bunch evolution was observed during several MDs. BLoND will allow to reproduce this behaviour, help us understand it and thus hopefully improve the operational blow-up.

At the IPAC'2014 Conference, a prize for a student registered for a PhD or diploma in accelerator physics or engineering was awarded to Juan Esteban Muller (BE-RF & EPFL) for the

work “High-accuracy diagnostic tool for electron cloud observation in the LHC based on synchronous phase measurements“. Juan developed this operational tool available from CCC, which will be particularly helpful for the LHC scrubbing runs.

Another significant event was of course the swap of the ACS cryomodule “America”, also known as “M1.B2”, in which 1 of the 4 cavities does not reach the nominal 2 MV acceleration voltage, by the spare module “Europa” after careful validation of its performance.

## **High Luminosity LHC (HL-LHC) – LHC Upgrade**

### **BE-ABP Group**

During 2014 efforts have been focussed in the optimization of layout and optics of the high luminosity interaction regions IR1 and IR5 taking into account the updated design of the magnets (in particular those of the matching section), the results of the energy deposition and collimation studies and the constraints resulting from the integration of the components in the tunnel. A new layout and optics (HL-LHCv1.1) have been released and published in the optics repository.

The operational cycles for all the magnetic elements of the machine have been devised and optimized and the corresponding powering schemes have been defined to allow the specification of the characteristics of the power converters for the new magnetic elements including noise levels, reproducibility and accuracy.

The work towards the specification of the magnet and field quality specifications for the new IR magnets and for the 11 T dipoles has continued in an iterative process with the magnet builders and considering realistic operational scenarios including chromaticity, Landau octupole settings and the effect of beam-beam. The requirements in terms of field quality on optics measurement and correction strategies are being estimated based on the experience of Run I.

Based on the experience gained in 2012 and the models developed to include the combined effects of impedance, beam-beam, Landau octupoles and transverse feedback on beam stability an operational scenario has been defined and limits on the impedance on the new components to be installed have been specified. Particular care is taken in the analysis and steering of the crab cavities’ impedance in collaboration with the teams responsible for their design. As part of the study of the possible intensity limitations the heat load on the beam screen resulting from electron cloud, image currents have been provided to the cryogenics team for the specification of the new cryogenics installations and the evaluation of the available margins for the existing installations.

The study of the beam-beam effects has confirmed the feasibility of the nominal scenario based on the  $\beta^*$  levelling mechanism (see Fig. BB) providing sufficient operational margin for operation at the ultimate luminosity of  $7.5 \times 10^{34} \text{ cm}^{-2}\text{s}^{-1}$ . In parallel, the analysis of the compensation of beam-beam long-range effects by means of wires or electron beams is being pursued together with the definition of the beam conditions and measurements that needs to be done with wires embedded in tertiary collimators to be installed in the LHC during the year end technical stop 2016-17.

Most of these results have been documented in the HL-LHC Preliminary Design Report.

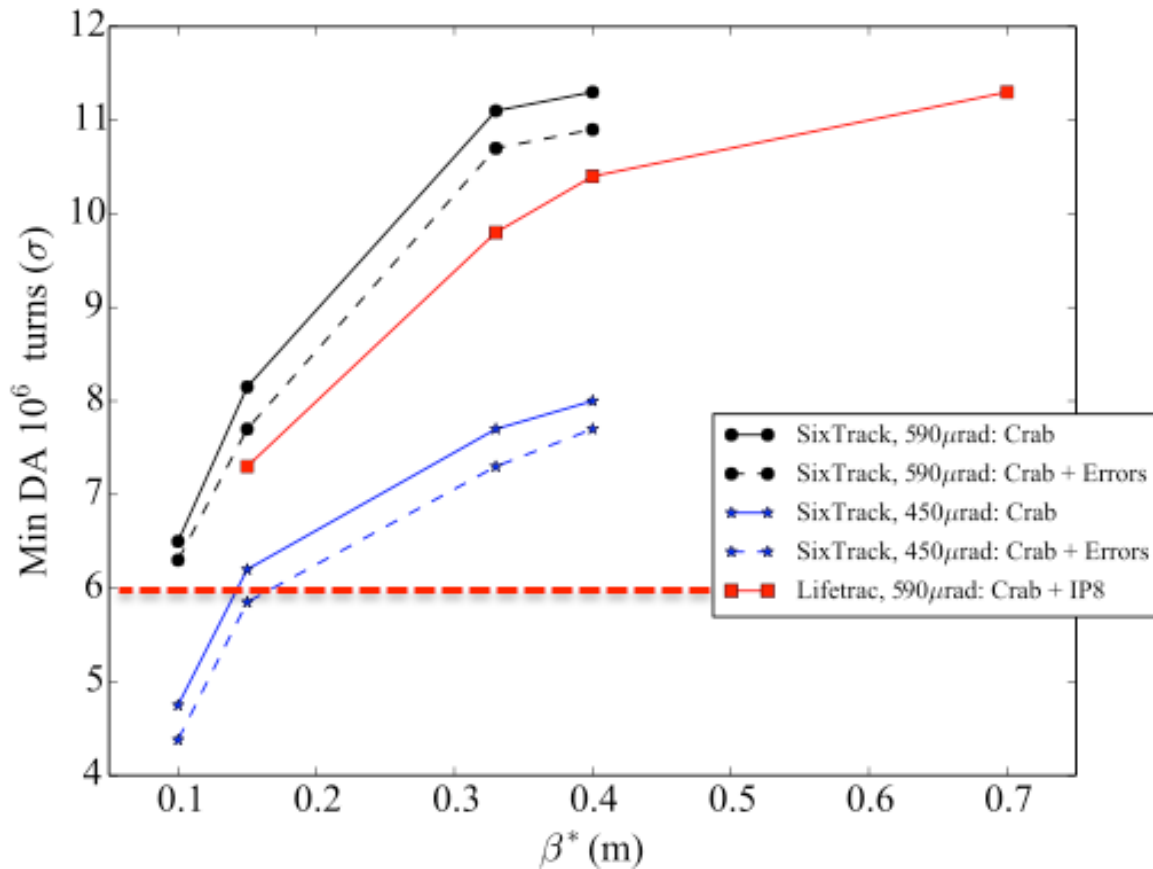

Figure 8. Minimum dynamic aperture in the presence of beam-beam effects for the nominal scenario with  $\beta^*$  levelling (black) in IR1 and IR5. The effect of the collisions in IP8 (levelling by separation) is also considered (red). A case with a reduced crossing angle is considered too (blue). The effect of magnetic field errors is represented by the dashed curves.

## BE-BI Group

### Beam-Gas Vertex Detector (BGV)

The components for the modified vacuum system for the BGV were manufactured, assembled, tested and successfully installed in the LHC on a very tight schedule during the first 6 months of 2014 (Figure 9). This included a mechanically highly optimised aluminium ‘window’ to allow secondary particles from beam-gas interaction to pass from the vacuum system to the external detectors seeing the minimum of material. Extensive electro-magnetic and thermal simulation was also performed on this structure to verify the impact of impedance and RF heating.



**Figure 9: The prototype beam gas vertex detector vacuum system installed in LSS4 of the LHC.**

### Interaction Region Beam Position Monitors

The design of stripline BPMs for the new triplet in IP1 and 5 has been launched. Most of the pick-ups will be inserted into the interconnection between magnets. Two possible mechanical designs are under study, one with a circular geometry and the other with an octagonal cross-section as shown in Figure 10. The BPM is connected to the octagonally shaped beam screen on one side and to the plug-in module on the other side.

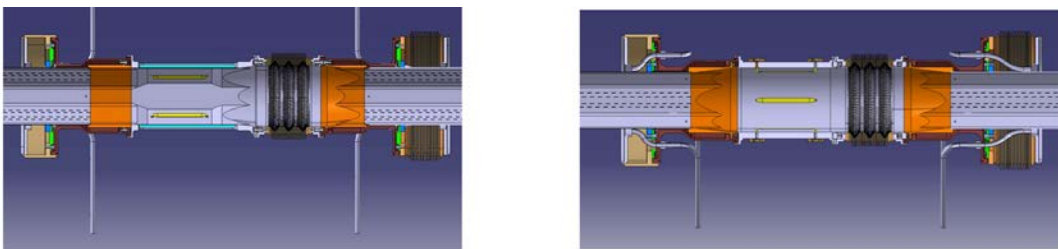

**Figure 10: HL-LHC Triplet Stripline Pick-up. Left - with an octagonal cross-section. Right - with a circular cross-section.**

Improving the directivity of the stripline is essential for improving the final position measurement in these BPMs that observe both beams. This has been studied in detail using RF simulations performed with CST Particle Studio. Several configurations (see Figure 11), have been tested, all highlighting the fact that the transition from the stripline to the electrical feedthrough is one of the most critical parts of the design.

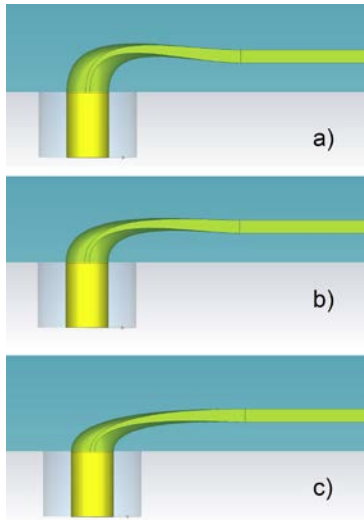

**Figure 11: Three possible stripline transitions. (a) has a better directivity compared to (b) and (c).**

A comparison between the directivity of the current LHC stripline BPM and an optimized geometry is presented in the table below. An improvement of 7-10dB, depending on the bandwidth considered, has been demonstrated in simulation. The next step is to turn this into a mechanical design with all the constraints of a cryogenic BPM.

Frequency [MHz]	Directivity	
	Current BPM [dB]	New BPM [dB]
100	27	34
200	28	34
500	24	30
1000	14	24

## BE-RF Group

### Crab Cavities

Three prototype crab cavities built in collaboration with US-LARP and UK were all successfully tested to nominal kick voltage of 3.4 MV or beyond (up to factor 2) in SM18.



4-rod cavity (U Lancaster)



RF Dipole (ODU/SLAC)



DQWR (BNL)

**Figure 12: Nb prototypes of the three crab cavity designs, fabricated by Niowave Inc. in the frame of the US-LARP collaboration.**

In May 2014, the cavity, cryomodule and RF system designs were subject of an important international expert review. Only two cavity types were recommended to proceed, namely the RF Dipole and the DQWR. The key milestone to freeze the cavity designs and interfaces was met shortly after, and fabrication of bulk niobium cavity parts needed for the SPS validation tests started with the help of EN-MME. He-vessel, HOM couplers and magnetic shields were designed, some critical parts prototyped for the validation of design choices. Mechanical and thermal calculations of the cavity support, tuners, thermal shield, outer vacuum vessel and alignment system progressed to finalize the cryostat design. Significant progress was made in collaboration with EN-MME on the engineering design of the two dressed cavities, and a conceptual design of a two-cavity cryomodule for the SPS tests was finalized; it will also be the basis for the LHC implementation.

The FPC (Fundamental Power Coupler) design (cf. figure 13) aimed at having the same coupler for either choice of cavity – except for the coupling element. The now robust FPC design features a water-cooled inner conductor and conical line for better power performance, allowing for a large window with forced air cooling. A vacuum gauge is mandatory both during processing and operation of the coupler, since cryo-pumping by the cavity would mask any fault inside the coupler. A DC polarisation has also been designed in case it is needed suppress multipacting.



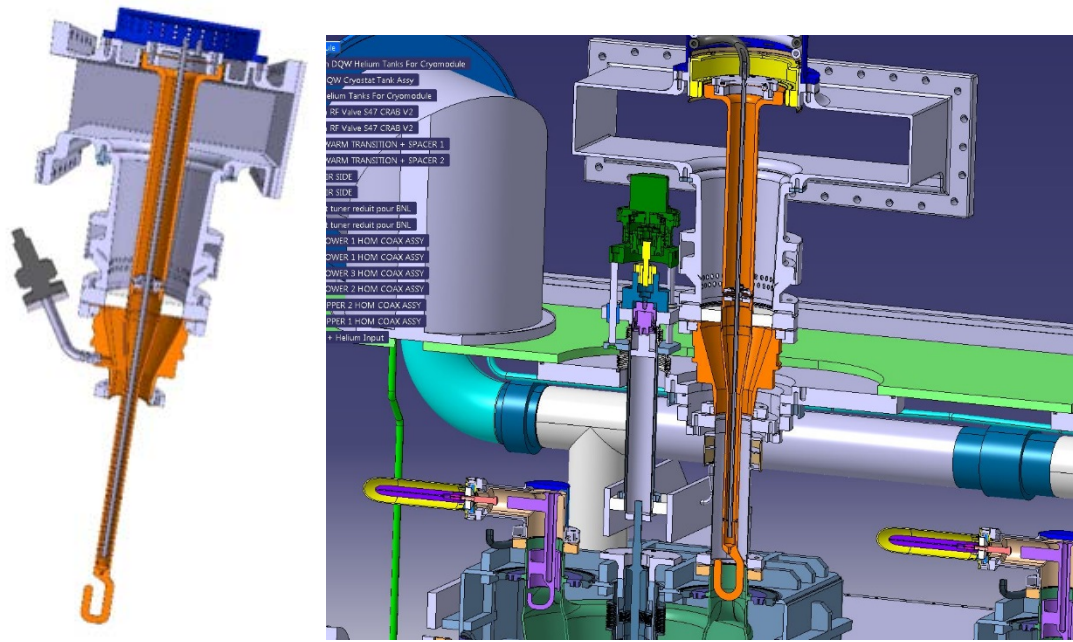

**Figure 13: Design of the Crab Cavity Fundamental Power Coupler (FPC) fitting both cavity types (left) and its integration in the cryomodule (right).**

The RF architecture, both high and low power, were defined to launch the integration studies of the LHC interaction region. A detailed roadmap to follow the fabrication and installation in the SPS was prepared and good progress was made on different fronts to meet the deadline to perform SPS tests before LS2. Complementary studies on crab cavity voltage optimization, aperture, impedance, machine protection studies and RF noise were carried out to finalize the specifications.

Transverse emittance growth caused by RF noise is a major concern with the LHC crab cavities since this would reduce the luminosity lifetime. Significant progress has been done on the topic: Theoretical studies, using a statistical signals approach, of the transverse emittance growth due to RF CC noise, without and with transverse damper, were conducted. Unlike previous studies (KEK), this work considers both phase and amplitude noise and does not use short-bunch approximation. The calculations have been checked with simulations using the PyHeadTail tracking code – the agreement is excellent. First results have been presented at the 4<sup>th</sup> HiLumi-LHC/LARP meeting at KEK, in November.

### Harmonic Cavities

Studies on both higher harmonic (800 MHz) and a lower harmonic (200 MHz) RF systems were carried out to identify the technological challenges for the various modes of operation. A realistic baseline for a 2<sup>nd</sup> harmonic system at 800 MHz with 2-4 cavities per beam in the bunch shortening mode was proposed with the main motivation of providing longitudinal beam stability with HL-LHC beam currents exceeding 1.1 A. A first integration study was performed to determine the envelope constraints for the cryomodule in Point 4 of the LHC and found feasible.

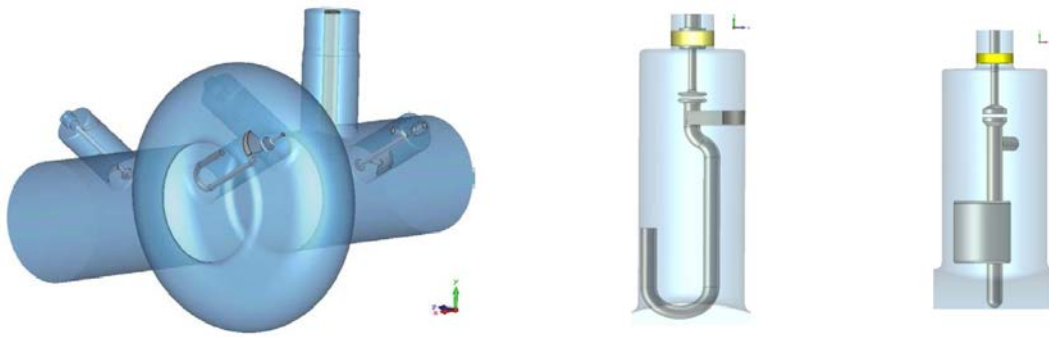

**Figure 14: Cavity (left) and HOM coupler designs (right) of the harmonic cavity for the LHC at 800 MHz.**

A sub-harmonic system at 200 MHz as a potential main RF system for the LHC was studied with the main aim of reaching intensities beyond the HL-LHC while retaining the present 400 MHz RF system as harmonic system.

### **Transverse Damper upgrade**

An outline of a possible upgrade of the transverse damper system to include new kickers to cover more bandwidth was worked out in 2014. In this respect the work for the SPS Wideband feedback System is essential in order to prototype kicker structures relevant for the LHC upgrade and gain experience before a system is proposed for LHC. The upcoming run 2 of LHC will ultimately show if transverse instabilities are limiting the performance and to what extent the roll-out of an upgraded or new feedback system can be a remedy for these.

## **LHC injector chain (Linac 2, Linac3, PSB, LEIR, PS, SPS, Experimental Areas and Associated Facilities)**

### **ABP Group**

#### **Linac2**

Linac2 was the first of the CERN accelerators to start up after the long shutdown. The Linac itself had not undergone many hardware changes (only the beam instrumentation in the transfer line had been replaced, in readiness for the future connection of Linac4), but it was nevertheless a strong test bed for changes to the control systems that had happened in the previous year. The restart was difficult and sometimes exhausting and involved all the experts from the different equipment groups, with the beam being delivered in the beginning of June to the PSB. Many lessons were learned which will be improved in the future for restarts after long stops.

For the rest of the year the linac was running quite reliably. Minor problems were fixed with as little delay as possible, and a total of  $2.7 \times 10^{20}$  protons were delivered to the PSB during the year.

## PSB

The first semester of 2014 was dedicated to finalize the analysis of data taken during the MDs before LS1 and to prepare the restart of the machine, in June.

ABP participated to the long re-commissioning after the startup and contributed to the beam performance optimization, which could finally take place only toward the end of the year. Indeed during LS1, a lot of work and changes have been done, including a new Digital LLRF system, new instrumentations and controls which made the PSB an almost new machine.

In particular, during LS1 the PSB magnets were completely realigned, with the idea to remove all the voluntary offsets introduced along the years, to correct for Closed Orbit Distortion, and to use for the correction the steering magnets only, equipped with the new FGC3 power converter controllers. This strategy proved not to be enough, leaving large orbit excursions which induced hot-spots in the machine, and few magnets had still to be moved. ABP played a key role to define the minimum set of displacements in the tunnel and in computing the best set of orbit correctors to be powered to finally reach a Closed Orbit control within  $\pm 1$ mm in the four rings.

ABP contributed to the commissioning of the new BLM system and electronics, which will allow for more detailed measurements of beam losses along the cycle, and to the Turn-by-Turn position acquisition system, in preparation for the optics studies, also planned for 2015. Furthermore, some Machine Development studies could already take place toward the end of the year, which brought new understanding of the interplay between chromaticity, space-charge and resonances.

## PS

The dummy septum needed for the multi-turn extraction (MTE) as a mitigation means of beam losses during the fast bump rise time has been fully commissioned and put in operation. All fast extractions from PS have been reviewed and made compatible this new device, which is installed in straight section 15. In order to cope with the reduced mechanical aperture due to the presence of the dummy septum blade, the fast extraction schemes include now optimized slow bumps for all cases except the LHC beams. Also the fast bumps have been made more complicated by adding some of the kickers originally envisaged only for MTE operation. This also led to a reduction of the extraction losses for operational beams, such as TOF.

During LS1, two new electron-cloud monitors were made available in the beam pipe of a main magnet unit. These detectors should observe for the first time the electron cloud forming during the LHC beam extraction process, in a combined-function magnet. One is a normal pickup, while the second detects the photons generated by the electrons.

On the theoretical side, progresses on some collective effects limiting the machine performance have been achieved: space-charge studies brought new understating of the interplay between beam- and lattice-induced resonances; the long-standing issue of the intra-bunch beam oscillations observed during the first turns was explained by the combined effect of indirect space charge and large injection errors; the longitudinal and transverse impedance models have been further developed.

The shielding on top of the Route Goward and the extraction region 16 was significantly increased according to the new RP requirements.

## Linac3

Linac3 provided an argon ion beam to set-up the accelerator chain up to the SPS. The beam will be used in the first quarter of 2015 for the fixed target experiment NA61 to study phase transitions in strongly interacting matter (quark-gluon plasma).

Out of the Linac pulses of  $5 \times 10^9$   $\text{Ar}^{11+}$  ions were delivered in 200us pulses for each LEIR injection, the charge state having both a similar rigidity to the normal lead beam, and is within reach for direct production from the source, meaning that the ions did not require stripping before injection into LEIR.

This ion beam is not very demanding with respect to intensity, but does cause significant damage to the low energy parts of Linac3, due to the high ionization and sputtering rate of argon. Several parts of the source had to be exchanged after about 4 months of running, where they showed considerable visual deterioration.

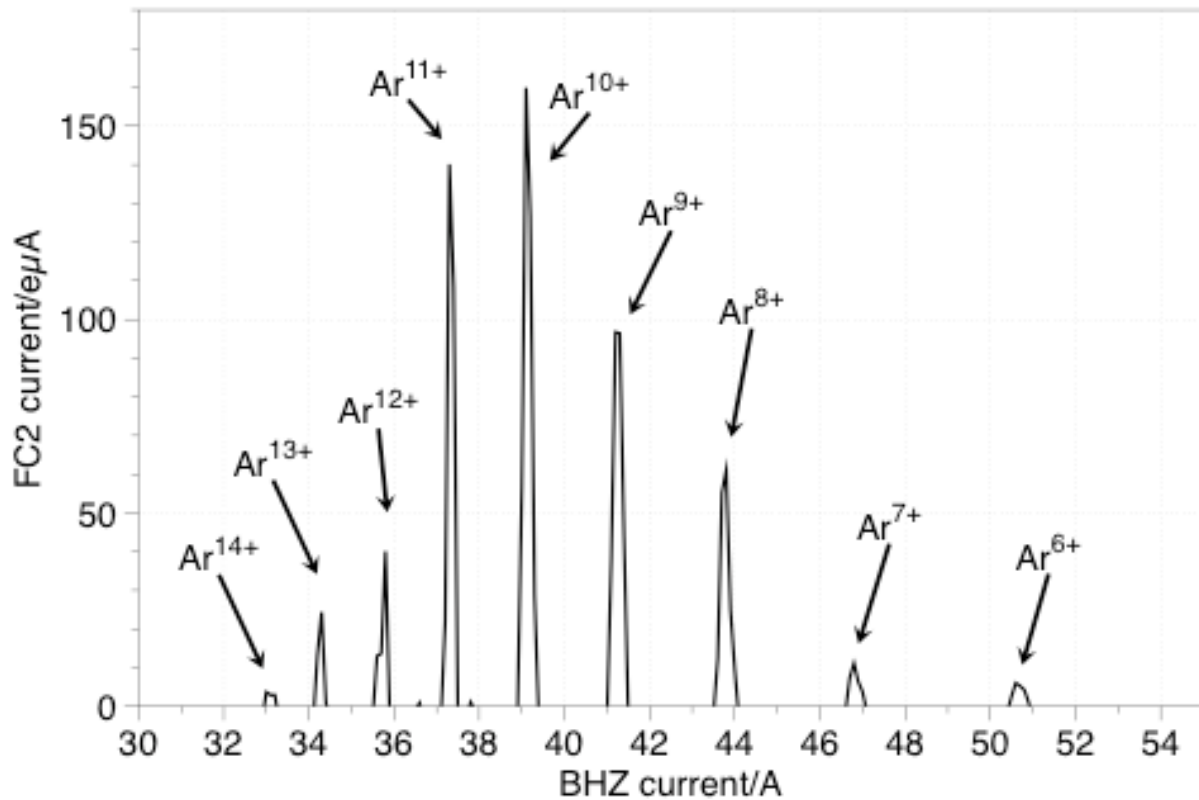

Figure 15: Charge state distribution after the GTS-LHC ion source.  $\text{Ar}^{11+}$  is accelerated in Linac3 and delivered to LEIR

## LEIR

The new ion species still represented a challenge by requiring a different LEIR setup due to the slightly higher charge-to-mass ratio than  $\text{Pb}^{54+}$  (the last ion species from 2013). For the argon ions to the North Area, the priority was a stable intensity from shot to shot, rather than maximum intensity. From LEIR, after a single multi-turn injection and subsequent electron cooling, up to  $3 \times 10^{10}$  charges in a single bunch were extracted to the PS. However, optimal stability was achieved with slightly less than  $2 \times 10^{10}$  charges in a single bunch. LEIR has delivered the ion beam always within the limits of emittance specifications, which are more relaxed for ions to the fixed target experiments when compared to LHC.

In order to improve the basic understanding of the complex LEIR machine, a special effort was dedicated to find a the bare machine setup, within which the argon ion beam is manipulated with just the main bending magnets, the injection dipoles and the five main quadrupole families powered, and specifically, the electron-cooler switched off.

## BE-BI Group

The first half of 2014 saw the progressive closure of the LHC injector chain in preparation for re-commissioning. Final BI installations followed this progress. Many installations were scheduled close to closure dates for ALARA reasons. Replacement of the PSB beam dump, re-installation of the SPS LSS1 following de-cabling and the renovation of the North area target zone (TBIU/TBID) were all sector-wide projects requiring significant BI participation that had been scheduled at the end of the shutdown to allow the maximum time for these regions to cool-down.

### BI Operation during 2014

Following the changes made to mechanics, electronics and BI software on many systems in the PS complex, the 2014 restart was very time consuming. Prior to start-up with beam, several dry-runs were organised per accelerator starting with LINAC2 in late March 2014. Similar BI-related dry-runs were later organised for the other facilities including LINAC3, PSB, LEIR, PS and finally SPS including the instrumentation in TI2 and TI8. The principle was in all cases the same: identifying the operational clients of all systems in collaboration with BE/OP and the software layers required in coordination with BE/CO, and making sure that all issues identified were understood and resolved. Additional efforts were required for the upgraded BPM, BCT and SEM-grid acquisition systems in the PS complex, to deal with settings handling in the new INCA framework. In general, most issues were quickly identified and resolved while some could only be observed with beam, such as, for example, an issue with a BCT in the PSB measurement line, where oscillations affecting the measured signal led to the need to replace the detector with a spare.

20 magnetic Beam Position Monitors (BPM) of the LINAC2 and Booster injection transfer lines, dating from the seventies, were upgraded in early 2014 (see Figure 16). The new stripline BPMs are of the same type as foreseen for LINAC4, although the operating RF frequency is different.

**Figure 16: a picture of a new stripline BPM on the LINAC2 to PSB beam-line**



The BPM acquisition system is based on analogue down mixing of the bunch signals at 202MHz to baseband followed by digital I/Q sampling. The main functionality of the new system is beam

position measurement, but the system has also been designed to measure the energy of the beam via Time-Of-Flight between two BPMs. The new system was commissioned with beam during the spring, giving good results (Figure 17).

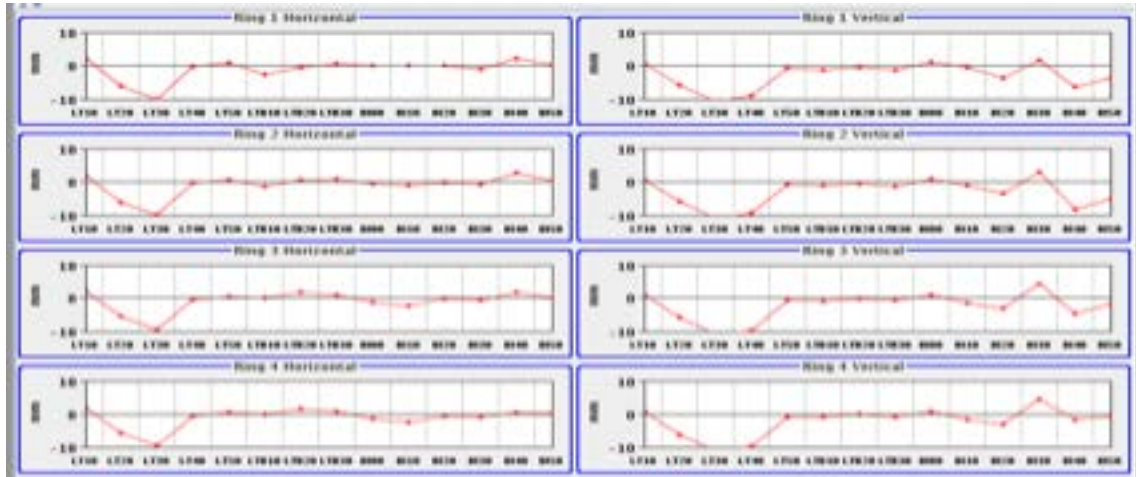

Figure 17: A view of the average H and V positions of the beam to be injected into each PSB ring

A new development for providing an on-line beam size measurement system as electron-cooling diagnostics for AD/LEIR saw good progress during 2014. For the first time it was possible to clearly measure the cooling effect along the LEIR cycle with the new ionisation profile measurement system as can be seen in

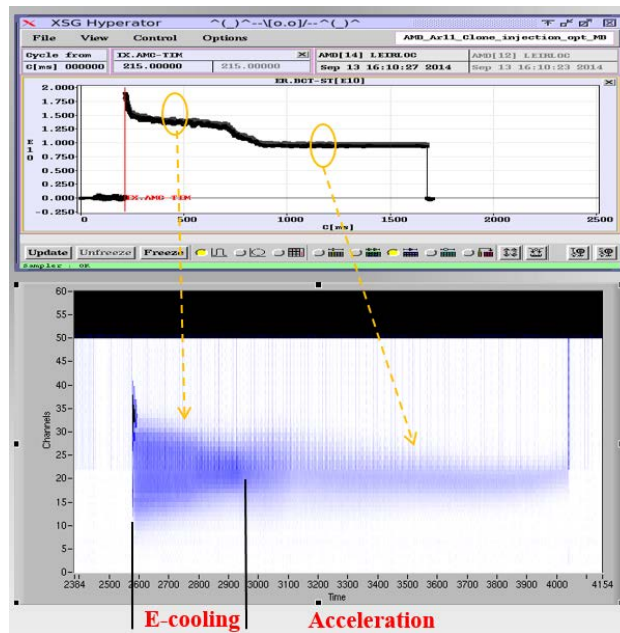

Figure 18: Top - beam intensity during the LEIR cycle. Bottom - relative beam size during the same cycle.

In the SPS, the BI Group was involved for the first time in a personnel protection system aimed at preventing high beam intensity extraction to primary fixed-target experimental areas of the SPS during lead ion running. The human protection aspect had major implications on the implementation and testing as the system must be failsafe and perform self-checks at regular intervals. Several iterations were required before the specifications could be approved by all parties involved and the electronics and software correctly tested with beam.

## BE-CO Group

### The InCA/LSA project

After the important consolidation work carried out during 2013, a significant part of 2014 was dedicated to the recommissioning of the InCA/LSA software suite on all accelerators. This includes many individual tests performed by the InCA team together with dedicated users and FESA class providers, and a series of vertical integration tests from the hardware level up to the InCA applications in the frame of the dry runs campaign organized by BE-CO.

All equipment types renovated during LS1 have been reconfigured to be properly processed by the system and displayed by the InCA generic applications using a newly developed configuration tools.

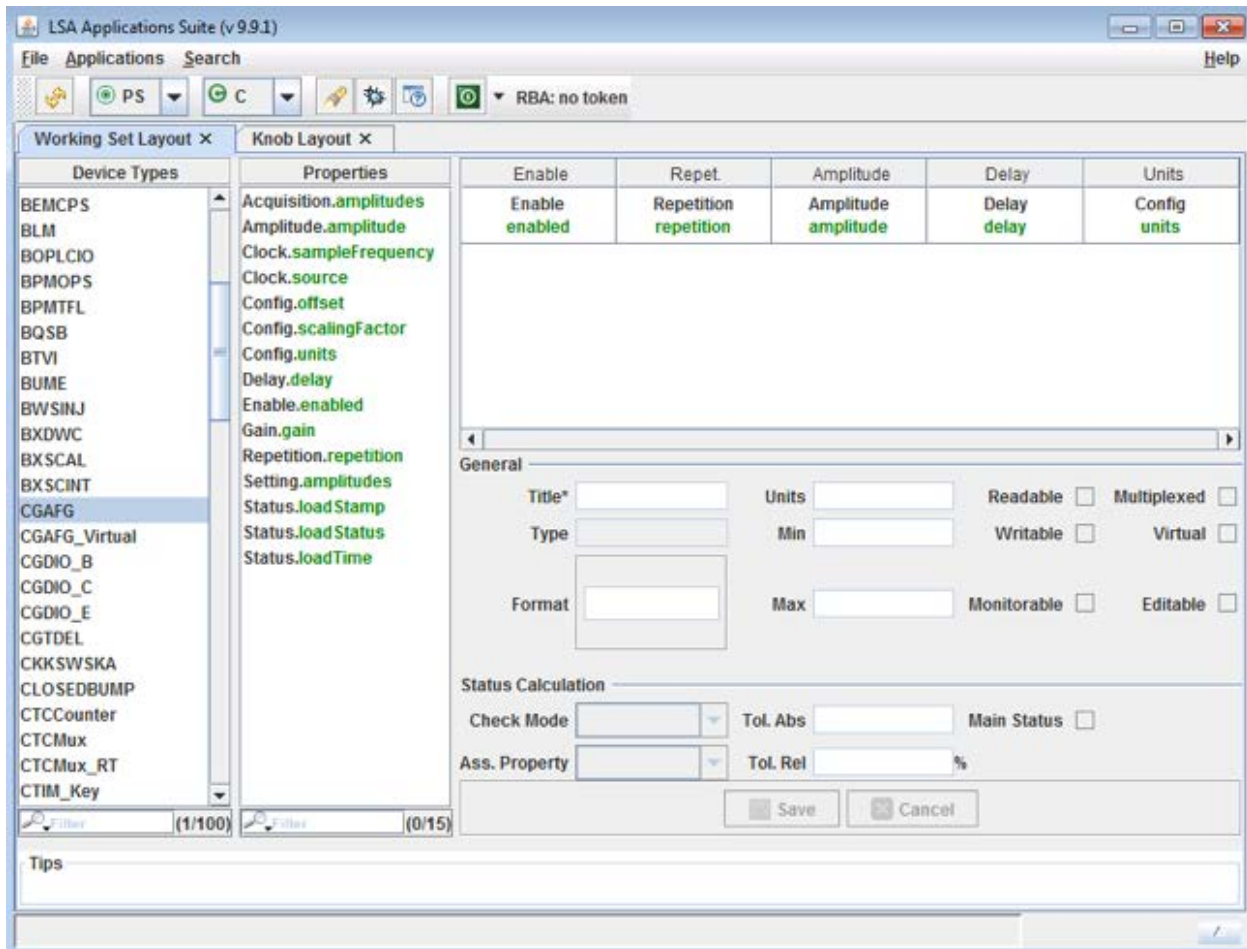
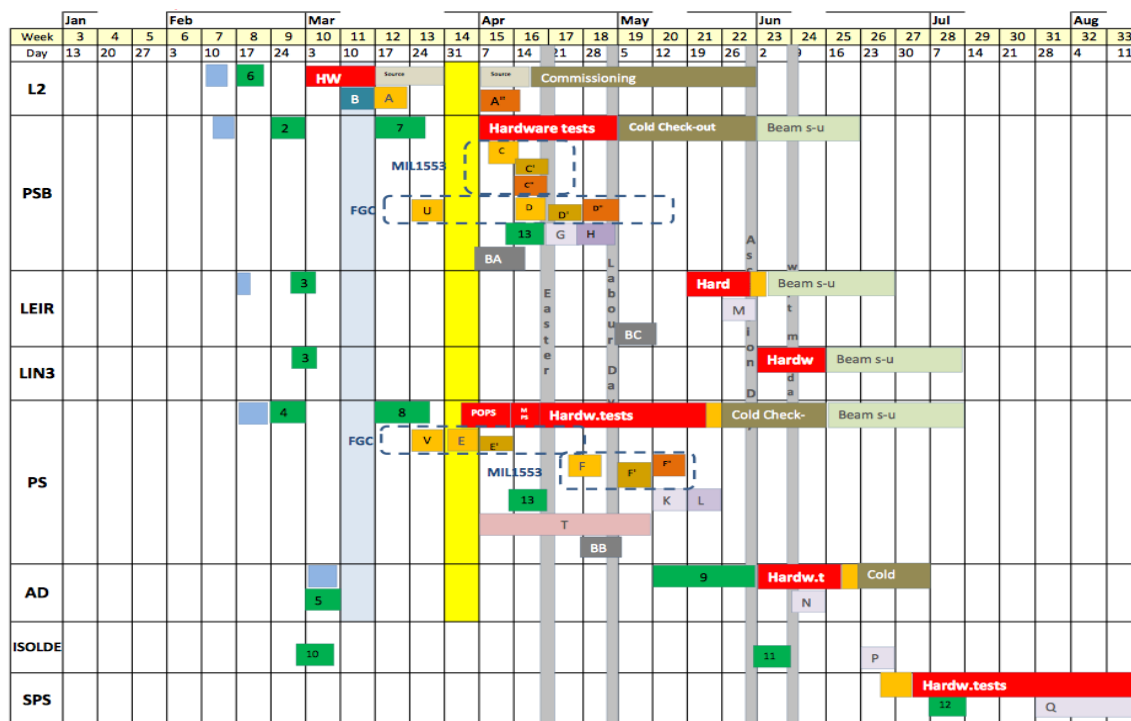

Figure 19: New Working Set configuration tool

### The ACCOR Project

The ACCOR project started in 2009 and went to completion in 2014. The last but crucial phase of the project was the re-commissioning of the full control system vertical stack after the massive hardware and software re-engineering effort of 2013 (about 450 front-end systems). Experts from all controls disciplines were mobilised around this key objective during a period running from March 2014 until September 2014. Over fifty DRY-RUNS were carefully planned and

organized in close collaboration with operations and with all equipment groups. Thanks to this solid organization and collective effort run from the CCC and on the field, the entire Injector complex did restart without any significant perturbation. The injectors 2.0 infrastructure is now in place hardware and software wise, ready to serve the forthcoming LHC challenges.



## Hardware FrontEnd Platforms

In Linac 3 and LEIR the migration of the hardware base took place from LynxOS PowerPC Single Board Computers to a new platform based on Intel processors and running Linux. This effort was accompanied by the migration of GM and FESA2 classes to FESA3.

## BE-OP Group

### PSB

The start-up of the PS Booster after LS1 was a special challenge, given the large amount of changes done during LS1. The main interventions potentially impacting the start-up were the implementation of a new, digital RF control, the upgrade of diagnostics (BLMs, orbit, BPMs and BCTs in the transfer lines), the renovation of the multipole power supplies, installation of a new main dump, installation of additional 5 prototype Finemet cavity cells, controls upgrades (change of many FECs) and the consolidation of lifting equipment. Some limited cabling work and related civil engineering was also done.

Despite the large amount of interventions, the PS Booster had a rapid start-up after LS1. A first beam of  $4E10$  protons was injected in ring 3 on 2<sup>nd</sup> June. The same afternoon small intensity could be accelerated in all 4 rings.

This rapid first injection was followed by a setting-up phase in order to recover the full beam specifications as from before LS1. A special effort was made by the low-level RF team to commission the new digital low-level RF control, which is by now fully operational. Also the control system was re-commissioned smoothly, taking into account that 90% of the front-end



computers had been renovated during LS1. The good preparation work with dry runs during the last part of LS1 and the check-out phase, and the good support during the start-up paid off.

The Booster could hence deliver its first user beams to the ISOLDE, TOF, EAST Area and AD as scheduled. Setting up of the LHC-type beams started also rapidly.

## PS

Early 2014 the staff that run the PS and that were re-distributed to perform LS1 related tasks returned to re-commission the PS, its transfer lines and associated experimental areas. After the commissioning of the new PS Complex access control and safety system all PS equipment was re-commissioned through hardware commissioning and dry runs. The latter formed a cornerstone activity for successful controlling the machine following the renovation of the controls system and the deployment of many new FESA classes and high-level software.

By 23<sup>rd</sup> May the hardware commissioning was wrapped up and the PS operations team started the cold check out of the entire machine, switching on all equipment fully loading the control system, cooling system, etc. in order to setup the PS in the most realistic conditions possible, with the aim to identify remaining issues before injecting beam."

The injection of beam on 20<sup>th</sup> June marked the definitive end of LS1 for the PS, but also mean the started of an intensive period of setting up of the different beams and to regain the pre-LS1 performance.

On July 15<sup>th</sup>, according to schedule, the first physics beam was successfully send to the East area users. Soon after that the single high intensity bunch was send to nTOF where it was used to commission of the new experimental area EAR2. The AD beam followed and also substantial effort went into preparing the different types of LHC beams with the aim to re-establish the pre-LS1 performance, but also to prepare more special beam such as the doublet scrubbing beam that was extensively and successfully tested and used during the different SPS scrubbing runs. In parallel the PS was setup with Argon ions in view of the physics run in the SPS North Area early 2015.

On Monday 15<sup>th</sup> December the beam stoppers were closed again for the short year-end technical stop. The 2014 run allowed the PS and its team to iron out most of the wrinkles left from LS1 and to be in good shape for the 2015 restart with the LHC requiring different high-quality beams.

## SPS

During LS1 the SPS underwent major modifications on various systems. The main power supplies were equipped with new 18 kV transformers, new 18 kV cables, firing cards and thyristor racks. The control software ROCS for the SPS power converters was replaced by FGC software as used for the LHC power converters. The timing system was adapted to fully exploit the new functionalities with FGC. In particular, the handling of the SPS COAST could be significantly simplified and an all-encompassing economy mode for the SPS power converters was implemented. The SPS RF system was equipped with a new power and low-level control. One SPS sextant was realigned with a vertical shift of up to +4 mm. All of the long straight section LSS1 was de-installed for a campaign to replace radiation damaged cabled, and the TT10 tunnel had to be consolidated and re-installed again afterwards. In addition, the splitters and collimators in TDC2 were de-installed for re-cabling.

The SPS crew started dry-running the new timing system and the FGCs from March 2014. The end of the SPS LS1 tunnel activities was only planned for 27<sup>th</sup> of June, when the machine was closed to prepare for the mains hardware tests. The summer months were spent testing and preparing all tools and systems for beam operation in parallel to the hardware tests.

An inspection of the SPS high energy internal beam dump before re-connection in LSS1 revealed beam induced damage of the Al section of the dump core. Continuous dumping of CNGS beams was deduced to have been the cause of the damage, from analysis of operational data over the past decade. The dump was replaced with the operational spare of the same design, but power load limits and restrictions for LHC beam setting-up had to be put in place to avoid similar damage. To ensure the protection SPS OP prepared a software interlock to limit the power onto the beam dump for the start-up.

First proton beam was foreseen for 8<sup>th</sup> of September, but the high voltage conditioning of the injection and dump kickers took longer than planned after LS1, as a consequence of earlier delays in cooling water availability. The first beam was therefore late by a few days, but physics start-up for the North Area was on time on 6<sup>th</sup> of October.

The SPS had to start up with proton fixed target beam as well as LHC 25 ns beam 12 bunches, in order to optimize the beam-based quadrupole alignment for both beams simultaneously. Until Christmas the SPS successfully prepared the pilot beams for the LHC transfer line tests, executed two scrubbing runs and started commissioning the fixed target Argon beam for the NA ion run in 2015. Another highlight was the successful preparation of the LHC scrubbing “doublet” beam.

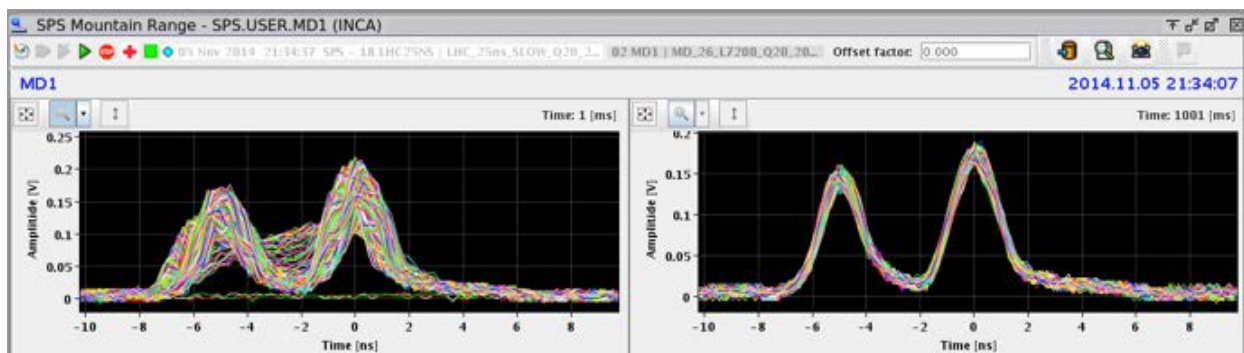

Figure 20 : The doublet beam generated at SPS injection during the first splitting attempts.

## BE-RF Group

### PSB

The 2014 start-up of the PSB was challenging since a new digital LLRF system was to be commissioned with beam. The previous system had been preserved in case of unforeseen problem, but fortunately all beams could be set up with the new system on schedule. This is due to its flexibility made possible by the versatile hardware that can be easily switched by software between cycles and configured optimally for the different beams to be controlled. All three cavity systems in the four PSB rings are controlled by this new system since the 2014 start-up. The PSB LLRF system hardware is also used for MedAustron (see below) and has been chosen by BE-BI for use in the new AD and ELENA orbit measurement system.

Figure 21 shows the layout of the system with one VME crate per ring complemented by a development system “Ring 0” in a separate crate that can be fed with actual signals and serves both to test modifications before deployment on the operational systems as well as to control the Finemet® prototype cavity system (see below). It shows equally sample traces from the internal diagnostics, as they are available to the operators and experts to diagnose problems, both inside the RF system and within the accelerator. Implementing these embedded diagnostics represented a major effort and adaption to the needs of operations continues in 2015. The image of the

mountain range of the bunch splitting process shows how the two RF systems C02 and C04 can be controlled to obtain a splitting with minimized losses.

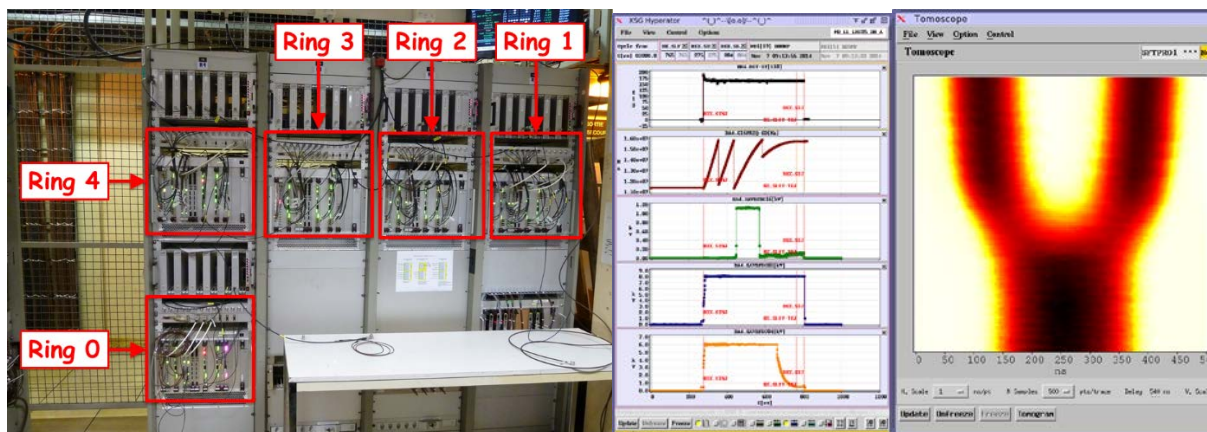

**Figure 21: PSB Faraday Cage Layout of new digital LLRF system (left), traces of voltages, frequencies and intensities by embedded diagnostics (centre) and mountain range plot of a bunch splitting process (right).**

## PS

Equally the PS start-up was complicated due to commissioning of a new, all-digital 1-turn-delay feedback system on the 10 MHz system, which was installed and commissioned jointly by the low-level and power teams in the framework of the LIU project. It was set up for various different beams and reduces as foreseen the transient beam loading. As an example, (figure 22) shows the batch compression in the PS used for the AD anti-proton production beam. Without feedback (left), particles are lost from the buckets and bunches are seen to oscillate on the mountain range display. With feedback (right) stability is restored, beam loading reduced and a clean batch compression is obtained. The new 1-turn-delay feedback hardware also contains the control loops for the cavity amplitude (AVC), which can now be programmed with different parameters for different beams thanks to the digital implementation. Thanks to this change, also the so-called “10 MHz matrix” is now replaced – the digital implementation was equally commissioned during start-up and promises to be much more flexible and reliable.

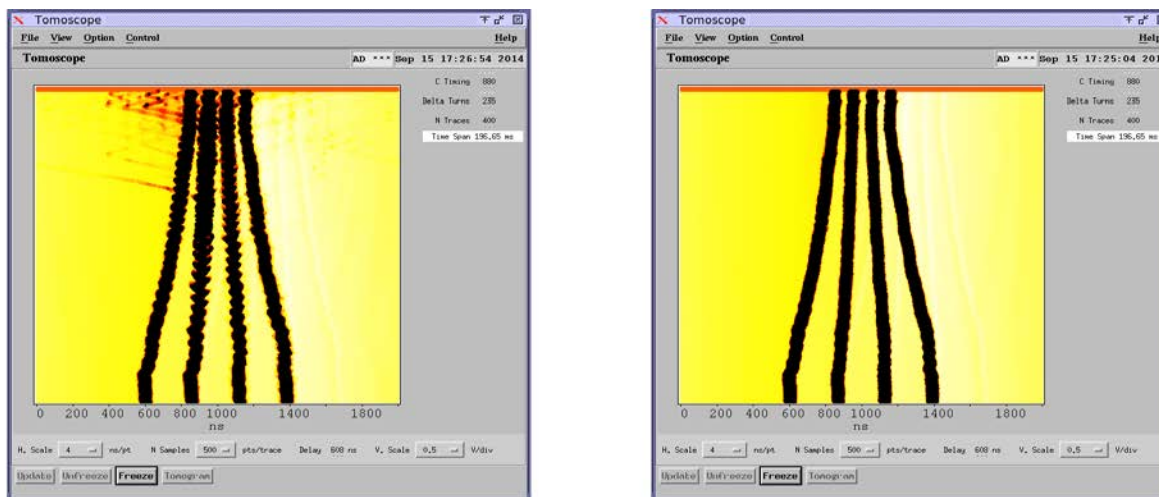

**Figure 22: Batch compression of AD beam in the PS without (left) and with the new 1-turn-delay feedback.**

The C201 power station has been fully upgraded with a new HV measurement system. This should increase the already good stability of the amplifiers by making them even less sensitive to transients that have destroyed the protection system from time to time before LS1. The new configuration will be tested until EYETS, and it will be implemented if it proves to be reliable.

## SPS

The 2014 start-up of the SPS started with the commissioning of the RF low level and the TWC 200 MHz cavity loops. The large-scale renovation of control systems for the SPS RF was deployed operationally. The old controllers based on G64 and the MIL1553 bus have been removed and the new PLC-based systems for the 200 MHz and 800 MHz transmitters and cavity control were installed and are operational. The controls of the Low-Level RF has also seen some renovation with some ROCS function generators being replaced by the new RFFG VME module, and the new VME-based frequency program deployed. Integration of these new systems into the LSA applications layer has required an extensive software development effort both in FESA classes and LSA makerules for settings management. The eradication of G64 crates required construction of new VME RF hardware for pick-up control and alarm crates. Proton beams for fixed target physics and the LHC were re-commissioned for operation and machine developments, including notably the novel “doublet beam” for more efficient scrubbing in the LHC. For the AWAKE Study, the main part of the layout of the synchronization between AWAKE and the SPS was defined in 2014. All SPS RF pick-ups and their low level infrastructure were revised and upgraded; the new SPS Beam Quality Monitor was commissioned successfully.

All SPS 200 MHz cavities and amplifiers restarted smoothly and were quickly fully operational at their nominal performance after a few thousand components had been replaced or modified, tested and put into service during LS1.

The high-power RF system for the TWC800 were fully upgraded to an IOT-based system (IOT=Inductive Output Tube – a tetrode with a klystron-like output cavity), which became fully operational in 2014. Four transmitters are combined to reliably provide 160 kW per cavity. Two cavities can be powered, resulting in eight IOT systems in total. Figure 23 shows the implementation of the new IOT system in BB3.



**Figure 23: The new, IOT based 800 MHz power plant for SPS in BB3**

### **PSB, PS, SPS LS1 work for controls**

Within the ACCOR project, the control systems of the PSB, PS and SPS were renovated. This constituted a major re-commissioning effort in 2014 with many of the systems moved to new controls and software that needed to be debugged. In the SPS, these changes also included the replacement of the function generators by a new VME card developed within the RF group. All systems were available on time with the essential functionality needed for beam commissioning in 2014. Work also included the continued upgrades of the transverse feedback equipment in the PSB, PS and AD.

### **Argon Beam preparations**

The LEIR accelerator was delivering Argon ions at the end of 2014 in preparation of a special Physics run in 2015 for fixed target ion experiment in the SPS. LLRF had to be set up dedicated to this type of beam in the injector chain LEIR-PS-SPS. A new frequency program using the B-train distribution over “White-Rabbit” was developed and tested for this purpose (cf. figure 24) and will replace in the future the analogue B-train distribution system.

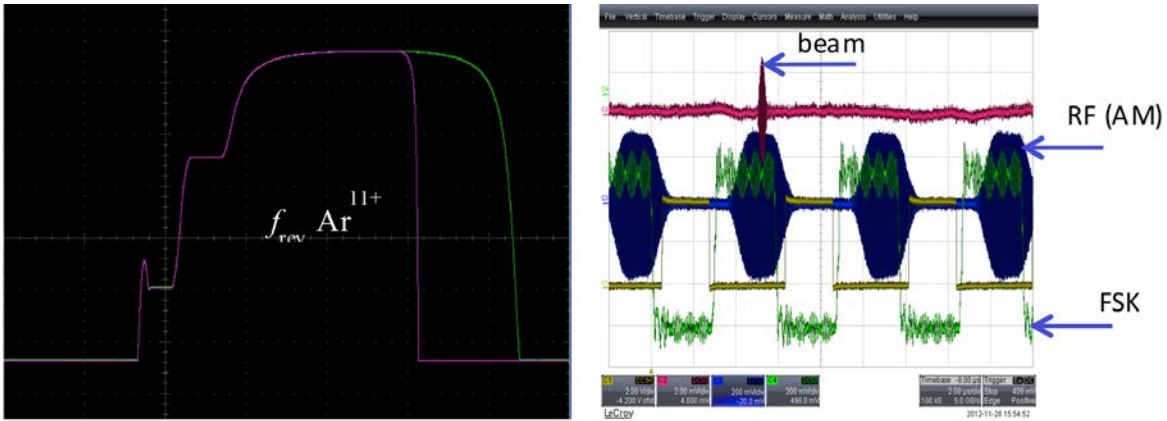

**Figure 24:** Frequency program in the PS for Ar acceleration driven by new B-train distribution (left), AM and FM at  $4 \times f_{rev}$  in the SPS for the acceleration of Ar ions.

## LHC Injector Upgrade

### BE-ABP Group

The LHC Injectors Upgrade (LIU) project aims at preparing the whole LHC injector chain to meet the needs for future LHC high luminosity runs. In 2014, the accelerators of the LHC injection chain resumed operation after the Long Shutdown 1 (LS1) and the machine studies necessary to steer their upgrade could be again carried out. Besides, simulation activities continued in the framework of the LIU project, aiming at refining the simulation tools and benchmarking them against the available machine data to provide the necessary guidance for the needed upgrades.

Throughout 2014, the ABP group has provided instrumental contributions to the progress of the LIU project in management activities, Machine Development coordination and technical support in terms of both simulation and machine studies. The project is proceeding at the planned speed, still aiming at the definition of the upgrades by end 2015 and their full implementation during LS2.

### PS Booster Upgrade

Detailed simulations of the injection into the PS-Booster (PSB) from Linac4 were performed and provided the expected new brightness curve of the PSB after the connection to Linac4. These simulations included space charge as well as the future  $H^-$  injection, and proved that LHC beams with double brightness with respect to what is achievable today can indeed be produced. Relaxing the requirement on the longitudinal emittance and optimizing the working point at injection, even slightly larger brightness values could be in reach.

### PS Upgrade

Intensive machine development activities have also taken place at the PS after its restart in June 2014. Since one of the main bottlenecks to produce brighter beams in the future is the space charge at the PS injection, this effect was widely studied at the injection of the PS to determine how it limits the achievable beam brightness, while configurations to mitigate it, beside the upgrade of the injection energy to 2 GeV, are also under scrutiny. In particular, machine studies

done by changing the integer part of the tune from 6 to 7 revealed that the observed 6.25 resonance line is indeed a structure resonance excited by space charge.

## SPS Upgrade

Two extended periods during the 2014 SPS run were devoted to the so-called “beam induced scrubbing”, i.e. running the machine with beams such as to produce enough electron cloud in the vacuum chamber to lower the Secondary Emission Yield (SEY) of the chamber walls and eventually permit stable operation with LHC beams. A trick used during these periods to speed up the scrubbing process was running the SPS with a special beam that produces more electron cloud than the standard LHC beam, the so called “doublet” beam. The use of this special beam is especially relevant not only for future LIU plans, but also because there is a plan to apply it to reach nominal LHC operation with 25 ns beams in 2015. The first scrubbing period, which lasted one full week, could successfully clean the inner surfaces of the SPS vacuum chamber to the point of recovering the 2012 performance in terms of LHC beam production. After only five days of scrubbing, the LHC 25 ns beam could be accelerated to 450 GeV with the nominal bunch currents and transverse emittances well within specifications. The second period, which lasted only two and a half days, was devoted to increasing the beam intensity in the SPS to values close to the LIU target at injection energy as well as test the acceleration of doublet beams and characterize other LHC beam variants. The recrudescence of the electron cloud and the consequent beam instability in conditions of high beam current indicated that preparing the SPS to produce the future beams might need to rely on active measures of electron cloud suppression, like amorphous carbon coating of the inner wall of the beam chambers along a certain fraction of the machine circumference. In fact, this coating was already applied to 16 magnets during LS1 and the benefit in terms of electron cloud suppression was directly measured over the scrubbing runs. Additional scrubbing studies will take place in 2015 and, only after gathering all the necessary information, a decision about scrubbing or coating will be finally made for the SPS. Electron cloud was not the only focus of the LIU-SPS machine studies in 2014. Impedance studies also took place in both the transverse and longitudinal planes. The vacuum flanges and transition pieces (about 550 all around the ring) were identified as major longitudinal impedance sources of the SPS, which contribute significantly to make the beam unstable above a certain intensity threshold. Consequently, it is now being studied how to optimize and coordinate the efforts to conduct the needed a-C coating and the impedance reduction campaign during LS2.

## Ions

On the heavy ion front, combined machine and simulation studies were conducted with Ar ions for Linac3 and LEIR in order to investigate on source and Low Energy Beam Transport (LEBT) line improvements to increase transmission as well as on LEIR optics model verification.

## BE-BI Group

The LINAC4 Half Sector Test was launched in 2014 with specifications for BI systems becoming clearer. Much work was therefore devoted to understanding these requirements, ensuring that adequate infrastructure was available and adapting the planning for delivery of components, some of which are now needed earlier than foreseen. This test will be important for several BI systems, allowing their performance to be tested in advance of the final LINAC4 to PSB connection.

A Beam-Gas Ionisation Profile Monitor has been requested for the PS machine to provide beam size measurements during the cycle. Design decisions were taken for this system concerning how best to distribute electronics between the tunnel (with high radiation levels) and auxiliary

buildings, to maintain signal integrity and provide best performance. At the moment developments related to silicon pixel detectors (TimePix3), used by several experiments, appear best suited to this application. An overview of the layout based on such a system can be seen in Figure 25.

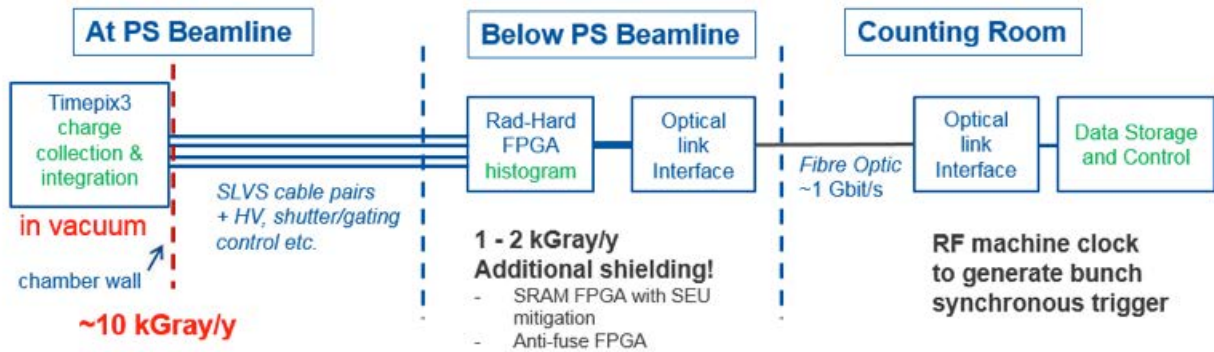

Figure 25: Layout overview for PS BGI electronics

The electronics for the Head-tail monitoring in the SPS was upgraded with a new acquisition system put in place. The first tests with beam showed very good performance, and the system has since been used extensively for intra-bunch oscillation studies during scrubbing-runs and MDs related to understanding instabilities. The full integration into the control system, and the provision for automatically triggered acquisitions is expected for 2015.

LS1 also saw the renovation of the synchrotron light monitor (BSRT) in the SPS, to provide beam size measurement at high energy. Following upgrades to the optical line and detectors, the electronics was installed and the first images were acquired. The results are promising and the final electronics and software implementation is expected to take place in 2015.

As part of a general request to provide beam instrumentation with bunch-by-bunch (40MHz) resolution, several developments were started for the Diamond BLMs in the SPS with two detectors installed in the extraction regions, LSS4 and LSS6. The acquisition is currently based on oscilloscopes and was successfully commissioned. A suitable long-term acquisition solution based on commercial electronics is being investigated to provide additional functionality such as histograms with bunch-losses as a function of time.

Preparation for the installation of a prototype for a new design of wire scanner was also started in 2014. Sector 517 was equipped with a new vacuum tank, pumps and services during LS1. The prototype instrument itself was manufactured and is foreseen for installation in early 2015.

## BE-RF Group

### PSB

As an additional step in the PSB RF renovation studies, the Finemet® based wideband prototype acceleration system was completed during LS1 (figure 26). The ten available cells, all equipped with a second-generation solid-state amplifier, can provide 7 kV accelerating voltage. In combination with the new, dedicated low-level digital electronics, beam test were conducted. The beam induced voltage cancellation process proved very effective, with voltage reduction above a factor 10. When providing 7 kV at  $h = 1$ , the system was able to capture  $695 \cdot 10^{10}$  protons, of which  $650 \cdot 10^{10}$  were accelerated and extracted. Excellent performances were also



shown operating the system on  $h = 2$  ( $790 \cdot 10^{10}$ ) and as multi-harmonic system ( $h = 1$  and  $h = 2$  simultaneously,  $800 \cdot 10^{10}$ ).

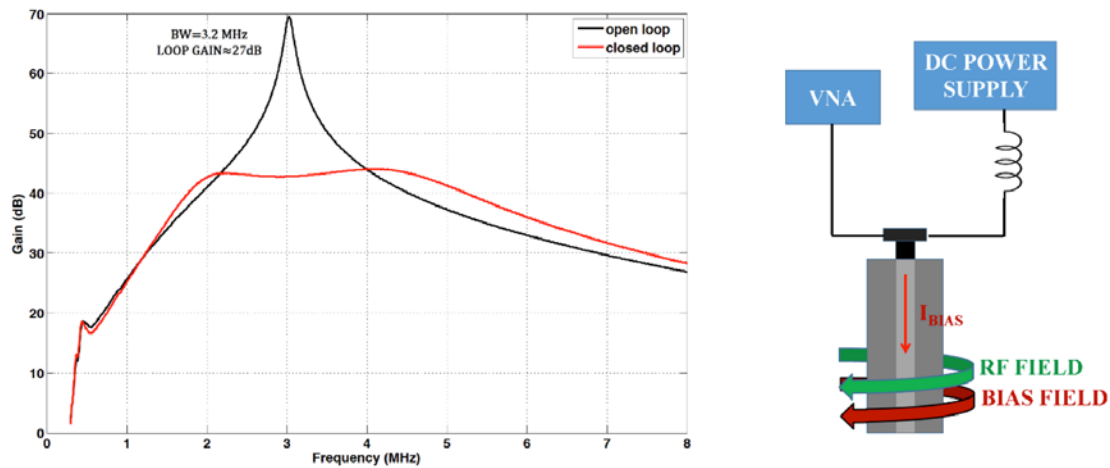

**Figure 26: Ten-cell prototype Finemet® cavity system installed in PSB ring 4.**

## PS

The PS main RF system, the 10 MHz system, is being upgraded in view of the needs of the larger intensities required for HL-LHC, which requires a reduction of the 10 MHz cavities' equivalent impedance. This impedance reduction can be obtained by increasing the feedback loop gain of the RF amplifier chain driving the accelerating cavities. The proposed solution considers the modification of the RF power tetrode working point, thus increasing the amplifier forward gain, and includes some interventions on fundamental amplifier components in order to keep the RF phase under control, so to assure a stable operation of the whole system. Preliminary measurements and PSPICE simulations indicate that a feedback gain of 27 dB at 3 MHz can be obtained at 3 MHz with sufficient stability margin, as indicated in figure 27 left.

The 10 MHz grid resonator is made of ferrites and tuned in the same frequency range as the cavity. The planned modification of the system required measurements of several ferrite samples which in turn triggered the development of a novel measurement technique. To this end, ferromagnetic material characteristics have been studied at different working points and new measurements and evaluation methods have been developed.



**Figure 27: Left: Measured open and closed loop response of a 10 MHz system after the upgrade, indicating an impedance reduction by a factor 22 (27 dB). Right: Test set-up to test ferrites under different bias conditions.**

The developed measurement technique allows to measure ferrite complex permeability and its dependence on external bias field. In the measurement set-up, ferrite rings under test are housed by a coaxial line with one shorted end (figure 27 right). The magnetic field is maximum on the shorted end, thus making this test-set suitable for the measurement of the ring magnetic properties. The desired magnetic quantities are computed from the input impedance of the device under test, through calculations based on the shorted transmission line theory properties.

## SPS

The longitudinal impedance model of the SPS was significantly improved using electromagnetic simulations and lab measurements. Systematic studies of intensity limitations for the LIU beams during acceleration ramp were performed and new ideas to reach the HL-LHC intensity target were explored, as e.g. bunch rotation in the SPS at flat top and longer ramps to ease beam loading limitations. MDs helped to understand SPS stability limits; near the end of the year several 25-ns-beams were studied in detail in preparation of LHC run 2 (high intensity 25 ns, doublets, 8b+4e, BCMS).

Studies of momentum slip stacking of ion bunches led to the change in the LIU baseline.

A prototype of the new digital LLRF has been installed on the 800 MHz cavity 1 and was commissioned during 3 MDs in autumn 2014: Acceleration of a 72-bunch batch with  $10^{11}$  p/bunch. The reported results were excellent and encouraging:  $< 1^\circ$  peak-to-peak uncompensated transient beam loading along the batch!

The SPS LIU damper upgrade made significant progress in 2014 with the move to new, dedicated digital hardware. Supervision for the cabling was provided and all equipment in surface racks was entirely changed and re-cabled. At the heart of the system are new VME crates following the LHC LLRF standards, for which a number of dedicated modules were produced. The digital VME board was developed to be compatible with LHC needs. Four damper loops were commissioned in both planes with dedicated signal treatment; a fifth crate serves as a development system.

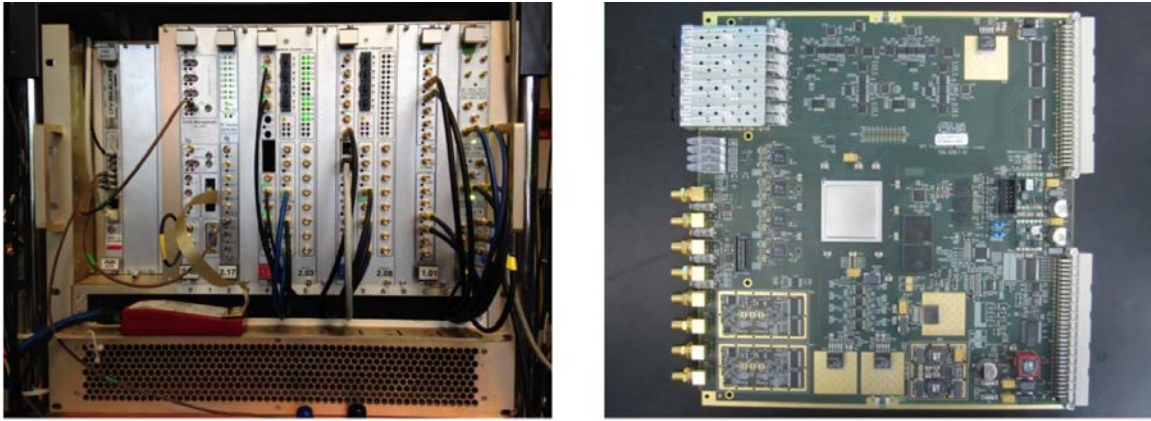

**Figure 28 : New SPS transverse damper hardware: VME crate (left), digital LLRF VME board (right).**

Collaboration with LARP continued for the development of a wideband transverse feedback system in the SPS. A major milestone was reached in 2014 with the installation of dedicated new stripline kickers in LSS3 for this system. As in the LHC (see above), the SPS dampers were upgraded with new air and water cooling system to extend the tetrode lifetime.

The 200 MHz amplifier upgrade project has equally made good progress through 2014. A contract for the driver amplifiers was awarded and very first prototypes were delivered and found compliant. Tendering for the final was prepared and sent out to 17 qualified companies, keeping open the choice of technology: SSPA, IOTs, Tetrodes and Diacrodes.

The new RF BAF3 building construction work was completed – the large amount of snow during the Christmas break made a successful and relevant “validation test” for the new building – not a single default could be detected.



**Figure 29: The new BAF3 building in April (left) and in October 2014 (right).**

## AD/ELENA

### BE-ABP Group

Preparations for the construction and installation of the Extra Low ENergy Antiproton ring ELENA, a small 30 m circumference synchrotron aiming at further decelerate antiprotons from the Antiproton Decelerator AD down to 100 keV to improve the capture of the experiments, have continued over the whole year. A Technical Design Report TDR describing the machine to be constructed, which has significantly evolved since the start of the project in 2012 and is well known and understood now, has been published in spring. Based on this TDR, the ELENA project has been presented at a cost and schedule review, where the plans have been found well prepared and sound.

An important step for the project was the completion of an annex building to the AD hall in spring mainly to install kicker generators for the AD, and later the ELENA injection kicker, occupying until the end of the 2014 AD run at the location, where the ELENA ring will be installed. Immediately after the end of the AD run, the relocation of kicker generators started in order to allow preparations and installations for ELENA from spring 2015 onwards. The first part of the AD extraction has been consolidated taking future needs for ELENA into account and to create space for bending magnets deflecting in the future the beam towards ELENA.

Almost all contracts for large equipment, such as magnets or the magnetic system for the electron cooler purchased from industry have been placed. A very important finding for the project was that “thinning”, i.e. alternating laminations made of magnetic steel with thicker laminations of a non-magnetic material, does not improve the magnetic field quality at very low field levels. This initially empirical observation by the team working on ELENA magnets is well understood now; as a consequence, all ELENA magnets will have conventional yokes to obtain a better field quality. Preparations for manufacture of smaller equipment have advanced well as well.

The aim for the near future is to install the ELENA ring and a small part of the transfer lines until spring 2016 followed by commissioning of the ELENA ring until the end of the run 2016. Then new electrostatic transfer lines from ELENA to the existing experiments can be installed and commissioned in 2017 for a short first physics run with 100 keV antiprotons at the end of the same year.

### BE-BI Group

A prototype BPM for the ELENA orbit measurement system was manufactured and tested in 2014. It consists of two sets of electrodes, one set per measurement plane, mounted on both ends of a common vacuum chamber. The vacuum chambers will exist in two different lengths to fit inside either a quadrupole magnet or a corrector magnet. Photos of the detector can be seen in Figure 30. The measured linearity is excellent, and the sensitivity confirmed to correspond to what is expected.

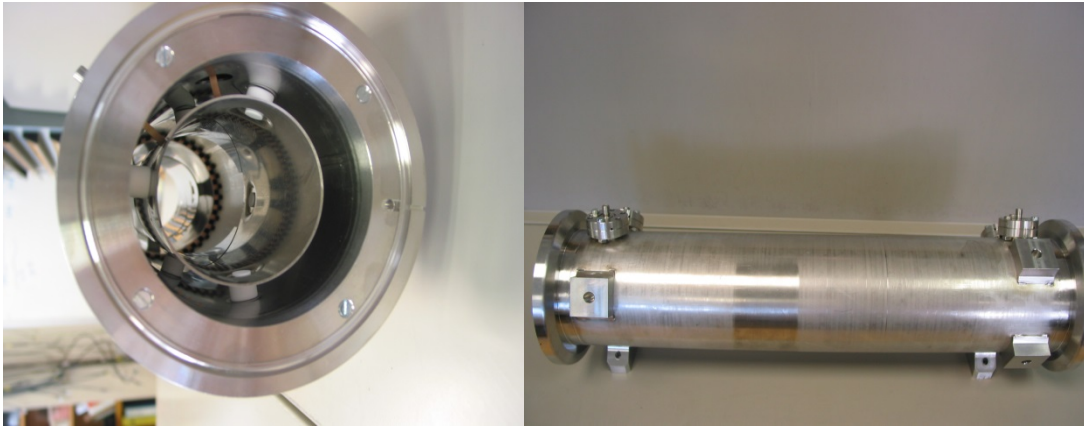

**Figure 30: Prototype BPM for ELENA**

There was also good progress with the mechanical design of the ELENA tune measurement pick-up (Figure 31). The ELENA tune kicker will use the same design.

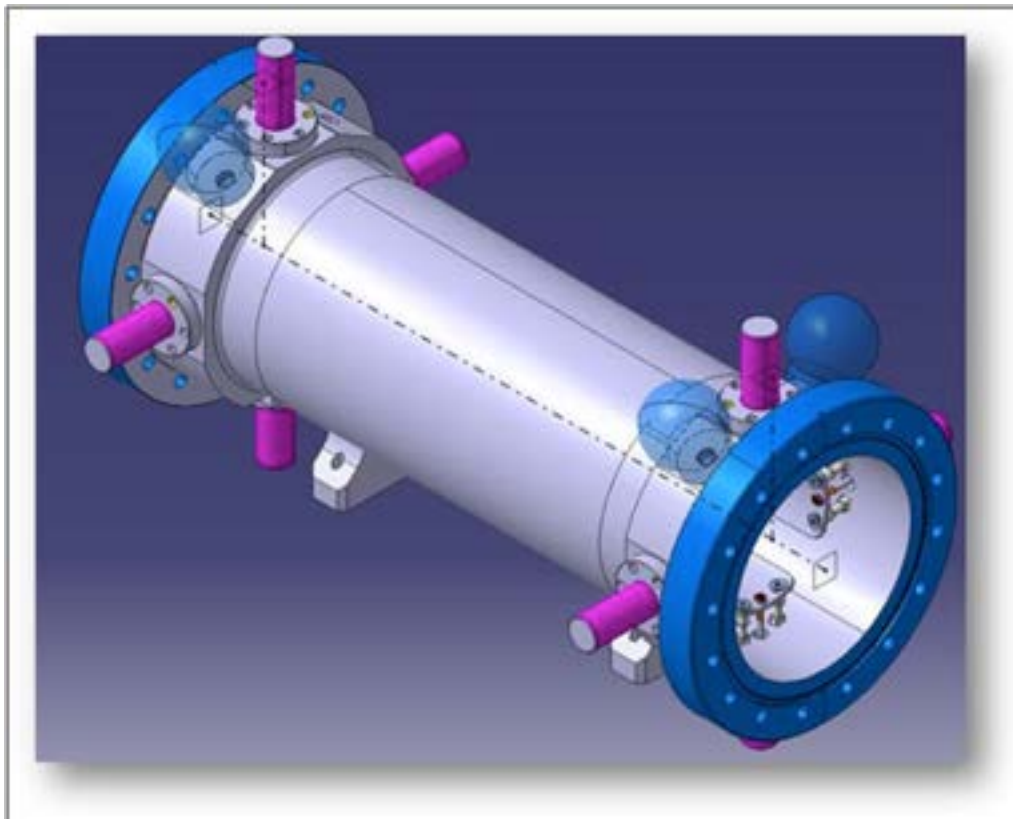

**Figure 31: 3D drawing of the ELENA tune stripline kicker and pick-up**

## **BE-CO Group**

### **The InCA/LSA project**

InCA has been deployed on the AD machine replacing the existing system. An important work has been carried to integrate the InCA with the new AD central timing, AD Cycle Editor and the orbit steering application YASP.

### **General Machine Timing**

The main controls development for the AD was a new central General Machine Timing system, implementing in particular a new scheme for injection from the PS. The system was developed and successfully integrated into the OP set of applications and tools.

## **BE-OP Group**

All teams involved in AD consolidation, upgrades and renovation were kept very busy until the end of July when the start-up took place after more than 18 months of shut-down.

The following systems were then ready to be switched on and tested for the first time after extensive renovation or renewal:

- Target area & associated equipment
- Control system with software upgrades.
- Timing system & cycle generation software.
- Magnets with several units rebuilt or replaced.
- Vacuum system.
- Stochastic cooling system.
- RF-systems.
- Access points & safety interlocks.

To be added to this, an additional transfer line had been designed, manufactured and installed in the AD experimental area. This line will transfer low-energy pbars to the new BASE experiment bringing the number of active experiments at AD up to 6. The goal of the BASE collaboration is to perform high-precision measurements of the magnetic momentum of a single trapped antiproton.

The first major step in preparing for installation of the ELENA ring was also realised; the AD ejection line was modified to accommodate for the future installation of a branch-off towards ELENA.

The start-up with beam was delayed due to a late discovery of a fault in the strip-line that transfers the 400kA/6kV pulse to the Magnetic Horn (a device in the target area that focusses the antiprotons emerging from the production target). Repairs included manufacturing of certain spare parts and also setting-up of a special test-bench in B195 where complete tests were made to the power supply, stripline, chariot and horn before final installation in the target area.

On the 5/8 the production target was finally hit with the first proton beams of the year and production/injection/circulation of antiprotons was quickly established. This was followed by a complete set-up of the deceleration cycle and all the associated processes. Progress was somewhat slower than expected, mainly due to complications related to the many modifications

done during LS1. Nevertheless, 100 MeV/c antiprotons could finally be delivered to the users on the 16/9.

Commissioning of the transfer-line to the new BASE experiment was very successful and fast, beam was delivered from day 1 and the first signs of trapped antiprotons were seen soon after.

A total of some 2100 physics hours had been realised by the end of the year and despite a somewhat slow start-up, the overall beam availability to the users was in the order of 85%.

## **BE-RF Group**

Work in the AD complex included re-location of RF equipment to prepare for the future ELENA ring. RF responsibility for ELENA includes the development and follow-up of production of dedicated longitudinal pick-ups and the production and customization of the LLRF system based on the technology for the PSB, both for the RF longitudinal loops and for beam observation. Hardware was produced and the customization planned. Work on the pick-up was advancing with drawings being produced, parts manufactured and material procured.

For the stochastic cooling system, the upgraded controls of the “platform Fritz” was commissioned and has permitted to optimize the set-up for the stochastic cooling system. The system supervision from the CCC has been much improved by this consolidation. Maintenance work included extensive repair for the 48 stochastic cooling amplifiers. Contacts have been established with GSI for the development of an optical notch filter which can replace the ageing notch filter using cables and improve the stability for the operation of the system.

## **LINAC4**

### **BE-ABP Group**

In March, the re-commissioning of the Linac4 at 3 MeV, including the Radio Frequency Quadrupole (RFQ) and the Medium Energy Transport line (MEBT) was completed after the machine was moved from the test stand (bdg. 152) to the tunnel (bdg. 400). The machine performances already achieved at the test stand were fully recovered in the tunnel. The beam measurements, the characterization of the RFQ and of the MEBT components were found to be in very good agreement with the expectation from simulations.

Between April and July the first Drift Tube Linac tank and the temporary diagnostic bench were installed. The first beam was measured out of the DTL in August, accelerated to the nominal energy of 12 MeV. After a beam stop of 1 month, to allow for extra RF conditioning of the DTL structure and for the Linac14 conference visit, the 12 MeV commissioning stage resumed from October to the Christmas break. The transverse (permanent magnet quadrupole focusing channel in the DTL) and longitudinal measured characteristics of the DTL confirmed the very good performances of the DTL structure. During the 12 MeV commissioning stage, the Time Of Flight and the indirect emittance reconstruction techniques in both transverse and longitudinal planes, which will be the sole measurement methods for next commissioning stages, were cross-checked and validated.

## BE-BI Group

At the beginning of the year, the LINAC4 source, the LEBT, the RFQ and the MEBT (chopper line) as well as the 3 MeV measurement lines were moved from the 3 MeV test stand into the LINAC4 tunnel. All diagnostic devices were then re-commissioned to ensure their performance before handing them over to the LINAC4 commissioning team, who successfully used them to characterize the beam at 3 MeV.

A major achievement was the vertical emittance measurement made with a novel laser wire scanner. The laser strips a very small portion of the  $H^-$  beam, transforming the  $H^-$  ion into neutral  $H^0$ . While the major part of the beam is bent into the spectrometer line, the  $H^0$  beamlet continues straight on where it is measured by a diamond detector. Scanning the laser through the beam using a mirror system and measuring the angular distribution of the resulting  $H^0$  beamlets allows reconstructing the phase-space in a very similar fashion to the slit/grid method. A direct comparison of the two methods as can be seen in Figure 32. The advantage of the laser system over the slit/grid system is its non-invasiveness, allowing it to be used for high intensity beams.

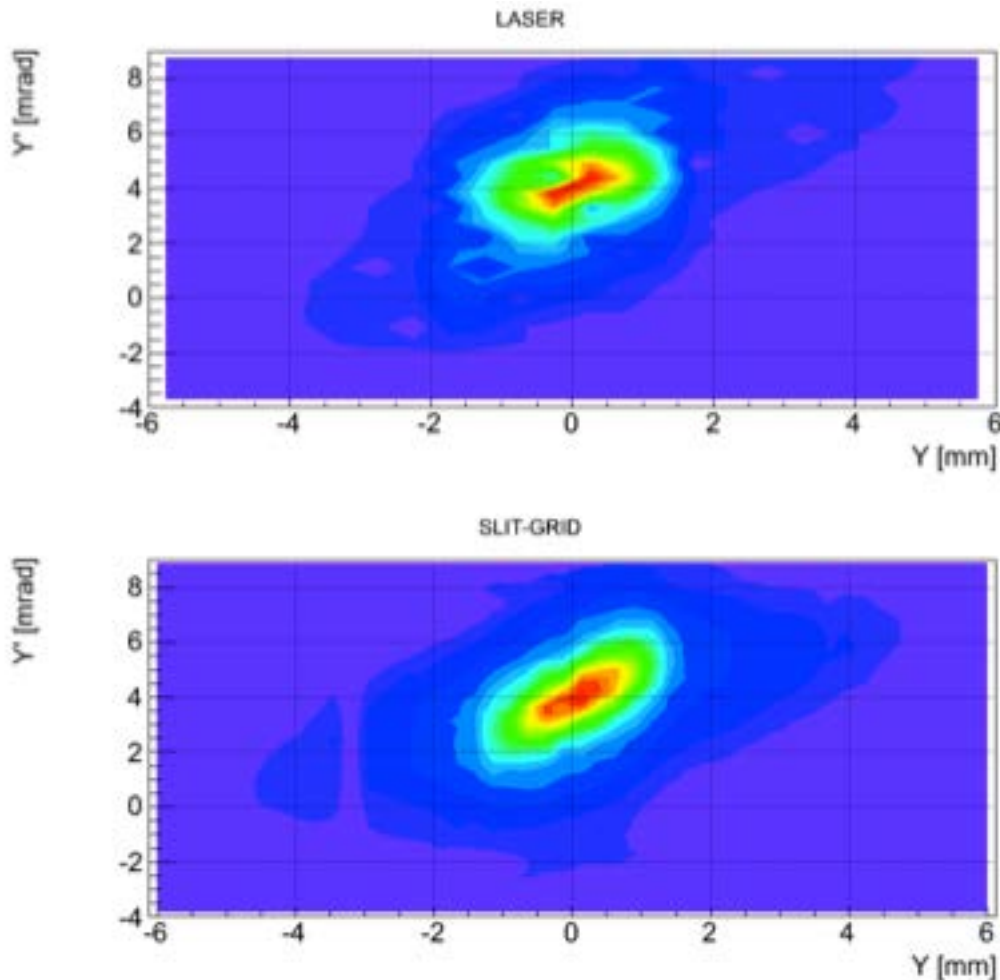

Figure 32: An example of the vertical phase space as reconstructed by the laser wire and the slit/grid emittance meters

After the 3 MeV commissioning, the first Drift Tube Linac (DTL) tank (accelerating the beam from 3 to 12 MeV) was installed in the machine and the measurement line with all its instrumentation displaced to the new position after this first DTL tank. The future inter-tank



section (between DTL tank 1 and 2) was equipped with a new Beam Position Monitor (BPM), which had to be installed inside a steerer magnet due to very limited space available.

As for the 3 MeV case, the Beam Current Transformer was the first instrument to measure the 12 MeV beam, allowing transmission measurements through the DTL tank to be made.

There was good progress in commissioning the BPM system, with the Time-of-Flight (ToF) measurements used for the first time to determine the beam energy. This was performed by varying the RF amplitude in the DTL tank with the RF phase scanned for each of these RF amplitudes. This results in slight variations of the beam energy where the shape of the phase-energy curve has a characteristic form. The Time-of-Flight measurements were compared to simulations, from which the optimal RF settings could then be determined. Figure 33 shows the comparison of the Time-of-Flight as measured by the BPMs with simulation results for various RF amplitudes.

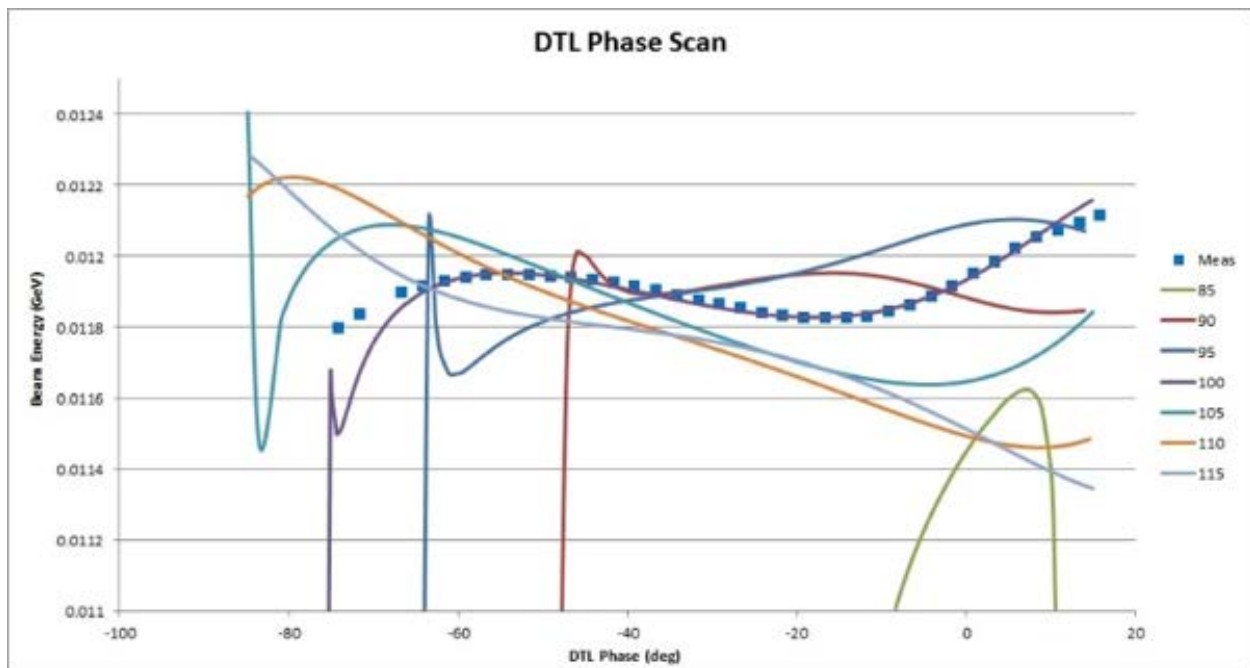

Figure 33: Energy vs RF phase for different RF amplitudes in DTL tank 1 compared with Time-of-Flight measurement using 2 BPMs.

## BE-CO Group

Activity in Linac 4 was focused around the development, deployment and commissioning of the controls for the diagnostics line. Linac 4 also saw the deployment of a new generation of pulse repeaters which will be the basis for upgrading legacy repeaters in other accelerators.

## BE-RF Group

### Linac4 RF structures

After the successful commissioning of the Linac4 front-end (source, RFQ, MEBT) in the Linac4 tunnel towards the end of 2013, the installation of RF structures continued with the first DTL tank in June 2014. In parallel also the installation of the CCDTL started, and by July four out of seven modules were placed in the tunnel. The conditioning of DTL1 went smoothly with first beam injected in August. Furthermore all 53 movable tuners were received, almost all support jacks were installed in the tunnel and the first Linac4 couplers and in-house produced windows of the series production were high-power tested during the conditioning of the Linac4 RF structures. In addition, 4 CCDTL modules were conditioned by the end of the year and the first externally produced PIMS cavity was assembled and tuned at CERN, validating the mechanical tolerances and the production procedures.

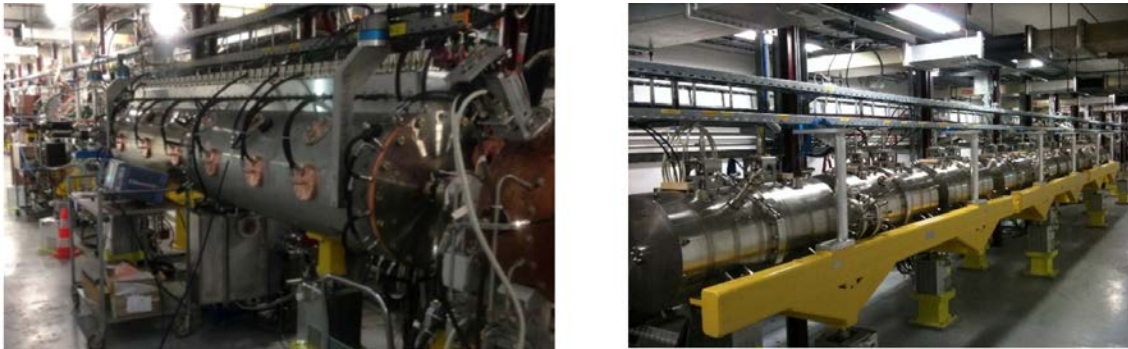

Figure 34: DTL1 (left) and 2 CCDTL modules (right) in the Linac4 tunnel

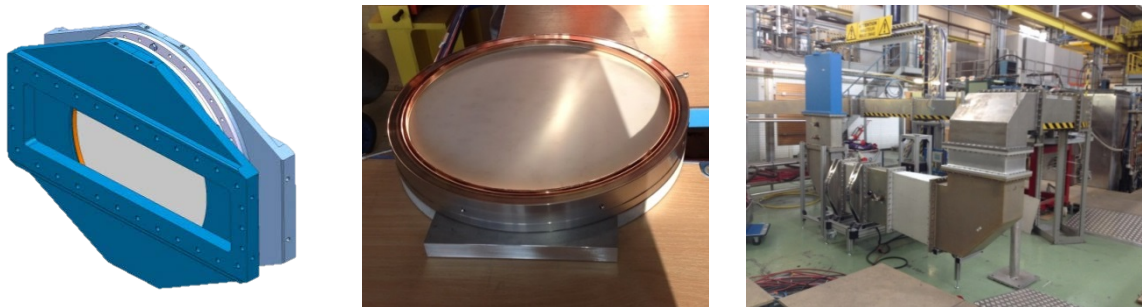

Figure 35: The Linac4 window design (left) and realization (centre). The 3 MeV test bed with two windows under RF processing and power testing (right).

Linac4 was then commissioned with beam to 12 MeV: RFQ, bunchers, chopper and DTL1. A suite of "expert" inspector tools has been developed for conditioning; Matlab® tools were developed for setting-up the LLRF.

In total, about 80% of the Linac4 high-power system was installed, comprising the high power equipment, the power distribution system, cabling, water cooling distribution as well as the interfaces with other systems. Six HPRF units were successfully fully commissioned. The preparation of the remaining equipment took place in the test B112 test place. All the installed systems were successfully operated during beam tests. FESA software has been developed for the LLRF Cavity Controller used for all structures.

Acceptance tests of new equipment, retuning of the LEP klystrons and development of a wave guide phase tuner were the major activities.



Figure 36: View in the Linac4 equipment room in 2014

## **COLLIMATION PROJECT:**

### **BE-ABP Group**

In 2014, the activities of the collimation project team have been focused on the preparation of the LHC Run II system. The main achievements in LS1 were the installation of 18 new collimators with embedded BPMs in the jaws, for fast alignment and orbit monitoring, and the upgrade of the physics debris collimation layouts in the high luminosity points IR1/5, where 2 physics debris collimators were added per beam. Other collimators were replaced and/or consolidated in the tunnel for a total of 32 collimators installed in the ring. The team also worked on the preparation of the remote commissioning of the system. By the end of 2014 the whole system was up and running. The definition of collimator settings for 2015 and  $\beta^*$  reach from collimation was also completed, allowing to define baseline and alternative scenarios for the start-up, as presented at the Evian2014 and Chamonix2014 workshops.

The new BPM collimators were produced in industry (tertiary collimators in all IRs) and in house (secondary collimators in the dump region). In order to prepare the beam commissioning

of this new design, a test stand was setup on surface and beam tests were carried in the SPS to commissioning the new software that will be used to control the BPM functionality, achieving a record time of less than 20 s to align a collimator to the circulating beam. The control software is developed as a joint collaboration between ABP and BI.

The collimation project teams also work on the system upgrade for the HL-LHC upgrade. In 2014 a first solid baseline for the collimation upgrade was established, covering upgrades for the cleaning insertions as well as for the IR collimation. The design of low impedance collimators for the betatron cleaning and for higher robustness was advanced to the extent that the production of a prototype jaw has been launched (for tests at HiRadMat). Alternative scenarios to the baseline are also studied, like the option to use hollow electron beams to enhance the collimation performance, and crystal collimation. In 2014, the LHC IR7 was equipped with a setup for crystal collimation studies for Beam 1, for beam tests at low intensity in 2015.

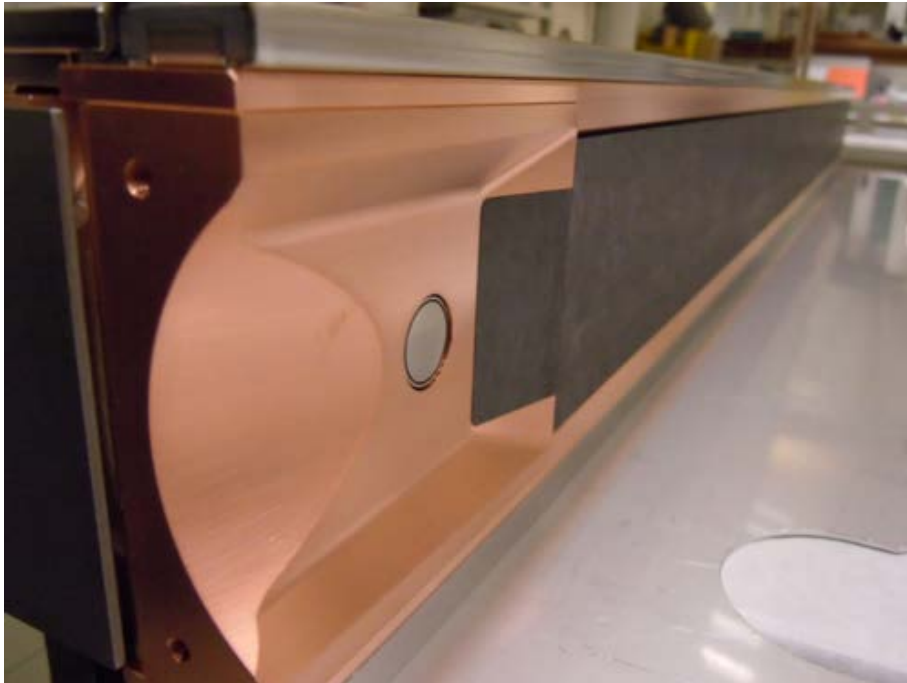

**Figure 37: Photograph of a reinforced Carbon Fibre Composite (CFC) collimator jaw with integrated beam position monitor.**

## **BE-BI Group**

16 TCTs and 2 TCSPs collimators with embedded button pick-ups were installed in LHC during LS1. These embedded BPMs are read-out using new Diode ORbit and Oscillation (DOROS) electronics. This electronics was finalised and successfully validated with real beam tests through MDs performed in the SPS. A resolution better than 1  $\mu\text{m}$  was demonstrated.

## **REX/ISOLDE/HIE-ISOLDE:**

### **BE-ABP Group**

The ABP group is responsible for the low-energy part of the REX-ISOLDE post accelerator, which with the installation of the superconducting linac extension is soon to become HIE-ISOLDE. Because of the installation work of the linac, no beams were delivered for physics, however, the time was used for performing machine development. During a shorter test run both stable and radioactive beams from ISOLDE were taken into the low-energy system of REX. Exceptionally long holding times in REXTRAP (up to 2 s) were tried for a radioactive beam as a preparatory test for the TSR@ISOLDE initiative. Owing to an improved stability of critical power supplies, in combination with a recently implemented cooling technique in REXTRAP, an improved transmission efficiency of the complete system for very high beam intensities could be demonstrated. This is promising for future beam-intensity upgrades. The performance and long-term stability of an electron cathode using a different mounting structure from an alternative supplier was also tested, although it was not found to be more reliable in its present con The study of an upgraded charge breeder based on the HEC2 electron gun continued in collaboration with BNL. Ions were extracted from the setup and mass spectra were recorded. A modified electron gun, with adjustable position of the cathode-Wehnelt assembly with respect to the anode was tested, but only a marginal increase in the electron current, limited by loss current on the anode, was obtained. Refined electron beam simulations carried out at CERN have ruled out electron reflection from the collector region as a cause for the excessive loss current, and instead suggest the reason being side-emitted electrons from the cathode. Changes in the gun design and electron transport system are being introduced to address the issue. A conceptual design report of an upgraded charge breeder for HIE-ISOLDE was also prepared.

The work to expand the available ion-beam diagnostics tools has continued, and all mechanical pieces for both a pepper-pot emittance meter and a Time-of-Flight (ToF) mass spectrometer were finished. An attempt to measure the ion-beam energy-spread out of the EBIS was made using an already existing energy-spread analyser, but due to the beam optics restriction a non-sufficient resolution was obtained, and this has triggered the design of a new beam-focus-independent unit.

At the TwinEBIS test bench the first electron beam could be launched early in the summer. Soon thereafter a record electron current of >550 mA was propagated - 10% above the design goal and never previously reached at REXEBIS - and the soundness of the initial electron-beam optics design could thereby be verified. An improved understanding of the limiting electron loss current and the sensitivity to a misaligned magnetic with respect to the electron beam optics was gained. Conclusions about work functions for different crystal orientations of the cathode could also be drawn. Furthermore, a non-separated ion beam has been extracted and monitored on a ToF detector. By making use of this, and an extension of the Labview programme now also including a real-time system, the ion-pulse length could be modulated. In the autumn the setup was moved to a dedicated, larger test area with possibility for a later addition of a full-fledged extraction line.

## BE-BI Group

### HIE ISOLDE

During 2014 all 6 HIE-ISOLDE ‘short’ diagnostic boxes (tanks and detectors), designed to fit into the cryostat inter-tank region, were delivered to CERN. After having successfully passed a series of acceptance tests, each device installed in all the diagnostic tanks was precisely aligned with respect to the theoretical beam axis. An example of such alignment for a slit is shown in Figure 38.

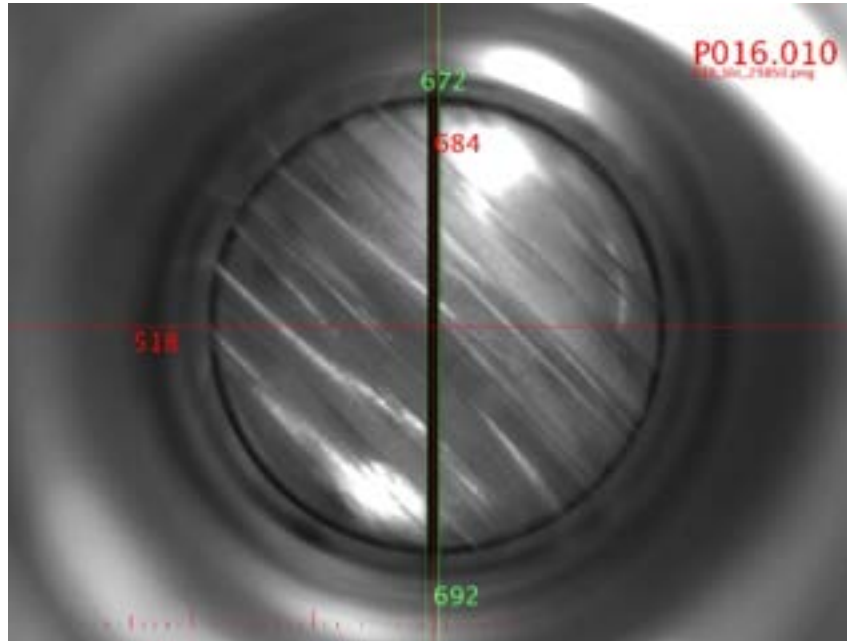

**Figure 38:** A scanning slit inside a short diagnostics box during alignment via a reference target and a CCD camera.

The design of the ‘long’ diagnostic boxes for the experimental lines was completed and production of 9 assemblies launched. The concept of these devices is the same as for the short boxes (see Figure 39), with the difference being a longer Faraday cup detector and consequently longer tanks, something not possible in the inter-tank region due to the limited space. This longer Faraday cup gives less signal degradation due to escaping secondary electrons due to its more efficient high voltage repelling electrode.

**Figure 39:** Conceptual design of the HIE diagnostic boxes.

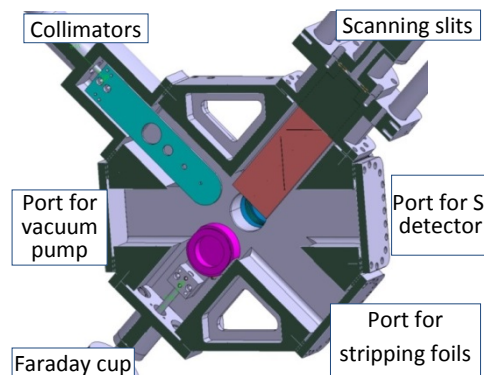

After validating the prototypes produced in 2013, 20 new VME boards designed for controlling and reading-out the diagnostic box instrumentation were produced, tested in the laboratory and installed in the HIE-ISOLDE control chassis. The FPGA firmware for these boards was also developed and tested, including the interlock logic to prevent any collision among instruments in the same tank.

The 2013 version of the low current amplifier for the Faraday Cup detectors was upgraded to a new version (Figure 40) with better signal to noise ratio, while the control and acquisition electronics for energy and time of flight measurements using silicon detectors was selected to be based on fast VME ADC and TDC modules. Low-level software for these diagnostic systems was developed and tested with a radioactive source.

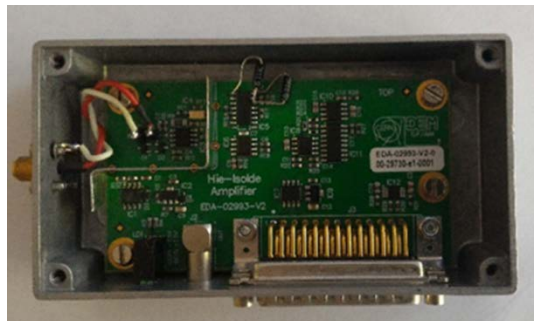

**Figure 40: Latest version of the high sensitivity amplifier for the Faraday Cup detectors of the HIE-ISOLDE diagnostic boxes.**

## **BE-OP Group**

The start-up of the ISOLDE facility was every challenging due to the large amount of modifications and changes done to the machine and the target-zone in particular during LS1. The main interventions in the target-zone impacting the start-up were the installation of the new GPS and HRS robots, the PAD/MAD access system and modifications on shielding and ventilation for the newly added MEDICIS extension.

Some of the work that was supposed to finish by the end of LS1 continued during the cold-check of the facility. This made the restart particularly difficult. Delays were caused by the underestimated amount of work, the radiological nature of the interventions and the impact of co-activities in the controlled areas on operations. With regard to the ISOLDE machine itself the main interventions were the refurbishment of the HRS slits and GPS deflector plates mechanics and controls and the major overhaul of the HRS ISCOOL RFQ where all elements inside were re-aligned and many modified. Some severe technical failures at the start-up like the HRS separator vacuum leak and HRS ISCOOL transmission issues during the re-commissioning of the RFQ made starting up ISOLDE not easier. However, thanks to the early check-out phase, the good support and the hard work of the different support groups during the start-up, the delay on physics was minimalized. The target-zone was closed by the 22<sup>nd</sup> July and protons from PSB taken on the GPS and HRS targets by respectively the 23<sup>rd</sup> and 28<sup>th</sup> July. The 2014 physics run started with a delay of only 2 weeks for GPS and 2-3 weeks for HRS.

## **BE-RF Group**

### **HIE-ISOLDE**

Installation for the infrastructure for the LLRF and high-power systems of HIE-ISOLDE were completed. The production of LLRF boards was launched and design of the firmware and software for the control of the cavities advanced well. System tests were performed on a warm cavity in the lab and the schedule for installation in the machine was adapted to match the assembly of the cryomodule. Final commissioning of the loops has been planned on cold cavities, which will be available only in 2015.

During the course of 2014 the HIE ISOLDE project team was engaged in the series production of SC quarter-wave resonators for the first high beta cryomodule. The copper cavities are manufactured in industry, but all the subsequent steps for the realization of a Nb/Cu cavity are carried out at CERN, in the framework of the HIE-ISOLDE Accelerating Structures Working Group, gathering specialists from BE-RF, EN-MME, and TE-VSC.

Following the R&D phase, a detailed production protocol had been elaborated, specifying the process parameters for all steps, from the copper cavity acceptance and pre-tuning to the surface preparation, the Nb sputtering, the cavity rinsing and dressing, and the RF tests at 4.5 K. The tuning step required some further research to understand all parameters influencing the resonance frequency shift between the copper cavities as built and the final Nb coated resonators in the accelerator environment.

The quality of the industry-produced copper substrates was in several cases not adequate for the Nb coating, which caused some delays. In spite of these problems the first 5 cavities had been successfully processed and tested and were available for the installation in the cryomodule by the end of 2014. The assembly of the first cryomodule at CERN started in September 2014 in the dedicated clean room at SM18, which had just been finished and qualified in August.

The HIE-ISOLDE cryomodule is of the common vacuum type, i.e. the insulation vacuum is equally the beam vacuum. This has some advantages, but requires strict procedures for the assembly to prevent particulate contamination of the RF surfaces. The assembly of the first cryomodule was a joint venture between BE-RF and TE-MSC, who are responsible for the cryostat design and procurement. By the end of the year, the assembly of the first cryomodule was well advanced, and the team was ready for the installation of the active elements (SC cavities and solenoid).

## **SPL**

### **BE-RF Group**

The RF group together with EN-MME, TE-MSC, TE-VSC and TE-EPC continued efforts to develop the technology, infrastructure and procedures needed to achieve high-gradient performance with multi-cell Nb cavities. The objective is to construct, assemble and high-power test a 4-cavity cryomodule (see figure 41) at 704 MHz and to achieve accelerating gradients in the region of 25 MV/m.



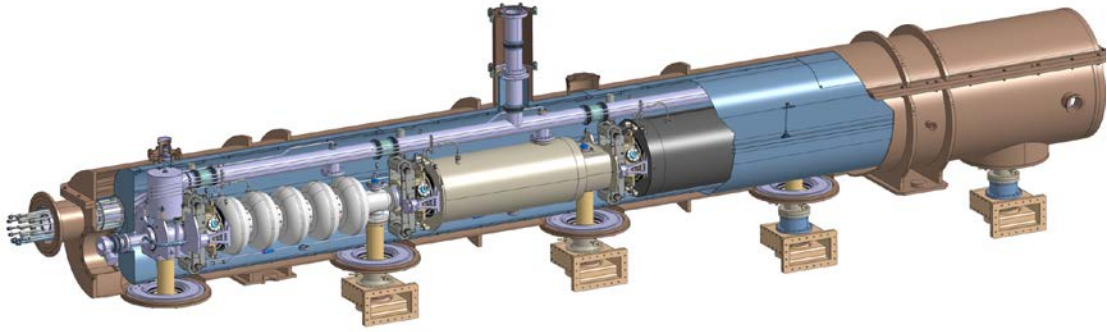

**Figure 41: Four-cavity SPS cryomodule conceptual design for 704 MHz**

In 2014, four 704-MHz, 5-cell Nb cavities, which were received in December 2013, were mechanically qualified. The first cavity underwent chemistry in the new Electro-Polishing facility, and a first cold test was made in July in SM18. The tests were stopped at only 3 MV/m due to heavy field emission. After implementing significant improvements on the high-pressure rinsing system, the mounting procedure and on the magnetic compensation in the vertical cryostat, the cavity was re-tested in December up to a gradient of 9 MV/m. The tests were stopped due to burned connectors and will re-start in 2015. Even though the achieved field levels were still far from the envisaged 25 MV/m, these tests allowed to commission the newly installed infrastructure for cavity assembly, cleaning, and cold tests in SM18 and served to establish and to improve the procedures for cold-testing of high-gradient, multi-cell Nb cavities. In parallel, high-gradient tests were performed at CEA on a EuCARD 704-MHz cavity with identical geometry. Initially gradients were very poor due to excessive amounts of hydrogen in the cavity. After a baking at CERN, the cavity achieved up to 20 MV/m with heavy field emission in the Saclay test stand.

For the establishment of a 704 MHz high-power test stand in SM18, CERN received and qualified a high duty-cycle modulator via the collaboration with ESS. The modulator is on loan and is meant to power the 704 MHz klystron that was received and tested at CERN in late 2014. Furthermore all the waveguides, circulators and splitters were procured, which will be needed to power the four cavities of the 4-cavity cryomodule.

For the construction of cryomodule and cavities, CERN has received the helium tanks for the cavities; the vacuum vessel of the cryomodule has been ordered. Both items were part of the French special contribution to CERN. Fabrication procedures were developed for the construction of multi-cell Nb cavities at CERN and the cavity tuning machine has been tested and qualified.

In May, the “4<sup>th</sup> Open Collaboration Meeting on Superconducting Linacs for High Power Proton Beams” was organized at CERN with support by ESS and attracted 70 participants. In November, the conceptual design report of the low-power and high-power SPL was published [CERN-2014-007].

## **CTF3/CLIC:**

### **BE-ABP Group**

The beam loading experiment in the CTF3 dog-leg beam line was one of the highlights of the year. RF conditioning to a sufficient level was rapidly achieved, and first results were obtained showing that beam loading does not worsen the structure breakdown rate and pointing to a

possible optimisation of the structure design to increase its performance. The Two Beam Module (TBM) has been installed in summer 2014 as planned, in spite of the very aggressive schedule, and successfully commissioned during the autumn run. Several issues with its RF network were identified through beam measurements and successive tests, and have been corrected.

Progress in CTF3 during 2014 included improvements in the bunch train recombination (factor 8), leading to better repeatability and a current stability enhanced from a few percent to a few 10-3. Further progress in availability was obtained by qualifying a new supplier of RF sources for the sub-harmonic bunchers and refurbishing and consolidating the old ones. A realignment campaign was initiated and will be completed in 2015. The drive beam phase feed-forward system was commissioned with limited power, before it will be upgraded to nominal power in two steps. The kick response and the bump closure was verified and a first test has demonstrated a feed-forward gain of the order of 2 and identified the main limitation, uncorrelated phase noise growth between the end of linac and CLEX.

All CLIC diagnostics tests planned were successfully carried out, in particular the performance of the main and drive beam BPMs in CLEX were as expected and the Electro-Optical bunch length monitor run successfully, showing sub-ps resolution after the hardware modifications were implemented during the 2013-2014 shutdown. Studies on OTR emission started as planned in the second run of 2014, with initial encouraging results. The characterisation of the wake-field monitors in the TBTS was also carried out demonstrating a resolution in the few microns range, well within the CLIC requirements.

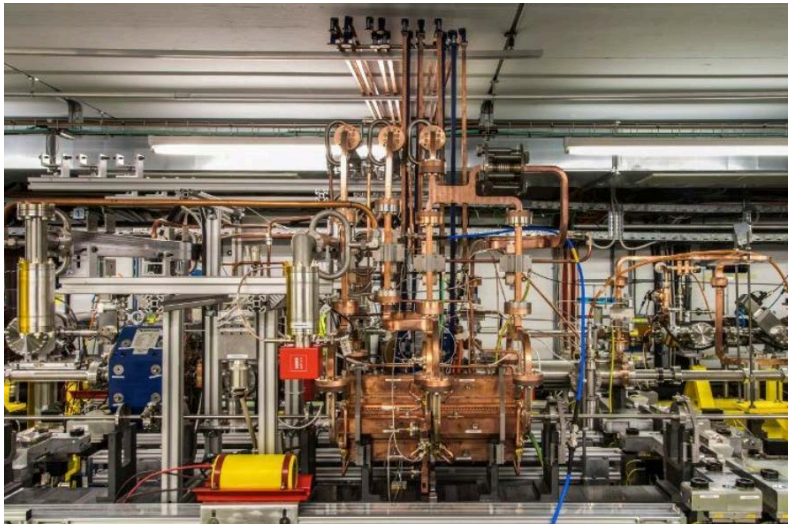

**Figure 42: The CLIC Two-Beam Module installed and commissioned at CTF3.**

The CLIC parameters optimization for cost and power reached a milestone in 2014, with the choice of the energy and luminosity targets for the initial stage, and the definition of the upgrade path strategy towards the final 3 TeV c.m. energy. Optimum parameters for beam and structure have been identified as well. Collaborative studies on the potential use of CLIC high gradient technology for compact X-FELs continued and a consortium was formed to bid for an EU co-financed design study. In spite of the good marks, the proposal was not granted funding; however the collaborating institutes agreed to proceed according to plans using internal funding. Dedicated studies on potential for X-band technology use in medical and industrial applications, jointly with key industrial partners, were intensified.

CLIC's collaboration with KEK's ATF2 accelerator test facility has been considerably strengthened in 2014. The two new octupoles for ATF2 are under fabrication, as well as their alignment system. ATF2 ground motion studies were very successful, among other things leading to the identification of a vibration source that could be removed via a hardware intervention. The CLIC collaboration continues to strongly support ATF2 activities and ultra-low  $\beta^*$ , ground motion and wakefield free studies were a priority in the 2014 December run. Other advancements in the beam delivery system area includes finalization of an alternative "traditional" final focus design with considerably easier tuning, and progress with two beam FFS simulations and with the analysis of ATF2 data. The collaboration with the Australian synchrotron on low emittance tuning and new measurement techniques continued and results were documented. The agreement between CLIC and Spanish institutes including experimental tests for Damping Ring stripling kicker prototype and pulser in ALBA was signed. Additional experiments work in the damping ring area includes an experimental programme at the Cornell's CESR Damping Ring Test Accelerator on instrumentation (a new proposal for halo monitoring), e-cloud, and measurements for ion effects.

Wakefield Free Steering was tested in FACET with very good results. A measure of transverse long-range wakefields in a CLIC accelerating structure was also performed at FACET. The experiment was fully successful, showing unprecedented precision and accuracy. The measurement verified that the strict requirements for CLIC are indeed met and measured data were also remarkably close to 3d simulations results obtained with code GDFIDL, validating the design procedure. Tests of beam based alignment were performed at both Fermi at ELETTRA in Trieste, and at ATF2, in both cases proving that dispersion-free and wakefield-free orbits can be obtained.

## BE-BI Group

Testing of CLIC instruments reached a milestone in 2014 with the installation on the Califes beamline at CTF3 of a cavity BPM test-stand (see Figure 43). Three BPMs were mounted on translation stages allowing them to move both horizontally and vertically for centring the beam within the BPMs. The cavity BPMs are read-out using two stage down-mixing circuitry developed by Fermilab. With such a set-up, the position resolution of the CLIC cavity BPMs will be measured in 2015.

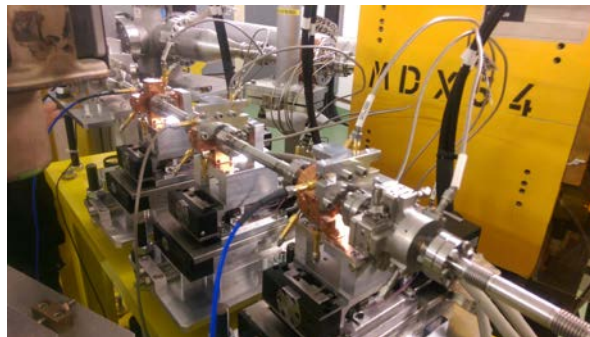

**Figure 43: CLIC Cavity BPM test-stand on Califes at CTF3**

The development of beam loss monitors (BLMs) for CLIC has also advanced on several fronts. Optical BLMs using Cherenkov optical fibres as well as more robust ionization chambers were installed along the CLIC module under-test in CLEX at CTF3. The goal is to understand the capability of BLMs to distinguish losses from the Drive and the Main beam when propagating in the CLIC module simultaneously. Initial measurements are expected to take place in 2015. CLIC BLMs have also been installed in the CLIC RF test-stand to measure the induced signals from dark current emission and RF breakdown in accelerating structures. Figure 44 presents the measurements performed with RF input power up to 34MW. Extrapolating this result to the foreseen CLIC RF input power of 60MW, shows that RF breakdown and dark current would have an impact on the dynamic range of any CLIC BLM system. This will now be compared to beam loss simulations to assess the consequences on the capability of the CLIC BLM system to efficiently protect the accelerator.

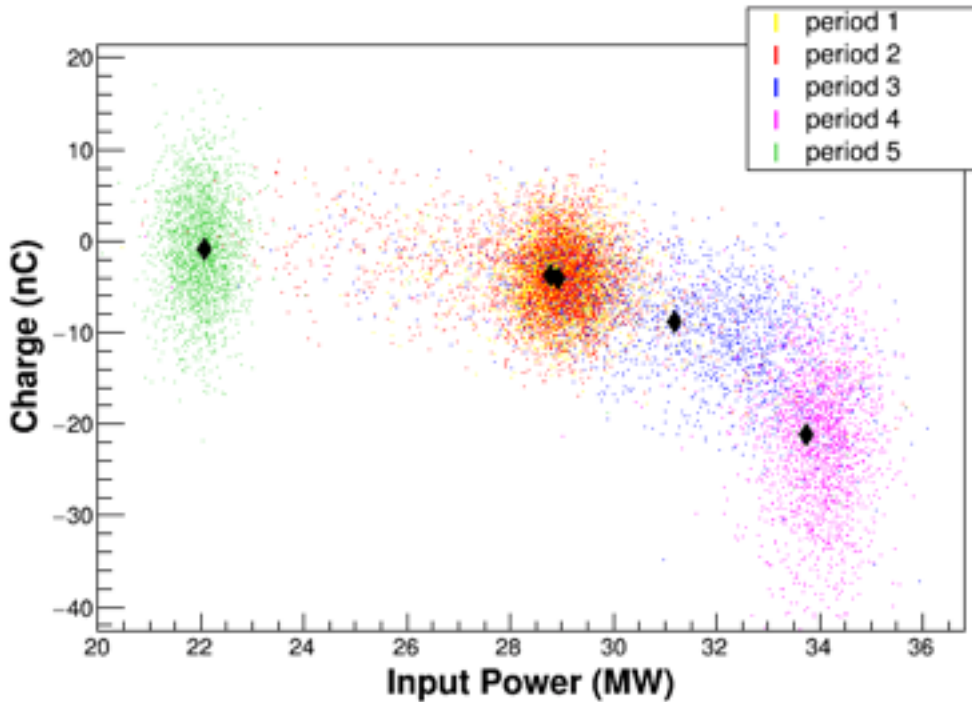

**Figure 44: Measured BLM signal as a function of RF input power in a CLIC accelerating structure.**

Finally, in collaboration with the Royal Holloway University of London and Cornell University, a first non-interceptive beam size measurement was performed on the Cornell Electron Storage Ring (CESR) using Optical Diffraction Radiation (ODR). Figure 45 presents the measurement of 2 GeV electron bunch passing through a 500  $\mu\text{m}$  slit. A vertical beam size of 20  $\mu\text{m}$  was measured in this case.

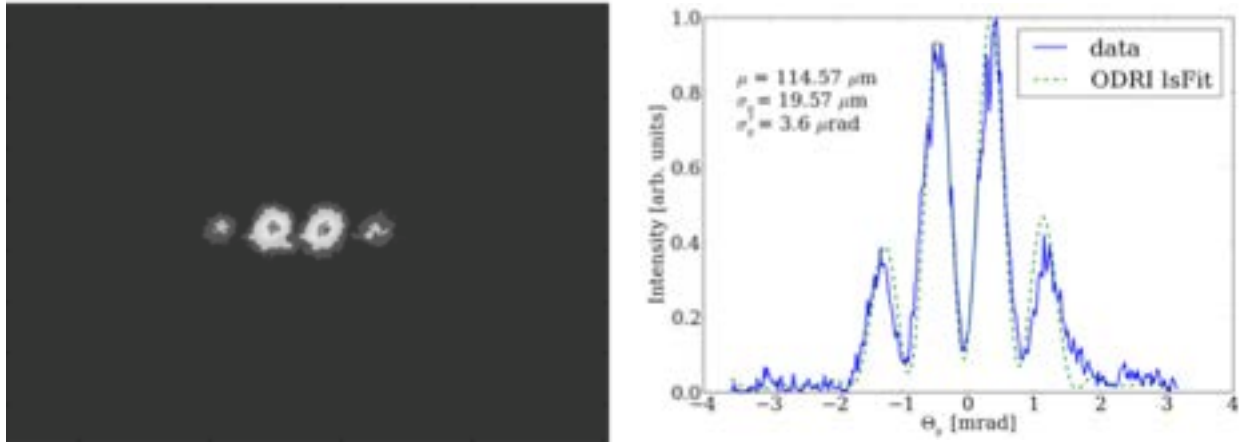

**Figure 45: ODR interferometry image (Left) and corresponding profile and fit of a 2 GeV electron beam with a 20  $\mu\text{m}$  vertical spot size (Right).**

## BE-OP Group

The CLIC Test Facility CTF3 has continued its operation during LS1. The main focus was the consolidation of the full drive beam generation. This factor 8 bunch train recombination was routinely performed at an electron beam current of 28A. A large progress in reliability, stability and repeatability has been achieved by hardware improvements, feedbacks for the machine operation and improved understanding of the machine optics and dispersion.

A new experiment has been installed at CTF3 to measure the effect of the beam loading on the RF breakdown rate. A CLIC prototype accelerating structure was installed in a beam line in the CTF3 linac and powered by a 12GHz klystron. The RF breakdown rate is measured with and without presence of a beam inside the structure. First preliminary results show that the beam presence does not deteriorate the breakdown rate. More experiments are ongoing to quantify the breakdown rate behaviour and breakdown distribution inside the structure in more detail.

CTF3 was stopped during the summer for the installation of the first prototype CLIC x-band module. This installation was successfully finished at the end of October. This big milestone was possible due to a motivated and enthusiastic collaboration between many individuals, groups and services at CERN as well as outside collaborators. Beam operation could be quickly established after the restart.

## BE-RF Group

Within the X-band structure production and testing program, a second TD26CC structure prototype was finished for testing in 2015. TD26CC has become baseline after the good results obtained from the first realization. Four RF structures integrated in the CLIC prototype module installed in CLEX were finished and prepared for installation after several leak repairs, vacuum baking and tuning (cf. figure 42). The team also proceeded with the final preparation of the Crab Cavity issued from a UK-CERN collaboration and the assembly of the last spare structure used as a linearizer in ELETTRA and PSI FEL. The assembly of TD24\_SiC, which includes a new manifold concept with SiC absorbers in the structure also started.

Two-beam acceleration could be studied as well as the sophisticated girder alignment system under beam conditions.

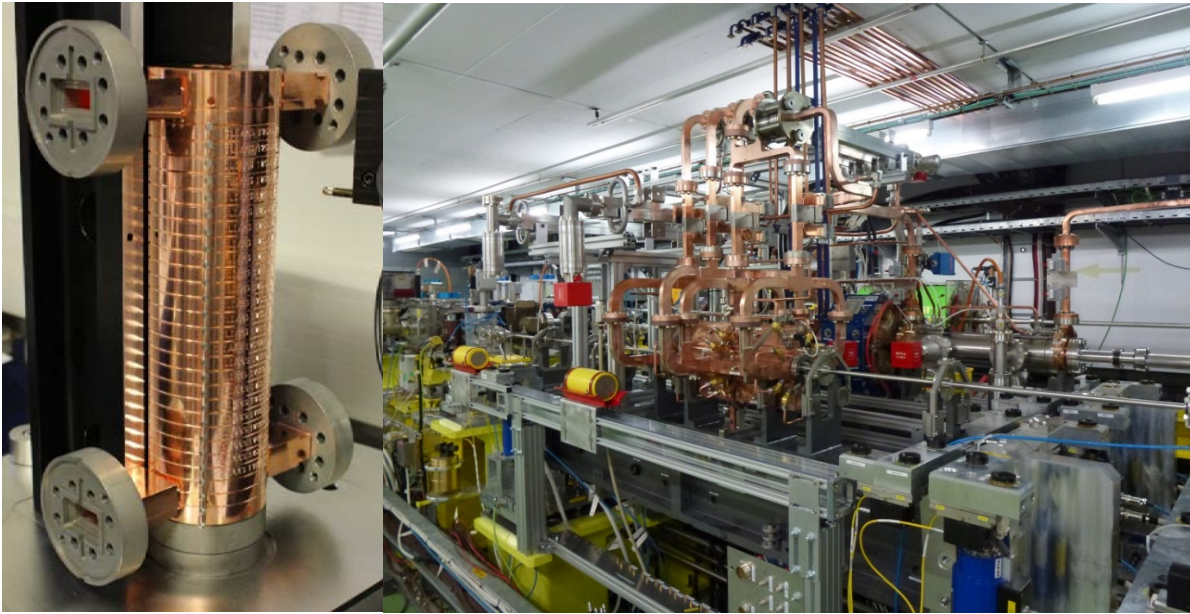

**Figure 46: TD26CC structure (left) and the first CLIC prototype module installed in CLEX (right)**

In addition, CTF3 was operated for a variety of experiments like two beam acceleration, beam instrumentation tests, beam dynamic and beam based alignment studies.

A lot of progress was made in the development of a new electron source for the CLIC drive beam. A thermionic gun capable of producing the long beam pulse for the drive beam was build and installed in a gun test area in Bldg. 162. The gun was successfully high voltage tested up to 150 kV and is awaiting first beam test.

The CLIC module program concluded the thermo-mechanical measurements on a single prototype module with promising results. The set-up is currently extended to a representative three module string.

Another 2014 Highlight was the completion of the installation of XBOX-2, shown in figure 43. BE-RF-FB section provides support for the exploitation of CTF3 as well as for new developments to test 12 GHz structure in the test-stands. Operational support has been provided for XBOX1 and XBOX2 and development of the LLRF systems started for XBOX3 systems.

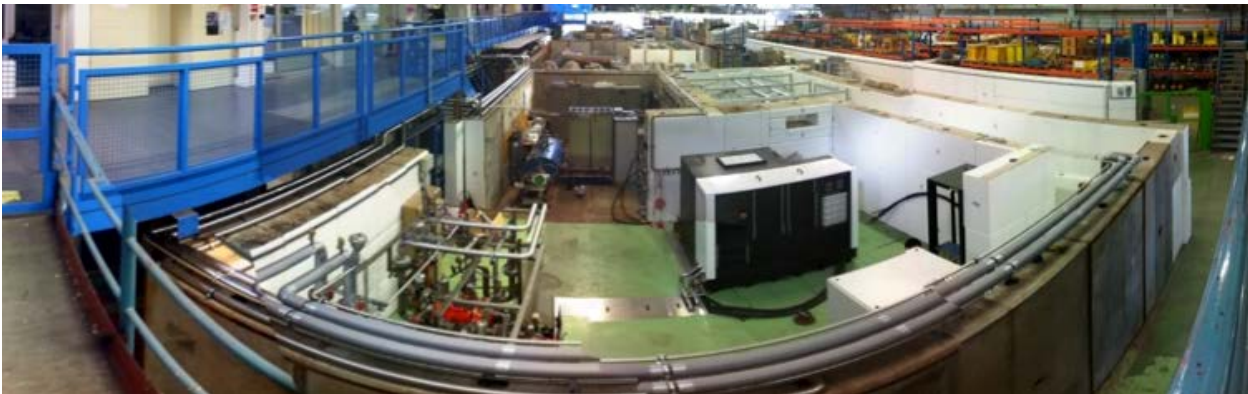

**Figure 47: Fish-eye view of XBOX-2 installed in building 150**

# Neutrino Facilities Studies

## BE-ABP Group

The work on two important neutrino-facilities has continued during 2014: nuSTORM (Neutrinos from STORed Muons), which is a collaboration between US and Europe, and the ESSnuSB (ESS neutrino SuperBeam) which is essentially a European collaboration lead by Uppsala University in Sweden and CNRS in Strasbourg. NuStorm is a small muon race track storage ring where the muons decay in the straight sections of which one is pointing to a near and a far detector. NuSTORM has three main research objectives: neutrino-nucleus cross section measurements, to build a test-facility for muon production, collection and storage, and finally the facility has a potential to discover new neutrinos. There are two options, either to use the FNAL main ring as a proton driver (which is the original proposal) to produce neutrinos from a target, or, as an alternative, to use the SPS beam and build the facility at CERN. The CERN option has been studied by Imperial College and CERN: a work plan has been written with distinct work-packages with the aim to get funding to produce a technical design report (two year program); the report has been made available to the management of the CERN Neutrino Platform.

The linac of European Spallation Source, ESS, has the unprecedented power of 5 MW and such a proton source is very interesting for the production of neutrinos. The linac, having a relatively low duty-cycle, can permit extra pulsing: 28 Hz or higher; for the neutron spallation alone the frequency is 14 Hz. The neutrino target needs short pulses (ohmic heating of the pion collection horn), therefore an accumulator with H- injection has to be added to the facility. The intensity being more than  $10^{15}$  protons per pulse, several ideas how to treat this have been investigated: many ring options or higher pulse rates for example. A first lattice has been designed and a footprint including transfer lines has been laid out on the ESS site. Studies on collective effects are ongoing together with Uppsala University. Several proposals to get funding for the studies of the linac upgrades, the accumulator, the target station and the detector development have been submitted to EU.

## Medical Related Experiments

### BE-ABP

#### A Facility for bio-medical experiments with LEIR "Bio-LEIR"

The idea of BioLEIR is to provide light ion beams in the range from protons to neon to the radiobiological user community. In this context a front end providing light ion beams to LEIR needs to be designed.

One possibility would be to re-use Linac3 with a new light ion source and RFQ. A study was done to define the general design of the light ion beam and the basic structure of a light ion RFQ. A critical element in this design is the switch yard to combine the original Linac3 line with the light ion line in front of the main accelerator structure.

At the beginning of the year all the different possible options were put together in a report and presented to the management. After some discussions it was decided to follow the option to build a complete new light ion linac to be independent of the LHC injector chain and to have some more flexibility concerning beam properties. This linac (already baptized Linac5) could be

installed for example in the tunnel to be vacated by Linac2 when it is removed from service in LS2.

In the context of the light ion production experiments were conducted in collaboration with the Helmholtz-Zentrum Berlin. The aim of these experiments was to gain experience in the production of boron and lithium ion beams.

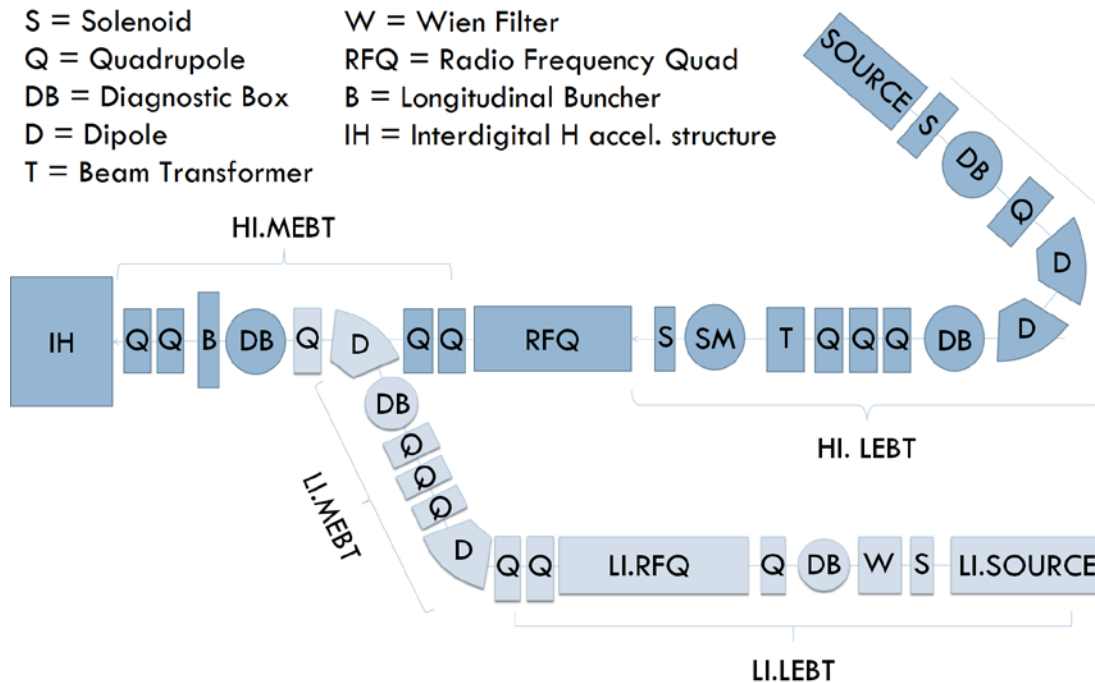

Figure 48: Schema of the present Linac3 front end and the extension for the light ions.

Early in 2014 the ICTR-PHE conference (<http://ictr-phe14.web.cern.ch/ICTR-PHE14/>) brought together the physics, biology, and medicine communities for Transnational Research in Radio-Oncology and Physics for Health in Europe. CERN then established a new CERN Medical Applications office (CMA) to coordinate its activities.

BioLEIR is one of the seven initiatives of the CMA office and was presented and very well received by the ICTR-PHE conference. The studies for this facility centered on the LEIR accelerator made significant progress in 2014. Following a change of name -- it is now called OpenMED.

A small working group is being formed with experts from CERN and other interested institutions to make sure that all necessary studies for OpenMED can be carried out, providing approval and financing are granted, after which CERN could build and make available an installation to carry out fundamental research in the effect of light ion beams on organic tissues and cells, and can develop appropriate methods and procedures for appropriate therapeutic irradiation for treating cancers.

### A high frequency RFQ for a Linac-Based Hadron Therapy Facility

The final layout of a 750MHz RFQ has been defined based on the requirements of a hadron therapy linac operating at 3GHz. The low-current demand for hadron therapy and the higher RF



frequency led to a design of an RFQ which is significantly shorter than the conventional RFQs. In the final design, the protons are accelerated from 40 keV to 5 MeV only in 2m. One of the focuses during the design process was to minimize the particle losses at the transition to higher frequency. This was achieved by optimizing the parameters of the RFQ such that only the particles that fit into the acceptance of the 3GHz linac are accelerated and the others are lost at the lowest possible energy, well below the activation threshold. CERN – KT has been involved from the beginning in this endeavour, and as a result a patent was filed for this device. Currently, the RFQ is being constructed at CERN and the beam commissioning is foreseen during the second half of 2016. The information that will be gathered during the beam commissioning will help to improve the design of the future medical RFQs.

## **BE-RF**

### **Medical HF RFQ**

Studies have started in order to provide four 100 kW, 750 MHz amplifiers, to pulse 20  $\mu$ s at a rate of 200 Hz. Several options have been looked at including SSPA, IOT, klystrons and magnetrons. The technical specification were drafted (limited size, weight and cost). Equally first concepts for the FPCs were developed, based on a scaled version of the Linac4 windows.

### **MedAustron**

CERN delivered the PSB-style digital LLRF system and the Finemet®-based cavities to the MedAustron in Wiener Neustadt in Austria. Subsequently, first capture was reached in May and extraction to the treatment hall IR3 at nominal energy in November.

## **Future machines and EuCARD**

## **BE-ABP**

### **FCC**

In response to the 2013 Update of the European Strategy for Particle Physics, the Future Circular Collider (FCC) study was launched. The FCC kick-off Meeting at the University of Geneva in February 2014 was attended by more than 340 participants. The FCC study covers the designs of a 100 TeV hadron and a high-luminosity lepton collider, the associated detectors and physics studies, and even a lepton-hadron collider option. These rather generic and mostly site independent studies are complemented by a civil engineering study for the Geneva area. The global FCC collaboration is organized as a consortium of partners based on a Memorandum of Understanding. By the end of 2014 more than 30 institutes from around the world had formally joined this collaboration. A preparatory FCC Collaboration Board meeting was held at CERN, with about 80 participants (1 representative per institute).

An FCC Horizon 2020 Design Study Proposal “EuroCirCol,” addressing the key elements of the hadron collider (conceptual design of arc & interaction-region optics, feasibility of key technologies, implementation), was prepared and submitted to the European Commission in September 2014. Initial accelerator studies in 2014 included the definition of baseline

parameters, optics designs for hadron and lepton colliders, assessment of hadron injector options, staging scenarios for the lepton machine, and synchrotron radiation issues.

## **EuCARD**

During the year 2014, the various accelerator networks of EuCARD-2 organized or co-organized a total of 23 workshops, many of which on fundamental topics for the future of particle accelerators. Most active in this regard was the network “Extreme Beams”, whose events related to the upgrade of KEKB in Japan, to crystal channelling, to the understanding and mitigation of multipacting, to circular lepton-collider “Higgs factories,” and to the future of the CERN facilities. With respect to the latter, not only various upgrades of the LHC were considered, including HL-LHC crab cavities and a lepton-hadron collider option (LHeC), but the Extreme Beams network participated as well in the launch of a new study for a challenging 80-100 km collider, the “Future Circular Collider” for protons and possibly electrons, which could become the leading accelerator for particle physics after the end of the LHC lifetime. Other workshops like “Beam Dynamics Meets Magnets” brought together diverse communities to facilitate magnet optimization; prepared the commissioning of proton linacs, with emphasis on the ESS; and synthesized the key questions for lepton spin polarization to be addressed in the coming years.

EuCAN is coordinating the activities of the various networks within EuCARD-2. A EuCAN Workshop "Universities meet Labs" was organized in Frankfurt am Main / Germany. Themes included the training & accelerator schools across the world, students between research centres and academia, collaboration of Universities and laboratories, research ranking in different countries, journals, impact factor, Hirsch index, physical societies & status of accelerator physics, funding/collaboration initiatives, e.g. in Germany & Hessen (LOEWE, FIAS, Helmholtz Institutes, KFB, DPG AKBP) and also in Spain (CONNECTA), Frankfurt accelerator facilities (including a tour), funding, and the progress of the EuCARD-2 networks.

## **BE-RF**

### **Awake**

The AWAKE project will require a synchronized extraction of a proton bunch from the SPS in LSS4 of the SPS with respect to a LASER pulse generated in the experimental cavern and in the second stage to the electron beam of generated locally. The conceptual design of the synchronization of this three beam system has well advanced and resources have been estimated to start implementation in 2015, mandatory as commissioning of the plasma cell with beam is foreseen for 2016.

The electron source and accelerator for AWAKE based on the PHIN photo-injector has been designed and its challenging integration into the former CNGS area has been studied. The performance of the accelerator has been simulated and seems to fulfil the requirements.

## **Other Group Activities and Cross Departmental Activities**

### **BE-ASR Group**

The Administration, Safety and Resources (ASR) group is a service group to the Beams Department. The group is mandated to provide overall assistance to the department head, to each individual group and to each and every member of personnel in the department. The heterogeneous services are to be delivered in the smoothest and most unobtrusive way while minimizing the inevitable overhead associated with administrative work, resources planning and control, and Safety.

Specific responsibilities concerning human resources and administrative matters, have been mandated to the BE-ASR group leader, by delegation of the department head. Departmental representation is hence ensured in staff selection committees, the CERN contract review board, and the Standing Concertation sub-group dealing with modifications of the Staff Rules & Regulations, Administrative Circulars and Operational Circulars.

In order to overview, plan and control all resources – human as well as financial – within the medium term period, the ASR group leader has also the role and the full responsibility as Departmental Planning Officer (DPO).

### **The BE Newsletter**

Another three issues of the BE Newsletter, introduced in 2011, were published in 2014. The content varies widely from scientific and technical to practical, social and safety information, provided by each group via its correspondent. The management, compilation of all contributions and final editorial work is in the hands of BE-ASR. A dedicated column on “life in BE” is devoted to contributions of newcomers reporting on more lightweight subjects and personal impressions.

### **Administration & Secretariats – BE-ASR-AS**

The Administration and Secretariats team is tasked with ensuring an effective and high quality administrative assistance for Group Leaders and Section Leaders, as well as providing an administrative support for all categories of personnel for a wide range of activities. The team of eight group secretaries and departmental support in the Central Secretariat (DAO, DDAO) is geographically split between the Meyrin and Prévessin parts of the CERN site and located in different buildings. The recurring activities of the assistants start from the welcoming of new arrivals (280 in 2014!), ensuring that they all are allocated an appropriate work space. The management and follow-up of staff contract extensions, transfers, secondments, contract terminations and departure formalities (257 in 2014!) is voluminous due to the increasing number of associate members of personnel. Since 2014, the follow-up of special paid leave for doctoral students and payment of travel expenses for their university supervisors, requires an extra workload and careful attention.

Of particular importance also is the coordination of selection committees for Fellows as well as Doctoral, Technical and Summer students. The central secretariat is also involved in the follow-up of induction interviews, mid- and end-probation reports, the coordination of the MARS exercise as well as all actions related to advancement, promotion and awards of staff members, treatment and monthly control of overtime, shift work and stand-by duty. In the groups the secretaries assist the CERN personnel with arranging official travel and calculation of reimbursements, treatment of reimbursements of education fees, management of subsistence

fees, control of absences and third party claims. The secretaries also provide assistance with the administrative organization of events and conferences (e.g. LINAC14, LHeC, Finemet Review, ICFA), the creation and update of group websites and documentation systems and the coordination of visits onsite, especially in the CCC.

The Departmental Administrative Officer (DAO) collaborates proactively and continuously with the HR department and the Legal Service to streamline and improve the administrative procedures, making sure to implement correctly and efficiently the revisions of administrative circulars and contributing to the pragmatic documentation of the [CERNAdmin e-guide](#).

Since the introduction in 2013 of new statutes such as Cooperation Associates (COAS) and Visiting Scientists (VISC), the related administration has been substantial. The search for existing agreements, creation and verification of new agreements with the Legal Service, the Procurement Service and supervisors are time consuming activities. The management and the follow-up of payment of subsistence for these categories of personnel is also an important monthly activity. For the year 2014, 67 COAS and 37 VISC were registered.

### **Resources & Logistics – BE-ASR-RL**

The main tasks of the Resources and Logistics team are to provide assistance to the Departmental Planning Officer (DPO) and his deputy (DDPO) on budgetary and financial matters, and to the Departmental Space Manager (DSM) for space and storage management, follow-up of small works and related logistics. The *financial and budget related activities* concern primarily monitoring and reporting on material budgets for all BE Groups and projects, monitoring and follow-up of the invoices and yearly accruals, maintenance of budget codes and signature rights. This includes externally funded budgets such as EU projects and the collaboration for the HIE-ISOLDE project.

The activities of *space management* continued to be challenging. The strategic and operational activities are intertwined, due to a minimalist coordination team of 1.2 FTE: the Departmental Space Manager (DSM) from BE-ABP, his deputy (BE-ASR GL) and the DSM Assistant. Nevertheless, significant progress was made on the space rationalization of offices, labs and storage areas and to record the information correctly in the central information system GESLOC. The DSM, as member of the *Groupe de Travail sur le Partage de l'Espace* (GTPE) actively contributes to the CERN-wide space management.

In view of the move of the BE-CO group and the BE Head Office to the new Prévessin main building 774, the DSM negotiated with his counterparts a redistribution of space between BE, EN and TE. The implementation of this plan involves substantial movements, mainly in the buildings 864, 865 and 866 on the Prévessin site. Due to delays in the construction and availability of the building 774, the planned moves have been postponed and will not take place before early 2015.

The departmental *logistics* includes the management of keys and cylinders (419 requests), management of the departmental car fleet (69 vehicles), the departmental inventory of equipment, the monitoring of the use of telephones, management of photocopiers and office and workshop furniture. The CERN-wide car-sharing is strongly promoted and increasingly used for the mobility of personnel. For the transport of personnel with equipment and tools, we have started to put in place departmental car pools in order to optimise the resources. The dedicated LS1 vehicles will be returned in due time as well as additional ones that will not be renewed in line with the instructions to reduce the overall car fleet by 12%.

The Departmental Training Officer (DTO) – actually in BE-RF, his deputy being in BE-ASR – monitors a rigorous departmental strategy, in line with the *Learning & Development Policy*, on communication (news and reporting), training request authorisations and budget follow-up.

Target levels for language courses, justified by the staff member's supervisor, are now imperative before acceptance by the DTO.

This year, a dedicated Section Leaders Workshop replaced the annual BE Workshop. Eleven section leaders were invited in order to allow them to learn from each other and share "*best practices*", facilitated by HR.

### Safety Unit – BE-ASR-SU

The staffing of the BE-Safety Unit was stable in 2014 with seven staff and one fellow, for a total of 5.6 FTE, and apart a new fellow, there were no major changes.

The Nuclear Safety Officer of the Safety Unit remained involved in the CERN **Crisis Management Team**. The Organization is now well prepared to react and manage a crisis. A second crisis-management room is now equipped and available, located on the Prévessin site in the proximity of the CCC.

#### Safety of Personnel

The Safety officers continue to maintain frequent and positive **communication with the TSOs**. In particular, discussions were conducted with them to adapt the mandate of the BE TSOs from the General Safety Instruction GSI-SO-2. This pragmatic mandate was approved by the Management and should ease the work of the TSO with the empowering of their function.

A **Safety Link Person (SLP)** is now nominated in each BE Group. The mandate of the SLP is adapted from the GSI-SO-3, and the SLP will be the entry point for safety issues for his Group.

The new **safety-training** scheme defined and approved in 2013 was introduced in 2014. New courses to access beam facilities were finalized: Beam Facilities (mainly by HSE), LHC, and SPS (both by BE), as well as for the AD-target (by EN). The need for new courses was identified and consolidated with access managers. The Safety Unit has defined a process for proper quality assurance during the design of the courses, and is offering help to authors.

Three building **evacuation exercises** were organised in 2014. One of these buildings is part of a complex of seven interconnected buildings for a total surface of 8400m<sup>2</sup>. The exercise involved four Departments and some sixty participants. Additional emergency guides have been trained for their responsibilities during evacuations and the manipulation of fire extinguishers.

The Safety Unit proposed a standardized panel to be placed at the entrance of beam facilities, to inform people about the Personal Protection Equipment (PPE) to be worn upon entrance. The panel design was discussed with DGS-RP and the DSO of the EN Department, and in agreement with the graphic chart of CERN. The panel will be deployed by EN-MEF.

Concerning **accidents/incidents** at work, the BE figures are generally lower compared to other technical Departments. The increase of the number of reported commuting accidents continued in 2014. This remains a major concern, but the higher number is also due to a better reporting of accidents, which reflects an improvement in the safety culture.

#### Laser Safety

The Laser Users **training course** designed in 2013 became effective in 2014. Laser Safety Officers (LSO) provide hands-on exercises in the dedicated training room now commissioned at the training center on the Prévessin site.

The cross-departmental panel of LSOs is now exchanging information and best practices. This offers a better visibility on laser safety, gradually all lasers are registered in the database and Users have a better **proactive behavior** in contacting the panel members for advice before their installation.

## Radiation Safety

The **DIMR** (*Dossier d'Intervention en Milieu Radioactif*) was reviewed in 2014, and a document to improve the process and the form itself has been written jointly with DGS-RP and the Radiation Safety Officers (RSO). The aim is to improve the management of radioactive work and provide a better visibility to RSOs.

The **TREC** project (*Traceability of potential Radioactive Equipment at CERN*) has almost been completed. At the end of 2014, three out of thirty-seven Buffer Zones were equipped with TREC computers and were operational with the unified access control (with dosimeter).

## Safety of Installations

In view of a safe **restart of injectors** after LS1, the commissioning of the new access system deployed around the PS Complex was followed up by the Safety Unit. The some 20 DSO tests still revealed some non-conformities, but they were more linked to EIS-beam and EIS-machine rather to EIS-access. This pointed to the need of the revision of the beam-permit process. New processes such as cool-down clearance and powering permit, including the verification of the tightness between the LHC tunnel and the experimental caverns.

Following the approval in 2013 of the generic **quality assurance** procedure for the management of the EIS (*Eléments Importants pour la Sécurité*), the identification of EIS in the field has progressed in 2014. Equipment groups started to write specific procedures for intervention on and maintenance of their EIS. This increases their reliability.

Before the start-up of the **North Area**, the protection system to protect people in EHN1 against high proton intensity beams in **ion mode** has been commissioned, validated, and can be put in operation.

The procedure for the proper use (by BE-OP, EN-CV and GS-FB) of the **ventilation doors** of LHC Point-7 has been finalized, and its use will be monitored to learn from experience.

Several **Risk analyses** were performed for new projects and installation such as XBOX2 and GIF++. The start-up of the latter, together with the implementation of safety measures, has been properly monitored.

In April 2014, a working group was mandated by the Director of Accelerators to better define the expected content of the **Safety Files** and the process of their elaboration. The BE DSO is part of the working group, of which the progress is reported to the editors via the editors club, chaired by the BE Deputy DSO. Within the framework of the LIU project (of which the PSO is our Quality Assurance Engineer), the members of the Safety Unit have started to write the Safety Files of all injectors (Linac4, LEAR, PS, PSB, and SPS).

The three **Complex Safety Advisory Panels** (CSAP), have set-up working groups or sub-panels to study specific safety issues (e.g. the ventilation WG). Members of the BE Safety Unit are

## BE-ABP

### Beam Physics Codes

In 2014, MAD-X was still under strong consolidation with numerous bug fixes and enhancements, leading to an unprecedented level of stability for the application. By the end of the year, the 64-bit version became the default on the CERN's central linux computer service LXPLUS, providing some speedup, and the memory footprint was halved to support complex studies run on large machines like HL-LHC and FCC. Few new commands were added to improve the portability across platforms, making easier to share scripts within collaborations.

The user's guide has been completely restructured and published on the MAD-X website, and kept synchronized with the releases. In March, the MAD team delivered the second production release 5.02.00 since it took over in 2011.

The code was extended to support the thick symplectic map for dipole magnets as part of the improvement aiming to simplify the transition between optics design and beam dynamics studies. The tracking module and the slicing modules were extended to allow mixed thin and thick tracking, as well as supporting parallel tracking on multicore CPUs.

As far as SixTrack is concerned, in 2014 a module for generic dynamics effects have been introduced in the code in order to study failure scenarios and noise effects. A revision of the beam-beam lens and wire elements have been started to match the simulation requirements of the HL-LHC project. In parallel SixTrack participated in the Google Summer of Code programme and obtained the sponsorship of two summer students who contributed to post-processing tools for long term tracking simulation and to a portable C library that implements the SixTrack tracking engine to be used alone or incorporated in other simulation suites.

## Workshops

An ICFA Mini-Workshop on “Electromagnetic Wake Fields and Impedances in Particle Accelerators” was held in Erice (Sicily) from April 24th to April 28th, 2014. It was hosted by the Ettore Majorana Foundation and Centre for Scientific Culture and sponsored by the CERN LIU and HL-LHC projects, INFN, EUCARD-2 and XBEAM. The workshop was attended by 52 accelerator physicists from all around the world and all the relevant information can be found on the web site: <http://indico.cern.ch/event/287930/>. This workshop was dedicated to A.M. Sessler, who passed away just before the workshop on 17/04/2014.

Together with V.G. Vaccaro, A.M. Sessler introduced the concept of impedance in particle accelerators. The first mention of this concept appeared on November 1966 in the CERN internal report “Longitudinal Instability of a Coasting Beam above Transition, due to the Action of Lumped Discontinuities” by V.G. Vaccaro. A more general treatment of it appeared in 1967 in the CERN yellow report “Longitudinal Instabilities of Azimuthally Uniform Beams in Circular Vacuum Chambers of Arbitrary Electrical Properties” by A.M. Sessler and V.G. Vaccaro. The concept of wake fields came two years later, in 1969, in a paper from A.G. Ruggiero and V.G. Vaccaro (The Wake Field of an Oscillating Particle in the Presence of Conducting Plates with Resistive Terminations at Both Ends). This was the beginning of many studies, which took place over the last four decades, and today, impedances and wake fields continue to be an important field of activity, as concerns theory, simulation, bench and beam-based measurements.

## BE-BI Group

As agreed with the Accelerator Controls Renovation project (ACCOR) the emphasis for renovating BI front-end systems during LS1 was given to the LHC. More than 100 front-end CPUs including the large distributed BPM and BLM systems were upgraded to the MEN-A20 type, with the front-end software ported to Linux. During this migration several issues with hardware compatibility of control signals on the VME bus were discovered. A lot of time was therefore spent in understanding the fine details of these problems, most of which were solved in collaboration with experts from BE/CO. The complete controls renovation for the more than 300 BI front-end systems is expected to last well into LS2.

## BE-CO Group

## The Layout Service in the A&T Sector

As a central point of reference for numerous aspects of the accelerator complex, the Layout Service continued to be heavily solicited throughout 2014, for the capture, update, and propagation of data to reflect changes due to the various installation and renovation activities during LS1.

The Layout Service is now more than 10 years old. During this time, its philosophy of providing support for centralised, integrated functional position data has not changed. However, its purpose, geographical scope and domain scope has expanded enormously, from just managing LHC beam-line elements, to potentially any functional position which has an impact on accelerator operation, in any beam line at CERN. With its generic database design, lack of associated tools and reliance on the expert domain knowledge of the Layout Service members, it was clear that the service was becoming increasingly unsustainable. In 2014 a concerted effort was made to kick-start the development of the new database, which should be in place by the beginning of LS2. Significant progress was made by the end of the year, with the core database model almost completed, and hourly data synchronisation from the existing Layout production database in place.

## The Logging Service across CERN

2014 saw a significant increase in logging activity during 2014, as accelerators were restarted, and various LHC sub-systems were re-commissioned. The chart below shows how daily storage rates increased well beyond the maximum values of Run1, despite no beam in the LHC. This was mainly due to an enormous increase in QPS data. Despite the increases, the Logging Service was fully available and stable throughout the year, and heavily relied upon to support many activities.



**Figure 49: Daily evolution of the Logging Storage used (data logged)**

The Logging team continued the work of re-factoring the data extraction API (used by close to one thousand people), in order to consolidate and build a more flexible and scalable platform, upon which various requested data analysis related functionality can be added in the future.

Meanwhile, a significant effort was made to develop and tune a new database-to-database transfer mechanism to allow the EN-ICE teams to send the data acquired via the SCADA systems in their new database-based archiving (was previously file based) to the Logging Service database. This required a lot of collaboration, and performance tuning to scale to the new demands of the upgraded LHC QPS. The efforts paid off, and everything was soon working smoothly.



## CMW - Controls Middleware: RDA, RBAC, JAPC, Tracing and JMS

In 2014, most efforts were spent in consolidation of the new RDA3 library and its integration with major CERN controls frameworks, including: FESA, FGC, PVSS/WinCCOA/LabView, PM & C2MON/TIM/DIAMON. In spring'14, FGCD framework was deployed operationally in all Injectors using for the first time RDA3 server-side framework. Next in June'14, new major version of FESA3 2.0.0 was released, fully based on RDA3 framework. All major CO systems (e.g. LSA/InCA, Logging, SIS, Sequencer, OASIS, CESAR) are RDA3 compliant thanks to the new JAPC-RDA3 extension, which provides the integration layer with RDA3 client library.

During spring'14, CMW Proxy service was upgraded and extended in order to be able to connect to new RDA3 servers, e.g. FGCD & FESA3/RDA3 servers. Two types of Proxies are supported: RDA2 client to RDA2 servers and RDA2 client to RDA3 servers. The latter Proxy type is often used in operation to provide connectivity for old, RDA2-based client applications, which need to connect to new RDA3 servers. New Proxy type was one of the major success factors for quick and smooth introduction of new RDA3 servers. It was used for majority of FGCD gateways once they were upgraded to RDA3.

In 2014 the Tracing service was consolidated and optimized in order to cope high frequency of log messages sent from many sources, mainly FESA3 classes. For this purpose, a DNS load balancer was setup in order to spread the load among 2 CMW log servers (converters). The service proved to be very valuable, especially for front-end developers, providing means for easy debugging and monitoring operation of front-end classes running on diskless front-ends. Tracing service was adapted to provide log & diagnostic data to Logstash/Elasticsearch/Kibana (replacement of Splunk) analysis server.

In Q2'14 & Q3'14 several new extensions were implemented and deployed in the Directory Service. The most important one was related to handling of new RDA3 clients and backward-compatibility for old RDA2 clients. Thanks to this new extension, the Directory Service was able to redirect old RDA2 clients to a dedicated RDA2->RDA3 Proxy, however at the same time new RDA3 clients were getting direct connection to RDA3 servers. This extension was necessary for smooth introduction of new RDA3 servers into mixed operational environment with both RDA2 & RDA3 clients.

The Controls JMS infrastructure remained very stable in the year 2014 and the new version of ActiveMQ was deployed in production at the end of the year. This new broker version clearly improves the monitoring and diagnostic capabilities. The JMS infrastructure consists of: 33 production brokers and 7 test brokers deployed on 23 machines. In general, the amount of transported data ranges between less than 1KB to peaks of 56MB in size for a single message, 5000msg/sec for processing speed and more than 9000 client connections.

## CESAR

During 2014, CESAR (the control system for CERN experimental areas) was fully modernised, leaving only the graphical parts unchanged. The new implementation was based on the Disruptor library, originating from the trading world, known for its high performance and simplicity in event processing. The new design allow to streamline the behaviour and enrich the functionality provided by CESAR to experimental area physicists. An example can be seen below: a screen giving the physicists an overview of all the problems preventing the beam from reaching the experimental areas.

CESAR is used in the SPS North Experimental Area where CESAR since a long time. In 2014, it was also deployed for the PS East Experimental area, greatly facilitating the startup for the liaison physicists.

## Towards a successful recommissioning and restart after LS1

The dry runs organized by Controls were one of the main success factors for successful recommissioning in early 2014.

CO took a leading role at the Sector level, to coordinate all controls developments done by equipment groups, and to organize a systematic recommissioning.

More than 50 dry runs organized, as part of the official schedule.

A typical dry run required dedicated time in the accelerator schedule, the presence of developers from CO, and/or equipment groups, and a member from OP to do the acceptance.

The dry runs were organized by the Machine Controls Coordinators (MCCs), who prepared and documented several tests ahead of each dry run. These tests were meticulously executed, and the outcome documented. Every dry run was debriefed, and all individual problems were registered and followed up in JIRA, the issue tracking system. Over 320 issues were tracked during the recommissioning phase alone.

Once the accelerators were operational again, the Controls Exploitation Manager (EXM) took a leading role in handling all controls-related problem. This contributed to the successful move from a dedicated CO piquet to a best-effort support system. In particular:

Frequent presence in the CCC with continuous interactions with the operations team

Organization of first-line support teams. Every controls machine has an operational responsible displayed in DIAMON and the first-line support teams were announced in web-piquet tool

Organization of Monday Afternoon Meetings to follow up controls issues

Representing CO in OP meetings (FOM, PSS, IETF)

Coherent and pervasive tracking of issues with JIRA. Operations were encouraged and given tools to create issues in 2014. In 2014, a total of 1060 issues were filed by operators and dispatched and followed-up by the EXM. These issues spread across 8 groups, involved in equipment controls, as the scope of the EXM coordination had been extended to all controls groups at sector level.

Several tools were prepared for the organization of the recommissioning and Controls exploitation management above:

The Confluence Wiki system on which Dry Runs were prepared and the outcome documented

The JIRA issue tracking system, needed to track, dispatch and follow-up all problems

Both systems were customization as needed for dry-runs and exploitation management by the EXM.

## DIAMON and LASER

2013 was dedicated to develop and deploy the replacement of the LASER tool by integrating the alarm function inside the DIAMON tool. It is under validation process by the Technical Infrastructure (TI) operators before a future deployment for the injectors and LHC.

The DIAMON tool, heavily used in operation as well as by the equipment experts, has been updated with several new functionalities, such as checks to validate deployed driver/firmware versions in the FrontEnds, FIP bus surveillance and alarms, network connections checks (ping), monitoring adapted to the type and functionality of the computer monitored, ...

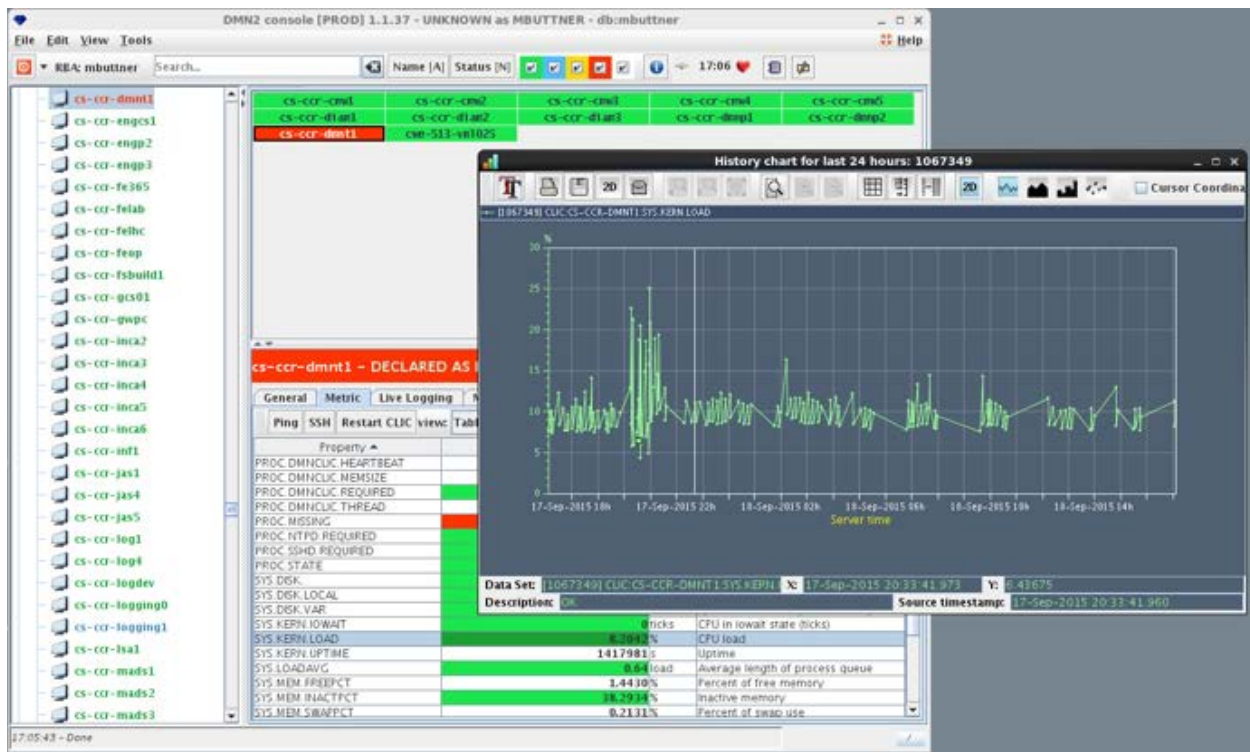

Figure: 50. DIAMON GUI displaying the CPU load history for a specific server

## Controls Diagnostic Tools

The new exploitation model replaces the CO Piquet with a best effort expert support, and also intends to involve operators and equipment group experts into first-line diagnostics. Therefore an investment in better diagnostic tools was made. In 2014, it yielded the two new tools; a Network Connection Viewer and a Proof-of-concept version of a centralized tracing system.

## The Network Connection Viewer

The accelerator controls is a complex distributed system with thousands of computers and processes and several 10'000 of connections in between. The Network Connection Viewer shall visualize these connections, and help with troubleshooting. It is an extension to existing diagnostic tools such a DIAMON, which shows the state of these computers and processes, not the connections between them. The Network Connection Viewer shall help in several ways. It shall facilitate troubleshooting, because it shows how different systems depend on each other. For instance, if a GUI application in the control room does not receive any data, the connection viewer shows which middleware JMS broker the GUI is connected to. It shall help preparing for smooth upgrades, e.g. when classes are upgraded from FESA2 to FESA3. In this case, all connected client processes on other machines need to be restarted, and these clients are visible in the Connection Viewer. Finally, the Connection Viewer shall help to uncover unknown dependencies between processes, with the ultimate goal of simplifying the control system.

## Proof-of-concept version of a Centralized Tracing System

Each and every process in the controls system, and the computer they run on produce log files. These files contain valuable information for troubleshooting, like the activity of processes and

computers and potential problems they suffer from. So far, however, this information was dispersed in various locations on the file system and therefore difficult to find, and difficult to correlate.

A new system was installed, configured and customized that collects logfiles in a centralized searchable database with a user friendly Web interface. It is based on 3<sup>rd</sup> party open source projects: ElasticSearch, a full-text text search engine, and Kibana, a web interface that allows users to search through logfiles and to create dashboards for specific sets of data. At the end of 2014, this centralized tracing system received data from all operational Linux machines, FESA classes, FGCs, middleware servers etc.

The next steps will be to turn this proof-of-concept version into a reliable operational service that receives data from all operational software processes in CO, including Java middle-tier servers.

### **Issue Tracking, Software Development, and Quality Assurance Tools**

A series of Controls tools dedicated to Issue Tracking, Software Development, and Quality Assurance are heavily used across the whole Accelerator Sector. They include the JIRA for issue tracking and planning, Wikis for documentation, Bamboo and the CO testbed for continuous execution of integration tests of the Java, FESA and CMW software, Fisheye and Crucible for searching through and reviewing the source code.

The user community and importance of most of these tools grew considerably in 2014, mainly driven by its use for exploitation management. JIRA doubled to 400 unique users. Crucible code reviews almost doubled from 40 to 80 reviews/month. Developers participating in code reviews increased by 50% from 40 to 60. A very large number of integration tests were executed by Bamboo. The use of JIRA and Wikis has gone well beyond their initial scope of being tools for software developers – it is now used to track operational issues, and for operational documentation e.g. for checklists used by TI operations.

Most of the above services are provided by commercial tools of Atlassian. These tools are configured and customized and upgraded on regular basis as part of the day-to-day user support. Each of the five Atlassian tools needs to be upgraded once or twice a year, and an upgrade to a new version of JIRA requires 1-2 weeks. This comprises thorough validation, backup and restore of the valuable user data, and troubleshooting any problems with Atlassian user support.

In addition to this continuous activity, several specific improvements were done in 2014 to improve security. The Atlassian tools were switched from using http connections (where passwords go over the network in clear text) to https (where passwords are encrypted). Continuous service monitoring was set up to cope with higher criticality of these Atlassian web services. A monitoring program simulates requests from users, automatically checks that the servers respond with meaningful contents, and alerts the service responsible if something goes wrong. In other words, the support team can intervene proactively, possibly fixing a problem even before the users notice it.

### **System administration and Security**

In early 2014 the SAM project (for “System Administration Modernization”) was launched. Its purpose is to get rid of tools and habits stemming from the nineties and replace them with modern tools and techniques used in industry.

One of those tools is Ansible, used to automate system administration tasks. It was chosen because it is simple to learn and set-up, and because it is written in Python, a language already used in the accelerator sector. Another tool is Git, a version control system that makes it possible to track and revert every small change done to the system administration scripts and configurations.

During 2014, all 700 consoles and back-end servers were migrated to Ansible. This is a first step in a longer journey to unify all management of our infrastructure (users, hosts, filesystems, etc) under Ansible and Git. A lot of work still lies ahead due to the amount of legacy code and configuration.

Another form of legacy was removed in 2014. All HP-UX machines were disconnected from the network at the end of 2014. This is the end of an epoch (the “Helix Project” to eradicate all HP-UX machines was announced in August 2000) and as such a late but nevertheless remarkable completion of a legacy removal project.

Regarding the Front-ends, the Controls sysadmin team has made progress in several areas. They have prepared an initial environment of CC7 Linux, which is the successor of SLC6. Getting CC7 to run with a real-time kernel on the Front-end hardware is a special challenge that has to be tackled upfront. As part of the same effort, the process of preparing these SLC6 and CC7 front-end environments has been automated, and the Git version control system has been used to capture all related changes.

Finally, the sysadmin team has participated in a collaborative effort for the testing and preparing the new Front-End hardware platform (Kontron PCI-762 front-end).

The last work item worth mentioning is a new implementation of the remote reset functionality, with RBAC protection. This improves security and makes it easier to assign the fine-grained rights on who can remote reset which server. Setting up these rights will be easy for equipment groups because they already know how to use RBAC to restrict access to their FESA devices.

## Virtualisation

The BE/CO VirtualPC infrastructure continues to be consolidated and expanded. The BE/CO support team provides friendly user interfaces (using a centralized e-mail or the JIRA and the Atlassian tools) for the end-users to report issues or to request a new machine. In the same time the monitoring via DIAMON of the whole virtualisation infrastructure was improved.

At the end of 2014, 40 Terminal Servers and more than 400 Virtual Machines were deployed for the users of the accelerator infrastructure from BE, TE and EN. In addition, 5 clusters based on OpenStack technology were put in production for EN/ICE, TE/ABT, Cryo, EN/EL and GCS offering a much faster and solid service to these equipment groups. The clustering infrastructure provides better performance, and allows upgrades and maintenance of the machines without interrupting the service.

## Smooth Upgrades of the Accelerators Control system

After two years of LS1, the Smooth Upgrades WG was mandated by the LMC to restart the coordination of the technical stops for all accelerators. The purpose is to make sure all necessary upgrades can be done in a very short time slot of typically 24 hours. The Smooth Upgrades Working Group (SUWG) has one representative from each equipment groups, one OP representative per CCC island, one from each section of the CO group, and one each from EN/ICE, TE/MPE, and GS/ASE groups. Before a Technical Stop each SUWG member collects information about upgrades planned in their section or group and lists those plans in a standardized Excel sheet. This Excel sheet has columns corresponding to the criteria above, describing motivation, systems affected, risk mitigation and recovery, testing procedures, etc. The SUWG leader analyses all entries and identifies a list of upgrades that need to be discussed in the planning meeting. This list typically includes upgrades that are intrinsically risky, upgrades that potentially have a high impact on other systems if they fail, upgrades without a good recovery strategy, or upgrades that are not backward compatible and therefore required adaptations in other systems. Upgrades that are low-risk or limited in their impact need not be

discussed. A SUWG planning meeting takes place a week ahead of the TS. In this meeting, the controls experts from all areas discuss the list of upgrades mentioned above. Potential impact of an upgrade and side effects are analysed. Shaky recovery plans are improved. The correct order of carrying out upgrades is established. In some cases, the SUWG members will conclude that an upgrade is too risky and should not be carried out. The presence of several experts is often needed to clarify all aspects, and the input from OP is vital to decide which upgrades are important and which ones can or should be avoided or postponed. After the meeting the decisions about planned upgrades are published on the SUWG web site and announced in the FOM meeting preceding the TS. This forum gives the final go-ahead for the interventions.

## **The GIS Portal**

There was progress on the integration of electronics racks in the CERN Geographical Information System (GIS) Portal. This tool allows installation specialists to browse through racks in a graphical intuitive way. Efforts in 2014 focused on including more data about racks from CO and equipment groups, as well as extending the system to cover related areas such as electrical power distribution and Ethernet sockets and cabling.

## **Drivers**

Efforts in the Linux device driver area concentrated on the migration of legacy drivers to new platforms based on 64 bits, and on providing good diagnostics and monitoring for deployed solutions such as MIL1553. Insourcing of WorldFIP technology was another area of intense development, including the debugging of the existing software stack and initial developments for an insourced bus master. In the frame of the LHC Instability Trigger (LIST) project, new solutions for ensuring hard real-time behaviour in software were explored and implemented. The chosen technological solution involves soft CPU cores running bare-metal software, i.e. without an operating system, inside a Field Programmable Gate Array (FPGA).

## **Timing**

The timing team focused on the upgrade of General Machine Timing masters in different accelerators. The LHC system saw a major upgrade, migrating to a Linux-based VME Single Board Computer and going from a 3-crate to a single crate configuration. This simplifies the system, enables easier diagnostics and provides for a more robust solution.

Another area of intense development was the effort to replace the Distributed Table Manager (DTM) by an RDA-based solution. DTM is a legacy middleware which transmits timing information over UDP sockets. Efforts in 2014 focused on studying whether RDA can cope with the amount of typical clients of the system and help provide a solution for timing distribution over networks which is more robust than DTM.

## **Control Room Infrastructure**

1 blade enclosures, 12 Proliant Blades and 1 Proliant computer have been installed or upgraded in 2014. The disk capacity of our operational NFS servers has been doubled to cope with the new demands of Operation after LS1. And an automatic temperature control of the servers in the CCR was integrated into DIAMON allowing for automatic transmission of SMS and mail in case of temperature problem.

The 110 operator consoles in the CCC were replaced in December 2014 with new and more powerful PCs. This was done in close collaboration with the operation crews in order to minimize the impact on operation.

In parallel, the Mediacenters (PC that are controlling the 48 large displays on the walls of the CCC) and the VISTARS (PCs that are processing the fixed displays images) were replaced with new and faster computers.

25 digital 8 inputs encoders have been installed in ADE, SPS and LHC to offer a modern “video on demand” service for the BTV videos streams.

## **BE-OP Group**

### **Technical infrastructure**

The work load for the Technical Infrastructure operators continued to be very high throughout LS1 with between 200 and 300 calls per day concentrated during working hours. In order to cope with this work load, a second operator was seconded from the accelerators until the injectors started in the second part of the year. Many of the faults recorded during the year were linked to ongoing maintenance activities, but as the machines were not running, consequences were most often not very severe. The two most serious incidents took place in October 2014 with oil leaking into the nearby river Lion from a compensator on the Preveessin site and later the explosion of an 18kV breaker in building 212, one of the main electrical sub-stations on the Meyrin site. With the LS1 coming to an end, the volume of work for the Technical Infrastructure operator decreased but the potential impact of each fault increased again, threatening to stop physics.

## **BE-RF Group**

### **Linac14 Conference**

The LINAC14 Conference, locally organized by CERN staff members, has been a worldwide event with more than 480 registered participants from laboratories and scientific institutions all over the world; it was held at the Geneva International Conference Centre.

The RF Group, in particular, has been the chair of the Local Organizing Committee, of the Scientific Programme Committee and had the responsibility of organizing and managing the sponsoring activities and the Industrial Exhibition, which hosted 33 companies from the accelerator technology domain.

\*\*\*\*\*