



CERN-ACC-2015-0089

Andreas.herty@cern.ch

# Remote Qualification of HLS and WPS Systems in the LHC Tunnel

*H. Mainaud Durand, A. Herty, A. Marin, M. Rousseau, M. Sosin*  
CERN, Geneva, Switzerland

**Keywords:** LHC, Survey and alignment, HLS system, WPS system, remote qualification

## Abstract

The position of the inner triplets of the LHC is monitored using Hydrostatic Levelling System (HLS) and Wire Positioning System (WPS). A regulation of these systems is needed to guarantee the sensors' function. Such a regulation was done in-situ up to now, but the level of residual radiation at the level of the inner triplets will significantly increase with the next steps of LHC operation. Two systems have been designed to perform such a remote qualification: a filling/purging system for the HLS system and a wire displacer system for the WPS. In the paper, the requirements and the solutions proposed are described, with the emphasis on the conceptual design and the results obtained.

Presented at: International Workshop on Accelerator Alignment, IWAA2014, 13-17 October 2014,  
IHEP, Beijing, P.R. China

Geneva, Switzerland  
July, 2015

CERN-ACC-2015-0089  
04/08/2015



# REMOTE QUALIFICATION OF HLS AND WPS SYSTEMS IN THE LHC TUNNEL

H. Mainaud Durand, A. Herty, A. Marin, M. Rousseau, M. Sosin, CERN, Geneva, Switzerland

## Abstract

The position of the low beta quadrupoles of the Large Hadron Collider (LHC) is monitored by Hydrostatic Levelling Systems (HLS) and Wire Positioning Systems (WPS). These magnets are located on each side of the four experimental areas, where the level of residual radiation will significantly increase with the next steps of LHC operation. This will reduce the possibility of future access in these areas. The regular validation of monitoring systems is very important to guarantee the sensors' function and hence consistent data.

Concerning the HLS, the qualification is performed by varying the water level in the hydraulic network. The height difference observed on each sensor along the network must be the same. In the case of the WPS, the qualification is performed by displacing the wire at the fix points on both extremities. The difference between the readings of the sensors must be proportional to their longitudinal position.

Two systems have been designed to perform such a remote qualification: a filling/purging system for the HLS system and a wire displacer system for the WPS. In this paper, the requirements and the solution proposed are described, with the emphasis on the conceptual design and the results obtained.

## INTRODUCTION

More than 70 WPS sensors and 110 HLS sensors are installed in the LHC to monitor continuously and remotely the position of the low beta quadrupoles according to 5 degrees of freedom [1]. After four years of operation, it became evident that a remote qualification of the alignment was needed at regular intervals. It is mandatory to validate the alignment systems in order to guarantee the consistency of the data recorded by the sensors. Up to now, this task was done regularly by an operator, when access in the area was possible. Each validation was acknowledging the proper functioning of the alignment systems and thus the quality of data stored between two validations. The accesses in the low beta area will be less and less frequent and more and more short and difficult, taking into account the level of radiation, the cooling time needed after a run and the necessity to purge the helium contained in the low beta to guarantee a safe access. Two devices allowing the remote qualification of the HLS and WPS have been developed and validated. For both devices, the requirements, the concepts proposed, the strategy of development and validation will be presented. Then, the technical description and results obtained of the solution chosen will be discussed. A third device, allowing the remote detection of a broken wire will be also introduced.

## REMOTE DIAGNOSTIC DEVICE OF HLS SENSORS

### *The qualification of HLS sensors*

The standard method to qualify in-situ HLS sensors connected to the same hydraulic network consists in varying the level of water inside the network: the difference of height seen by each sensor must be identical for all sensors at the micrometre level (in stable environmental conditions). The height variation should be as wide as possible, in order to have the finest diagnostic.

In case an anomaly is discovered in this test, complementary inspection can be performed: network discontinuity, control of the remote electronics using capacitive references, qualification of the sensor on a metallic target to check the accuracy of measurement.

Up to now, the in-situ qualification of each hydraulic network was performed manually by adding or removing water. To carry out a remote qualification, solutions to automate the process of filling/purging had to be found.

### *Automated methods of filling/purging*

Two methods are proposed for an automated filling/purging of the HLS sensors:

- A solution based on two tanks: one for filling, the other for purging, linked to the main hydraulic network by a motorised valve, coupled with a manual valve to regulate the water flow. A pump ensures the link between the two tanks. A passive pipe could be added below the pump intake in the filling tank to avoid overflow. A filling of the hydraulic network located below the water surface would limit the waves.
- A solution based on one tank directly connected to the main hydraulic network, without valves, mounted on a feed screw shaft in order to allow its height variation; the height of the tank along the feed screw having a direct impact on the water level in the hydraulic network.



Figure 1: Conceptual drawing for remote filling/purging system

Each concept has its advantages and drawbacks: the second solution requires a rail rack motor combined with a

self-locking brake, a resolver and a consequent mechanical design. The first solution is more risky in case of a valve failure. Consequently, the feed screw based concept, has been chosen. A schematic of the concept is shown in Figure 1.

### Strategy of development and validation

The strategy described in Figure 2 has been followed.

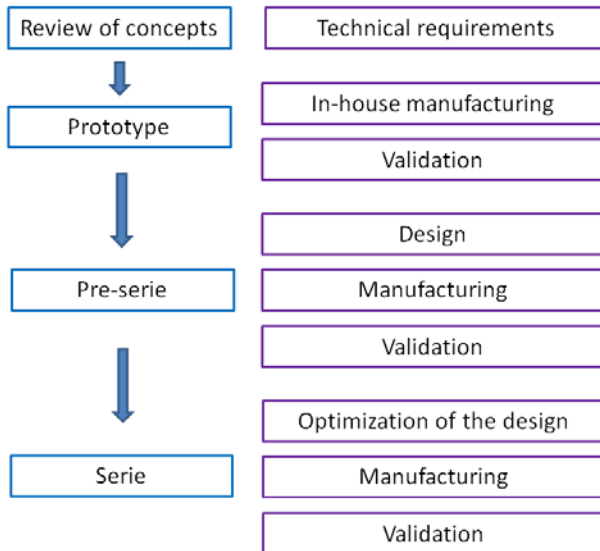

Figure 2: Strategy of development and validation

A first prototype has been prepared and tested on a dedicated test facility simulating the LHC installation on a prototype cryostat. The facility contains the longest low beta quadrupole, equipped with alignment sensors and supported by motorized jacks. The installation includes the same acquisition and control/command system than the one in the tunnel. This constitutes a very useful place to validate prototypes, pre-series and series, to control procedures and train operators on interventions before going in the tunnel where each intervention is timed due to the radioactive environment. Some first design parameters have been obtained on that facility: speed of displacement of the tank and its impact on waves in the hydraulic network. First integration hypotheses have been investigated: installation of the tank directly on the cryostat or independently from the cryostat on pillars or brackets.

Once the concept has been validated with the prototype, the project has been transferred to the CERN design office in order to prepare the detailed drawings of pre-series. The pre-series and series have been also validated on the test facility, taking into account the improvements seen at each step.

Such a sequential strategy has drawbacks: first, it takes time; second, if the quality of manufacturing concerning the pre-series is according to the specification, and the quality of manufacturing of the series not respecting the manufacturing tolerances, additional problems will be

discovered at the level of the series, requiring last minute interventions.

### Technical description of the filling-purging system:

The requirements to be fulfilled are the following:

- 18 hydraulic networks to be equipped
- 3 volumes of tanks chosen, according to the different volumes of hydraulic networks: 6 l, 12 l and 20 l, with the possibility to combine two tanks for the largest networks. The volumes are determined in such a way that the difference of height between the lowest and highest level of water covers the 5 mm range of HLS sensors. The same mechanical driving module for the three volumes has been chosen in order to decrease the cost of production and ease the intervention, maintenance and spare parts

The system developed consists of four parts:

- a support
- a linear motorised system
- a tank
- a control electronics

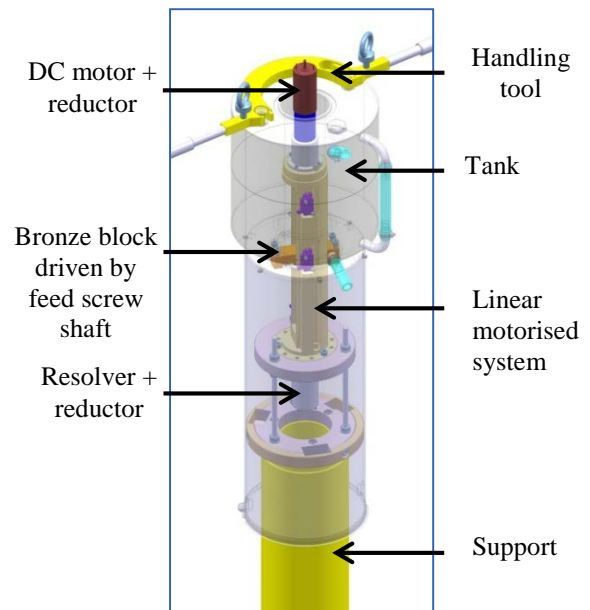

Figure 3: Filling-purging system

The support is either a pillar fixed on ground or a bracket fixed on walls. Its interface with the linear motorised system has been designed in such a way that the whole assembly can be dismantled very quickly without losing the position.

The linear motorised system allows tank motion with the maximum speed of 2 mm per second. It consists of a DC motor and brake, coupled with a planetary gearhead with a reduction factor of 111:1. This transmits the torque to feed the screw mechanism driving the tank. The pitch of screw is 2 mm, the stroke range is 200 mm. A high precision resolver is coupled with a planetary gear head with a reduction factor of 103:1. It is located at the bottom of the

assembly and provides absolute measurement of the tank position over the screw stroke range. The single resolver revolution covers 206 mm of possible stroke (gear ratio x screw pitch). The resolver, combined with the motor drive, allows an active local loop to control the displacement of the feed screw mechanism.

The command and acquisition electronics is an in-house development integrating the DC motor controller.

A dedicated tool to handle each tank has been developed.

### *Validation of the filling/purging system*

Prior to its cabling, each motorised unit had to undergo running-in periods of 50 cycles along its whole range in the mechanical workshop. Then, once all the components, such as motor, resolver, and switches have been added, cabled and adjusted, each linear motorized system was validated individually. It was plugged on a test-stand and current measurements were carried out under two test schemas in order to determine the parameters of each system. First, a displacement of the driving nut over the screw stroke was performed without the tank. As the friction was a parameter expressed by the current, the test was considered successful if the controller module did not show a current higher than 350 mA during the continuous displacement. Second, a fully loaded displacement with a tank containing 20 l of water was performed three times. This second test was successful if the current observed was not higher than 700 mA. At that stage, non-linear displacement, abnormal noise and sudden interruption of the displacement had also be detected to prevent from a later failure of components. The proper behaviour of the limit switches was also verified during the test.

### *Status*

All filling/purging devices have been validated. The series have been manufactured in two batches by different companies.

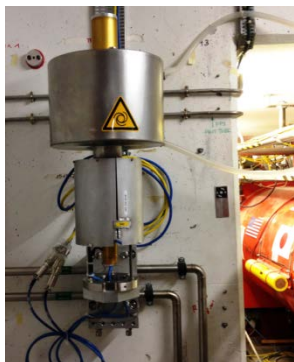

Figure 4: LHC installation of the remote qualification device of HLS sensors

In the first batch, the manufacturing tolerances had not been reached and some additional modifications had been

needed at CERN, which was not the case of the second batch.

## **REMOTE DIAGNOSTIC DEVICE OF WPS SENSORS**

### *The qualification of WPS sensors*

The standard method to qualify in-situ WPS sensors is to displace significantly by a few millimetres the stretched wire at its extremities, in both directions: vertically and horizontally. Knowing the displacement operated on the wire at the extremities, the offsets for each WPS can be computed theoretically, as they are proportional to the longitudinal position of WPS along the wire and then be compared to the observed displacement. The difference between theoretical and computed values should be below 1% of the displacement performed.

Up to now, these displacements were done manually, acting on the stretching devices. Different solutions to automatize the process of wire displacement have been considered.

### *Automated methods of wire displacement*

Two concepts to perform the remote qualification have been studied, prior to the design of a solution:

- A motorised displacement (along the vertical and horizontal axes) of the stretching devices, installing them for example on displacement tables.
- A displacement of the wire by a direct contact on it

The second solution has been chosen for its easier integration along the wire. Taking into account the level of radiation, radiation-hard displacement tables needed for the first concept are not available off-the-shelf. Such tables have a non-negligible height: all the pillars supporting the stretching devices should have been cut to integrate these tables. Third drawback of the first solution: the displacement of the stretching device is tricky in order to avoid that the 15 kg load oscillates during the displacement.

From the second concept proposal, two solutions of wire displacement system coming in contact with the wire have been proposed and studied:

- One system made of four thermo-electrical motors, each pushing a contact finger one after the other very slowly in order to displace the wire. The four contact fingers are implemented in a 90° position, allowing a dynamic displacement of the wire in four perpendicular directions as illustrated in Figure 5.

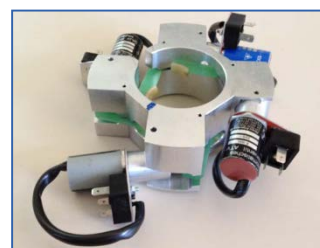

Figure 5: wire displacement system based on thermo-electrical motors

- Figure 6 shows a cam based system, displacing two jaws carrying along the wire in two vertical and horizontal extreme positions.

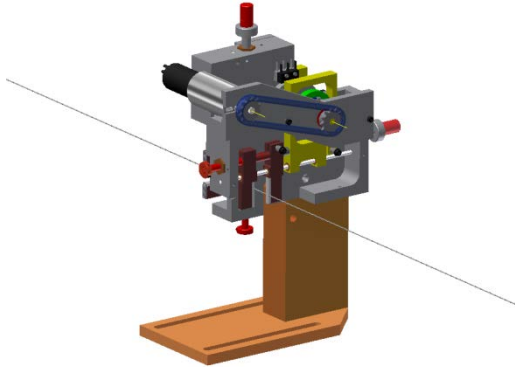

Figure 6: Wire displacement system based on a cam based system and jaws

The first solution has not been chosen, mainly because thermo-electrical motors have not been validated through irradiation tests. The same strategy of validation as for the HLS remote validation has been followed including a prototype, a pre-series and a series.

### *Technical description of the wire displacement system*

A single motor allows the rotation of the two axes at the same time, via a chain. A similar motor than for the HLS remote validation system has been used in order to ease the maintenance and the design of the control/command system. One full cycle takes approximately three minutes and consists of three sub-cycles: go to extremity position, go to opposite extremity position, return to parking position. The eccentricity of the cam can be adjusted to set the maximum displacement to be performed. The jaws are in PEEK, which is an insulating and radiation-hard material.

Both jaws are adjustable at the initial installation, in such a way that the wire can be displaced from its nominal position to an extreme position (maximum  $\pm 5$  mm in radial and vertical positions at the same time).

### *Validation of the wire displacement system*

The test facility has been used for the validation of the Wire Displacement Systems. The most important parameter to validate is the resistance of the stretched wire at the level of the contact point of the jaws. For that, a test set-up allowing repetitions of multiple standard cycles of measurements have been implemented. The objective was to count the number of cycles performed before the wire breaks. The system has been validated on supports located at different longitudinal position with respect to its extremities, corresponding to the positions of the tunnel: distances of 10 cm, 20 cm and 50 cm. One first conclusion

has been drawn: the number of cycles needed to corrupt the wire decreases when the system gets closer to the stretching devices, as the lateral force on the wire increases.

The jaws in PEEK did not succeed in the tests, with a too low number of cycles before a rupture of the wire: less than 10 cycles in average. The surface of the jaws is too abrasive for the wire. Other materials have been considered like polyacetal POM, but had the same problem of abrasion. Materials with a better capacity of polishing have been considered, as stainless steel and glass. Cycles obtained with jaws in stainless steel are far better, above 71 cycles, but not regular. Pyrex glass tubes mounted on aluminium pins have successfully undergone 3 iteration tests, with more than 231 up to 2103 full cycles before the wire broke, and have been chosen as material for the jaws.

Another possibility would have been to protect the stretched wire from the repetitive contacts of the jaws, using a plastic muff. The tests performed have shown a very high number of cycles: more than 231 as a minimum, up to 1440. Such a solution would have no effect on the catenary shape of the wire, as the shape is modelled using the last WPS sensors, the plastic muff being located above these sensors. But it has one drawback, considering that all the stretched wires are already installed in the LHC: such a modification would require the dismounting of the wire to insert the plastic muffs and hence could increase the risks of breaking the wire.

## **ANOTHER DIAGNOSTIC TOOL: THE WIRE BREAK SENSOR**

### *Introduction*

One drawback of the WPS sensor and its PEEK wire is that if the wire breaks, it can keep some rigidity: it will not collapse on the lower electrode of the sensor and can remain in a measuring position, being totally deformed. The case has been met twice and it has been decided to develop a remote detector for broken wire.

The wire is stretched by one fixed stretching device and one knife-pulley-stretching device holding the load of 15 kg. To prevent the weight from falling down on the floor from an important height if the wire breaks, a cage surrounding the weight has been installed to handle the weight as shown in Figure 7.

As a first solution, it was proposed to install a load sensor at the bottom of the cage: the sensor would have been activated when the weight falls down. But in given circumstances, it can happen that the weight does not touch the bottom of the cage once the wire is broken.

The requirements were the following:

- The wire break sensor must be independent from the position of the weight in the cage,
- No need to dismount the cage, lift up the weight or un-stretch the wire to install it,
- Very simple, robust and low cost solution.

## Description of the technical solution

The solution developed is compact, as shown on Figure 7. It is attached to the cable holding the cage. It is based on a switch that is triggered in case of additional load in the cage, so even if the load does not drop completely to the bottom part of the cage, the switch will be triggered. The installation is performed in less than 30 seconds, independently from the load and stretching devices, without any dismantling of other component, and more important: without any risk of breaking the stretched wire in place.



Figure 7: Wire break sensor

## IN HOUSE ACQUISITION AND COMMAND SYSTEM DEVELOPPED

An in-house solution named Survey Diagnostic Control System (SDCS) has been developed to be integrated easily on the existing data acquisition infrastructure, with the objective to be modular in order to ease the maintenance in case of failure [3]. The existing infrastructure consist of Survey Acquisition Systems (SAS) developed for the powering and acquisition of all the sensors installed in the LHC (WPS, HLS, DOMS, temperature probes). 1 SAS can drive 1 SDCS, knowing that each SDCS contains 2 driver cards for HLS filling/purging system, one driver card for two WPS wire displacement systems and wire break devices. A block diagram of the control electronics layout is shown in Figure 8. The SDCS contains also separated power supplies for logic circuits and output amplifiers powering.

For safety matters, several interlocks have been added:

- An external emergency stop button performing a general power-cut of the SDCS
- A software emergency stop based on control data cyclic redundancy check
- An emergency stop if the time constraint of the SAS Digital Output control lines is overshoot

All digital inputs/outputs and analog outputs of SDCS are opto-isolated from the SAS signal lines to avoid SDCS signals interferences on SAS measurements.

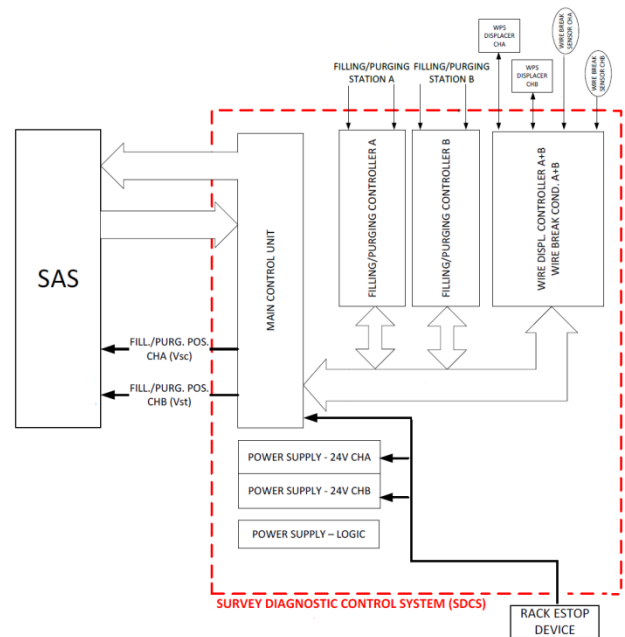

Figure 8: SDCS block diagram

## CONCLUSION

All the remote diagnostic systems have been installed in the LHC during the Long Shutdown 1 (LS1), and will allow remote qualification of the sensors during the three long years of run, starting beginning of 2015. Such an installation has to be considered as a first step towards High-Luminosity LHC (HL-LHC) [4]. In the frame of this project, in 2023, the four triplets located around ATLAS and CMS, as well as the major part of the components located in the Long Straight Sections, will be changed, in order to increase the luminosity of the LHC. Considering the level of radiation at that time, the remote diagnostic systems will be more than mandatory, and the experience gained with the systems installed during LS1 and operated the following years will be very useful.

## ACKNOWLEDGMENT

The authors would like to acknowledge Antonin Bonal, Michael Udzik, Bruno Perret and Jacek Sandomierski for their participation in the manufacturing and validation of the remote qualification systems.

## REFERENCES

- [1] H. Mainaud Durand et al., "Permanent monitoring of the LHC low beta triplets: latest results and perspectives", IWAA 2010, DESY, Germany (2010)
- [2] M. Sosin, "User Manual for LHCGIHL\_0094 (linear motorized system) test using delivered test equipment", edms n°1417319, CERN, 2014
- [3] M. Sosin, "Survey diagnostic control system (SDCS): electronic controller – programmer description", edms n°1417315, CERN, 2014
- [4] HL-LHC website:  
<http://hilumilhc.web.cern.ch/HiLumiLHC/index.htm>

