

NPA/Int 69-17
16.9.1969

THE OBSERVATION SCREEN AND TV INSTALLATION
OF THE EXTERNAL PROTON BEAM MONITORING SYSTEM

R. Grüb and J. Høyer

CONTENTS

	<u>Page</u>
1. INTRODUCTION	1
2. SCREENS	1
2.1 Sensitive material	1
2.2 Fixed screens	2
2.3 Flipping screens	2
3. TV SYSTEM	3
3.1 Cameras	3
3.1.1 The monoblock camera	3
3.1.2 The distributed camera	4
3.1.3 The biblock camera	5
3.1.4 Conclusions and recommendations	6
3.2 Cables	6
3.3 Monitors	7
3.3.1 Outdated monitors	7
3.3.2 State of art monitors	7
3.4 Shielding and supports	8
4. OPTICAL LENSES AND MIRRORS	9
5. ILLUMINATION	10
6. ACKNOWLEDGEMENTS	11
REFERENCES	12

1. INTRODUCTION

Pulsed deflectors and quadrupole lenses are used to guide a fast ejected proton beam from the exit window in the PS ring and to focus it on to a target in the neutrino tunnel¹⁾. For initial setting-up, the proton beam is observed by fluorescent screens viewed by TV. For final beam adjustments the following beam monitoring devices are useful:

- beam current transformers
- electrostatic pick-up stations
- target monitor (charge monitor)
- beam profile and intensity monitor (activated foils, etc.)
- fluorescent screens viewed by TV
- secondary particle flux monitors .

This note describes the installation of the fluorescent screens, TV cameras, monitors, and optical lenses for the neutrino experiments, the p_5 experiment and k_{11} experiment. The most urgent improvements required for the planned Gargamelle beams are also considered, taking into account the operation experience gained since the first installation was made in 1962. The fluorescent screens and the cameras are installed at selected positions along the beam line, both in the PS ring and in the neutrino tunnel. Care has been taken to reduce or to avoid radiation damage and disturbance by pulsed magnetic fields.

The display monitors are placed in the beam control station, and give an immediate and concise indication of the beam position, its size and shape, and any instabilities of the ejected proton beam.

2. SCREENS

2.1 Radiation-sensitive material

Our early experience with, and more recent tests carried out on the external proton beam transport system showed that zinc-cadmium sulphide is the most suitable fluorescent material for the TV screens. The processing of ZnS is very easy, and the ratio of photons/protons is rather high. At 20 GeV/c and 10^{10} protons/cm² a light spot is almost visible. Other possible fluorescent materials such as quartz, lithium glass, and sapphire are less sensitive than ZnS and are more expensive⁴⁾.

However, beam observation with zinc-cadmium sulphide has some disadvantages. After exposure to about 10^{17} protons/cm², the screen becomes inactive. This phenomenon becomes especially apparent on the target screen, where the full proton beam hits the screen within a diameter of two millimetres. To reduce this "burn out", a window is cut out of each screen, and the major part of the proton beam passes without touching any material. Scattering therefore as well is reduced.

2.2 Fixed screens

The fluorescent material must be hit by the high-energy particles in order to light up. In the external proton beam transport system, the proton beam is guided in a glass vacuum pipe and intercepts zinc-cadmium sulphide screens introduced into the glass pipe at selected positions.

The mechanical construction of these screens is very simple (see Fig. 9). An aluminium foil of 0.02 mm thickness is glued with Eastman 910 on to a thin aluminium tube, and then covered with a layer of ZnS powder (crystal-clear spray coating is used as binder). The final thickness of the sensitive layer is of the order of 0.5 mm. A network of pencil lines with a spacing of 5 mm permits spatial location of the light spot.

The main advantage of this type of screen is the small space required. In between beam transport elements, only an unobstructed region equal to the diameter of the vacuum pipe is needed.

This type of fluorescent screen is introduced into the glass vacuum pipe. To avoid light reflection, a flat glass window is fitted on the glass tube (see Fig. 9).

The glass pipe fits well in the magnet aperture, and therefore additional adjustment for the screen is not required. The achieved precision is ± 0.5 mm.

2.3 Flipping screens

Instabilities of the ejected proton beam vary the beam size, its position, and the quantity of the ejected protons at the entrance of the pulsed beam transport system. Under such unfavourable circumstances, beam observation with TV requires a fluorescent screen which covers the whole aperture. In order to avoid scattering and to reduce as much as possible the "burn out" effect of a fixed screen without beam window, a

flipping-screen mechanism was developed⁶). This mechanism consists of a remotely controlled movable screen without window, and a stationary screen with a relatively large window so that the proton beam grazes the ZnS screen only when it is displaced or blown up (see Fig. 15).

Both screens are fixed in a special vacuum box and are easily replaceable (see Fig. 8). Adjustment with respect to the beam centre must be carried out; the attained precision is of the order of ± 0.2 mm.

A series of ten units are being manufactured for the k_{11} and the neutrino experiments. We have also included the same type of flipping-screen mechanism, but of slightly different dimension, in the proposal for the external proton beam Mirabelle at IHEP, Serpukhov⁷).

3. TV SYSTEM

3.1 Cameras

The TV cameras used for the installation are essentially of three different makes and styles, each presenting their advantages and disadvantages. They represent the current designs over the past years, and are very similar with respect to basic circuitry and the way of functioning. Figure 2 shows a block diagram of a TV camera. Also, for practical purposes, the output composite video signals of all the cameras must conform to the CCIR standards so that any camera connected to any monitor will give an acceptable picture.

With respect to reliability, performance, and ease of installation and maintenance, there are however some considerable differences.

The three basic types are:

- i) the mono-block camera
- ii) the distributed camera
- iii) the bi-block camera.

3.1.1 The mono-block camera

In the installation this is represented by the ACEC camera, types 6004 and 6014. The mono-block camera is the camera to be preferred, because it is easy to install and to replace, since it contains everything necessary for generating the composite video signal in a single box.

It requires a connection to the mains and a coaxial cable to transmit the composite video signal to the monitor (in the beam control station).

When making the last fine adjustment to the camera position just before a run, a small portable TV monitor is used, connected by a short coaxial cable directly to the camera video output. In this way the correct view is quickly obtained.

Four of these ACEC cameras were installed in our first beam in 1962 and their performance and reliability has proved sufficient, although some refinement of certain details would be desirable. The construction is rugged and simple. Whilst they contain only tubes and a few semiconductor diodes, these cameras, actually in service as TV 3 and TV 4 in the accelerator ring, have performed satisfactorily in this radioactive zone.

The major disadvantage of these cameras is that they have not been available on the market for a long time, nor have accessories been available for them; and due to their age the quality of the pictures is inferior to that obtained with the transistorized cameras now on the market which, however, are of limited use since they are not radiation-resistant.

3.1.2 The distributed camera

Another type of camera used in the installation is the EMI type BC 601 A ⁴⁾. It consists of a number of large and small boxes containing various parts of the camera circuitry. One aim of this arrangement is to keep the camera head assembly small; this assembly includes only the picture tube and the most essential parts for converting the picture into the low-level video signal. This is the only part that has to be located in the radioactive area close to the object to be viewed. There is hardly any amplification, and consequently the signal to be transmitted via a cable to the other part of the camera is very weak, about 50 mV. Experience has shown that the advantage of having only a very small part of the camera in the radioactive zone where the view is taken is of little or no importance, whilst the weakness of the signal makes the system very sensitive to electric noise, which generally results in poor-quality pictures. The other camera parts are a preamplifier and a synchronization

and power supply unit. The interconnecting cables are special and rather expensive 25-core cables, with special connectors that have proved a major cause of trouble, since if one of the 100 (4 × 25) connection points is slightly defective this may make the picture unusable.

In order to reduce the number of camera boxes, a switch-over facility was included in the installation, enabling two out of four camera signals at a time to be amplified and displayed on two monitors. Thus for four cameras there are only two synchronization and power units and two pre-amplifier units. The switching and preamplifier unit contains two pre-amplifiers and two switches. The heating of the tubes is arranged so that all tubes are constantly heated at either position of the switches. Figure 3 shows the schematic of the switching arrangement. To summarize, it may be said that although this camera has a quite complicated circuitry, there is no noticeable improvement in its performance as a result of this, since its construction is so inadequate on major points.

The main argument which led to the purchase of this equipment in 1965 (contrary to the advice of one of the authors of this report) was that, apart from its relatively low price, it was desirable to have the same equipment as was being purchased for the MPS in greater quantity. The four EMI cameras are actually in service as TV 5, 6, 7, and 8.

3.1.3 The bi-block camera

The Thomson camera THV 160B represents a solution that is a compromise between the two solutions mentioned above. It consists of a part for generating the video signal, and a synchronization and sweep generator part. The picture-tube part (actually installed as TV 2 in the PS ring) contains only nuvistors and other components that are radiation-resistant.

The other part contains semiconductors, which enables it to be small, and since it is located outside the radiation area the over-all camera system is not affected by radiation.

One such camera was installed in 1966 and has worked very reliably and satisfactorily but involved some inconvenience with respect to installation and adjustment. There is no video outlet to enable the quick fine adjustment of the camera position by means of a portable monitor, and a special multicore cable is required between the observation point and the display.

3.1.4 Conclusions and recommendations for the planned Gargamelle beams

Since all cameras used in the external proton beam transport system are looking at fixed points, i.e. the fluorescent screens, they do not require any readjustments of focusing, sensitivity, etc., whilst in service, as long as they maintain their characteristics once they are adjusted.

Cameras of reasonable quality, now available on the market, fulfil this requirement. Consequently, the unnecessary complications of remote adjustment mechanisms for focusing, sensitivity, etc., should be avoided.

Clearly, a mono-block camera would be preferable, but it is quite some time since radiation-resistant cameras of this type have been available. Fortunately this is no longer the case, as the Thomson camera THV 1200N, now on the market for some time, is radiation-resistant to a considerable degree. It does, however, contain several semiconductor devices, and its life in radioactive areas is therefore limited. In view of this, contact has been made with a company that is willing to develop and construct mono-block cameras that do not contain any semiconductors. Work has started, and it is hoped that this year a great improvement on our system can be achieved and included in the π beams m_{10} and g_4 and the new neutrino beam installation for the initial experiments with Gargamelle in 1970, provided the necessary money is available.

3.2 Cables

All the TV cables either pass through or end at some point in the neutrino tunnel. In this tunnel, however, the installation is changed periodically; consequently, because of the different kinds of work carried out there very frequently, the multicore connectors and cables are often damaged or are disturbed sufficiently to cause serious failure of a TV chain. It is therefore preferable to have only a coaxial cable as the connection between camera and monitor instead of a multicore cable. Of course, a coaxial cable and connector can also be damaged, but it is relatively easy to replace the connector, and damage to the cable usually causes impedance mismatch, which so far has had no noticeable influence on picture quality.

3.3 Monitors

For the TV monitors, as was the case for the cameras, the electronic circuitry is very similar for the different makes and models, and it is mainly with respect to reliability, performance, ease of operation and maintainance that they present some interesting differences.

The cameras were required to be radiation-resistant, but for the monitors no such special requirement exists. Consequently, the market offers a greater choice of monitors than of cameras, adequate for the purpose. The number of different makes of monitors represented in the installation reflects this situation.

3.3.1 Outdated monitors

The monitors ACEC type 6052, EMI type TPM 6/14 A, and the Fernseh GMBH type TV 601, are all, on certain points, more or less inferior to the monitors now available on the market; consequently they must be regarded as outdated. The ACEC monitors have given satisfactory performance since 1962 and, considering their age, they are still doing so. They were the very first in use here. However, their synchronization is not very efficient. The EMI monitors were brought into service quite some time later, in 1966, but have shown insufficient reliability and picture quality. Thus they compare rather unfavourably with the ACEC monitors. The Fernseh monitor should perhaps not really be considered as outdated, since it gives quite a reasonable picture. It is, however, rather inconvenient to synchronize.

3.3.2 State of art monitors

The Thomson monitors, type THV 217 B and type THV 220, have given satisfactory performance for years without needing any repair. It may, however, be noted that the type THV 220 needs some free space around it to ensure free air circulation, otherwise it will overheat and stop functioning. These monitors are, however, relatively expensive, and one inconvenience that they share with the other monitors (except the EMI) is that some important controls are placed at the rear of the cabinet. When slight readjustments are needed -- for instance, following a switching over from one camera to another one that is no longer adjusted exactly as the first one -- the rear panel screwdriver adjustments are very inconvenient.

Fortunately, a monitor is available on the market which has none of the aforementioned disadvantages and which, in addition, is very economical and compact (portable). It is the Sony PVJ-2020E (5" picture) or CVM-306 UMP (9" picture). Experience has shown that the small picture-size is just right for this application. A 5" Sony monitor has been used since 1967 with great success for initial on-the-spot adjustments of the cameras, for various experimental set-ups, and as replacement in case of failure. Its only disadvantage seems to be that it may be difficult to repair it because of its small size and somewhat tightly packed circuitry.

An inexpensive and yet considerable improvement of the installation might be obtained by replacing the outdated units with monitors of this type. A gradual adopting of the new type is considered in connection with the rearrangement of the installation for the planned Gargamelle beams.

3.4 Shielding and supports

Stray magnetic field created by the PS ring magnets and the pulsed beam transport magnets influence the behaviour of the TV cameras. A magnetic field of 10^{-3} Tesla makes the TV picture unusable. Even if this limiting value is reached in only some cases, magnetic shielding for all cameras is indispensable.

The nuclear radiation damage causes deterioration of the picture quality over a long period (see Section 3.1.1). Radiation shielding is possible but uneconomic. Consequently, cameras and optical lenses should be made of radiation-resistant material.

For TV 2 and TV 3 we use the ACEC camera-housing of Mu-metal; TV 4 is shielded in a box made of 3 mm thick soft-steel plates. All boxes are attached to the common rigid I-profile support for the pulsed beam transport magnets.

In the neutrino tunnel the cameras were originally mounted on vertical supports above the vacuum chamber and magnets. In this region, however, changes in beam layout and magnet position are made from time to time, as required for different experimental conditions (change from neutrino experiment to k_{11} or p_5 experiment, etc.). The vertical supports hindered the displacement and alignment of the magnets. We therefore

designed new supports, which are fixed to the tunnel wall. Although these supports are very rigid they can be very quickly displaced when required for modified beam conditions.

All cameras are aligned at the same height as the beam but at a right-angle to the beam path. Facilities are provided for the adjustment of position and orientation in all directions.

The housings for the cameras in the neutrino tunnel are made of 8 mm thick soft-steel plates, and provide magnetic shielding as well as protection against mechanical damage.

The Mu-metal boxes for TV 2 and TV 3, and the steel boxes for TV 4-8, provide sufficient protection against the pulsed magnetic fields present. Space is foreseen for additional shielding blocks around the cameras if this is needed for further protection against radiation or magnetic fields.

4. OPTICAL LENSES AND MIRRORS

The first lenses used for the TV cameras were made in our local workshop. The objectives consist of one or two untreated bi-convex lenses of 42 mm diameter fixed in a brass tube. The picture obtained with this kind of lenses was not sufficiently clear because of the additional electrical disturbances due to long cables, magnetic fields, etc. Home-made lenses were more expensive than the industrial lenses now available (with the exception of the F:8/600 mm lens for TV 8). We therefore equipped all cameras with industrial lenses. The focal distance is given by the dimensions of the sensitive vidicon layer, the dimensions of the fluorescent screen, and the distance between vidicon and screen (see Fig. 11). The insufficient depth of focus is visible, however, correction is impossible without extra cost.

Radiation causes browning of the lenses, and with a dose of 10^5 rad the lenses become almost opaque (this depends largely on the type of glass used) so that regeneration becomes necessary. With the home-made lenses this regeneration procedure was very simple. A heat treatment over 4 hours at 350°C cleaned the lenses.

With complicated multi-lens objectives, mostly with glued lenses and grease inside, such a treatment would have catastrophic consequences.

The alternative procedure is irradiation by UV rays. Using an Osram GU 53 lamp, the brown colour disappears in about 60 hours. Good results have been obtained with this method; the effect coloured-colourless is easily reversible.

As mentioned above, the focal length is adapted specially to each camera and screen. Five objectives are 135 mm/F = 2.8 lenses (TV 3, 4, 5, 6, and 7); one is a 75 mm/F = 2.8 lens (TV 2); and one, TV 8, with a distance vidicon - fluorescent screen of 7100 mm, has a focal length of 600 mm at F = 8.0.

The distance between vidicon and screen for TV 2 - TV 7 is about 1100 mm. The angle of view for TV 2 is 8°; for TV 3 - TV 7, 5°; and for the 600 mm telephoto lens, 1°.

Lens errors, like chromatic error, spherical error, astigmatism, etc., can be neglected. Line width and electronic deviation from ideal conditions have more influence on the quality of the picture.

The distance between camera TV 8 and target is 7100 mm. In order to obtain this long distance in the neutrino tunnel, a mirror deflects the beam along the tunnel. This optical beam path can be interrupted by a flipping mirror. The flipping mirror looks -- via another mirror to equalize different screen-camera distance -- on to a fluorescent screen in front of Q 9 (see Fig. 7). All are optical mirrors so as to avoid brightness losses due to coloured glass.

5. ILLUMINATION

The fluorescent screens require a background illumination to adjust the camera and the monitor, and to equalize brightness differences between the lightspot and the left part of the screen. For the fixed screens, two electric lamps of 100 W/220 V are used. Regulated by a variac, the maximum voltage never exceeds 80% of the nominal value. This voltage-limiting increases the lifetime of the lamps (see Fig. 17).

Low voltage is used for the lighting of the flipping screens. Two 24 V 7 W lamps are incorporated in the box. The remote illumination control panel is located in the beam control station near the TV monitors.

6. ACKNOWLEDGEMENTS

Thanks are due to Messrs. J. Del Rey and J. Michaud for the construction of many mechanical parts, and to Messrs. G. Aquistapace and H. Pflumm for assembling and testing the electronic circuits and for participating in the continuous maintenance of the system over the years.

We are grateful to our group leader, B. Langeseth for much valuable advice and to Dr. C.A. Ramm for useful discussions and information.

REFERENCES

- 1) B. Langeseth, A pulsed beam transport system for the external proton beam of the CERN proton synchrotron, CERN 64-35 (1964).
- 2) B. Langeseth, Specification for closed circuit television system for nuclear physics applications, CERN internal note I-3914/NPA.
- 3) B. Langeseth, J.M. Maugain and F. Völker, Project study and technical proposal for the external proton beam channel for the CERN-Serpukhov collaboration, CERN internal note NPA/INT 68.6, 7.3.1968.
- 4) Camera and monitor manuals from ACEC, Thomson Teleindustries, and EMI.
- 5) D.A.G. Neet, Beam profile monitors for fast and slow extracted proton beams, CERN internal note ISR-CO/69-4, March 1969.
- 6) J. Hirsbrunner, Ecran mobile d'observation du faisceau, CERN internal note NPA/PBT 69-3.
- 7) AEG Lichttechnische Mitteilungen.

Figure captions

- Fig. 1 : Experimental area layout for neutrino experiment.
- Fig. 2 : Block diagram of a TV camera.
- Fig. 3 : Switching arrangement TV 5/7 and 6/8.
- Fig. 4 : Schematic of camera-monitor installation.
- Fig. 5 : View of control and display assembly.
- Fig. 6 : Influence of magnetic field on picture quality.
- Fig. 7 : Camera arrangement in target region for k_{11} experiment.
- Fig. 8 : Camera assembly and flipping screen.
- Fig. 9 : Fixed screen in glass pipe.
- Fig. 10 : Camera TV 8 with telephoto lens 600 mm.
- Fig. 11 : Optical diagram.
- Fig. 12 : "Home-made" lens.
- Fig. 13 : Flipping screen mechanism.
- Fig. 14 : Window dimensions for fixed screen.
- Fig. 15 : Window dimensions for flipping screen.
- Fig. 16 : Flipping mechanism on the magnetic horn.
- Fig. 17 : Lifetime curve for illumination bulbs.
- Fig. 18 : Radiographs of some screens.

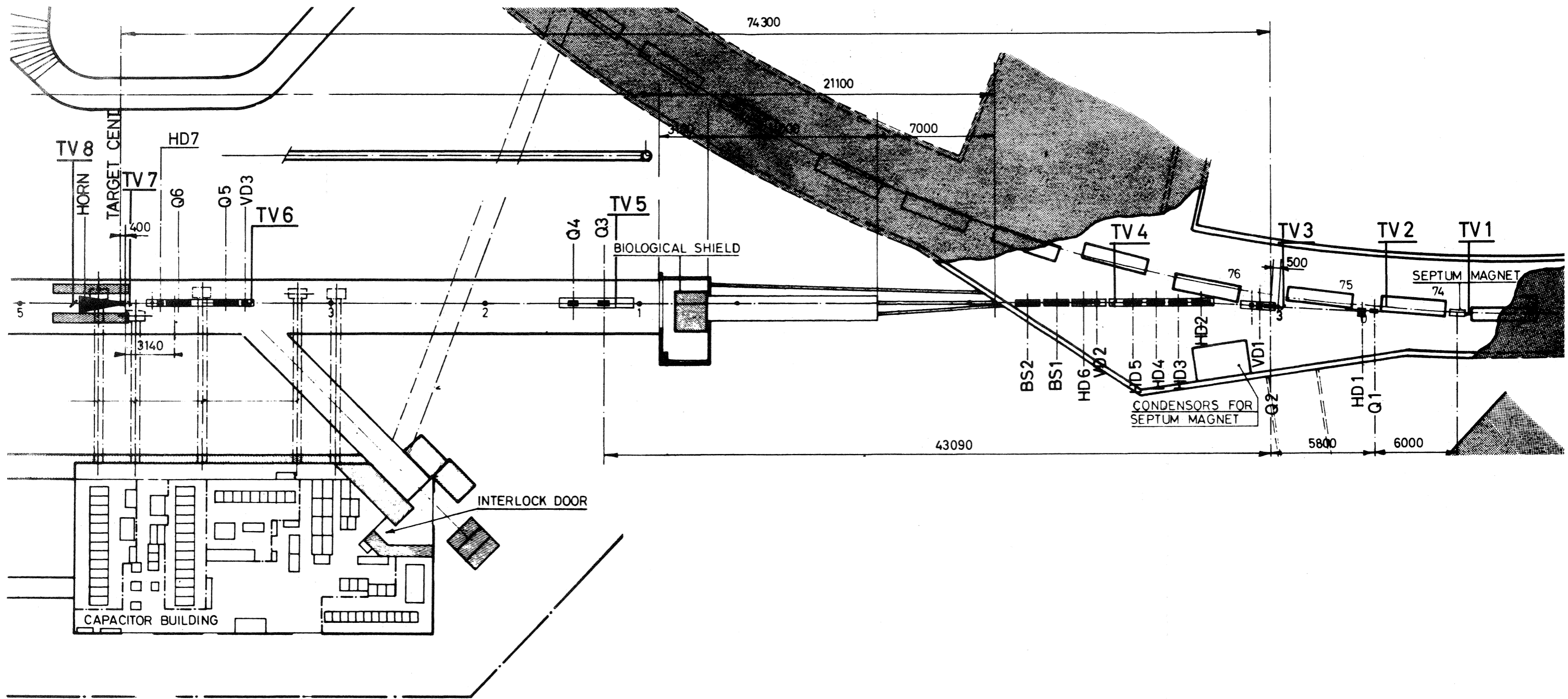

EXPERIMENTAL AREA LAYOUT FOR NEUTRINO EXPERIMENT

FIG.1

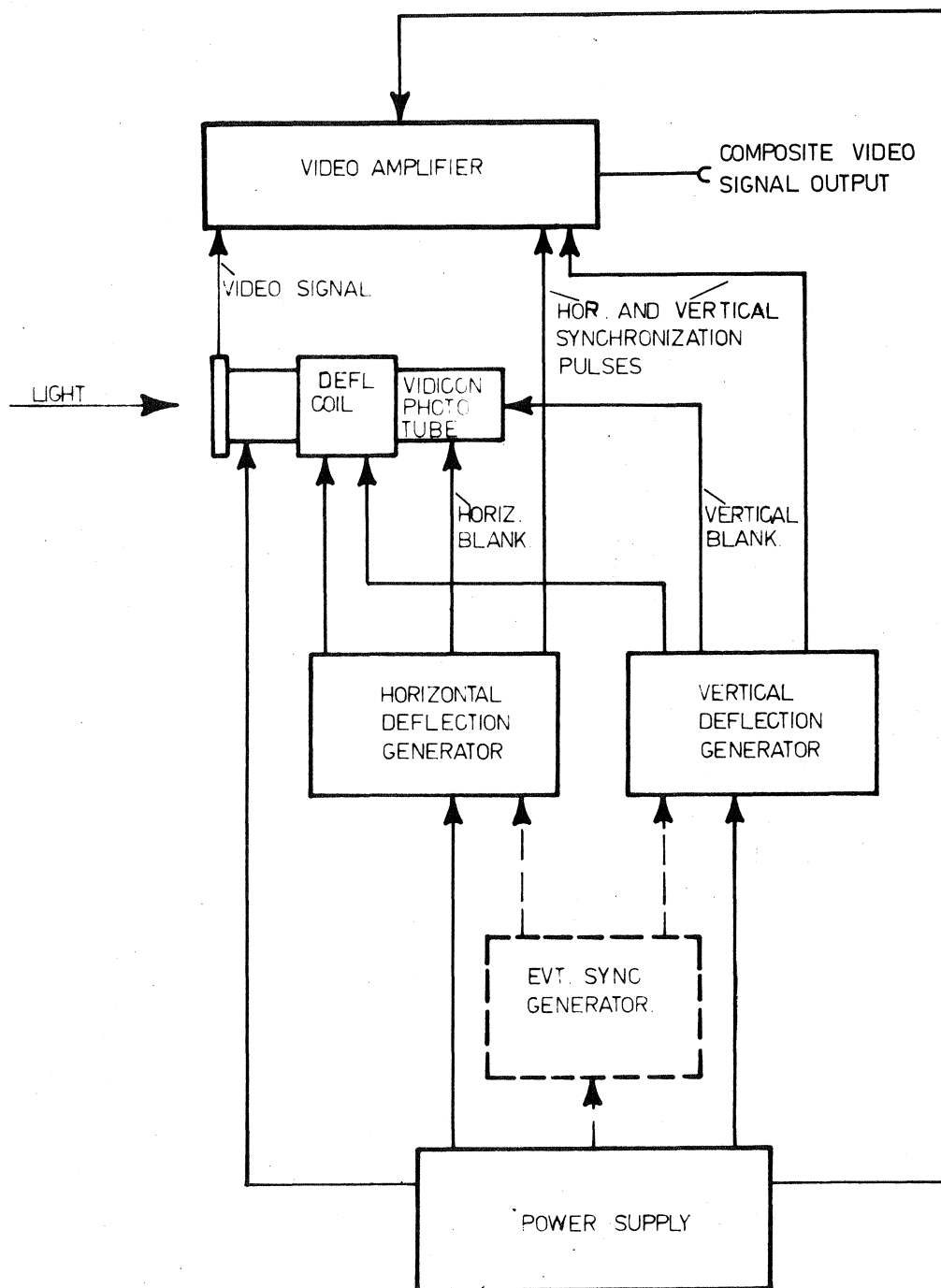

BLOCK DIAGRAM OF A TV CAMERA

FIG. 2

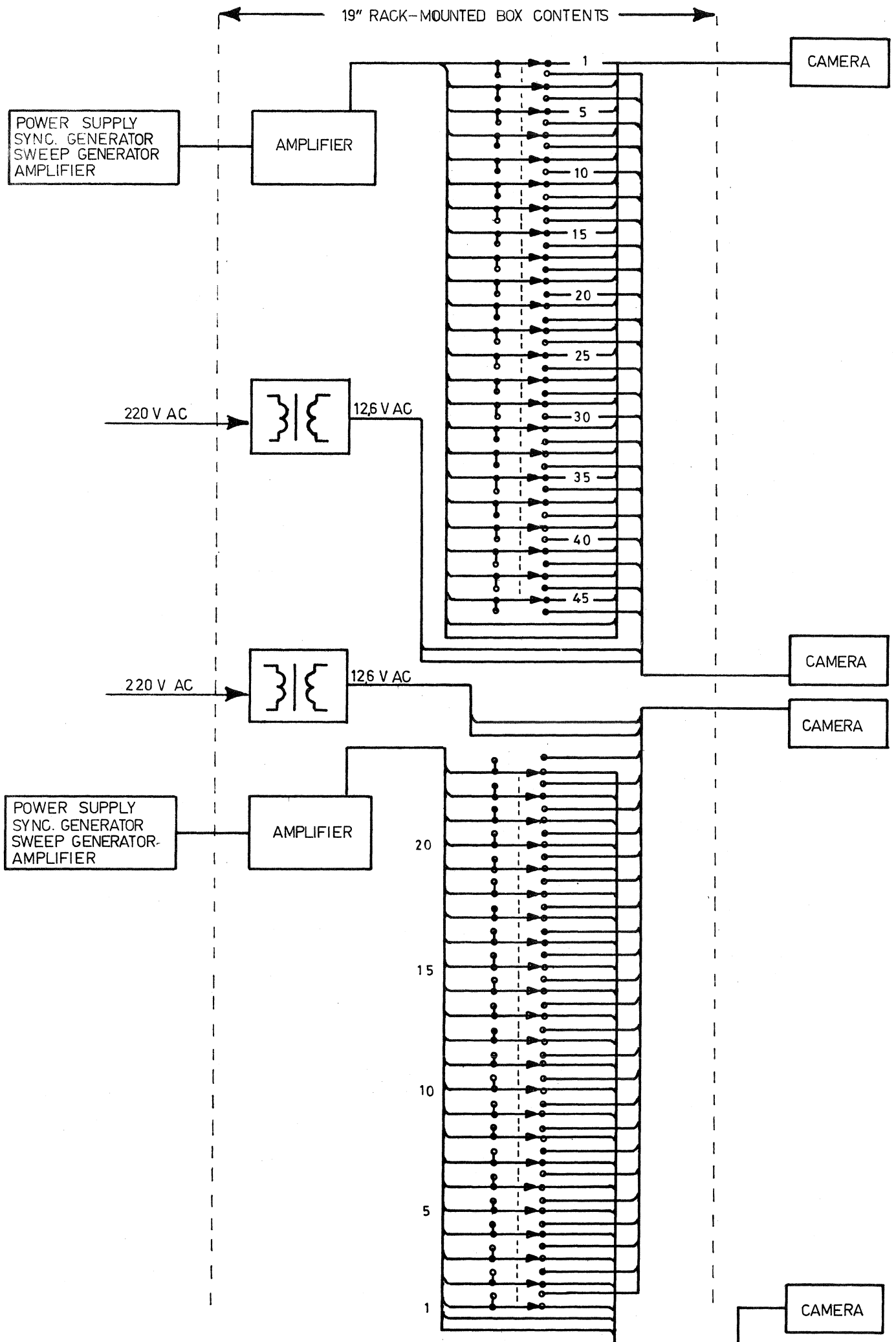

SWITCHING ARRANGEMENT TV 5/7 AND TV 6/8

FIG.3

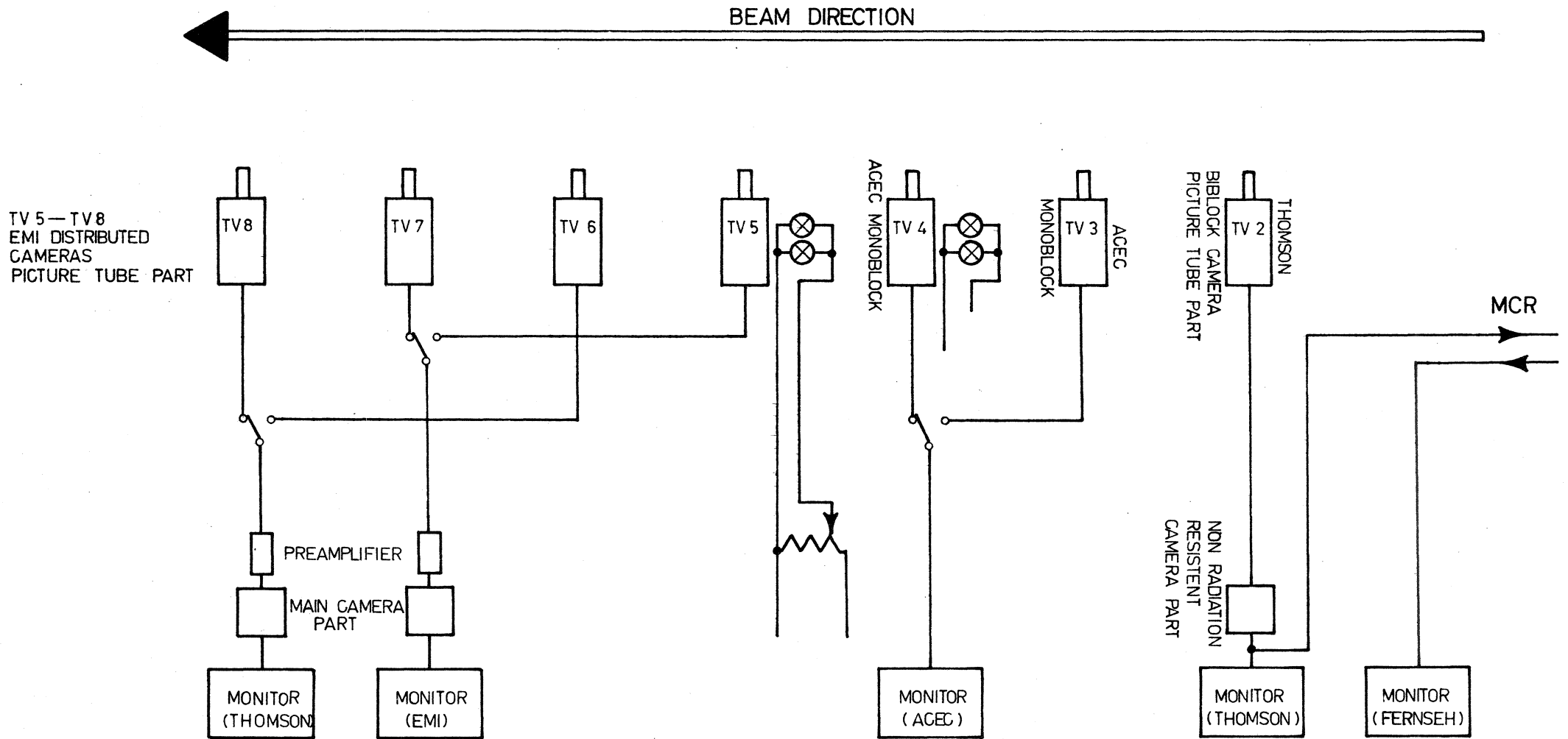

SCHEMATIC OF CAMERA-MONITOR INSTALLATION

FIG. 4

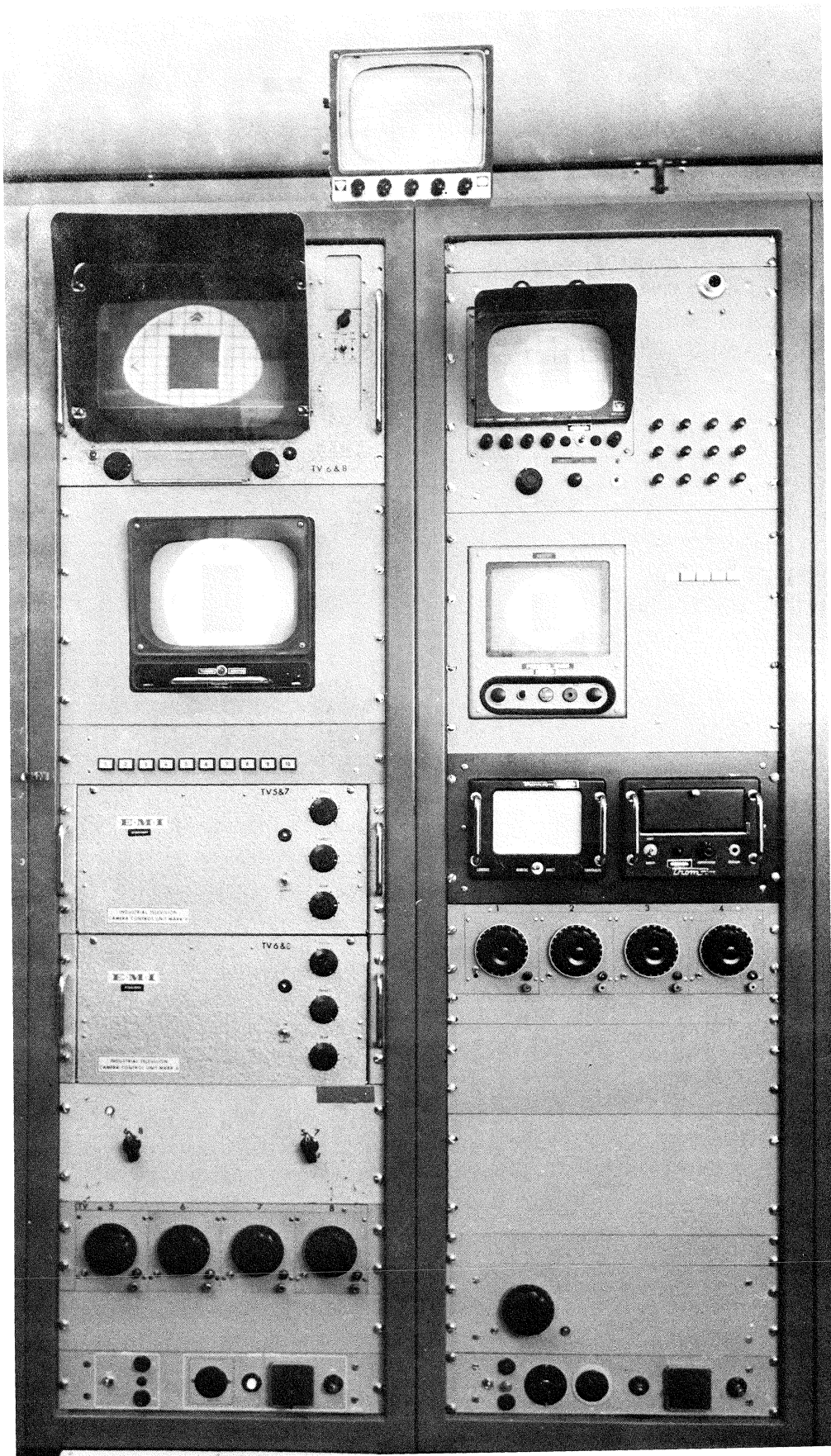

VIEW OF CONTROL AND DISPLAY
ASSEMBLY

FIG.5

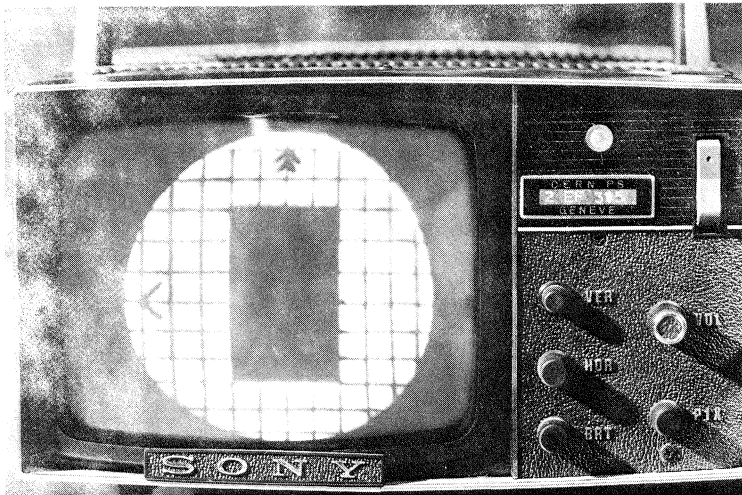

CAMERA: THOMSON THV 1000
MONITOR: SONY PVJ 2020E

WITHOUT MAGNETIC FIELD

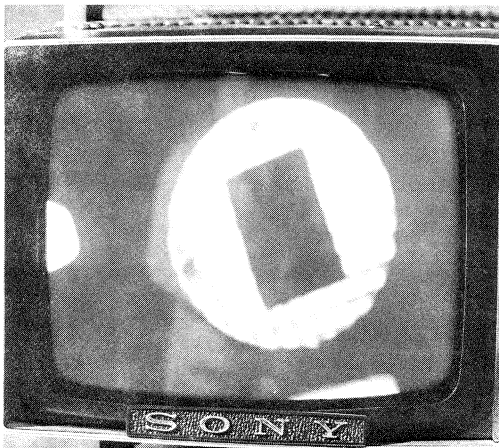

LONGITUDINAL FIELD OF 13 G



LONGITUDINAL FIELD OF 47 G



HORIZONTAL TRANSVERSE
FIELD OF 20 G



VERTICAL TRANSVERSE
FIELD OF 20 G

INFLUENCE OF MAGNETIC FIELD ON PICTURE QUALITY

FIG.6

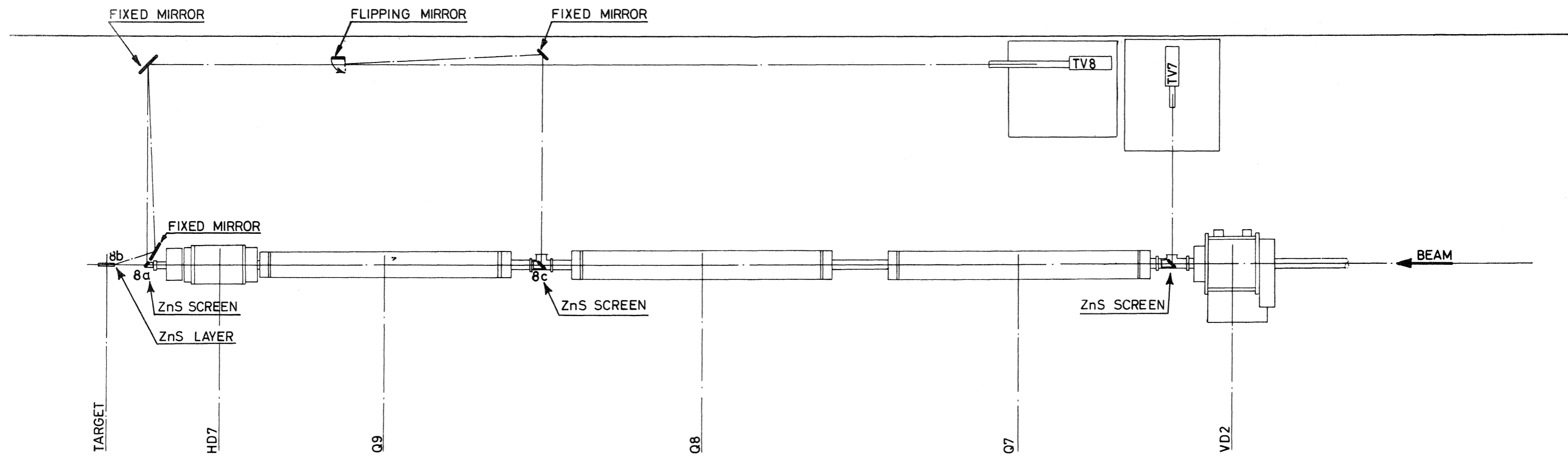

CAMERA ARRANGEMENT IN TARGET REGION FOR K11 EXPERIMENT
 FIG. 7

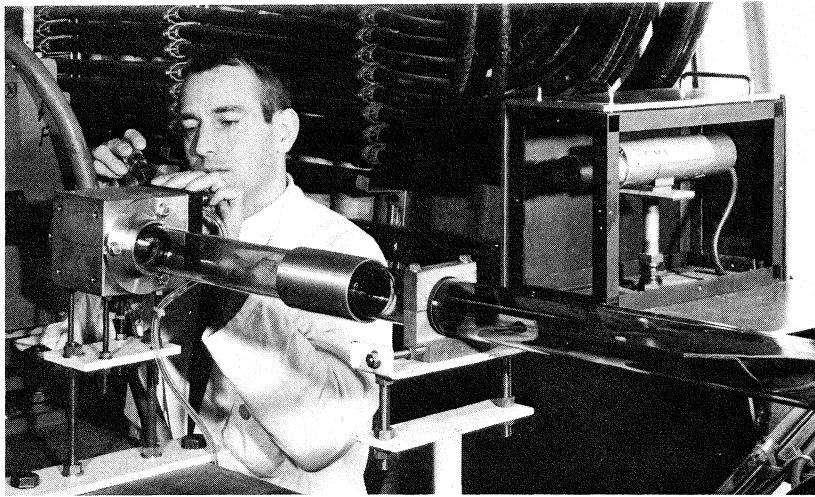

CAMERA ASSEMBLY AND FLIPPING SCREEN

FIG. 8

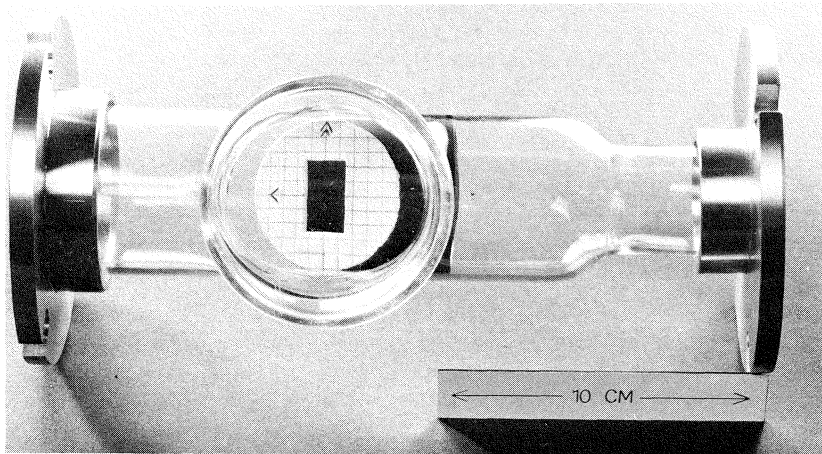

FIXED SCREEN IN GLASS PIPE

FIG. 9

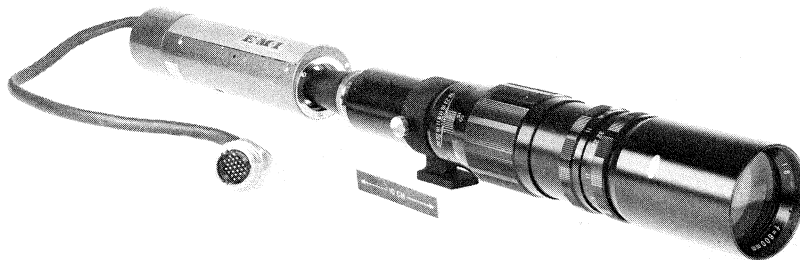

CAMERA TV8 WITH TELEPHOTO LENS 600mm

FIG.10

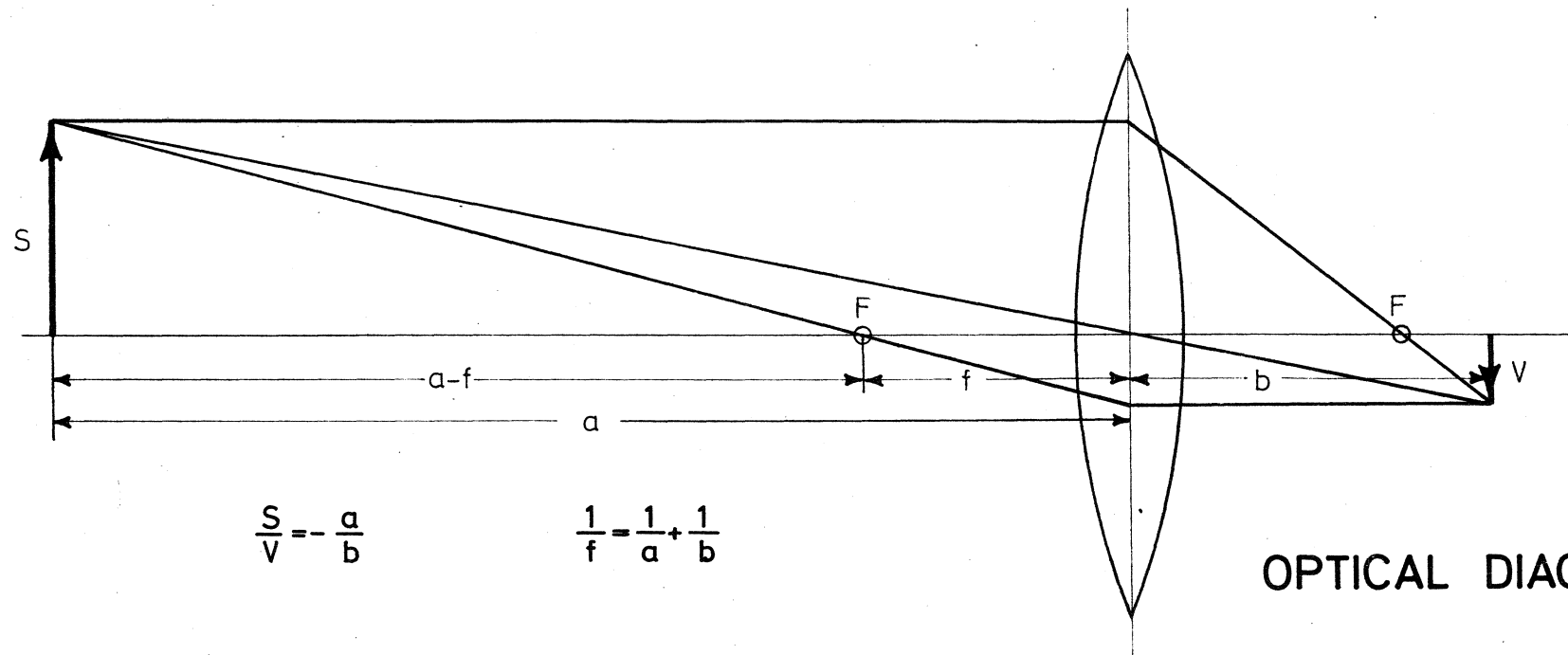
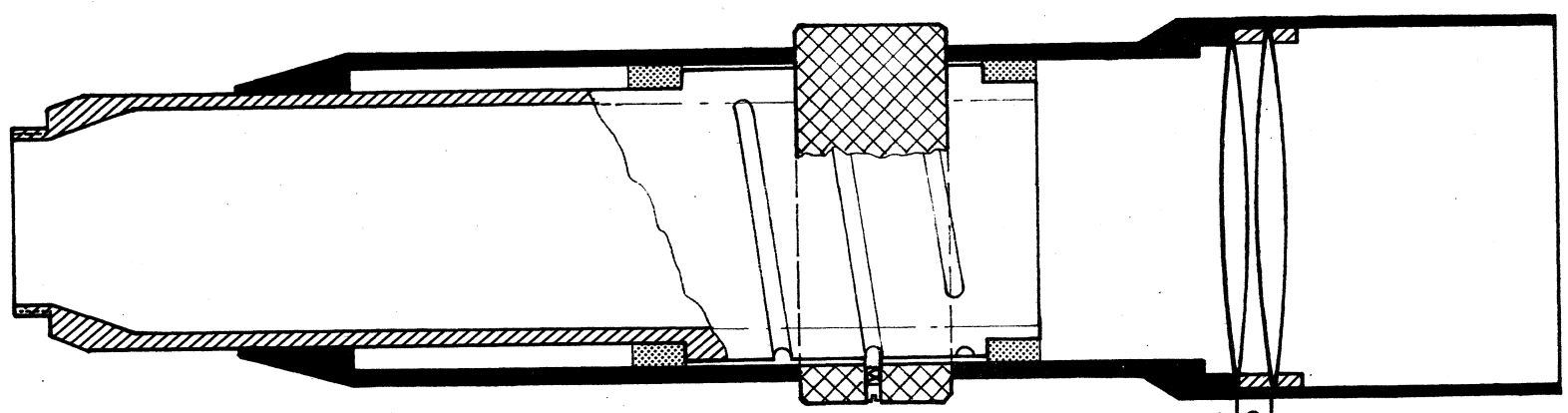

FIG.11

$$\frac{S}{V} = -\frac{a}{b}$$

$$\frac{1}{f} = \frac{1}{a} + \frac{1}{b}$$



$$f = \frac{f_1 f_2}{f_1 + f_2 - e}$$

'HOME MADE' LENS

FIG.12

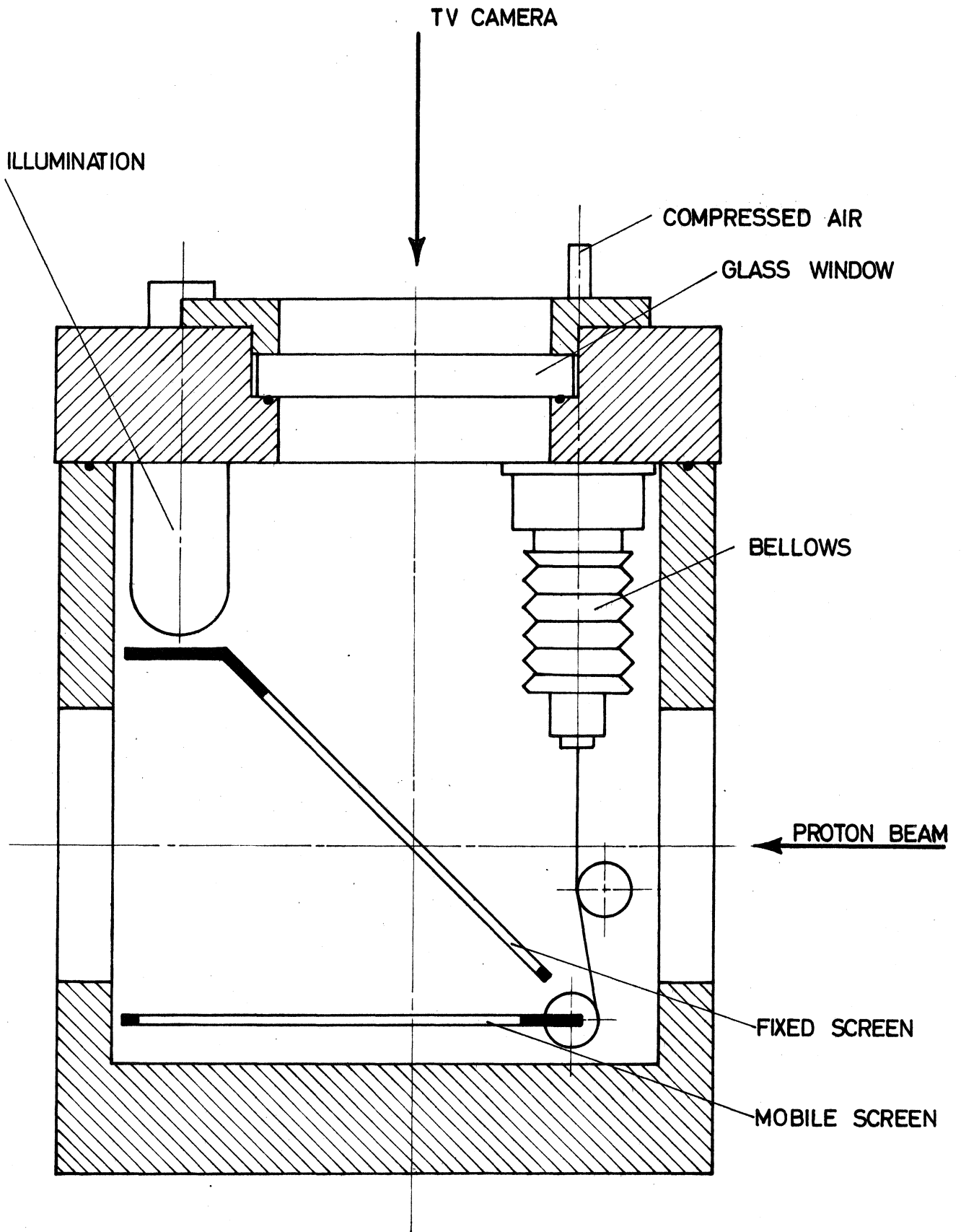

FLIPPING SCREEN MECHANISM

FIG. 13

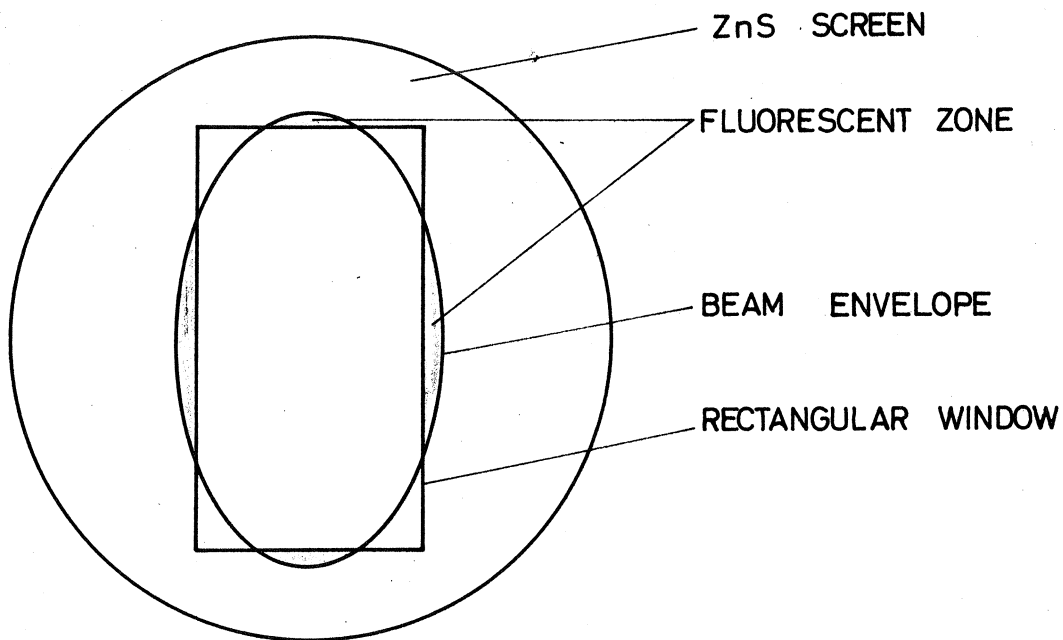

WINDOW DIMENSIONS FOR FIXED SCREEN

FIG. 14

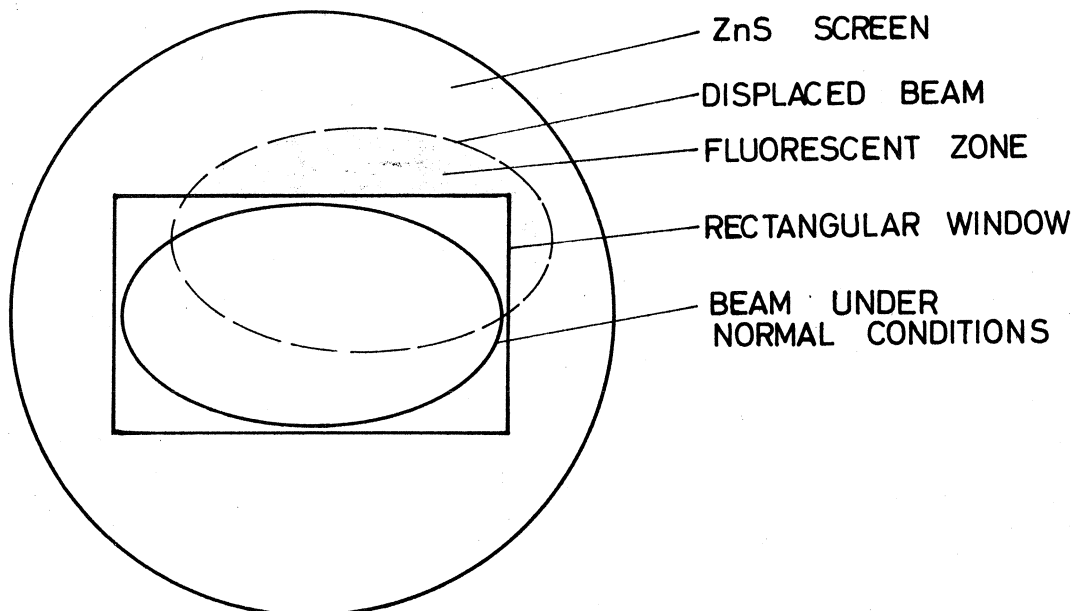

WINDOW DIMENSIONS FOR FLIPPING SCREEN

FIG. 15

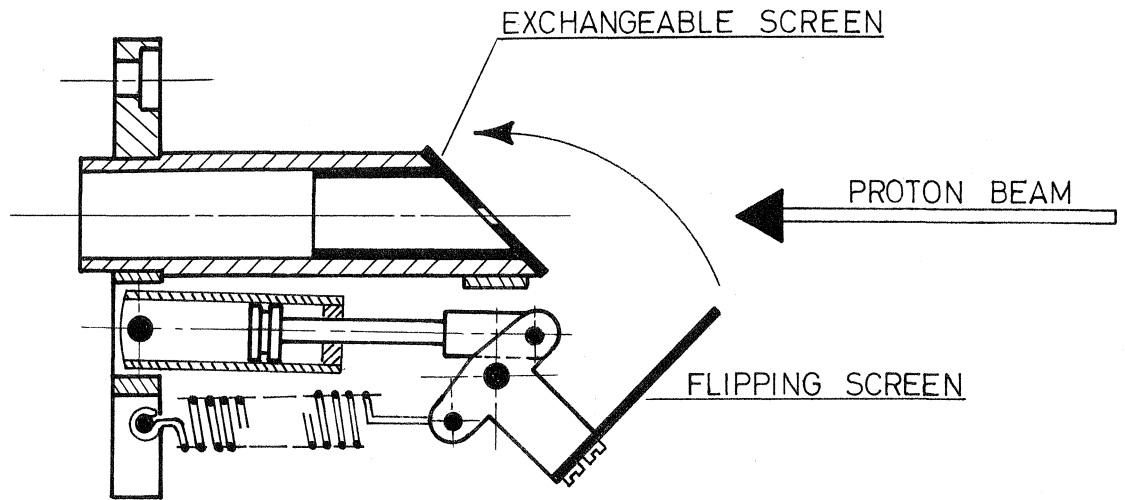

FLIPPING MECHANISM ON THE MAGNETIC HORN

FIG. 16

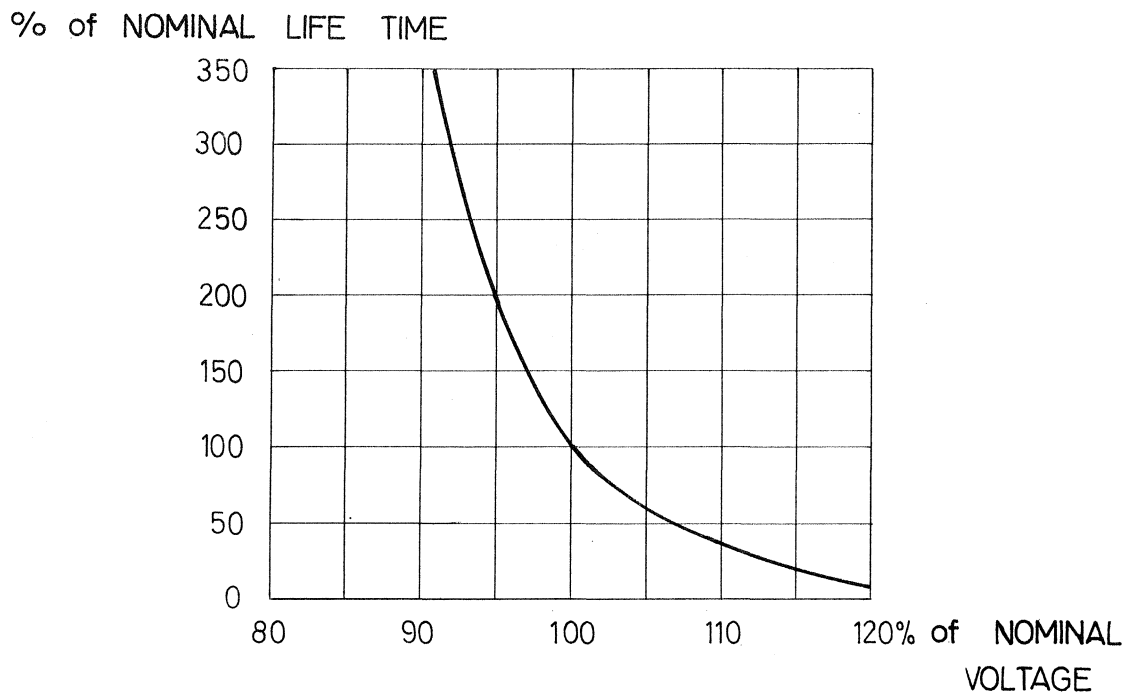

LIFE TIME CURVE FOR ILLUMINATION BULBS

FIG. 17



SCREEN TV 2



SCREEN TV 4



SCREEN TV 3

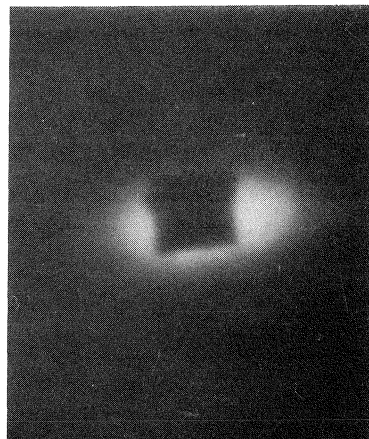

SCREEN TV 6
WITH WINDOW

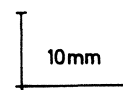

RADIOGRAPHS OF SOME SCREENS

FIG.18