

OPTICS OF THE EXTERNAL PROTON BEAM FOR THE P5 (ORSAY) EXPERIMENT

by

A.E. Ball - J.M. Maugain

INTRODUCTION

This report describes the beam optics for the fast ejected external proton beam (South East Area) proposed for the P5 (Orsay) experiment. The beam transport system operates with small aperture pulsed quadrupole and deflecting magnets ¹⁾. The experiment, which uses two mass spectrometers, is to measure the production cross sections and lifetimes of isotopes of the alkali metals in various target materials ²⁾.

Since the experiment is scheduled between two periods of running time for the K 11 - HLBC experiments, and utilises the same external proton beam transport line ³⁾, it was necessary to design the beam :

- a) using, as far as possible, the same equipment that is installed for the K 11 experiment;
- b) using a minimum of additional equipment and only that which is currently available;
- c) keeping the amount of equipment to be moved in the short periods between the experiments to a minimum;
- d) preventing primary beam irradiation of equipment downstream of the P5 target assembly.

1. SOURCE CHARACTERISTICS

The beam waists at the centre of SS. 74 in the CPS are taken as the origin of the beam transport system with betatron wavelengths of :

$$\beta_H = 12.0 \text{ m}$$

$$\beta_V = 21.7 \text{ m}$$

and a horizontal momentum compaction function $\alpha_p = 2.3$ m. No consideration has been taken of the optical effect of the ejection kicker magnet.

The beam is deflected from the machine by septum magnet 74 and passes through the fringe field of M.U. 74.

Matrices of the fringe field have been computed with the FORTRAN program TRAJ (W104) ^{3,4)}.

$$\begin{bmatrix} 2.34659 & 9.77628 & 0.12594 \\ 0.55556 & 2.74070 & 0.06094 \\ 0.07301 & 3.12395 \\ -0.32552 & -0.23158 \end{bmatrix}$$

The beam is effectively shielded from the stray field in M.U. 75 by means of a thick walled mild steel tube.

The beam emittance in both planes has been taken as $1.6 \mu\text{m}\cdot\text{rad}$. Experience with the primary beams for the neutrino and K 11 experiments has shown this figure to correspond well with the observed beam sizes, and to include some measure of safety for beam position fluctuation at the entrance to the transport system.

2. TARGET CONDITIONS

The experimental assembly consists of two similar targets, 4.0 mm width, 14.0 mm height, 4.0 mm length, separated by a distance of 1.15 m.

In order to have identical conditions at both targets, a focus must be provided in both planes mid-way between the targets. This focus position is 2.175 m downstream from point 8 (neutrino tunnel co-ordinates).

3. OPTICAL CALCULATIONS

In order to provide the beam focus at the target position, an additional quadrupole doublet placed 3.85 m downstream of point 7 was considered, using 50 cm long quadrupoles (Q 10/11) with a separation of 2 m. With this configuration a beam focus has been computed using the FORTRAN program FOCPAR^{5,6)}. The calculated beam radii at the targets are :

1.36 mm (horizontally), 3.11 mm (vertically)

The beam is identical with the proton beam for the K 11 experiment up to the doublet Q 5 / Q 6.

Quadrupoles Q 7 and Q 8 are also energised to transport the primary beam through the downstream magnet installation for the K 11 beam, for dumping in the shielding at the end of the tunnel.

Beam profiles for the two planes are shown in figure 1 and magnet fields are given in Table 1.

4. INSTALLATION

In order to have steering adjustment of the beam onto the targets, the vertical and horizontal deflectors of the final magnet assembly for the K 11 beam, VD 3 and HD 8 are moved upstream onto the support girder for Q 10 and Q 11. A drawing of the assembly is shown in drawing NPA 224-373-1. The complete beam layout is shown in drawing NPA 224-372-0.

CONCLUSIONS

The proposed layout provides for a beam at the target assembly within the target dimension given. Two additional 60 x 500 mm quadrupoles are required with power supplies and these are available. Two deflectors have to be moved between the K 11 and P5 experiments. The beam passes through the magnets downstream of the P5 target.

Distribution : (open)

Scientific staff of N.P.A.

Table 1

Gradients and fields are given for $E_p = 20 \text{ GeV}/c$

ELEMENT (Aperture mm)	K (m^{-2})	dB/dr (T/m)	B (pole tip) (T)
Q 1 (40)	- 0.823600	57.4642	1.149
Q 2 (40)	+ 0.466500	32.5486	0.651
Q 3 (60)	- 0.288900	20.1571	0.605
Q 4 (60)	+ 0.288900	20.1571	0.605
Q 5 (60)	- 0.235432	16.4266	0.493
Q 6 (60)	+ 0.209205	14.5967	0.438
Q 10 (60)	+ 0.424924	29.6478	0.889
Q 11 (60)	- 0.597559	41.6929	1.251
Q 7 (60)	- 0.300000	20.9316	0.628
Q 8 (60)	+ 0.300000	20.9316	0.628
Q 9 (40)	0.000000	0.0000	0.000

K + = horizontally defocusing

K - = horizontally focusing

HD 2/3/4/5 $\theta = 16 \text{ mrad}$ B = 0.997 T.

REFERENCES

1. B. Langeseth - A pulsed beam transport system for the external beam of the CERN Proton Synchrotron, CERN 64-35.
2. Klapisch Group - Orsay - private communication
3. J.M. Maugain - Transport du faisceau de protons externe pour l'expérience K 11, NPA-Int. 67-22.
4. R. Keyser - Particle trajectories in the CPS magnetic field computed by a FORTRAN program (TRAJ) CERN 6000 Series Library W 104.
5. R. Billinge - A computer program for the design of periodic focusing lattices and beam transport systems, ISR/300-GS/67-43
6. A. Ball - A modified version of FOCPAR for beam transport systems, NPA/PBT-69-1.

TARGET DIMENSIONS

4 mm horizontal
 1/4 mm vertical
 4 mm axial

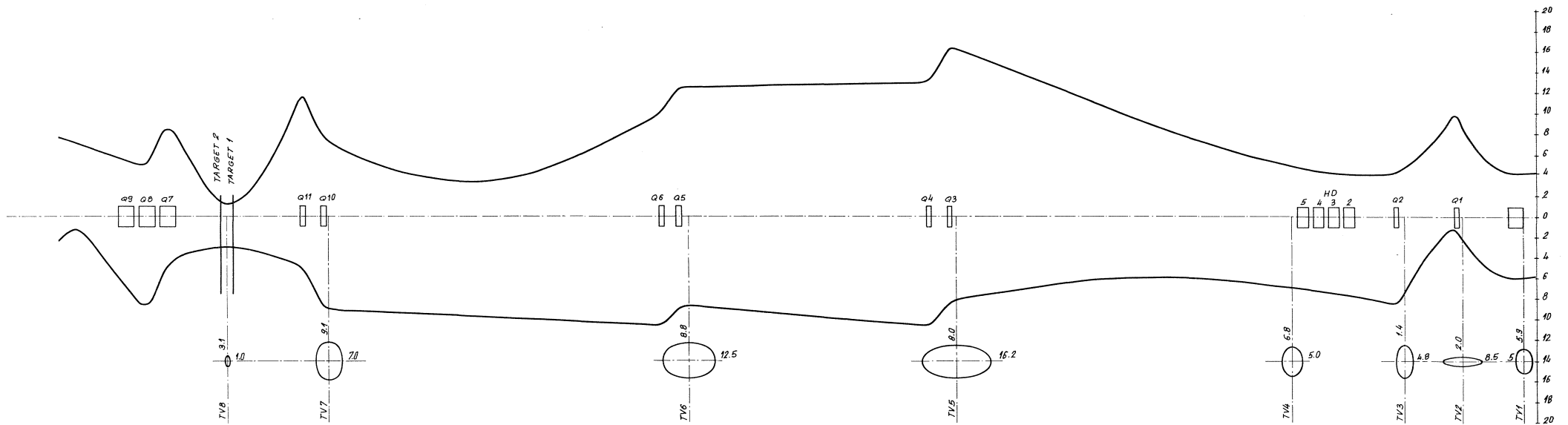
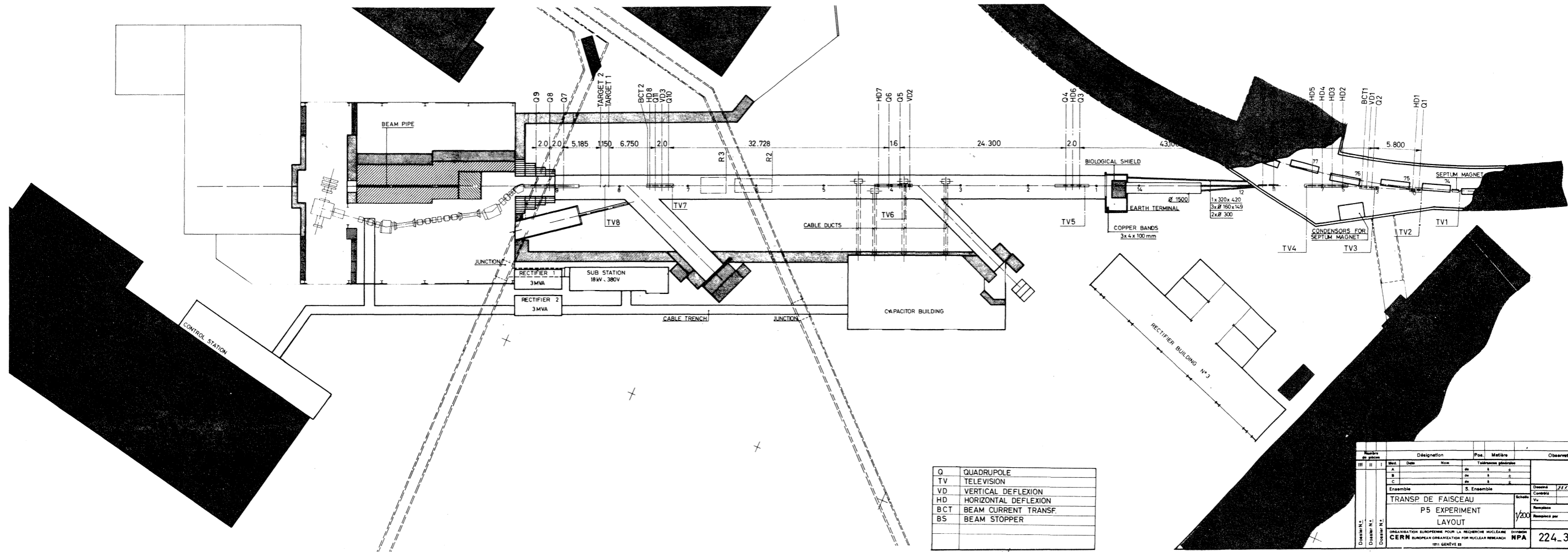

Fig. 1.

BEAM PROFILES OF THE EXTERNAL PROTON
 BEAM FOR THE P5 EXPERIMENT



Q	QUADRUPOLE
TV	TELEVISION
VD	VERTICAL DEFLEXION
HD	HORIZONTAL DEFLEXION
BCT	BEAM CURRENT TRANSF.
BS	BEAM STOPPER

N°	II	I	Date	Désignation	N°	Tolérance géométrique			Observation
						de	à	à	
				Ensemble		S. Ensemble		Dimens	21.1.77
				TRANSP. DE FAISCEAU		S. Ensemble		Contrôle	
				P5 EXPERIMENT		S. Ensemble		Remarque	
				LAYOUT		S. Ensemble		Remarque	
				ORGANISATION EUROPÉENNE POUR LA RECHERCHE NUCLEAIRE		S. Ensemble		Remarque	
				CERN EUROPEAN ORGANIZATION FOR NUCLEAR RESEARCH		S. Ensemble		Remarque	
				1971 GENÈVE 23		S. Ensemble		Remarque	
								224_372_0	

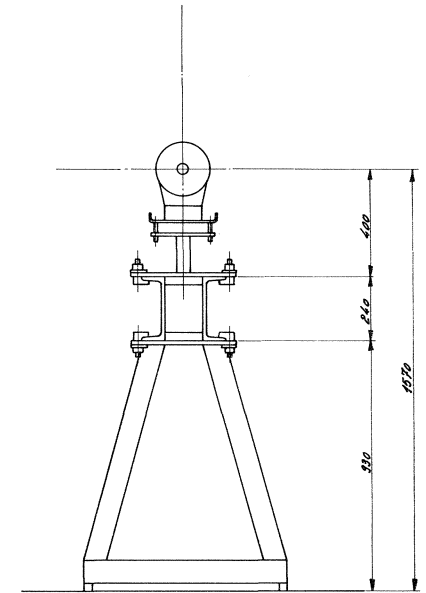
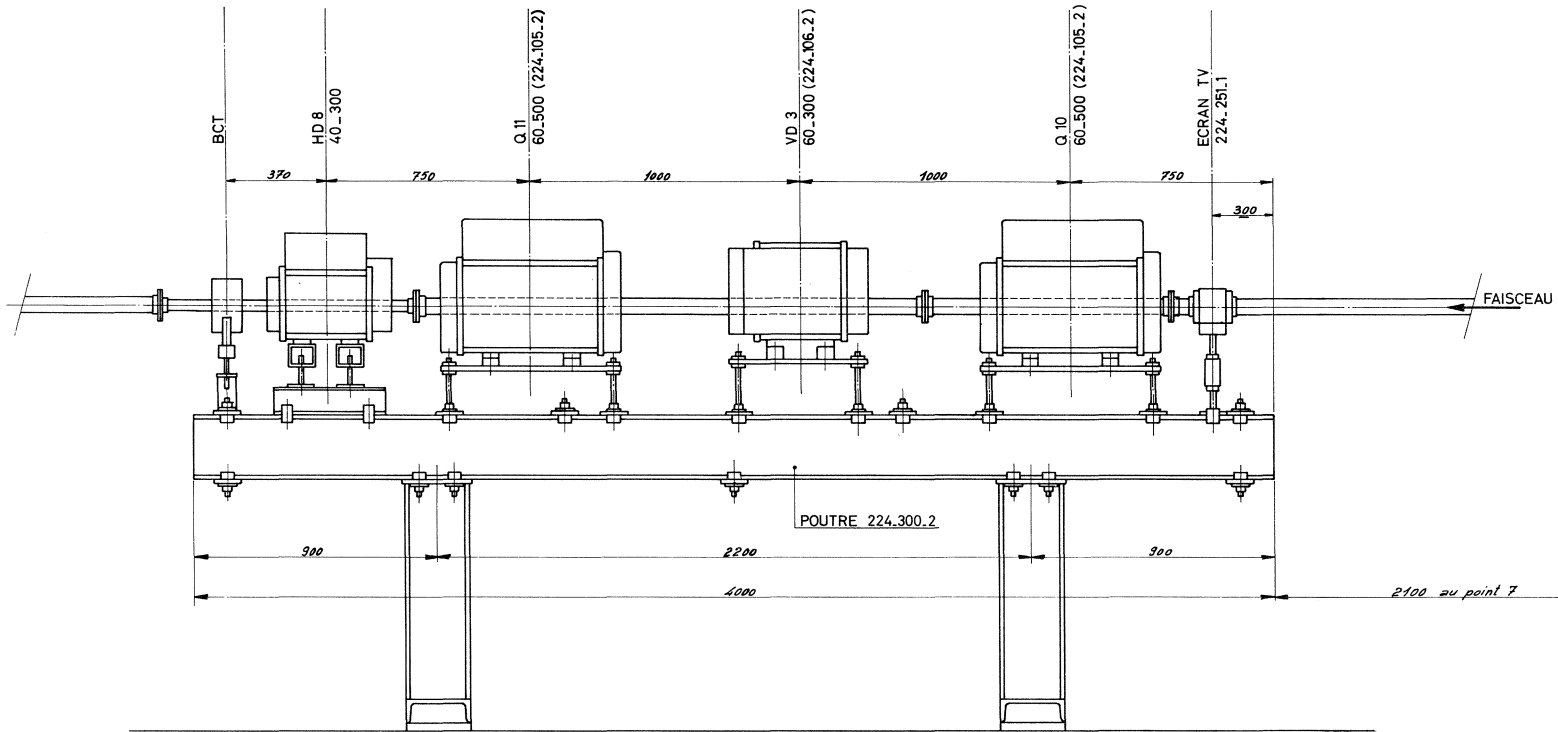

Nombre de pièces		Désignation		Pos.	Matière	Observations
III	II	I	Mod. Date	Nom	Tolérances générales	
			A	de à ±		
			B	de à ±		
			C	de à ±		
Ensemble				S. Ensemble		Dessiné 28.1.13 <i>PP</i>
PULSE BEAM TRANSPORT						Contrôle
EXPERIENCE P5						Vu
POUTRE INTERMEDIAIRE						Remplace
						Remplacé par
Dossier N°:						Echelle 1/10
Dossier N°:						
Dossier N°:						
ORGANISATION EUROPEENNE POUR LA RECHERCHE NUCLEAIRE DIVISION CERN EUROPEAN ORGANIZATION FOR NUCLEAR RESEARCH NPA						224_373_1
1211 GENEVE 23						