



European Coordination for Accelerator Research and Development

PUBLICATION

FMC-based Neutron and Gamma Radiation Monitoring Module for xTCA Applications

Kozak, T (TU Lodz, Poland) *et al*

06 December 2012

The research leading to these results has received funding from the European Commission under the FP7 Research Infrastructures project EuCARD, grant agreement no. 227579.

This work is part of EuCARD Work Package 4: **AccNet: Accelerator Science Networks**.

The electronic version of this EuCARD Publication is available via the EuCARD web site
<<http://cern.ch/eucard>> or on the CERN Document Server at the following URL :
<<http://cds.cern.ch/record/1498091>>

FMC-based Neutron and Gamma Radiation Monitoring Module for xTCA Applications

Tomasz Kozak, Dariusz Makowski, Andrzej Napieralski
Department of Microelectronics and Computer Science
Technical University of Lodz
Lodz, Poland
email: tkozak@dmcs.pl

Abstract—The machines used in High Energy Physics (HEP) experiments, such as accelerators or tokamaks, are sources of gamma and neutron radiation fields. The radiation has a negative influence on electronics and can lead to the incorrect functioning of complex control and diagnostic system designed for HEP machines. Therefore, in most cases the electronic equipments is installed in radiation-safe areas, but in some cases this rule is omitted to decrease costs of the project. The European X-ray Free Electron Laser (E-XFEL), being under construction at DESY research center, is a good example. The E-XFEL uses single tunnel and part of the electronic system will be installed next to main beam pipe and exposed to radiation. The modern Advanced/Micro Telecommunications Computing Architecture (ATCA/ μ TCA) standards are foreseen as a base for control and diagnostic system for this new project. These flexible standards provide high reliability, availability and usability for the system which can be decreased by negative influence of parasitic radiation field. The additional shielding will be introduced to protect racks with electronics, but during commissioning and, in case of control systems errors, the assumed radiation levels can be exceeded. Therefore, it is highly recommended to monitor doses absorbed by electronics. Moreover, it could be helpful for estimating system lifetime, scheduling maintenance periods and protecting machine from unexpended failures. The paper describes a Radiation Monitoring Module (RMM) based on FPGA mezzanine card standard capable of monitoring gamma radiation and neutron fluence in real-time.

Index Terms—Micro Telecommunications Computing Architecture, FPGA Mezzanine Card, RF Control System, gamma radiation dosimetry, neutron radiation dosimetry, linear accelerator, X-ray Free Electron Laser

I. INTRODUCTION

The High Energy Physics experiments use sophisticated machines like linear and circular colliders, linear accelerator or tokamaks. The electronic systems needed to control them must fulfil very strict requirements concerning computation power, flexibility, reliability and availability. Therefore, old system architectures such as VME are slowly substituted by modern ones. The Advanced Telecommunications Computing Architecture (ATCA) and Micro Telecommunications Computing Architecture (MTCA) - xTCA family - gain popularity in many leading research centres. The Deutsches Elektronen-Synchrotron (DESY), Joint European Torus (JET), CERN or SLAC consider one of the xTCA standards as a base architecture for their control systems [1].

The HEP machines are sources of gamma and neutron parasitic fields. In most cases control electronic is highly isolated from them to avoid destructive influence by placing it in radiation-safe areas. The European X-ray Free Electron Laser (E-XFEL) is a good example of the exception. In order to decrease the cost of the project, it will use a single tunnel and most of the control system electronics will be placed in the same tunnel as the main beam pipe. Therefore, the control system will be exposed to gamma and neutron fields generated by the machine [2]. The parasitic radiation produced during accelerator operation could have a negative influence on electronics reliability and therefore machine availability. The negative influence of radiation on electronics has been proven by many research [3][4]. The electronic equipment will be installed in shielded racks. The FLASH accelerator was used to measure doses of radiation and to design the radiation shielding for electronics [5].

A radiation monitoring system capable of measuring doses absorbed by electronics inside the rack could be helpful during accelerator studies and commissioning. It can also help to schedule the maintenance periods in more effective way which could decrease costs of accelerator operation.

II. E-XFEL AS AN EXAMPLE FOR REQUIREMENTS FOR RADIATION MONITORING SYSTEM

The E-XFEL accelerator will consist of 116 accelerating modules and other special components such as bunch compressors or arrays of magnets. Each single RF station will be driving four accelerating modules [2]. The electronics required for the Low Level RF (LLRF) system responsible for controlling the parameters of the accelerating field and for other diagnostic systems will be placed in the shielded racks distributed along the tunnel. Therefore, a distributed architecture of radiation monitoring system is recommended. The on-line accessibility of measurement data is required, because it is impossible to enter the linac tunnel during normal operation of the machine. The measured data should be collected in an external database for further analysis. The dosimeters for the system should fulfill the requirements

presented in Table I [4]. The developed radiation monitoring system will have a distributed architecture and need to be integrated with control system of the E-XFEL which will be based on one of the xTCA architecture. The xTCA family has been designed for telecommunication industry.

TABLE I. REQUIREMENTS FOR GAMMA RADIATION AND NEUTRON FLUENCE DOSIMETERS

Detection ability	Gamma and neutron fluence
Fluence range	$10^6 - 10^{10}$ neutrons·cm ⁻²
The lowest fluence	$10^4 - 10^5$ neutrons·cm ⁻²
Dose range	$10^2 - 10^3$ Gy
The lowest dose	$10^{-3} - 10^{-2}$ Gy
Energy range	up to 20 MeV

Therefore, nowadays an additional effort is made to fit xTCA into specific requirements of HEP experiments. As a result of this work the PICMG ‘xTCA for Physics’ standard extension has been introduced. To provide bigger flexibility and reusability of the electronics an additional standard was developed. The FPGA Mezzanine Card (FMC) specification (ANSI/VITA 57.1-2008) has been proposed. The standard defines form factor of PCB and pinout of the FMC connector [6]. As a main idea the FMC modules carry the unique electronic components which provide front-end functionality in the system, but not computation power and communication interfaces which are supplied by a Carrier Board (CB). The CB could have different form factors such as standalone boards or Advanced Mezzanine Card (AMC) which fits the FMC standard into xTCA. The FMC carrier module is already a part of the LLRF control system. Therefore, the solution where the radiation dosimeters and readout sub-circuits will be designed as a FMC module has been chosen. It can be easily integrated with control system electronics and readout infrastructure.

III. RADIATION MONITORING FMC MODULE

A. Dosimeters for FMC Radiation Monitoring Module

Various dosimetry methods allows to detect and measure radiation doses. They are based on a wide spectrum of electrical, thermal, luminescent and chemical effects triggered by radiation in different kind of materials. They include gaseous detectors, scintillators, bubble dosimeters and thermoluminescent dosimeters (TLD) [4]. Detectors chosen for the designed module should provide a good selectivity, dynamic ranges and cover dose ranges specified in Tab. 1. Moreover, selected dosimeters need to have small dimensions to decrease occupied space volume and their readout circuit should not utilize high voltages, which are not available in the xTCA standards. The semiconductor-based dosimeters seems to be natural candidates which fulfill two latter requirements. Therefore, the Radiation sensitive Field Effect Transistor (RadFET) was chosen as gamma radiation dosimeter.

The principle of operation of the RadFET dosimeter is based on the electron-hole generation process present in the transistor oxide layer exposed to gamma radiation and, in minority, by neutrons through secondary effects. It leads to charge build-up which influences the electric parameters of the device such as threshold voltage [3]. The shift of threshold voltage is a function of absorbed dose. The process occurs faster in P-type devices, thus RadFETs are P-type transistors. The sensitivity of the device to radiation shows dependence on the oxide layer thickness and can be adjusted due to application requirements. The RadFET operates in two modes – irradiation and reader. In the former one the source and drain of the transistor are shorted. The voltage on the gate is called the bias voltage (V_{bias}) and has significant influence on the device sensitivity. This feature allows to adjust the sensitivity and dose ranges on-the-fly. For threshold voltage readout the transistor needs to be switched to the reader mode. The typical readout circuit is presented in Figure 1. In this mode the transistor source is connected to a constant current source and the constant current flows through the device. The measured voltage shift allows calculating the absorbed gamma radiation dose.

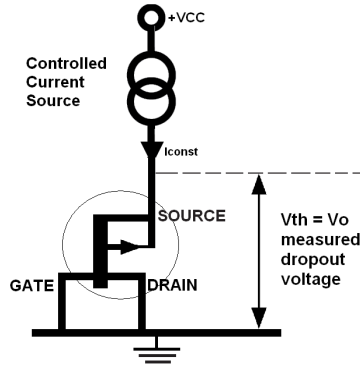

Figure 1. RadFET dosimeter readout circuit

The main advantages of RadFET are small size of the detector, simple readout circuit and low unit cost. The biggest disadvantage is temperature dependence which can be mitigated by setting current to Minimum-Temperature-Coefficient (MTC) value. Several RadFETs available on the market, produced by different companies, have been analyzed to determine the gamma detector most suitable for the FMC module. The example of RadFETs has been presented in Figure 2. The RFT-300-CC10G1 produced by REM Oxford Ltd. has been finally selected. The device has 0.3 μm oxide. The sensitivity parameters for the REM RadFETs family are presented in Table II [7].

TABLE II. RESPOSIVITY FOR DIFFERENT EXPOSURE MODES IN FUNCTION OF OXIDE THICKNESS

t_{ox} [μm]	Sensitivity [mV/cGy]		
	$V_{\text{bias}} = 9 \text{ V}$	$V_{\text{bias}} = 18 \text{ V}$	$V_{\text{bias}} = 0 \text{ V}$
0.2	0.65	0.85	0.12
0.25	0.95	1.20	0.16
0.3	1.25	1.75	0.20



Figure 2. RadFET dosimeters from REM Ltd. (two from left) and from Tyndall National Institute (two from right)

The gamma detector can be also used to detect neutrons, but special converters are essential for this process which makes the sensor much more complex [8]. This is not suitable for measuring neutrons in the fields with strong gamma background. To avoid this the neutron fluence measurement method will be based on counting the number of generated SEU events in specially selected SRAM memories. The previous researches proved that neutrons can trigger the SEUs in the digital memories. Moreover, the number of generated errors can be recalculated to the value of fluence intensity [9]. The SEU can be easily detected by consecutive memory scanning when the reference pattern stored in the memory is known. The sensitivity of the SRAM depends on many parameters such as manufactured technology, size, supply voltage and vendor. Several memories have been tested to determine the most suitable chip. The research proved that the newer memories are more immune to radiation than the older ones. Moreover, sensitivity can be increased by decreasing the supply voltage below the value specified in the datasheet [4]. Advantages of SRAM memories include accessibility, digital interface and low cost of the unit. Unfortunately, each chip should be calibrated with a reference neutron source which is the main disadvantage of chosen method. For needs of the project the 512 kB Samsung K6T4008C1B SRAM has been chosen.

The selected dosimeters can be easily integrated with digital readout subsystems, represent low unit cost and high selectivity, which is an important factor in radiation mixed environment characteristic for linear accelerators.

B. Radiation Monitoring Module hardware

The designed FMC Radiation Monitoring Module has a single width form factor with Low Pin Count (LPC) connector. The chosen factor limits available area on the PCB, but makes the module more compact and compatible with all solutions which support the FMC standard.

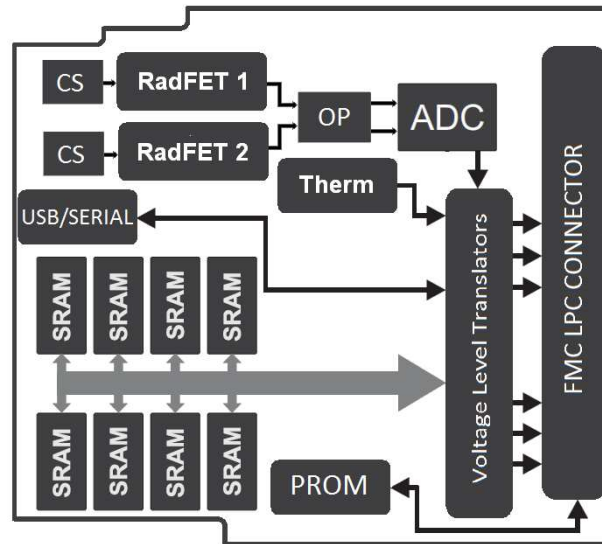

Figure 3. FMC Radiation Monitoring Module block diagram (CS - current source, OP - operational amplifier, Therm – digital temperature sensor)

The module is divided into two sections – analog and digital. The first one holds two RadFETs used as gamma radiation dosimeters. Each detector has a separate readout circuit. Individual adjustable current sources feed each of the transistors with a constant current of $490 \mu\text{A}$. It is the MTC value for the selected type of RadFETs [7]. The current sources are supplied from $+11.5 \text{ V}$ power supply which sets the upper threshold voltage (V_{th}) level which can be achieved on the irradiated RadFETs. The maximum V_{th} value together with sensitivity value determine the maximum doses which can be detected by the designed detector. Both of the detectors has an adjustable bias voltage (V_{bias}) used in irradiation mode. The $+10 \text{ V}$ or 0 V can be chosen and for one of the FETs this value can be changed on-the-fly. It provides a possibility to configure the detector with different sensitivity levels. Utilization of different V_{bias} values allow to receive coarse and fine type of measurement. The device with positive bias will provide more precise data due to larger sensitivity, but lifetime of the detector will be shorter than with $V_{bias} = 0 \text{ V}$. The voltage signal from RadFET in reader mode (see Fig. 1) is passed, through an operation amplifier configured as a voltage follower, into an analog to digital converter (ADC) which close the analogue path of the signal. Selected ADC has a 16-bit resolution and provides data from two independent channels by digital serial interface in TTL standard.

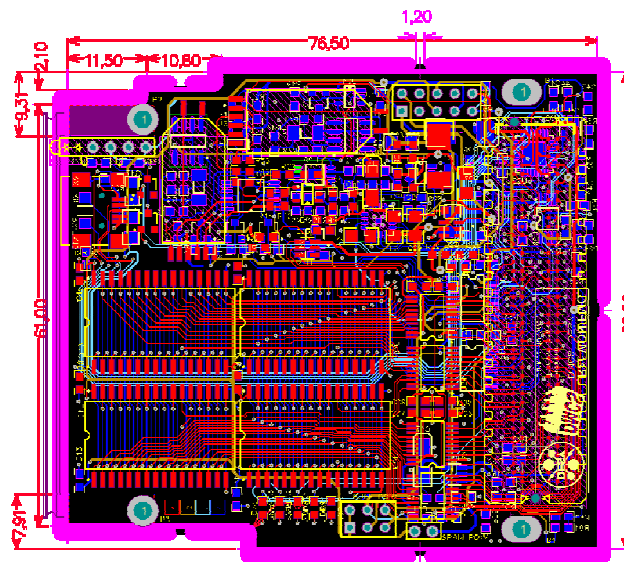

Figure 4. FMC Radiation Monitoring Module PCB layout

The digital section, besides the mentioned temperature sensor, includes eight Samsung SRAM K6T4008C1B memories, with a total capacity of 4 MB. The memory is used as neutron fluence detector. The normal operation supply voltage is decreased from $+5 \text{ V}$ to increase sensitivity of detector. The values from $+1.8 \text{ V}$ to $+3.3 \text{ V}$ can be applied

depending on the used batch of memory. Additional integrated circuits mounted on the FMC are serial PROM memory required by FMC standard and simple USART-USB converted to provide a flexible communication channel between control logic and the external world. The electronics on the FMC use TTL logic standard for ADC and thermometer chips and voltages from 1.8 V to 3.3 V (depends on configuration) for SRAM digital interface. The set of buffers has been introduced to provide voltage level conversion between FMC logic standards and logic standard used on the carrier board. After conversion all signals are passed directly to the FMC connector.

The designed FMC module, which PCB layout is presented in Figure 4. , does not provide any computation power or supply voltages, therefore it needs to be connected to an additional board called carrier board. The FMC standard assumes that the computation power, communication interfaces and supply power will be provided by FPGA-based CB. Nevertheless, each board equipped with an FMC connector and compliant with FMC specification as far as the signal layout on the FMC connector is concerned, can be used as a carrier. The versatile AMC carrier DAMC2, designed at DESY, will be used as the carrier board for the described FMC Radiation Monitoring Module. The DAMC2 is general purpose carrier proposed for different applications in the E-XFEL Machine Protection Systems [10]. The FMC module is also compliant with some Xilinx evaluation kits such as SP605 or ML605 which provides a suitable development platform for the firmware and software needed for the Radiation Monitoring System.

C. FMC Radiation Monitoring Module firmware structure

The designed module was in fabrication stage during preparation of this paper. Nevertheless, the firmware architecture for FPGA-based CB was designed. The block diagram of VHDL modules implemented in the FPGA is presented in Figure 5. The SPI_ADC_DRIVER and THERM_SPI_DRIVER are dedicated blocks which perform a role of driver for the ADC and thermometer used in the project. The driver for each chip will provide a possibility to write configuration register in each device and read measurement data. The third driver needed is SRAM_DRIVER which will be able to write to and read data from K6T4008C1 SRAM memory. The ADC_CTRL and THERM_CTRL, which together can be considered as the RadFET controller, are responsible for providing higher level logic.

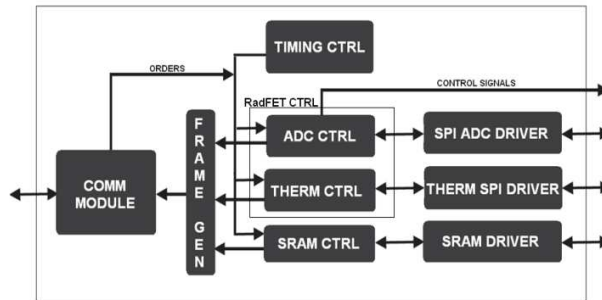

Figure 5. Block diagram of VHDL modules for Radiation Monitoring FMC

They control, initialize and gather data from ADCs and thermometers. The data from ADCs needs to be gathered every several minutes. The TIMING_CTRL module is designed to measure the time periods between consecutive measurements and generate trigger signals for others VHDL modules. The RadFET controller will change the mode of the transistors from irradiation to reader mode and perform the voltage and temperature readouts. Afterwards, the gathered raw data should be transferred to the frame generator module (FRAME_GEN), where communication frames are created according to the custom communication protocol. Each frame will carry information about module ID number, type of frame, raw data and calculated checksum. Then, the frames will be transferred to the communication module (COMM_MODULE) responsible for building frames in communication standard used in the system via PCIe bus. The SRAM_CTRL block will constantly scan connected SRAM memories in order to find SEUs generated by neutrons. The number of detected SEUs can be accessed via a register. The modular construction of the code allows making fast changes in the project such as changing communication interface.

IV. CONCLUSIONS AND PLANS

Presented FMC Radiation Monitoring Module provides two types of dosimeters suited for gamma and neutron field measurement in an xTCA-based system which can be exposed to these kinds of radiation. It may concern control systems in High Energy Physics facilities such as linear accelerators, colliders, tokamaks, where control electronics can be exposed to radiation. The prepared module can be easily integrated with system based on xTCA and FMC standards. It can be also used in an independent system with suitable standalone carrier board. It makes it highly flexible and reusable which decreases costs and is the main advantage of the proposed solution. Also, low cost of single unit, simple digital interface, good selectivity and ranges of proposed dosimeters speak in favor of this design. The module requires a calibration routine and has limited lifetime which can be consider as the main drawbacks.

In the near future the module should be assembled, tested and ready for calibration. The test will be performed at DESY research center.

ACKNOWLEDGMENT

The research leading to these results has received funding from the European Commission under the EuCARD FP7 Research Infrastructures grant agreement no. 227579.

REFERENCES

- [1] B. Goncalves et al., "ATCA Advanced Control and Data acquisition systems for fusion experiments", 16th IEEE-NPSS Real Time Conference, 2009
- [2] M. Altarelli et al., "The European X-Ray Free-Electron Laser Technical design report", 2006
- [3] G. Barbottin, A. Vapaille, "Instabilities in Silicon Devices, New Insulators, devices and Radiation Effects", Elsevier, 1999
- [4] D. Makowski, "The impact of Radiation on Electronic Devices with the special consideration of Neutron and Gamma Radiation Monitoring", PhD Thesis 2007.
- [5] F. Schmidt-Foehre et al., "A new embedded Radiation Monitor System for Dosimetry at the European XFEL", Proceedings of IPAC2011, 2011
- [6] ANSI/VITA 57.1-2008, "American National Standard for FPGA Mezzanine Card (FMC) Standard", July 2008
- [7] RFT-300-CC10G1 datasheet, REM Oxford Ltd., September 2009
- [8] T.E. Manson., "Neutron detectors for materials research. Technical report", OAK Ridge National Laboratory, 2000.
- [9] D. Makowski et al., "The Application of SRAM Chip as a Novel Neutron Detector", NSTI-Nanotech 2005 Proceeding, 2005
- [10] P. Vetrov, "Versatile AMC for XFEL Machine Control", ATCA Workshop presentation, RT2010, 2010