



European Coordination for Accelerator Research and Development

PUBLICATION

Modified 3-Cell SC Cavity Made of Large Grain Niobium for the FZD SRF Photoinjector

Murcek, P (FZD) *et al*

22 April 2010

The research leading to these results has received funding from the European Commission under the FP7 Research Infrastructures project EuCARD, grant agreement no. 227579.

This work is part of EuCARD Work Package **10: SC RF technology for higher intensity proton accelerators and higher energy electron linacs.**

The electronic version of this EuCARD Publication is available via the EuCARD web site <<http://cern.ch/eucard>> or on the CERN Document Server at the following URL :
<<http://cdsweb.cern.ch/record/1260958>>

MODIFIED 3½-CELL SC CAVITY MADE OF LARGE GRAIN NIOBIUM FOR THE FZD SRF PHOTOINJECTOR*

P. Murcek[#], H. Buettig, P. Michel, K. Moeller, A. Arnold, J. Teichert, R. Xiang, M. Freitag, FZD, Dresden, Germany,
P. Kneisel, JLab, Newport News, USA

Abstract

An SRF photoinjector has been successfully tested in FZD under the collaboration of BESSY, DESY, FZD, and MBI. In order to improve the gun cavity quality and thus reach a higher gradient, a new 3+1/2 superconducting cavity is being fabricated in cooperation with JLab. The modified cavity is made of large grain niobium, composed of one filter choke, one special designed half-cell (gun-cell) and three TESLA cavities. In this paper, the main updates of the new cavity design will be explained in detail. The deformation of the filter choke and the gun-cell, which is caused by pressure fluctuation in the He-line and also by the effect of the Lorentz force, will be minimized by stiffening between the filter choke and the gun-cell. Meanwhile, the cathode hole in the choke and gun-cell is enlarged for better rinsing. To simplify assembly, the NbTi pick-up will be welded directly on the wall of filter choke.

INTRODUCTION

Superconducting RF photo electron injectors (SRF guns) possesses the potential for the production of high-brightness and high-average-current electron beams. They can produce short electron pulses with high bunch charges and low emittance similar to normal conducting RF photo injectors but can be easily operated in continuous wave (CW) mode. Therefore they are promising candidates for future accelerator based light source like FELs or ERLs. In comparison to superconducting acceleration cavities the integration of the photo cathode into the cavity is a great challenge. Further significant issues are the right selection of the photo cathodes type and their production, the driver laser system, fundamental RF power input coupling, higher-order mode suppression, and emittance compensation methods.

The first design of a SRF gun was presented in 1988 by the group of the University of Wuppertal [1] and a set-up with a 2.8 GHz elliptical half-cell cavity was installed [2]. Later at the FZD a SRF gun with a half-cell, 1.3 GHz TESLA style cavity was built in collaboration with DESY and BINP [3]. With this experimental setup, the first electron beam from an SRF gun could be produced and

stable operation over 7 week demonstrated [4]. In continuation of this development, a SRF gun with a 3 ½ cell cavity was designed and constructed for use at the ELBE superconducting linear accelerator. This gun was developed within the collaboration of HZB, DESY, MBI and FZD and has been in operation since 2007 [5]. The normal conducting photo cathode is thermally and electrically isolated from the cavity und cooled with liquid nitrogen. The photo emission layer is Cs2Te. Details of the SRF gun design have been published elsewhere [6].

During cavity treatment and gun assembly it turned out, that the main problem was the insufficient cleaning of the niobium cavity, especially of the half-cell and choke filter. Compared to TESLA acceleration cavities treated with buffered chemical polishing (BCP) [7], the achieved peak field of the gun cavity in the vertical test cryostat of about 25 MV/m was rather low and limited by field emission, although the treatment (50 µm BCP and HPR) was repeated four times [8]. Furthermore a scratch at the half-cell cathode boring was found, which could not be eliminated. Thus an improvement by further treatments was not expected and the cavity was welded into the He vessel and assembled in the SRF gun cryostat. After commissioning the SRF gun can now be operated at a peak field of 18 MV/m and an electron beam of 3 MeV can be produced with bunch charges up to 400 pC. Therefore beam can be delivered to the ELBE accelerator for several applications.

But the improvement of the beam quality und the extraction of bunches with higher charge depend essentially on the strength of the acceleration field in the cavity. This requires a new cavity for which the design specification with respect to quality factor and maximum acceleration gradient can be reached. To meet this goal is mainly a problem of improved cleaning of the cavity. But based on the experiences obtained during operation and measurements, some modifications of the SRF gun cavity seems to be useful. This paper presents the revised design and discusses the advantages.

PROPERTIES OF THE EXISTING CAVITY

Figure 1 shows a 3D model of the present 3½-cell SRF gun cavity. The cavity consists of the three TESLA-type shaped accelerating cells and the half-cell with the opening for the photo cathode which are made of RRR 300 niobium. Adjacent to the half-cell is the choke filter cell. In the beam tube on the right side there are two HOM couplers, the flange for the main power coupler,

* We acknowledge the support of the European Community-Research Infrastructure Activity under the FP6 programme (CARE, contract number RII3-CT-2003-506395), and the FP7 programme (EuCARD, contract number 227579), as well as the support of the German Federal Ministry of Education and Research grant 05 ES4BR1/8.

[#]p.murcek@fzd.de

and a pick-up antenna for the field amplitude and phase control. A second pick-up antenna in the choke filter cell serves as field probe for the half-cell. In the tube on the left side the cooper cooling and support unit for the photo cathode is visible. The star-like structure between the half-cell and the first TESLA cell is the fix point for the two tuners where the first tunes the half-cell and the second the three TESLA cells together.

Beside the regularly repeated Q_0 versus E_{acc} measurements, a series of cavity related measurement like tuning properties, He pressure influence, RF amplitude and phase stabilization, field profile flatness, Lorentz force detuning, and microphonics has been carried out during the past two years. In the following the attention should be focused on He pressure influence and Lorentz force detuning, and microphonics which are directly related to the cavity stiffness. In Table 1 the results are shown and compared to similar measurements for the ELBE cryomodules with standard TESLA cavities inside.

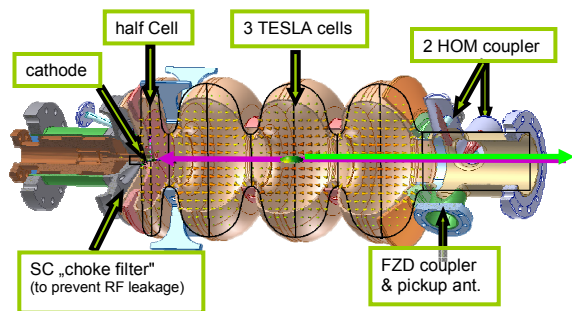

Figure 1: 3D model of the Rossendorf SRF gun cavity.

It is obvious from the results that the SRF gun cavity is much weaker and therefore more sensitive to surface forces. The reason for the higher values must be the half-cell since the three other cells are equal in shape and material to those in the TESLA cavity. At present, these values for the SRF gun cavity are acceptable since the gradient is low. But it is conceivable that the new cavity needs improvement in order to allow stable operation at the design gradient of $E_{peak} = 50$ MV/m.

Table 1: Comparison of parameters for the SRF gun cavity and for TESLA cavities in the ELBE cryomodules. (Details of the measurements are given in Ref. [9].)

	quantity	SRF gun cavity	TESLA cavity
He pressure sensitivity	$s_p = \Delta f / \Delta p$	230 Hz/mbar	35 Hz/mbar
Lorentz force Detuning	$k = \Delta f / E_{peak}^2$	-0.7 Hz/(MV/m) ²	-0.25 Hz/(MV/m) ²
RF phase noise by microphonics	σ (rms)	0.055°	0.05°

DESIGN MODIFICATION

In order to push the field emission limit to higher gradients the high pressure rinsing (HPR) of the cavity is essential. For the existing SRF gun cavity the HPR was performed from the beam tube side as it is schematically shown in Fig. 2a. On the cathode side this cavity has two small (12 mm diameter) holes, one in the wall between half-cell and choke filter, and the other in the back wall of the choke filter. The small hole does not allow that the HPR nozzle head can be moved in the choke filter cell and hampers the water flow out of the cell. The situation is similar worse for HPR cleaning from the upstream side as depicted in Fig. 2b.

For improvement at least one of the openings should be enlarged. This is possible for the hole in the choke filter back wall without significant changes in its RF properties, as it is shown in Fig. 3b (For comparison Fig. 3a shows the old design). Furthermore the hole in the half-cell wall is partly enlarged. That clears the space for the HPR nozzle head for rinsing the choke cell from the cathode side end. On the half-cell side, the cathode hole diameter is unchanged in order to avoid changes of the beam dynamic properties of the cavity. Beside these cavity design changes, a proper designed HPR nozzle head will be applied and attention will be paid to avoiding dangerous head vibrations.

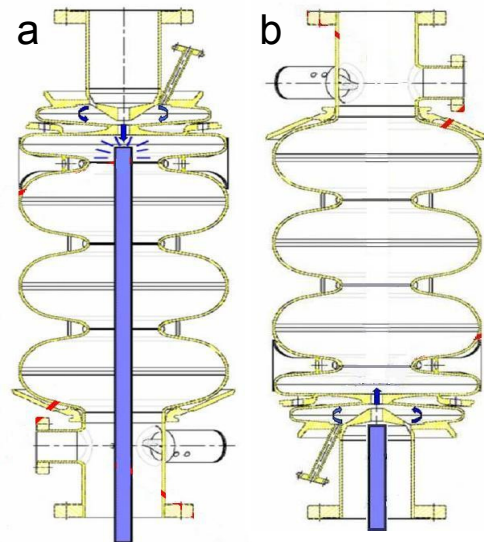

Figure 2: Schematics of the high pressure rinsing from the beam tube side a, and the cathode side b.

The particle pollution risk for the cavity can be furthermore reduced as the final assembly work in the clean-room is reduced or simplified. A critical point in the existing cavity was the mounting of the choke-cell antenna into the long tube (see Fig. 4a). In the new design, shown in Fig. 4b, the NbTi-flange for the feed-through is directly welded into the back wall of the choke

filter. This solution allows final cleaning with the mounted antenna.

As mentioned above, a stiffening of the half-cell in the new cavity is required. Especially the flat back wall disk has a low rigidity. For an improvement a new stiffening ring is designed which is placed between half-cell and choke filter. Fig. 5 shows the ring and the corresponding part of the cavity. This design modification considers that the thermal conduction in areas of high magnetic field is not reduced and that the liquid helium flow is ensured.

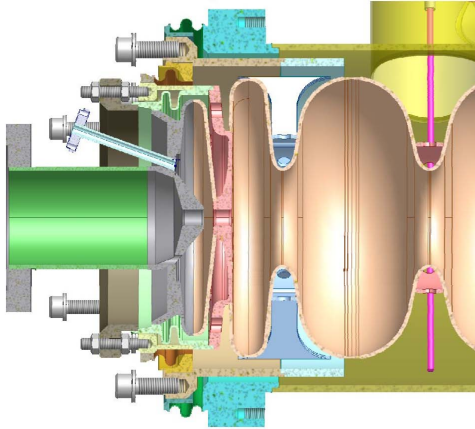

Figure 3a: Previous cathode opening design.

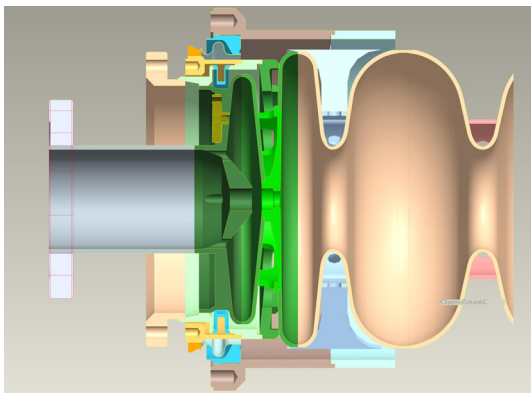

Figure 3b: New cathode opening design.

On the other hand it is important that the forces needed for the tuning of the half-cell do not exceed the limit of the existing tuner. For that reason 3D-simulations of the mechanical properties of the cavity were carried out. A welcome side effect of the new stiffening ring is an improved bending stability of the cavity since up to now the only joint between half-cell and choke filter cell was the thin cathode tube.

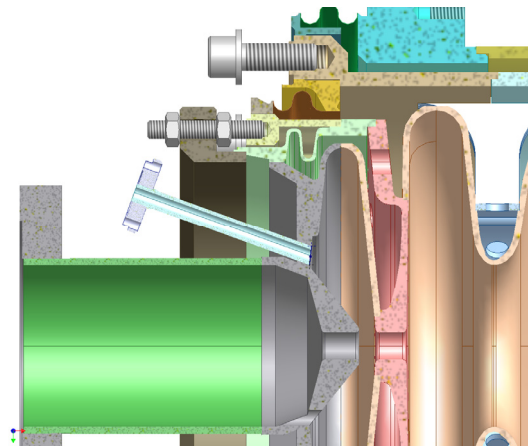

Figure 4a: Previous pick-up antenna design.

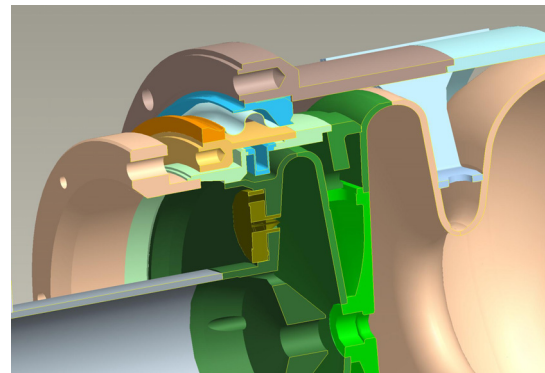

Figure 4b: New pick-up antenna design.

Further modifications concern the downstream end-group of the cavity. The reason is a proposal by Volkov and Janssen [10] for a new emittance compensation method in SRF guns. A RF wave will be additionally coupled into the cavity and will excite a higher order mode (TE mode) with focusing properties. This attempt will be experimentally investigated with the new cavity.

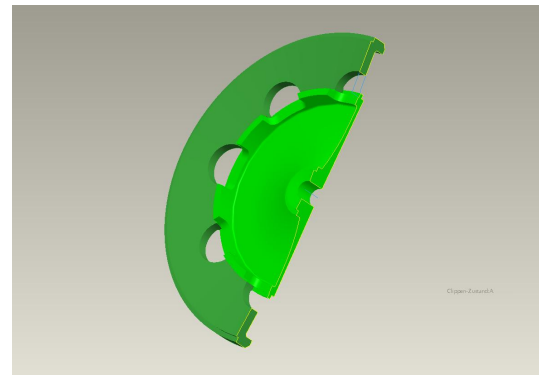

Figure 5a: Stiffening ring for the half-cell back wall.

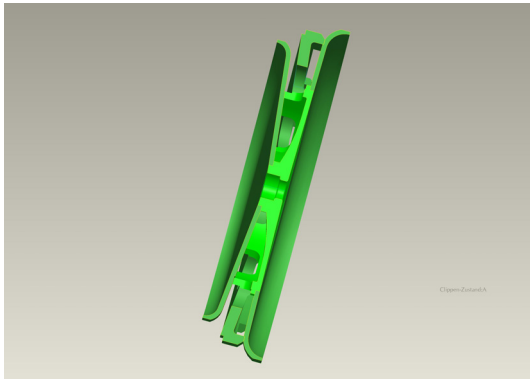

Figure 5b: Half-cell with the new stiffening ring.

The design of the modified end-group is presented in Fig. 6. It differs in the previous design that one of the two HOM couplers is now mountable (Saclay coupler). When dismantled, the free flange can be used for the input coupler of the TE mode. Furthermore a cone is inserted into the beam tube reducing the diameter from 78 mm to 40 mm. The existing cavity ends with a 78 mm beam tube flange and the reduction occurs downstream in the normal conducting beam tube. The new solution prevents the expansion of the TE mode into the normal conducting area where it would be strongly damped.

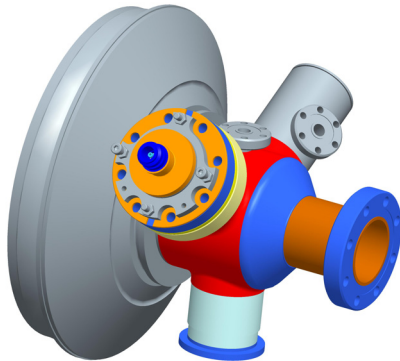

Figure 6: New end-group with beam tube reduction, one mountable and one welded HOM coupler, main power coupler flange and pick-up antenna flange.

CAVITY FABRICATION

In a collaboration of FZD and JLab, the fabrication, surface treatment, cleaning, and vertical testing will be performed at JLab. Two new SRF gun cavities are being produced, one made of standard small grain, and one made of large grain Nb. Fig. 7 presents a photograph showing the fabrication status. The surface treatment will be performed with BCP, but we hope that the large grain material [11] helps increasing the performance.



Figure 7: Photograph showing the status of the cavity fabrication.

REFERENCES

- [1] H. Chaloupka, et al., Nucl. Instr. and Meth. A285 (1989) 327.
- [2] A. Michalke, et al., EPAC92, 24-28 March 1992, Berlin, Germany, p. 1014.
- [3] E. Barthels, et al., Nucl. Instr. and Meth. A 445 (2000) 408.
- [4] D. Janssen, et al., Nucl. Instr and Meth. A 507 (2003) 314.
- [5] J. Teichert, et al., EPAC08, June 23-27, 2008, Genoa, Italy, p. 2755.
- [6] A. Arnold, et al., Nucl. Instr and Meth. A 577 (2007) 440.
- [7] K. Zapfe, SRF03, Sept. 8-12, 2003, Travemuende, Germany.
- [8] A. Arnold, et al. Nucl. Instr and Meth. A 593 (2008) 57.
- [9] A. Arnold, et al. PESP workshop, Oct. 1-3, 2008, Newport News, USA.
- [10] V. Volkov and D. Janssen, Phys Rev. ST AB 11 (2008) 061302.
- [11] P. Kneisel, et al., EPAC08, June 23-27, 2008, Genoa, Italy, p. 877.