



Large Hadron Collider Project

LHC Project Report 1165

LHC TRANSVERSE FEEDBACK SYSTEM: FIRST RESULTS OF COMMISSIONING

E.V. Gorbachev, N.I. Lebedev, A.A. Makarov, N.V. Pilyar,
S.V. Rabtsun, R.A. Smolkov, V.M. Zhabitsky^a, JINR, Dubna, Russia
P. Baudrenghien, W. Höfle, F. Killing, I. Kojevnikov, G. Kotzian, R. Louwerse, E. Montesinos,
V. Rossi, M. Schokker, E. Thepenier, D. Valuch, CERN, Geneva, Switzerland

Abstract

A powerful transverse feedback system (“Damper”) has been installed in LHC. It will stabilise the high intensity beam against coupled bunch transverse instabilities in a frequency range from 3 kHz to 20 MHz and at the same time damp injection oscillations originating from steering errors and injection kicker ripple. The LHC Damper can also be used as means of exciting transverse oscillations for the purposes of abort gap cleaning and tune measurement. The LHC Damper includes 4 feedback systems on 2 circulating beams (in other words one feedback system per beam and plane). Every feedback system consists of 4 electrostatic kickers, 4 push-pull wide band power amplifiers, 8 preamplifiers, two digital processing units and 2 beam position monitors with low-level electronics. The power and low-level subsystem layout is described along with first results from the commissioning of 16 power amplifiers and 16 electrostatic kickers located in the LHC tunnel. The achieved performance is compared with earlier predictions and requirements for injection damping and instability control. Requirements and first measurements of the performance of the power and low-level subsystems are summarized.

CERN - AB Department
CH - 1211 Geneva 23
Switzerland

Geneva, November 2008

Presented at the XXI Russian Particle Accelerators Conference
RuPAC 2008
28.09 – 03.10.2008, Zvenigorod

LHC-PROJECT-REPORT-1165
28 Sep 2008



LHC TRANSVERSE FEEDBACK SYSTEM: FIRST RESULTS OF COMMISSIONING

E.V. Gorbachev, N.I. Lebedev, A.A. Makarov, N.V. Pilyar,
S.V. Rabtsun, R.A. Smolkov, V.M. Zhabitsky*, JINR, Dubna, Russia
P. Baudrenghien, W. Höfle, F. Killing, I. Kojevnikov, G. Kotzian, R. Louwerse, E. Montesinos,
V. Rossi, M. Schokker, E. Thepenier, D. Valuch, CERN, Geneva, Switzerland

Abstract

A powerful transverse feedback system (“Damper”) has been installed in LHC. It will stabilise the high intensity beam against coupled bunch transverse instabilities in a frequency range from 3 kHz to 20 MHz and at the same time damp injection oscillations originating from steering errors and injection kicker ripple. The LHC Damper can also be used as means of exciting transverse oscillations for the purposes of abort gap cleaning and tune measurement. The LHC Damper includes 4 feedback systems on 2 circulating beams (in other words one feedback system per beam and plane). Every feedback system consists of 4 electrostatic kickers, 4 push-pull wide band power amplifiers, 8 preamplifiers, two digital processing units and 2 beam position monitors with low-level electronics. The power and low-level subsystem layout is described along with first results from the commissioning of 16 power amplifiers and 16 electrostatic kickers located in the LHC tunnel. The achieved performance is compared with earlier predictions and requirements for injection damping and instability control. Requirements and first measurements of the performance of the power and low-level subsystems are summarized.

INTRODUCTION

The powerful transverse feedback system (“Damper”) for the Large Hadron Collider (LHC) is a joint project of the European Organization for Nuclear Research (CERN) and the Joint Institute for Nuclear Research (JINR) [1]. To a large extent this project is based on the system in the SPS [2] which has operated successfully for many years, facing in recent years, the additional challenge from the electron cloud effect [3].

The LHC will provide high intensity proton and lead ion beams. The ultimate intensities after injection into the LHC will be about $4.8 \cdot 10^{14}$ particles for the proton beam with an energy of 450 GeV and $4.1 \cdot 10^{10}$ ions for the $^{208}\text{Pb}^{82+}$ beam with an energy of 177 GeV/u. These intensities can lead to coherent transverse instabilities. The theoretical prediction for the instability rise time τ_{inst} , dominated by the resistive wall effect, is about 18.5 ms or 208 turns [4] at injection energy, and a significant contribution of the LHC collimators at collision energy to τ_{inst} is also predicted [5]. The LHC Damper will stabilize the beam against coupled

bunch instabilities as well as damp the transverse oscillations of the beam originating from steering errors and kicker ripple. It will also be used for the purposes of tune measurement similar to the SPS system [6] and for abort gap cleaning [7].

GENERAL DESCRIPTION

The LHC Damper has 4 independent transverse feedback systems on 2 circulating beams (one feedback system per beam and transverse plane). Each system is a classical bunch-by-bunch transverse feedback system (TFS, see Fig. 1) [8]. It consists of 2 pick-ups (PU), a 4 section damper kicker (DK) and an electronic feedback path with appropriate signal processing and transmission from PU to DK. The DK corrects the transverse momentum of a bunch in proportion to its displacement from the closed orbit at the PU location. The digital signal processing unit (DSPU) ensures the adjustment of the phase advance and the correction of the time of flight for optimum damping. The mixing of signals from 2 pick-ups allows adjustment of the betatron oscillation phase advance ψ_{pk} from the “virtual” PU to the DK to an odd multiple of $\pi/2$. The total delay τ_{delay} in the signal processing of the feedback path from PU to DK adjusts the timing of the signal to match the bunch arrival time. It equals τ_{pk} , the particle flight of time from PU to DK, plus an additional delay of q turns:

$$\tau_{\text{delay}} = \tau_{\text{pk}} + qT_{\text{rev}}, \quad (1)$$

where T_{rev} is the revolution period of a particle in the synchrotron. The PU and DK are installed at locations with high β -functions. For vertical oscillations in the LHC (see Fig. 1), the delay τ_{delay} is slightly *shorter* than one beam revolution period $T_{\text{rev}} = 88.93 \mu\text{s}$ and $q_v = 0$. For the horizontal systems, kicker *downstream* of the PU, an additional delay of one turn ($q_h = 1$) is added. The delay τ_{delay} is then slightly *longer* than one turn.

The damping time $\tau_d = 40 T_{\text{rev}}$ of the LHC feedback was chosen to limit the emittance growth due to injection errors [9, 10]:

$$\frac{\Delta\epsilon}{\epsilon} = \frac{e_{\text{inj}}^2}{2\sigma^2} F_\epsilon; \quad F_\epsilon = \left(1 + \frac{\tau_{\text{dec}}}{\tau_d} - \frac{\tau_{\text{dec}}}{\tau_{\text{inst}}}\right)^{-2}, \quad (2)$$

where σ is the initial RMS beam size; $e_{\text{inj}} \lesssim 4 \text{ mm} = 3.5\sigma$ at $\beta = 185 \text{ m}$ is the maximum assumed amplitude of a beam deviation from the closed orbit due to displacement

* V.Zhabitsky@jinr.ru

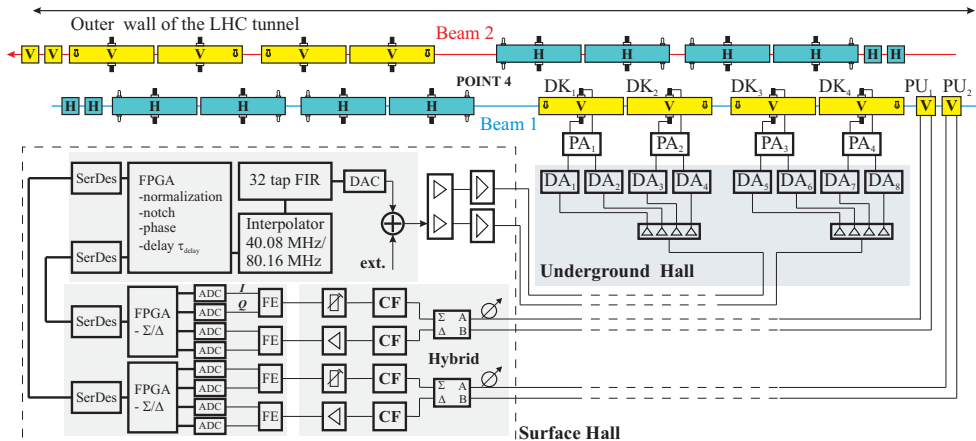

Figure 1: Layout of the LHC Damper and block diagram of the transverse feedback system for vertical oscillations.

and angular errors at injection; $\tau_{\text{dec}} \simeq 750 T_{\text{rev}} = 68$ ms is the assumed decoherence time. These parameters lead to $\Delta\epsilon/\epsilon < 2.5\%$ the maximum admissible emittance blow-up in the LHC allocated to injection dipole errors [4]. Thus, the LHC TFS gain is $g = 2T_{\text{rev}}/\tau_{\text{d}} = 0.05$ and the overall damping time $1/\tau_{\text{d}} - 1/\tau_{\text{inst}}$ of the injection oscillations becomes about 50 turns or 4.4 ms.

The gain g and the maximum injection error e_{inj} yield the maximum deflection $\theta_{\text{max}} = 2 \mu\text{rad}$ required for the proton beam with energy 450 GeV and the location of the kickers at $\beta_k \gtrsim 100$ m. The deflection θ_{max} is delivered by a set of electrostatic kickers with an aperture of 52 mm. The total required deflecting length of 6 m is divided into 4 kickers to limit the capacitive loading of the power amplifiers. The nominal voltage up to 1 MHz is $V_{\text{max}} \pm 7.5$ kV.

The main instability that the feedback has to handle is the resistive wall instability for which the lowest frequency in the LHC is about 8 kHz ($Q_{\text{H}} = 64.28$ and $Q_{\text{V}} = 59.31$). For purposes of abort gap cleaning the unwanted beam should be coherently excited at frequencies (in accordance with the non-integer parts of the tune) gated in the $3 \mu\text{s}$ long abort gap. Consequently a lower cut-off frequency of 1 kHz was chosen for the feedback loop. The highest frequency must be sufficient to damp the dipole mode oscillation of two neighbouring bunches which corresponds to $f_{\text{max}} = 20$ MHz for the nominal bunch spacing of 25 ns. Coherent oscillations at higher frequencies are assumed to be suppressed by Landau damping. The pulse response must cope with the minimum gap between batches in the LHC (995 ns). Consequently, a rise time (1–99% V_{max}) of 720 ns was chosen for the power amplifier.

FEEDBACK LOOP

The feedback loop contains all functionalities for transverse damping and controlled bunch excitation as well as many built-in features allowing the user full remote operation and diagnostics.

Two 50Ω strip-line pick-ups ($f_{\text{centre}} = 500$ MHz) [11] are used to detect the betatron oscillations (see Fig. 1).

Signals from each PU are transmitted by coaxial lines (570–650 m, 7/8" coaxial cable) to the surface hall where after delay calibration (by a cable delay of $\lesssim 5$ ns and a mechanically tuneable fine delay of $\lesssim 2.7$ ns) signals are combined and subtracted by a wideband hybrid (~ 1 GHz) providing Σ and Δ signals. Strip-line comb filters (CF) designed at CERN generate wavelets at 400.8 MHz lasting for 9 RF periods which are then passed to variable attenuators or low noise amplifiers according to the signal levels.

The signals are then processed by the first VME module, the Beam Position Unit (BPU) [12]. Its RF front-end (FE) converts the Σ and Δ signals to the I (In-phase) and Q (Quadrature phase) baseband signals (I/Q demodulator at 400.8 MHz reference clock and Gaussian type low-pass filter with a cut-off of $f_c \simeq 40$ MHz). I and Q signals are digitized (16 bit ADCs) using a 40.08 MHz beam-synchronous clock needed for 20 MHz feedback bandwidth. The digitized I and Q values of the Σ and Δ signals are used to compute for each bunch the normalised transverse beam position Δ/Σ at 40 MS/s rate on a FPGA (field-programmable gate array) semiconductor device.

The normalised position signal is serialized (SerDes) and transmitted via a 1 Gbps serial link to the second VME module, the Digital Signal Processing Unit (DSPU) [13]. After the deserializer (SerDes) the data stream is processed by an FPGA clocked at 40.08 MHz with the following functionalities:

- normalization of signals proportional to $\sqrt{\beta}$ at the corresponding PU locations,
- closed orbit rejection (notch filter),
- phase adjustment by mixing of PU signals to obtain the “virtual” pick-up signal,
- delay (with 10 ps resolution).

A faster clock rate of 80.16 MHz is used for the further processing. The data at the 80.16 MHz sampling rate is obtained from expanding the 40.08 MHz data stream by inserting zeros between the original samples and applying an interpolating FIR filter. A second, 32 tap FIR filter, is then used to compensate the power amplifier phase response, to

optimise the feedback gain for injection error damping and instability control as well as to shape the roll-off beyond 20 MHz. Overall loop gain adjustment is provided via the reference to the 14 bit DAC.

Two output analog signals from a splitter after the DAC are passed to 1 W predriver amplifiers, are then transmitted via coaxial lines (~ 300 m) to the underground hall in a cavern outside of the LHC ring where the signal is again amplified and split to drive the eight 200 W driver amplifiers (DA). The signals are finally transmitted to the 4 power amplifiers (PA) and 4 kickers (DK) located in the LHC tunnel.

RF POWER SYSTEM

The RF power system of the LHC Damper was designed at JINR in collaboration with CERN. The wideband power amplifiers and electrostatic kickers were made by Russian industry and JINR. Final assembly and tests of the amplifiers and kickers were done at CERN.

Electrostatic Kickers

The electrostatic kicker [1] consists of: a) a vacuum tank of stainless steel 304L, 1.6 m length, $\varnothing 100$ mm internal diameter and 14 mm wall thickness for optimal shielding of electromagnetic fields at low frequency and for mechanical stability; b) an electrode module with two electrodes (shaped from copper strips as 90° arcs) and 3 ceramic-metal rings (metallization by a thin layer of rhenium to evacuate any charges) to hold the electrodes and align of the electrode module inside the vacuum tank; c) two high voltage feedthroughs; d) two couplers capacitively coupled to the electrodes to damp high order modes which can be excited by the beam and lead to instability.

The estimated power loss to each electrode from circulating ultimate LHC beam current is ~ 2 W/m. Tests under vacuum have shown that the temperature reaches 70°C when the electrodes are heated with 10 W/m [1]. This allows considerable margin for additional heat loss due to electron cloud.

Tests of the kickers confirmed their compliance with design specifications. Tolerances on the 100 mm tank internal diameter are in the range of $0 \dots +0.054$ mm, camming actions of main flanges ($\varnothing 152$ mm) do not exceed 0.016 mm, the internal surface smoothness obtained is $R_a = 0.4 \mu\text{m}$.

Standard vacuum cleaning procedures were used with a bake-out limited to $< 200^\circ\text{C}$ due to the copper electrodes. The pressure limits ($S = 30 \ell/\text{s}$ for hydrogen) range from $2 \cdot 10^{-10}$ Torr to $1.7 \cdot 10^{-9}$ Torr for the eight installed kicker modules. These results are better than expectations based on an outgasing rate of $4 \cdot 10^{-12} \text{mbar} \cdot \ell/\text{s}$ and a surface area estimated at $2 \cdot 10^4 \text{cm}^2$, with an expected limit pressure of $2.6 \cdot 10^{-9}$ Torr.

NEG pumps [14] are used around the kickers in the LHC tunnel. During hardware and beam commissioning the vacuum at the kickers was better than 10^{-11} mbar.

Power and Driver Amplifiers

16 power amplifiers (PA) are installed directly under the 16 electrostatic kickers (DK) (see Fig. 2) in the LHC tunnel on either side of Point 4 (see Fig. 1). Each pair of electrodes

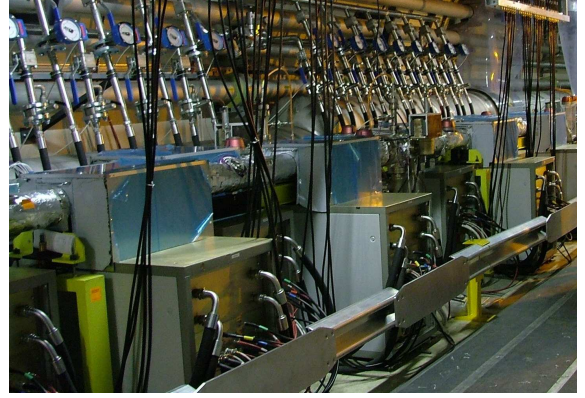

Figure 2: Kickers and amplifiers in the LHC tunnel.

is driven in counter phase by one wideband power amplifier, consisting of two 30 kW grounded cathode tetrodes RS-2048-CJC (Thales®) operated in class AB (push-pull). At low frequency the amplifier works on a relatively large impedance ($\sim 1 \text{k}\Omega$) leading to a large kick voltage. At higher frequency the capacitance of the kicker plates shunts the impedance and consequently less kick strength is available. Simulations of possible variants of the power amplifier electrical circuit were made using MicroSim® PSpice® software [15].

Every power amplifier is driven by two solid state 200 W driver amplifiers (Thales®) operating in class A. Therefore, a total of 32 driver amplifiers are employed in the LHC Damper.

HARDWARE COMMISSIONING

Beam stability is achieved for a damping rate

$$\frac{T_{\text{rev}}}{\tau_{\text{d}}} = \frac{1}{2} g(\omega) \cos(\varphi(\omega)) > \frac{T_{\text{rev}}}{\tau_{\text{inst}}},$$

where $g(\omega)$ and $\varphi(\omega)$ are gain and phase transfer characteristics of the feedback loop. Due to the LHC specifications, the gain transfer function of the feedback loop is constant starting from 1 kHz and decreases by 3 dB at 1 MHz.

The maximum gain of the power amplifier $g_a(\omega)$ has been measured to be between 39 dB with an RF voltage divider sensing the tetrode anode RF voltage. The higher order mode couplers (HOM) can also be used to measure accurately the voltage at the kicker plates and spectrum of this signal $g_h(\omega)$. The HOM couplers consist of a 50Ω vacuum feedthrough with a small plate attached that capacitively couples to the kicker deflecting plates. The coupling capacitance of 6.4 pF and the 50Ω loading at the HOM form a high pass with a cut-off of $f_{\text{HP}} = 500$ MHz. The transfer function from kicker voltage to the voltage

measured at the HOM port when loaded with 50Ω is $\tilde{F} = jf/f_{\text{HP}}/(1 + jf/f_{\text{HP}})$. The spectrum of voltage on the kicker plate is

$$g(\omega) \exp(j\varphi(\omega)) = g_{\text{H}}(\omega) \exp(j\varphi_{\text{H}}(\omega))/\tilde{F}. \quad (3)$$

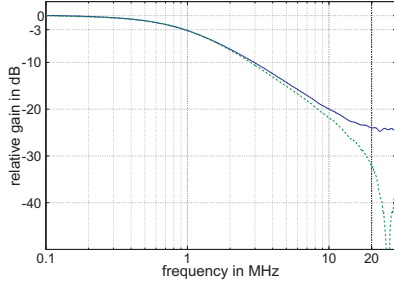

Figure 3: Power amplifier frequency characteristics: roll-off of gain $g(\omega)$ for kicker voltage (solid) and tetrode anode voltage (dashed) $g_{\text{a}}(\omega)$.

Fig. 3 shows the relative gain g_{a} versus frequency measured at the anode of the tetrode (dashed) and at the HOM port, corrected for the high pass response (solid). The latter represents $g(\omega)$ or the voltage seen by the beam as a function of frequency. At the anode of the tetrode the gain characteristics exhibit a resonance at ~ 25 MHz caused by the inductance of the connection to the kicker and the kicker capacitance. This resonance (notch in gain curve) is not seen on the kicker voltage transfer function $g(\omega)$.

The resonance frequencies of the kicker structures in the vacuum chamber were calculated using the computer code MAFIA[®]. A beam travelling along the axis of the structure sees a longitudinal impedance characterized by the usual shunt impedance R_{s} and the quality factor Q . From MAFIA calculations we obtained a ratio of shunt impedance to quality factor R_{s}/Q of approximately $\simeq 2 - 3$ Ohm for each of the first two modes at 89 MHz and 176 MHz. The quality factor of these modes can be reduced by the external load on the HOM port. From measurements on a prototype kicker we obtained a damped quality factor of $Q_1 = 256$ and $Q_2 = 110$ for the first two longitudinal modes [4].

The measured phase response $\varphi(\omega)$ using the HOM ports and correcting for the high pass characteristics is shown in Fig. 4 together with the phase response $\varphi_{\text{a}}(\omega)$ as measured at the anode of the tetrode. Below 3 MHz the phase responses measured via the HOM ports and on the anode voltage dividers perfectly match. The mismatch above 3 MHz is again caused by the resonance. The phase response will be compensated by FIR filters in the digital signal processing unit by adding phase at higher frequency in order to achieve an overall linear phase and constant group delay [13].

The performance specifications and obtained parameters of the power amplifiers in conjunction with the driver amplifiers are shown in Tab. 1.

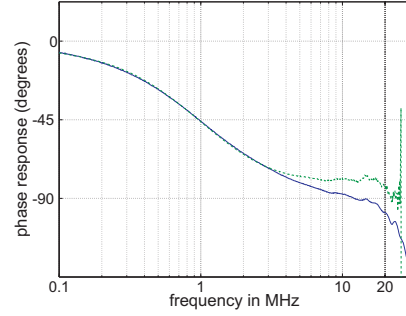

Figure 4: Phase response of power amplifier kicker ensemble, kicker voltage (solid), tetrode anode voltage (dashed).

Table 1: Parameters of amplifiers

Parameter	Required	Achieved
nominal voltage up to 1 MHz	± 7.5 kV	± 7.8 kV
nominal -3 dB bandwidth, kHz	3–1000	2–950
rise-time 10–90% V_{max}	350 ns	410 ns
rise-time 1–99% V_{max}	720 ns	760 ns
gain ripple	0.7 dB	0.5 dB

Power amplifiers and kickers were extensively tested in the run-up for beam commissioning. The design specifications have all been met, the available peak voltage of 11 kV at up to 100 kHz has exceeded the design value 10.5 kV.

FIRST RESULTS OF BEAM COMMISSIONING

The LHC Damper kickers at Point 4 were passed by beam 1 in ring 1 of the LHC on 7th September 2008 and by beam 2 in ring 2 on 10th September 2008. Signals from the LHC Damper pick-up for the first shot of beam 2 (about $2 \cdot 10^9$ protons in a single bunch) are shown in Fig. 5.

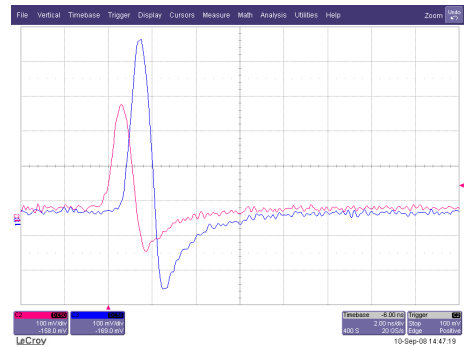

Figure 5: Signals from the LHC Damper pick-up for the first shot of beam 2. 10th September 2008.

Tune measurements [16] were the first operational task for the LHC Damper when it was used as an exciter

after obtaining captured and circulating beam 2 on the 11th September 2008. The tune measurement system uses

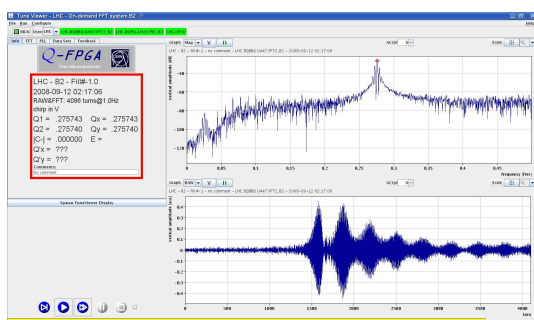

Figure 6: A Tune Measurement using “Chirp” Excitation (courtesy of the AB/BI Group). The bottom trace shows the vertical beam response and the top trace is the spectrum of the signal with the vertical tune peak.

a direct input to the amplifiers in the tunnel to provide a swept frequency sinusoidal excitation to the beam. Fig. 6 shows the results of such a scan, with the applied amplitude of the wideband power amplifiers at only 10% of their maximum.

For damping of single bunch oscillations a special programming has been developed that holds the transverse position value in FPGA memory for one machine turn in order to produce a long output pulse that renders the set-up of the delays easy and operates the power amplifiers in the easier low frequency range up to 1 MHz. The LHC Damper is ready for commissioning with beam.

CONCLUSIONS

The hardware commissioning of the LHC transverse damper system has been successfully completed. The design specifications were all met and the system has been successfully used with first beam in September 2008, exciting transverse oscillations for the purpose of tune measurement. The commissioning with beam for the damping of transverse oscillations has started, pick-up signals verified and the low-level modules set-up for closing the feedback loop. Full operation is planned for the 2009 LHC run.

ACKNOWLEDGMENTS

The authors thank T. Linnecar and E. Ciapala (CERN) for the helpful assistance and support for the project and the many colleagues of CERN and JINR groups, in particular for vacuum, survey and installation.

REFERENCES

- [1] E. Gorbachev et al. “Transverse Damping Systems for the Future CERN LHC”. Proceedings of the 2001 Particle Accelerator Conference, 18 – 22 June 2001, Chicago, USA, pp. 1237–1239. IEEE, 2001.
- [2] R. Bossart et al. “The Damper for the Transverse Instabilities of the SPS”. Proceedings of the 1979 Particle Accelerator Conference, 12 – 14 March 1979, San Francisco, CA, USA, volume NS-26, No.3, pp. 3284–3286. IEEE Transaction on Nuclear Science, 1979.
- [3] W. Höfle. “Progress with the SPS Damper”. Proceedings of Chamonix XI, January 2001, pp. 117–124. CERN, Geneva, 2001.
- [4] O.S. Brüning et al. The LHC Design Report. Vol. 1. CERN-2004-003, CERN, Geneva, 2004.
- [5] E. Métral et al. “Transverse Impedance of LHC Collimators”. Proceedings of the 2007 Particle Accelerator Conference, 25 – 29 June 2007, Albuquerque, New Mexico, USA, pp. 2003–2005. IEEE, 2007.
- [6] R. Bossart and V. Rossi. “Coherent excitation of vertical beam oscillations”. SPS Improvement Report No.156, CERN-SPS-ABM-RB-jf, CERN, Geneva, 29 January 1979.
- [7] A. Koschik et al. “Abort Gap Cleaning Using the Transverse Feedback System: Simulation and Measurements in the SPS for the LHC Beam Dump System”. Proceedings of the 11th European Particle Accelerator Conference, 23–27 June 2008, Genoa, Italy, pp. 2656–2658. Institute of Physics, 2008.
- [8] L. Vos. “Damping of Coherent Oscillations”. NIM A, 391, pp. 56–63, 1997. CERN-SL-96-066-AP, Geneva, CERN, December 1996.
- [9] L. Vos. “Transverse Emittance Blow-up from Double Errors in Proton Machines”. Proceedings of the Sixth European Particle Accelerator Conference, 22–26 June 1998, Stockholm, Sweden, pp. 1365–1367. Institute of Physics, 1998.
- [10] V.M. Zhabitsky. “Transverse Emittance Blow-Up from Beam Injection Errors in Synchrotrons with Nonlinear Feedback Systems”. Physics of Particles and Nuclei Letters, vol. 5, No.1(143), pp. 49–53, 2008.
- [11] E. Calvo-Giraldo et al. “The LHC Orbit and Trajectory System”. CERN-AB-2003-057 BDI, CERN, Geneva, 19 June 2003.
- [12] D. Valuch and P. Baudrenghien. “Beam phase measurement and transverse position measurement module for the LHC”. LLRF07 Workshop. Knoxville TN, USA, October 2007. https://edms.cern.ch/file/929563/1/llrf07_poster.pdf.
- [13] P. Baudrenghien, W. Höfle, G. Kotzian, and V. Rossi. “Digital Signal Processing for the Multi-bunch LHC Transverse Feedback System”. Proceedings of the 11th European Particle Accelerator Conference, 23–27 June 2008, Genoa, Italy, pp. 3269–3271. Institute of Physics, 2008.
- [14] J.M. Jimenez. “LHC: The World’s Largest Vacuum Systems being Commissioned at CERN”. Proceedings of the 11th European Particle Accelerator Conference, 23–27 June 2008, Genoa, Italy, pp. 1959–1961. Institute of Physics, 2008.
- [15] E. Gorbachev, V. Melnikov, and W. Höfle. “Computer simulation of the electrical circuit of the wideband power amplifier for the transverse damping system of LHC”. LHC Project Note 259, CERN, Geneva, June 2001.
- [16] M. Gasior and R. Jones. “The Principle and First Results of Betatron Tune Measurement by Direct Diode Detection”. LHC-Project-Report 853, CERN, Geneva, August 2005.