

RF INPUT COUPLERS AND WINDOWS: PERFORMANCES, LIMITATIONS, AND RECENT DEVELOPMENTS

MARK S. CHAMPION

*Fermi National Accelerator Laboratory, Wilson & Kirk Roads,
Batavia, Illinois 60510, USA*

(Received 24 January 1996; in final form 24 January 1996)

Radiofrequency input couplers are very important components in particle accelerators which rely on resonant cavities for acceleration, regardless of whether the cavities are superconducting or normal conducting. If not properly designed and implemented, the input couplers can at best delay the completion of an accelerator, and at worst limit the performance of an accelerator such that its design goals are not met. It is useful then to review the performances and limitations of installed RF input couplers, and to examine recent input coupler developments. By doing so we may apply the experiences of our colleagues in designing input couplers for future accelerators.

Keyword: Radio-frequency devices

1 INTRODUCTION

When particle accelerators make use of radiofrequency (RF) cavities, either superconducting or normal conducting, it is often the cavities themselves that receive the most attention. However, the cavities are of little value without RF input couplers, which are usually more difficult to realize than is foreseen. There are many, sometimes conflicting, requirements placed on the couplers. Some of these are as follows:

- no multipacting
- tolerance to X-rays and high energy particles
- high power capability for gradient regulation, cavity conditioning, and energy upgrade potential

- adjustable coupling to accommodate cavity/coupler variations and changing beam current requirements
- mechanical rigidity to minimize vibrational effects
- mechanical flexibility to accommodate shrinkage during cooldown
- one or two vacuum windows, warm or cold, to isolate the cavity vacuum
- low static and dynamic heat load to the cavity and to the cryogenic systems
- extreme cleanliness so as to not contaminate the cavity
- low cost
- maintainability

The fulfillment of these requirements is a demanding task, which requires the concerted efforts of many people, with adequate funding, facilities, and support from management. A guaranteed recipe for success does not exist, but the key ingredients are known. The following sections present first a review of some operating systems, then some results from the high-current machines presently under development, followed by a report on the TESLA Test Facility input couplers, a section on special purpose cavity-test couplers, and finally a conclusion with some recommendations for successful input coupler development.

2 REVIEW OF SOME OPERATING SYSTEMS

2.1 CEBAF Input Couplers

The CEBAF accelerator is a 4 GeV electron five-pass recirculating linear accelerator. It makes use of five-cell 1.5 GHz niobium cavities operating at a temperature of 2 K. There are 338 cavities installed, with two cavities per cryounit. Each cavity is driven by its own klystron, which at this time can produce a maximum of 1.7 kW continuous wave power. A power supply upgrade planned for early 1996 will increase the klystron power to 5 kW. Radiofrequency power is delivered to the cavity by a waveguide input coupler which has a fixed coupling ratio and is mounted on the beam tube adjacent to the first cell. Two waveguide vacuum windows protect the cavity vacuum. The first window is fabricated from high purity aluminum oxide (Al_2O_3) and is mounted only 8 cm distant from the cavity axis. Hence, it is operated at a temperature of 2 K. The second window, which is fabricated from polyethylene, is mounted at room temperature outside of the vacuum vessel. The coupling ratio is fixed. The layout of the two-cavity cryounit is shown in Figure 1.

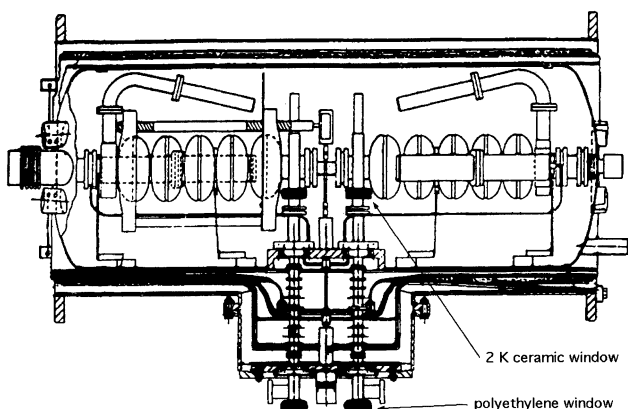

FIGURE 1 The layout of the CEBAF two-cavity cryo-unit.¹

In the absence of field emission, the performance of the CEBAF input coupler is satisfactory. However, in the presence of field emission, the coupler performance is degraded due to charging of the cold window followed by surface flashover. A window arc detector interlock leads to a brief loss of beam when a flashover occurs. The arc rate may be reduced by lowering the accelerating gradient for field emitting cavities. Trajectory calculations have shown that the cold window may be impacted directly by field emitted electrons and by back-scattered electrons.² Experiments in which the window charging current is measured show that not only the cavity on which the window is mounted contributes to the charging effect, but also nearby field emitting cavities.³ Further, it has been shown in vertical dewar tests that increasing the distance between the cold window and the cavity axis significantly reduces the charging effect.⁴ A special cryomodule is being prepared for installation in early 1996 to test the effectiveness of locating the cold windows just inside the helium shield at a distance of approximately 23 cm from the cavity axis.

Phenomena occurring at the cold window are the primary limitations to higher accelerating gradients at CEBAF. At this time, in approximately one third of the cavities, the gradients are limited by window effects. After the klystron upgrade next year, it is expected that nearly all of the cavities will be limited by the cold window. For the cavities now limited, gradient reduction averages 2 MV/m below commissioning limits, which were themselves

generally set by field emission loading.⁵ It should be noted that in spite of the cold window problems, the CEBAF accelerator does meet its performance specifications. Fortunately, recovery from cold window interlock events is very fast. The recovery procedure is now manual and requires a few minutes. Automated recovery routines are expected to reduce the beam interruption time to a few seconds.

2.2 CERN LEP2 Input Couplers

If there is only one lesson to be learned from the experience with the LEP2 input couplers, it is this: Never underestimate the serious dangers of multipacting, even in a simple geometry such as a coaxial line. As will be explained, it was just this problem that proved to be the most severe obstacle for the developers of these input couplers.

The LEP2 upgrade requires the installation of more than 200 superconducting cavities operating at a frequency of 352 MHz. The electron/positron synchrotron is planned to have a beam energy of 90 GeV, which is an increase of 40 GeV over the LEP energy of 50 GeV. Four cavities are installed in each cryomodule. The input couplers are required to transfer 125 kW of continuous wave RF power to the cavities, which are operated at a temperature of 4.5 K. The four-cell cavities are fabricated from copper sheet material, and then sputter coated with niobium on the interior.⁶

The design of the LEP2 input coupler calls for a coaxial coupler with capacitive coupling to the cavity on the beam tube adjacent to the first cell. A room temperature cylindrical Al_2O_3 ceramic window, similar to that used in the coupler for the LEP copper cavities, is incorporated into the waveguide-to-coaxial "doorknob" transition to protect the cavity vacuum. The inner conductor of the coupler is air-cooled, whereas the outer conductor is cooled via cold helium gas. The outer conductor diameter is 103 mm, and the coaxial line has a characteristic impedance of 75 Ω . The inner conductor is electrically isolated from the outer conductor via a cylindrical bypass capacitor incorporated into the waveguide-to-coaxial transition. This allows for the application of a DC bias voltage of 2.5 kV to suppress multipacting in the coaxial line. The coupler features a fixed coupling ratio.

The input coupler performance seems to be satisfactory at this time. However, during the evolution of this coupler there were many difficulties due primarily to multipacting in the coaxial line. This evolution will be

described, and is covered in more detail by Tückmantel *et al.*⁷ The design for this coupler initially called for a 103 mm, 50 Ω coaxial line with fixed coupling. Later it was decided to incorporate a 25 Ω choke section into the waveguide-to-coaxial transition so as to provide variable coupling. High power RF tests of these couplers on a test stand indicated that they performed adequately after conditioning. However, tests on cold cavities showed deconditioning of the input couplers after operating for a short time. Reconditioning enabled the recovery of normal operation, but it was not long lasting.

Calculations showed that single-point multipacting on the outer conductor of the 50 Ω line and two-point multipacting in the 25 Ω choke section were responsible for the operational difficulties. Two major changes in the coupler design resulted from the multipacting findings: the choke section which allowed for variable coupling was abandoned, and the coaxial line impedance was changed to 75 Ω by reducing the diameter of the inner conductor. The first change eliminated the multipacting levels in the 25 Ω choke section, and the second change shifted the remaining multipacting levels up in power by 50%.

Because the multipacting was occurring on the outer conductor of the coaxial line, efforts were made to improve its surface. One change was to go to a one-piece forged construction, thus eliminating several welds. The thin layer of copper on the outer conductor has been deposited by both electroplating and by sputtering. It is not clear that one technique is superior to the other in terms of coupler performance. The application of a titanium coating has been attempted in an attempt to reduce the secondary electron coefficient of the copper-plated surface, but did not show improved performance. In fact, the performance was degraded. High pressure water rinsing is applied as a standard technique in the preparation of the outer conductor.

A pair of input couplers with an eccentric inner conductor were constructed to test the idea that the multipacting would concentrate on the wide gap, and that the conditioning would be simplified due to the smaller surface area involved. The performance of these couplers showed no improvement over the standard coupler design. Another attempt to prevent multipacting was the introduction of RF drive power on a frequency from 200 kHz to 1 MHz distant from the fundamental frequency. This perturbs the multipacting resonance conditions sufficiently to eliminate the multipacting on the warm coupler test stand, and to significantly reduce the multipacting on a cold cavity. However, a more comprehensive solution was still sought.

The addition of a 2.5 kV DC bias between the inner and outer conductors of the input coupler has provided for the complete suppression of multipacting. This required, however, the development of a non-trivial bypass capacitor, similar to those commonly used in vacuum-tube power amplifier designs. The DC bias is applied only after the multipacting levels in the coupler have been RF conditioned. Application of the bias prior to conditioning leads to damaging discharges in the coupler. Typically, after conditioning on the coupler test stand and installation onto a cavity, the coupler must be reconditioned *in situ* on the cold cavity before switching on the DC bias. Recent tests have shown that baking the ceramic window after installation of the coupler onto the cavity minimizes the necessary *in situ* coupler reconditioning.⁸ Hence, the deconditioning problems seem to be caused by the condensation of gases evolving from the ceramic window onto the cold outer conductor of the input coupler.

2.3 Darmstadt S-DALINAC Input Couplers

The Darmstadt S-DALINAC is a 130 MeV electron three-pass recirculating linear accelerator which uses 3 GHz superconducting niobium cavities at a temperature of 2 K. There are ten 20-cell, one 5-cell, and one 2-cell cavities. One half of a cryomodule for the 20-cell cavities is shown in Figure 2. The installation of the input couplers for these cavities was completed in the Spring of 1995. They replaced the first generation of input couplers, which suffered from various difficulties to be described later.

The input coupler is coaxial and is capacitively coupled to the cavity on the beam tube adjacent to the first cell as shown in Figure 3. An interesting feature of this coupler is that it makes use of an intermediate coaxial resonator, whose outer conductor is the cavity beam tube, and through whose inner conductor the beam passes. This geometry provides for electrical symmetry, and hence generates no transverse forces on the beam. It is also mechanically rigid. Coupling adjustment is possible by adjusting the coupling between the intermediate resonator and the input drive line. A bellows on the outer conductor of the drive line allows for the antenna to be driven toward or away from the intermediate resonator. This provides for variation of more than three orders of magnitude in the external quality factor, Q_{ext} . The coupler features two Al₂O₃ disk-type ceramic windows at 300 K, and a teflon centering disk and dust barrier at 2 K. The maximum required power transmission is 500 W, continuous wave. The performance of these couplers is satisfactory, with no

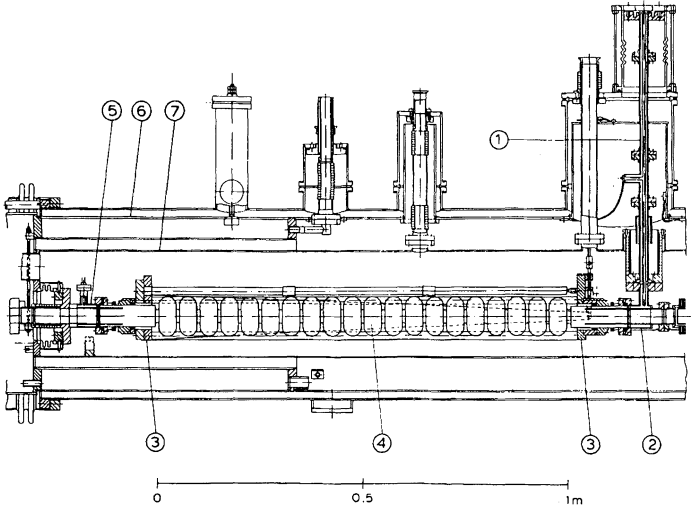

FIGURE 2 One half of the S-DALINAC two-cavity cryomodule.⁹

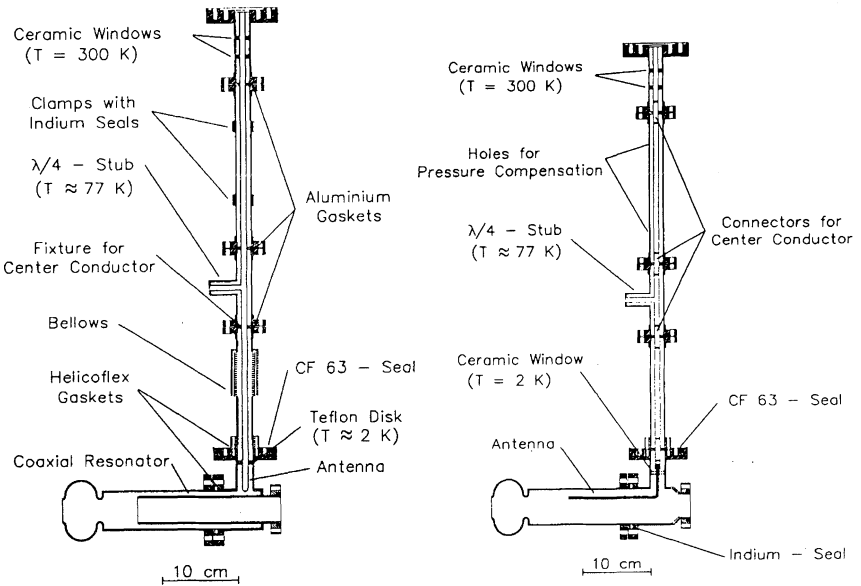

FIGURE 3 The new (left) and the old (right) RF input coupler for the S-DALINAC.⁹

difficulties due to multipacting, heating, or vibrations. However, the same cannot be said of the input couplers which they replaced.

The first generation input couplers at Darmstadt featured an Al_2O_3 disk-type ceramic window at 2 K, instead of the teflon spacer used in the present design. Hence the coupler vacuum, which was in common with the cryostat insulation vacuum, and cavity vacuum were separated. The coupler antenna extended into the beam tube, and then was bent by 90 degrees and continued more than 10 cm toward the first cavity cell as shown in Figure 3. The coupling was not adjustable, and the reproducibility of the coupling ratio was poor due to mechanical tolerance sensitivity. Further, the antenna was prone to mechanical vibrations. Approximately 50% of the 2 K ceramic windows developed vacuum leaks, which led to a mixing of cryostat insulation vacuum and cavity vacuum. This in turn led to degraded cavity performance. These difficulties led to the development and installation of the new input couplers, which are fully described in the thesis of Rietdorf.⁹

2.4 DESY HERA Input Couplers

Sixteen superconducting niobium 4-cell cavities have been operating at 500 MHz in the HERA 30 GeV electron synchrotron since 1991. There are two cavities per cryomodule at a temperature of 4 K. The input coupler¹⁰ for these cavities consists of a waveguide-to-coaxial doorknob transition which incorporates a cylindrical Al_2O_3 vacuum window at room temperature, and a coaxial line which penetrates the vacuum vessel and connects to the cavity beam tube adjacent to the first cell as shown in Figure 4. Coupling to the cavity is capacitive, and the Q_{ext} of the coupler is constant. Small coupling changes can be managed by a triple-stub waveguide tuner upstream of each input coupler. The inner and outer conductors of the coaxial line are cooled with He gas. Forced air cooling is used on the ceramic window. Prior to installation on the cavities, these couplers were conditioned up to a power level of 300 kW continuous wave. At this time, the input couplers are operated up to a maximum of 65 kW continuous wave. This limit is set by the klystron RF system.

There have not been any input coupler failures since the superconducting cavities were commissioned. However, there are recurring difficulties with multipacting. Statistics on the recent operation of HERA indicate that 19% of beam loss is due to the input couplers, with the following reasons:¹¹

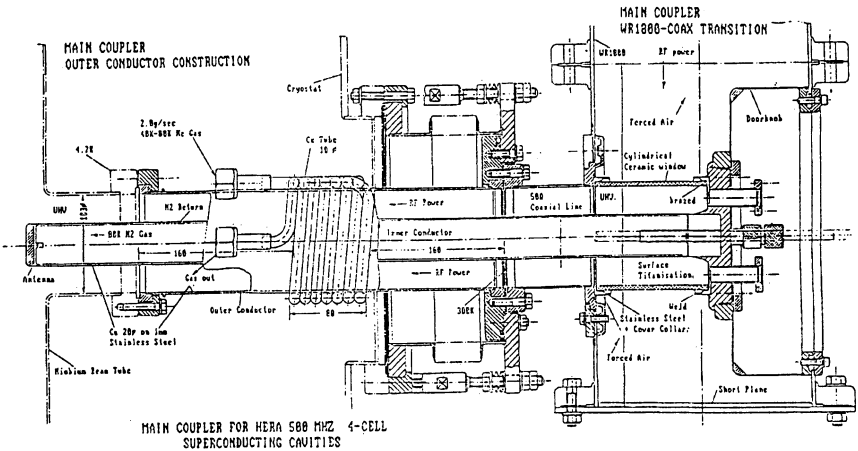

FIGURE 4 The DESY HERA RF input coupler.¹⁰

- multipacting plasma 14%
- ceramic over temperature 3%
- light production in coupler 2%

Periodic *in situ* reconditioning of the input couplers is necessary and is effective in reducing the number of coupler related beam loss events. During reconditioning, the couplers are pulsed with 5 ms pulses while the cavity is slowly tuned about its resonance so as to shift the standing wave pattern in the input coupler. Recently, the couplers have been undergoing reconditioning on a daily basis during no-beam times. The application of a DC bias between the inner and outer conductors is being considered as a way to eliminate the multipacting and the need for frequent reconditioning. Another idea is to change to forced air cooling of the inner conductor, since the recurrence of multipacting is likely due to the accumulation of condensed gases on the surfaces of the input couplers.

2.5 KEK TRISTAN Input Couplers

The TRISTAN machine is a 29 GeV electron/positron synchrotron, whose Main Ring accelerator has made use of superconducting niobium cavities

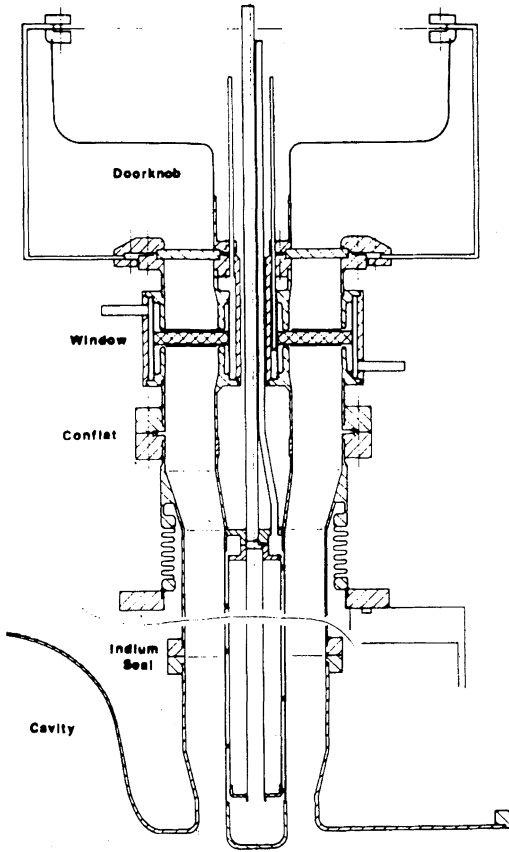

FIGURE 5 The KEK TRISTAN input coupler.¹²

since 1988. There are 32 five-cell cavities operating at 508 MHz at a temperature of 4.4 K. Three more of these cavities are used in the Accumulation Ring. All of these cavities use the same type of input coupler,¹² which consists of a waveguide-to-coaxial doorknob transition, a coaxial teflon spacer, a coaxial disk-type Al_2O_3 ceramic window at 300 K, and coaxial capacitive coupling to the cavity at the beam tube adjacent to the first cell as shown in Figure 5. The coupling ratio is fixed, and water flow is used to cool the inner conductor. The inner conductor is fabricated from thin-wall copper

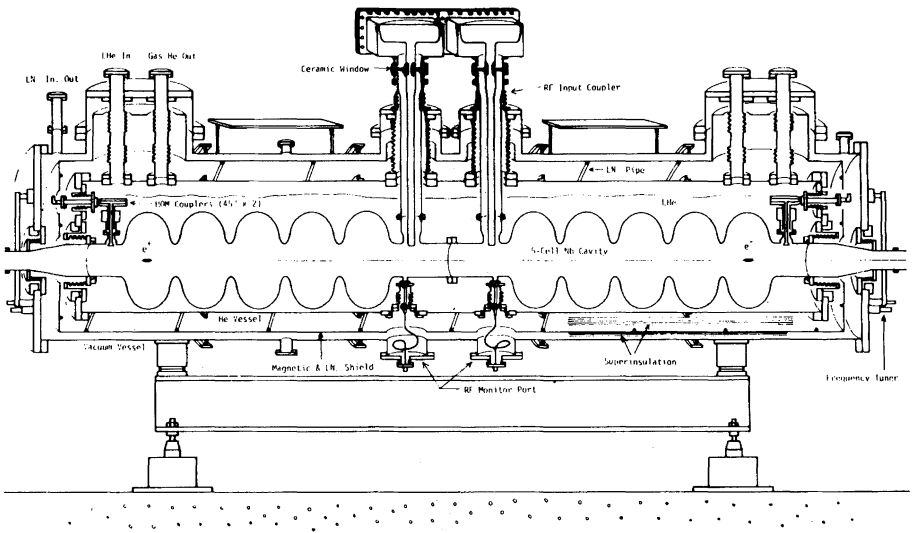

FIGURE 6 The KEK TRISTAN cryostat layout.¹²

tubing, whereas the outer conductor is copper-plated thin-wall stainless steel. The power transmission requirements are 40–70 kW, continuous wave. Prior to installation, the couplers were conditioned up to 200 kW continuous wave on a traveling wave test stand whereby two couplers were processed together. The two-cavity cryostat is depicted in Figure 6.

There have been numerous difficulties with the input couplers since their commissioning. Initially, no anti-multipacting coating was applied to the ceramic window. Multipacting was present during the coupler conditioning, and led to the development of vacuum leaks on four windows during conditioning. The later addition of a 60 Å layer of titanium nitride greatly reduced the conditioning time and the number of arcs during conditioning.

The outer diameter of the ceramic window is enclosed in a water jacket. Three of these water jackets developed water leaks due to cavitation erosion and caused six cavities to be flooded with cooling water in 1991–92. These cavities subsequently received new surface treatment. The solution to this problem was to simply discontinue the water cooling.

Six ceramic windows developed vacuum leaks during operation due to arcs and burning of a polyethylene support disk in the coaxial line between the

ceramic window and the doorknob transition. The addition of a photodiode arc detection system and the replacement of the polyethylene disks by teflon disks has prevented recurrence of this problem.

Although the previously described problems have been solved, the input couplers continue to experience some multipacting, which requires that each coupler be conditioned *in situ* before each cool down of the cavities. More information on operational status and studies are presented by Furuya *et al.*¹³ and Shishido *et al.*¹⁴

3 NEW HIGH-CURRENT MACHINES

3.1 Cornell CESR Phase III

The CESR phase III upgrade at Cornell University calls for the installation of four single-cell niobium cavities operating at a frequency of 500 MHz. Each cavity must transfer 325 kW of continuous wave RF power to the beam for the design current of 1 A to be achieved. The RF input coupler design consists of a superconducting niobium reduced-height WR1800 waveguide coupled to the cavity via an aperture on the beam tube adjacent to the cavity. A waveguide vacuum window is mounted external to the cryostat at room temperature. It is desired that this window withstand up to 500 kW of incident power in traveling wave conditions, and up to 125 kW of incident power in standing wave conditions. Two different windows have been developed and tested.

The first window assembly, provided by Premier Microwave, uses three beryllium oxide (BeO) disks as shown in Figure 7. The disks are mounted in a water-cooled copper frame, and are coated with titanium nitride on the vacuum side. Impedance matching posts on both sides of the window compensate for the discontinuity presented by the BeO disks. Traveling wave tests¹⁵ on two window assemblies connected together with an evacuated region in between showed a maximum continuous wave power capability of 260 kW. Beyond this power level, bursts of outgassing prevented continuous operation. The cause of the gas bursts is thought to be multipacting, but excessive RF heating in the region of standing waves between the BeO disks and the impedance matching posts may also contribute. The standing wave goal of 125 kW incident power was achieved regardless of the window position in the standing wave pattern. Heating of the BeO ceramics was negligible.

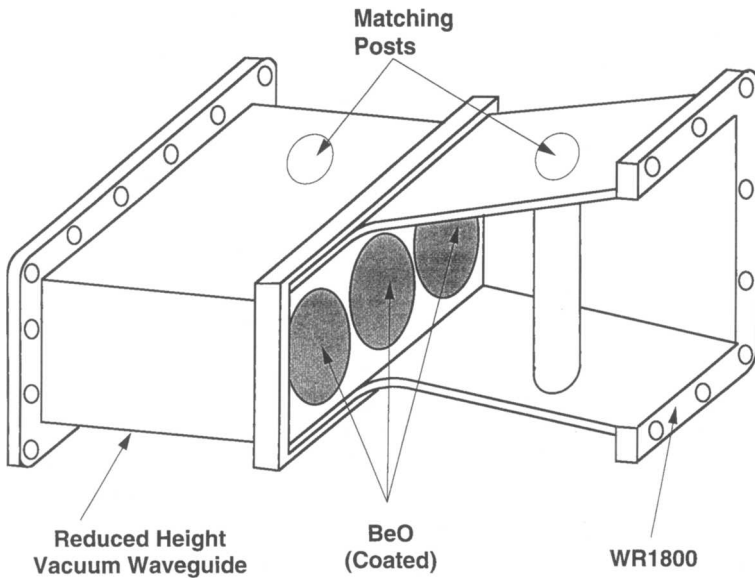

FIGURE 7 The Premier Microwave window (J. Kirchgessner, Cornell).

During a recent beam test, this window assembly performed well enough to support a beam current of 220 mA and a cavity accelerating gradient of 6 MV/m.¹⁶ The maximum RF power delivered through the window to the cavity and the beam was 155 kW. The only limitation imposed by the window assembly was the inability to perform cavity processing to reduce field emission. The window assembly required about 30 hours of conditioning with beam on and the cavity locked on resonance to reach the 155 kW level. The window was vented to clean air for several days between the off-line window tests to 260 kW and the on-line beam test. The cavity beam test configuration is shown in Figure 8.

A second window assembly, provided by Thompson Tubes, uses a single Al_2O_3 ceramic disk as shown in Figure 9. The ceramic is mounted in a water-cooled copper frame, and the vacuum side of the ceramic is coated with titanium nitride. Impedance matching posts are used on both sides of the window. However, the impedance discontinuity that they compensate is much less compared to that for the previously described Premier window.

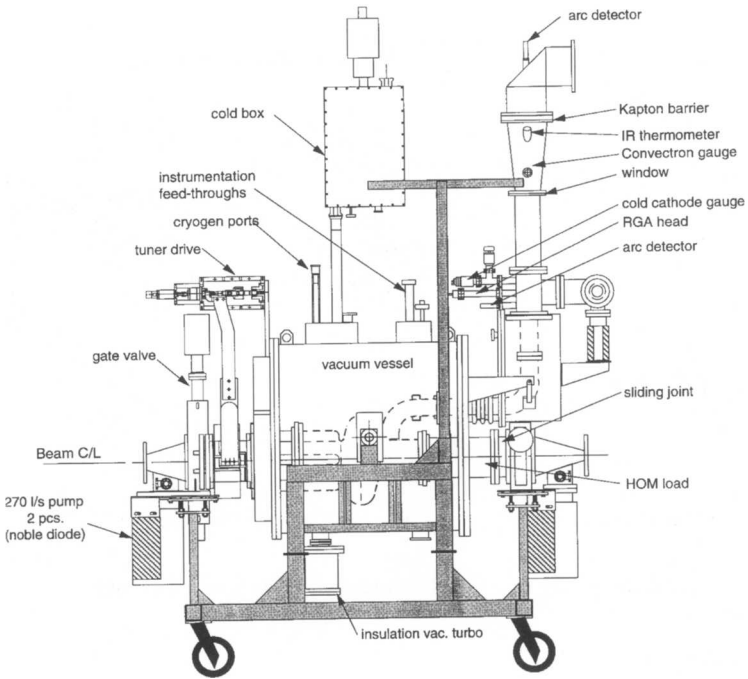

FIGURE 8 The cavity layout for the beam test (J. Kirchgessner, Cornell).

During traveling wave testing of a pair of Thompson windows, continuous wave operation up to 300 kW was achieved.¹⁷ The windows were operated up to 350 kW at a 50% duty factor, and up to 430 kW at a 33% duty factor. The duty factor limitations were due to the klystron used for the testing. The window was successfully tested under standing wave conditions at 125 kW incident power with the window at several different positions in the standing wave pattern. During the high power testing, one of the window ceramics exhibited a temperature differential in excess of 60°C from its center to its outer diameter. This is near the limit specified by the manufacturer.

It is expected that with the addition of forced-air cooling for the ceramic, the Thompson window will meet the needs for the CESR upgrade. A new klystron is being installed so that continuous wave testing to more than 400 kW is possible. It is planned to locate the window at the cavity detuned short position, i.e., at the null of the voltage standing wave pattern that occurs

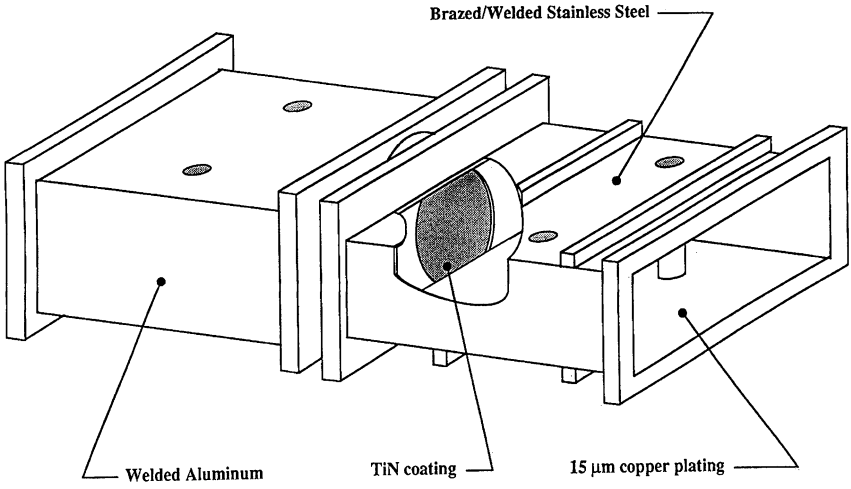

FIGURE 9 The Thompson Tubes window (J. Kirchgessner, Cornell).

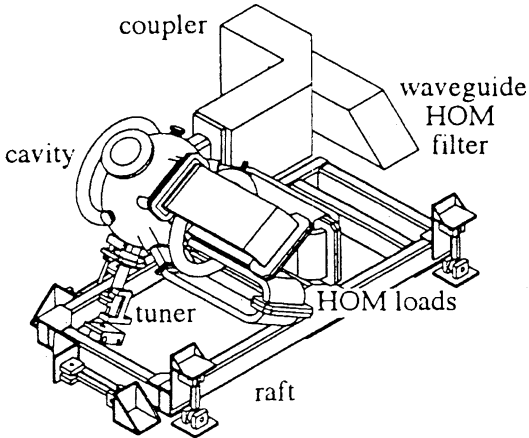

FIGURE 10 The layout of the PEP-II cavity assembly.¹⁸

when the cavity is detuned. This will maximize the power capability for high peak power processing of cavity field emission sites.

3.2 PEP-II B-Factory

The PEP-II B Factory, which is being developed and constructed by SLAC, LBL, and LLNL, will depend on room temperature copper single-cell accelerating cavities operating at a frequency of 476 MHz. The RF input coupler for these cavities is specified to be capable of delivering up to 500 kW of continuous wave power. The input coupler delivers power to the cavity via rectangular waveguide, and makes use of a single waveguide ceramic vacuum window, which is positioned at the cavity detuned short position. The window is located upstream of a waveguide bend, which shields the window from line-of-sight beam exposure. The layout of the cavity, coupler, and associated hardware is shown in Figure 10.

The window design¹⁹ calls for a 254 mm diameter, 18.3 mm thickness Al_2O_3 ceramic disk brazed into a copper-plated stainless steel compression ring. Considerable effort has been put forth to ensure a high quality braze joint which maintains radial compression on the ceramic to counterbalance the stresses induced by RF heating during operation.²⁰ The stainless steel compression ring includes a knife-edge which is machined after brazing. A copper gasket between this ring and the mating knife edge on the waveguide aperture provides the vacuum seal and RF contact.

Two window assemblies were mounted back-to-back and evacuated in between for a high power RF test. Included in the instrumentation were optical viewports that allowed for photo-multiplier tube arc detection and infrared monitoring of the ceramic temperature profile. In a traveling wave test with a 100% duty factor, the windows were limited to 270 kW due to multipacting. The multipacting produced a purple glow on the ceramic surface and caused increased heating of the ceramic. The ceramics are coated with titanium nitride.

After venting the evacuated region between the windows with nitrogen gas, the windows were successfully tested at power levels up to 500 kW. This test confirms multipacting as the source of difficulties during the test under vacuum. There is ongoing work to optimize the titanium nitride coating to eliminate multipacting while keeping the RF dissipation at an acceptable level.

3.3 KEK B-Factory

The KEK B Factory requires two RF input coupler designs, one for the normal conducting cavities and one for the superconducting cavities. Both cavity types require an input coupler capable of delivering 400 kW of continuous wave power at 508 MHz.

The input coupler for the normal conducting cavity is based on the output coupler of the TRISTAN klystron, which transmits up to 1.2 MW of continuous wave power at 508 MHz. This coupler features a disk-type coaxial window as shown in Figure 11. Two variations of the coaxial window have been designed for the B Factory. One is nearly identical to the klystron window, and makes use of a choke-type geometry at the interface between the ceramic and the conductors of the coaxial line. The other design features an undercut/overcut geometry. Both window configurations provide for shielding the ceramic from line-of-sight exposure to the beam, as illustrated in Figure 12. While the choke-type geometry has been proven in the klystron application, it does create enhanced electric fields, normal to the ceramic, in the gap between the ceramic and the rounded tips of the inner and outer conductors. The undercut/overcut geometry does not create field enhancement, and the electric field lines are parallel to the ceramic surface, presumably reducing the risk of multipacting. High power implementations of both designs are in progress at this time. A schematic of the normal conducting cavity system is shown in Figure 13.

The input coupler for the superconducting cavity is nearly identical to the TRISTAN Main Ring coupler described earlier. Recent high power tests have shown this coupler to be capable of transmitting up to 800 kW of continuous wave power. Beam tests are planned with a cavity mounted in a cryomodule as shown in Figure 14.

4 TESLA INPUT COUPLERS

The TESLA Test Facility (TTF) at DESY is a 500 MeV electron linac that is currently under construction at DESY. The basic accelerating unit for TTF is a nine-cell 1.3 GHz niobium cavity operating at a temperature of 1.8 K. Two coaxial input couplers designs, one by Fermilab and the other by DESY, are under development for the TTF. The input couplers will operate with a 1.3 ns pulse length and a repetition rate of 10 Hz. The couplers must transfer more

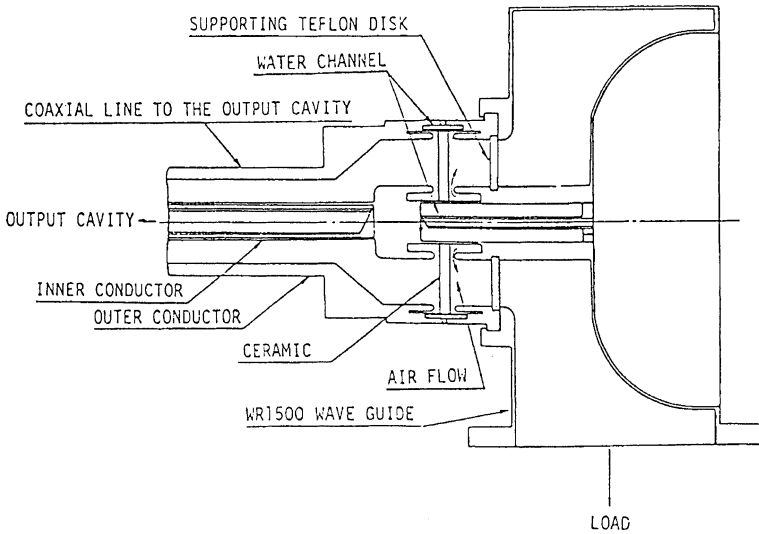

FIGURE 11 The RF output coupler of the TRISTAN 1.2 MW klystron.²¹

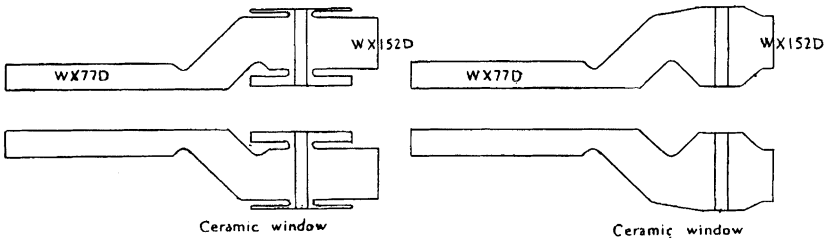

FIGURE 12 The coaxial window designs for the KEK-B normal conducting cavity. The choke-type design is on the left, and the over/under-cut design is on the right.²²

than 200 kW of rf power to the cavities during normal operation, and should be able to accommodate power levels up to approximately 1 MW for *in situ* high peak power processing to reduce cavity field emission. The couplers are specified to have a Q_{ext} of $3e6$, variable from $1e6$ to $1e7$. The input coupler port on the beam tube of the cavity is expected to move up to 15 mm in the direction of the cavity axis during thermal cycles, hence the input couplers must be flexible. The requirement of a ceramic vacuum window near the

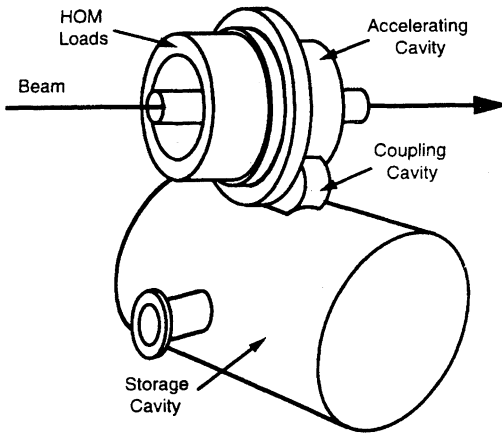

FIGURE 13 The KEKB normal conducting cavity layout.²³

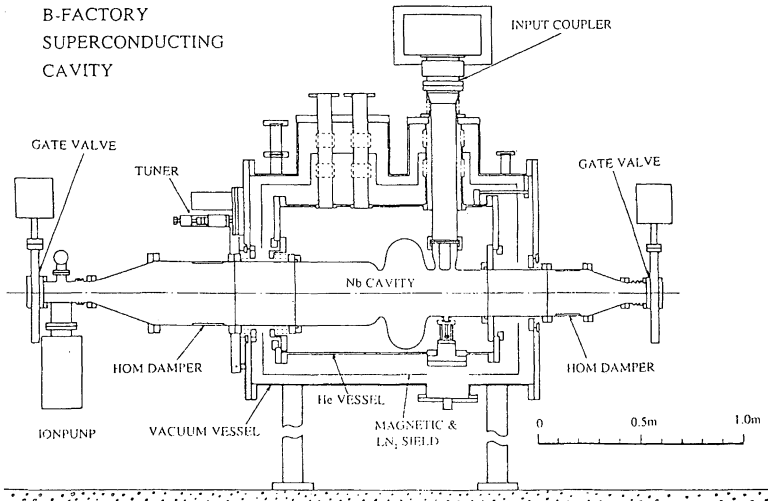

FIGURE 14 The layout of the cryomodule for the KEKB SRF beam test.¹³

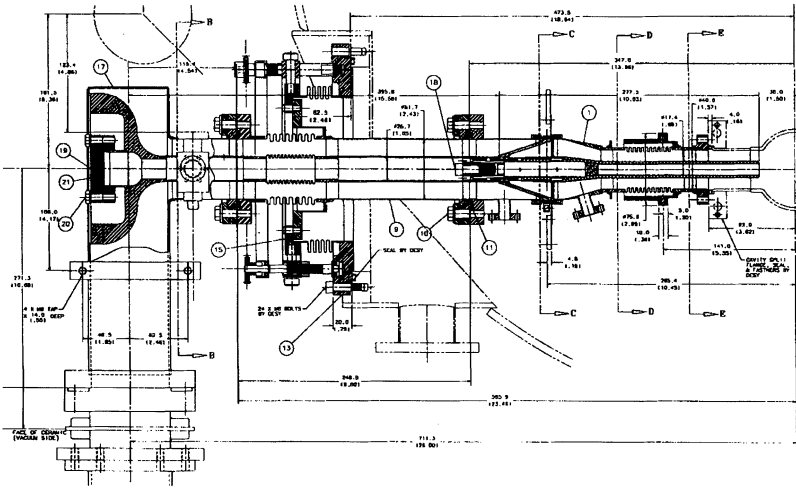

FIGURE 15 The Fermilab design for the TTF input coupler.

cavity at 70 K forces the addition of a second vacuum window at 300 K. The 70 K window is to be installed onto the cavity in a class 10 clean room area. Two heat intercepts will be used, one at 4.5 K near the coupler-to-cavity flange joint, and the other at 70 K near the coaxial vacuum window.

4.1 FERMLAB Input Coupler

The design of the Fermilab input coupler is shown in Figure 15. This coupler features two Al_2O_3 ceramic windows, one a conical coaxial window at 70 K, and the other a planar waveguide window at room temperature. Both windows are positioned at the cavity detuned short position, i.e., they are located at the null of the voltage standing wave pattern that occurs during cavity filling at the beginning of each RF pulse. For the conical window, whose length is electrically nearly a quarter wave, this means that the connection of the ceramic to the inner conductor is at a voltage minimum, whereas the connection to the outer conductor is at a voltage maximum. The windows are coated with a 50–100 Å layer of titanium nitride on their vacuum surfaces. Three hydroformed bellows allow for flexibility and coupling adjustment.

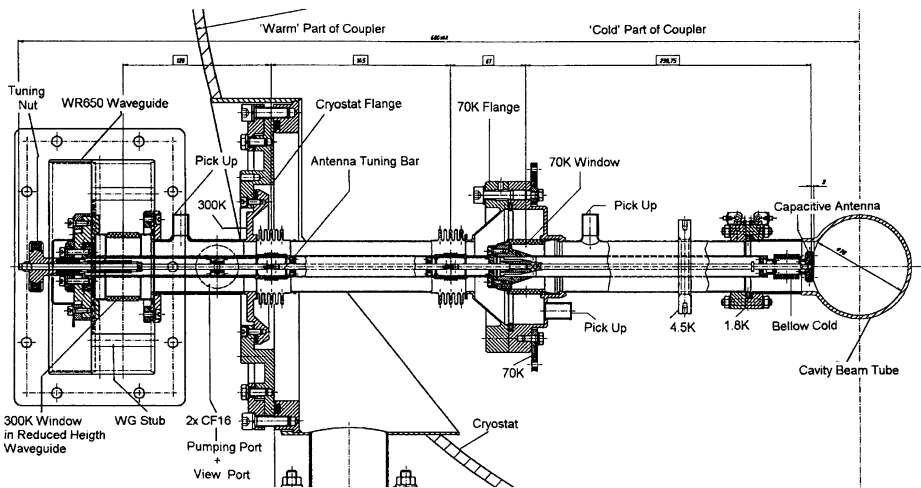

FIGURE 16 The DESY design for the TTF input coupler (B. Dwersteg, DESY).

Two of these form part of the outer conductor, and one forms part of the inner conductor. A coupling adjustment mechanism makes the connection between the input coupler and the vacuum vessel, and provides a means to drive the coupler antenna toward or away from the cavity beam tube. Except for the antenna, which is OFHC copper, the coupler is constructed of copper-plated stainless steel. Vacuum flanges are closed with Helicoflex and Conflat seals. Two instrumentation ports equipped with pickups for monitoring charged particles are located at the conical window. Two more ports are located near the waveguide-to-coaxial doorknob transition, and are intended for vacuum pumping and instrumentation.

Test results on prototypes of the input coupler, on the first two production input couplers, and on a cavity-test coupler (Section 5.1), indicate that the coupler design will meet its electrical requirements. Peak powers in excess of 1 MW have been achieved, as well as operation with the 1.3 ms pulse length at power levels between 200 and 300 kW, traveling wave conditions. The first two production couplers are under preparation for conditioning at DESY, and it is foreseen to mount one of these couplers to the first fully dressed TTF cavity for a horizontal test early in 1996. Twelve of these input couplers are currently under production.

4.2 DESY Input Coupler

The design of the DESY input coupler is shown in Figure 16. This coupler features two cylindrical Al_2O_3 ceramic windows, one at 70 K in the coaxial line, and one at 300 K in the waveguide-to-coaxial transition. The windows are located arbitrarily in the standing wave pattern that occurs during cavity filling at the beginning of each RF pulse. The windows are coated with a layer of titanium nitride on their vacuum surfaces. Two inner/outer conductor bellows pairs are located between the 70 K window and the flange of the vacuum vessel and provide for coupler flexibility. An inner conductor bellows near the antenna tip provides for coupling adjustment. A control rod extends through the coupler to the antenna tip, and is used to drive the tip toward or away from the beam tube. The coupler is constructed mainly of copper-plated stainless steel. Vacuum flanges are closed with Helicoflex and Conflat seals. Three instrumentation ports equipped with pickups for monitoring charged particles are included, two at the 70 K window, and one at the 300 K window. Two more ports near the waveguide-to-coaxial transition are intended for vacuum pumping and instrumentation.

High power RF tests have been performed on the 70 K window in a standing wave coaxial resonator. These tests do not indicate any difficulties with this window design. Four of these couplers are under production, and first tests are foreseen in 1996.

5 INPUT COUPLERS FOR CAVITY TESTING

In addition to the previously described input couplers, which are components that have been or will be installed as part of the semi-permanent structure of a particle accelerator, there is a special class of couplers whose sole purpose is cavity testing. These shall be referred to as cavity-test couplers. The cavity-test couplers generally feature variable coupling, one or two RF vacuum windows, and the capability to be mounted/dismounted to a cavity in a clean room environment. Typically these couplers must operate in a superfluid helium environment and should be usable at power levels high enough to allow for high peak power processing of the cavities. Some recent developments will be described in the following sections.

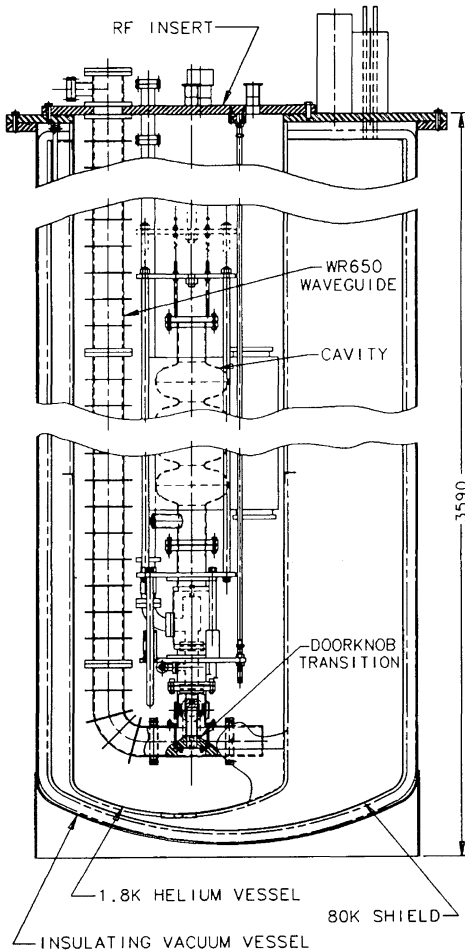

FIGURE 17 The vertical dewar for cavity tests at TTF.²⁴

5.1 TESLA Test Facility Vertical Dewar Cavity-test Couplers

Four cavity-test coupler designs have been implemented for the vertical dewar cavity tests at the TTF. The vertical dewar with RF insert is illustrated in Figure 17. Radiofrequency power is transmitted into the dewar via evacuated rectangular waveguide, which is closed by a room-temperature waveguide

vacuum window above the top plate of the dewar, and by a second vacuum window beneath the cavity. A coaxial line featuring a hydroformed bellows outer conductor joins the cavity to the doorknob transition. The bellows provides for coupling adjustment by raising or lowering the cavity. All of the transmission line components are of stainless steel construction, and some feature copper plating to reduce RF losses.

The first cavity-test coupler, designated *Fermi 1*, used at TTF is shown in Figure 18. It features a cylindrical Al_2O_3 ceramic window which is incorporated into the waveguide-to-coaxial transition. The window is coated with titanium nitride on both sides. The design philosophy for this window called for shielding the ceramic-to-metal braze joints, hence the recesses at both ends of the ceramic cylinder. However, the recess on the outer diameter of the ceramic on the bottom side of the coupler presents a rather large inductance which leads to electric field enhancement (normal to the ceramic surface) between the ceramic and the surrounding metal. In one early test of this coupler, sputtering of silver from the copper-silver braze alloy onto the ceramic and surrounding metal was observed in this region. A new ceramic assembly featuring copper-gold braze alloy was installed, and the antenna length was optimized to minimize the electric fields in the region of the ceramic. (Note that these couplers see primarily standing wave conditions during high peak power processing.) This coupler has been used for cavity tests at TTF for more than one year at power levels up to approximately 1 MW, pulse lengths up to 2 ms, and at a repetition rate of 1 Hz or less. No further sputtering has been observed.

The second cavity-test coupler at TTF, designated *Fermi 2*, is based on the *Fermi 1* design, but features an open geometry at the base of the cylindrical ceramic, as shown in Figure 19. The reason for this modification was to reduce the electric fields normal to the ceramic surface, and to improve the vacuum pumping near the ceramic. This coupler has been prepared and installed on a cavity, and will be tested in the near future.

The third cavity-test coupler at TTF, designated *Fermi 3*, borrows heavily from the Fermilab input coupler design for the TTF accelerator. This coupler is shown in Figure 20, and features a waveguide-to-coaxial transition and a conical coaxial vacuum window which are identical to those in the input coupler design described in Section 4.1. This coupler has performed well at power levels up to 2 MW, and has boosted confidence in the Fermilab input coupler design for TTF. Unfortunately, the coupler has recently developed a vacuum leak across the coaxial window after approximately one year

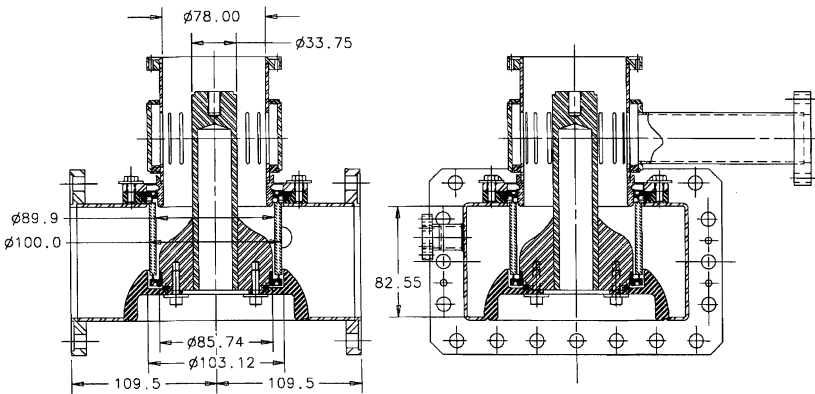
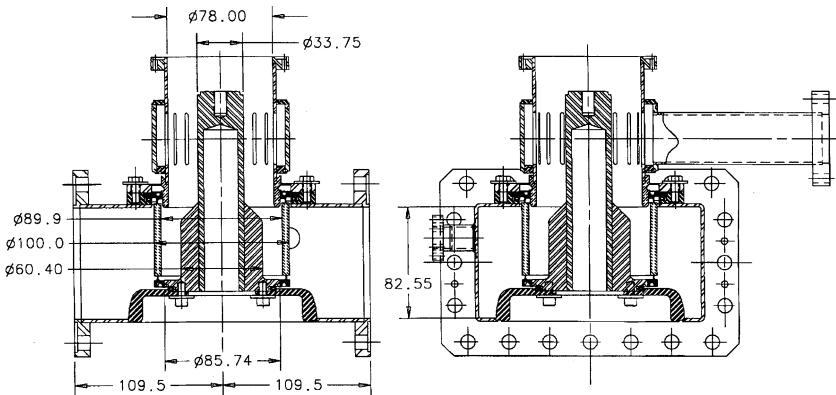
FIGURE 18 The *Fermi 1* cavity-test coupler at TTF.FIGURE 19 The *Fermi 2* cavity-test coupler at TTF.

in service. It is suspected that the leak resulted from mechanical stress during the repeated handling, mounting, and dismounting of the coupler. The leak will be investigated, and the coupler will be repaired with modifications intended to prevent such difficulties in the future.

The fourth cavity-test coupler at TTF is based on the waveguide-to-coaxial transition used in the DESY input coupler design for TTF (see Section 4.2, Figure 16). Compared to the TTF input coupler application, the cavity-test

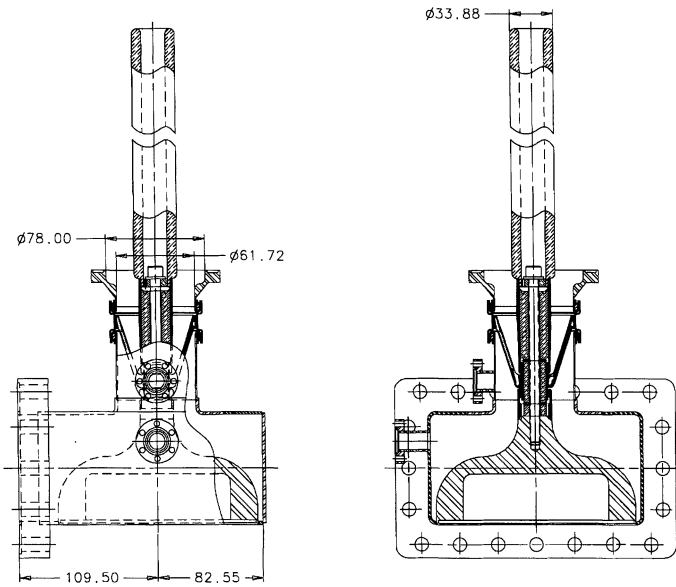

FIGURE 20 The *Fermi 3* cavity-test coupler at TTF.

coupler will have vacuum on both sides of the ceramic window, and the coupler will be immersed in liquid helium at 1.8 K. A version of this coupler is presently being tested.

5.2 Fermilab 805 MHz Input Coupler

A recent collaboration between Fermilab and Los Alamos planned to test the effectiveness of high peak power processing on the 805 MHz niobium cavities developed at Los Alamos.²⁵ A cavity-test coupler was designed at Fermilab, and two couplers were constructed and tested using the Fermilab 13 MW, 805 MHz klystron RF system.

The primary input coupler requirements were adjustable coupling, the capability to be mounted and dismounted in a clean room, and the ability to handle the full power output of the klystron. Because commercially available WR950 waveguide vacuum windows are available at Fermilab, and have been shown to be able to handle the full klystron power, it was decided that the cavity-test coupler design should include one of these windows.

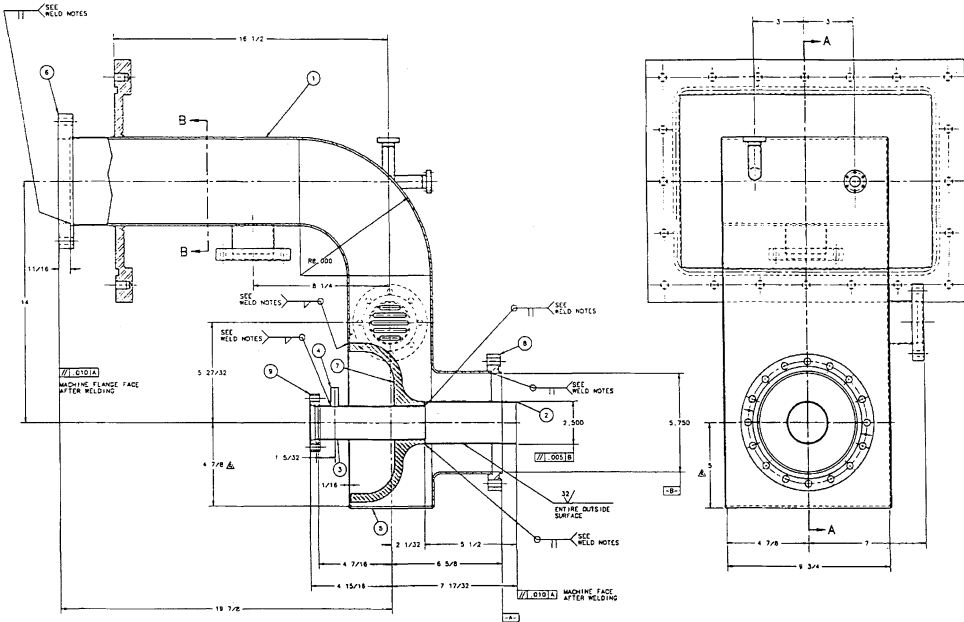

FIGURE 21 The Fermilab 805 MHz cavity-test coupler.

A waveguide-to-coaxial doorknob transition was designed using the High Frequency Structure Simulator (HFSS) from Hewlett-Packard. The coupling to the cavity is via a coaxial line lying on the cavity axis and attached to the beam tube flange of the cavity. Coupling adjustment is provided by means of a bellows on the inner conductor.

Two of the input couplers were fabricated at Fermilab from 316L stainless steel, as shown in Figure 21. Because of the low average RF power, it was decided to forego copper plating. Two optical instrumentation ports were included with views of the waveguide window and the doorknob transition. The coupler design includes channels for liquid nitrogen cooling of the doorknob transition.

The two couplers were joined together at their coaxial flange joints with the vacuum and RF seals provided by a Helicoflex gasket. The waveguide window is mounted to the waveguide with a flange joint that features flat flanges and a silver-plated copper gasket. The gasket is thicker at the inner

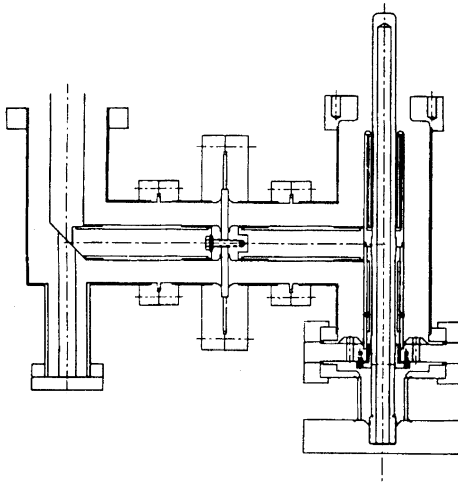

FIGURE 22 The Los Alamos 805 MHz cavity-test coupler.²⁷

edges, and so provides a high quality RF and vacuum connection when the flanges are bolted together. This type of waveguide seal has proven reliable when used at room temperature, and was shown to be vacuum tight to 80 K in at least one test, although low temperature capability is not needed for this input coupler design.

These couplers have been successfully operated up to the maximum available power of 13 MW with 125 μ s pulses at 15 Hz. The occurrence rate of RF trips due to vacuum, light, and reflected power interlocks has steadily decreased with rf conditioning. The couplers have been operated for hundreds of hours at the 10 MW, 125 μ s, 15 Hz power level. Weak multipacting, which does not increase the trip rate or vacuum level, has been observed in the power range of 1.5 MW to 2.0 MW. The signal from the photomultiplier tube indicates light coming from the region of the doorknob transition. The amount of light has decreased with RF conditioning, but has not been eliminated.

5.3 Los Alamos 805 MHz Input Coupler

The cavity-test coupler shown in Figure 22 was developed at Los Alamos for the purpose of testing their single-cell and multi-cell 805 MHz cavities.²⁶

This coupler is entirely coaxial in design, $50\ \Omega$, and capacitively coupled to the cavity via the beam tube. It features an Al_2O_3 disk-type window and variable coupling by means of a choke joint, also at $50\ \Omega$. During pulsed testing the coupler was shown to be capable of handling up to 110 kW at pulse lengths from 0.5 to 1 ms. This power level was set by the maximum available RF power. Continuous wave tests showed a limit of 2 kW due to heating of the inner conductor of the coaxial line. No multipacting was evident at any power level.²⁸ Although the choke joint as a means to provide variable coupling seems to be out of favor at the moment, the success that Los Alamos has had with this design may suggest that it be considered in future applications.

6 CONCLUSION

Numerous input couplers have been presented in the preceding pages, and it is hoped that out of this might come some clear message. Clearly, much of the input coupler advice comes from the experience with the operating systems discussed in Section 2. The high current applications in Section 3 are yielding additional information, followed by the experience with cavity-test couplers described in Section 5. The TESLA Test Facility input coupler of Section 4 is an interesting new application with many challenges, and should in the future provide additional guidance on the design of input couplers.

Problems encountered include damaged vacuum windows, sometimes only sputtered with metal deposits, while other times broken due to arcs and thermal stresses, window arcing phenomena, water leaks, multipacting, vibrations, poorly reproducible coupling ratios, and excessive heating. Some of these problems are interrelated. For example, multipacting can produce excessive localized heating, which in turn produces thermal stresses that can crack a ceramic window. Hidden behind these are myriad production problems involving welding and brazing techniques, copper plating techniques, heat treatment for stress annealing, RRR improvement, and vacuum purposes, cleaning and handling procedures, material selection, and vendor selection.

While many of the characteristics of an input coupler are easily computed with standard codes, the prediction of multipacting remains somewhat elusive. There is no general code that will accept as input the geometry of an input coupler, and provide as output a comprehensive listing of the locations and power ranges where multipacting exists. The cleaning effect of

RF conditioning can reduce or eliminate multipacting, but as is often seen, the multipacting may reappear later due to changing surface conditions. Ideally, a coupler should have a geometry that is free from multipacting up to the maximum required RF power level.

One might ask about the difference between input couplers for normal conducting versus superconducting cavity applications. It seems that the primary difference is that for the superconducting applications, the input coupler necessarily has some surfaces that are cooled to cryogenic temperatures. Whether a ceramic window or the metal walls of a transmission line, these cold surfaces accumulate gases via condensation, and these gases can increase the secondary electron coefficient such that multipacting becomes a problem. Another difference is that the cleanliness requirement of superconducting cavities leads to the placement of a ceramic window very near to the cavity. The energetic electrons and other charged particles, and the X-ray flux in this environment can be extremely detrimental to the window performance.

How then to proceed in the development of an input coupler? Ideally the development team should include or have access to experts in the following areas:

- radiofrequency techniques
- cavities and beam dynamics
- vacuum
- cryogenics
- mechanics
- materials, metallurgy, welding and brazing
- thin film deposition including evaporation, sputtering, and electroplating
- clean room and cleaning techniques

The team should take care not to concentrate too much on any one area at the expense of other areas. For example, input coupler design is frequently performed by rf experts, who may have limited experience in the other required areas of expertise. The team should have adequate financial resources, facilities, and management support. Testing equipment is non-trivial and should be prepared in parallel to the input coupler development. Mounting and handling procedures involving the couplers, coupler test stands, and cavities must be considered. With perseverance, good scientific and engineering techniques, and luck, input couplers that meet their requirements may be developed.

Acknowledgements

The author thanks all of the people working in the field of particle accelerators whose efforts have helped to make this review possible. Special thanks must go to the author's family, whose support and encouragement are much appreciated.

References

- [1] *RF Superconductivity at CEBAF*. The SRF Division, (Proceedings of the 4th Workshop on RF Superconductivity, Tsukuba, 1989).
- [2] B. Yunn and R. Sundelin, *Field Emitted Electron Trajectories for the CEBAF Cavity*. (Proceedings of the 1993 Particle Accelerator Conference, Washington, D.C.).
- [3] V. Nguyen-Tuong, *et al.*, *Electronic Activity at CEBAF Cold RF Window Induced by Cavity Operation*. (Proceedings of the 4th European Particle Accelerator Conference, London, 1994).
- [4] P. Kneisel *et al.*, CEBAF, these proceedings.
- [5] J. Benesch, CEBAF, private communication.
- [6] E. Chiaveri, *et al.*, *Analysis and Results of the Industrial Production of the Superconducting Nb/Cu Cavities for the LEP2 Project*. (Proceedings of the 1995 Particle Accelerator Conference, Dallas).
- [7] J. Tückmantel, *et al.*, *Improvements to Power Couplers for the LEP2 Superconducting Cavities*. (Proceedings of the 1995 Particle Accelerator Conference, Dallas).
- [8] H.P. Kindermann, *et al.*, CERN, these proceedings.
- [9] T. Rietdorf, *Entwurf und Realisierung einer variablen supraleitenden Hochfrequenz-Einkopplung für die Beschleunigungsstrukturen des supraleitenden Darmstädter Elektronenbeschleunigers S-DALINAC*. (Dissertation, Technische Hochschule Darmstadt, Germany, 1993).
- [10] B. Dwersteg and Q. Yufang, *High Power Input Coupler Developments at DESY*. (Proceedings of the 4th Workshop on RF Superconductivity, Tsukuba, 1989).
- [11] J. Sekutowicz, DESY, these proceedings.
- [12] S. Noguchi, *et al.*, *Couplers – Experience at KEK*. (Proceedings of the 4th Workshop on RF Superconductivity, Tsukuba, 1989).
- [13] T. Furuya, *et al.*, *Activities of RF Superconductivity at KEK*. (Proceedings of the 6th Workshop on RF Superconductivity, Newport News, 1993).
- [14] T. Shishido, *et al.*, *Operating Status of the TRISTAN Superconducting RF System*. (Proceedings of the 3rd European Particle Accelerator Conference, Berlin, 1992).
- [15] D. Metzger, *et al.*, *Test Results and Design Considerations for a 500 MHz, 500 kWatt Vacuum Window for CESR-B*. (Proceedings of the 1993 Particle Accelerator Conference, Washington, D.C.).
- [16] H. Padamsee, *et al.*, *Beam Test of a Superconducting Cavity for the CESR Luminosity Upgrade*. (Proceedings of the 1995 Particle Accelerator Conference, Dallas).
- [17] M. Pisharody, *et al.*, *High Power Window Tests on a 500 MHz Planar Waveguide Window for the CESR Upgrade*. (Proceedings of the 1995 Particle Accelerator Conference, Dallas).
- [18] R. Rimmer, *et al.*, *High-Power RF Cavity R & D for the PEP-II B Factory*. (Proceedings of the 4th European Particle Accelerator Conference, London, 1994).
- [19] M. Neubauer, *et al.*, *High-Power RF Window Design for the PEP-II B Factory*. (Proceedings of the 4th European Particle Accelerator Conference, London, 1994).
- [20] M. Neubauer, *et al.*, *High-Power RF Window and Coupler Development for the PEP-II B Factory* (Proceedings of the 1995 Particle Accelerator Conference, Dallas).

- [21] B. Dwersteg, *High Power Couplers*. (Proceedings of the 4th Workshop on RF Superconductivity, Tsukuba, 1989).
- [22] F. Naito, *et al.*, *Input Coupler for the KEKB Normal Conducting Cavity*. (Proceedings of the 1995 Particle Accelerator Conference, Dallas).
- [23] J. Kirchgessner, *Review of the Development of RF Cavities for High Currents*. (Proceedings of the 1995 Particle Accelerator Conference, Dallas).
- [24] T. Nicol, *et al.*, *TESLA Vertical Test Dewar Cryogenic and Mechanical Design*. (Proceedings of the 1993 Particle Accelerator Conference, Washington, D.C.).
- [25] B. Rusnak, *et al.*, *Superconducting Multicell Cavity Development Program at Los Alamos*. (Proceedings of the 1993 Particle Accelerator Conference, Washington, D.C.).
- [26] E. Gray and G. Spalek, *Power Coupler and Cold Window for Seven-Cell Superconducting Cavity Vertical Test*. (1992 Linear Accelerator Conference, Ottawa, Ontario).
- [27] B. Rusnak, *et al.*, *Status of RF Superconductivity at Los Alamos National Laboratory*. (Proceedings of the 6th Workshop on RF Superconductivity, Newport News, 1993).
- [28] B. Rusnak, Los Alamos, private communication.