

CERN
CH-1211 Geneva 23
Switzerland

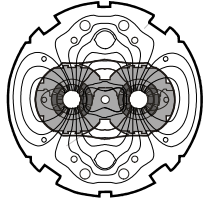

the
**Large
Hadron
Collider**
project

LHC Project Document No.

LHC-B-ES-0007 rev 1.1

CERN Div./Group or Supplier/Contractor Document No.

AB-BDI

EDMS Document No.

347396

Date: 2004/04/15

Functional Specification

ON THE MEASUREMENT OF THE RELATIVE LUMINOSITY AT THE LHC

Abstract

This functional specification defines the requirements for the measurement and optimization of the interaction rates or relative luminosity at the four LHC interaction points. The beam and machine scenarios and the anticipated uses in operation are analysed to define the required dynamic ranges, precision, time response,...of the machine luminometers. The potential for absolute calibration, the complementarities with the experimental absolute luminometers and the data exchange between machine and experiments are discussed and specified. The requirement for the measurement of the background to the experiments by standardized detectors was identified and will be dealt with in a separate document.

<p><i>Prepared by</i></p> <p>R. Assmann/AB-ABP J.P. Koutchouk/AB-BDI M. Placidi/AB-BDI E. Tsesmelis/TS-LEA</p>	<p><i>Checked by :</i></p> <p>Oliver Brüning [AB/ABP] J-Jacques Gras [AB/BDI] Rüdiger Schmidt [AB/CO] Jörg Wenninger [AB/OP]</p>	<p><i>Approval Leader :</i></p> <p>Roland Jung AB/BDI</p>
--	--	--

Approval Group Members

LTC: S. Myers, P. Collier; AB/ABP: J.-P. Riinaud, S. Fartoukh, W. Herr, F. Ruggiero;
AB/BDI: H. Schmickler, R. Jung, E. Bravin, W.C. Turner; AB/OP: S. Baird, K. Cornelis;
TS/LEA: K. Potter, D. Macina; ALICE: D. Evans, C. Fabjan, L. Leistam, A. Morsch;
ATLAS: N. Ellis, P. Grafstrom, M. Nessi; CMS: A. Ball, A. Herve, M. Huhtinen, W. Smith;
LHCb: R. Jacobsson, A. Smith, W. Witzeling; TOTEM: M. Bozzo, K. Eggert, M. Oriunno

History of Changes

<i>Rev. No.</i>	<i>Date</i>	<i>Pages</i>	<i>Description of Changes</i>
0.4	11/06/2003		Final draft presented in BDI TB and LTC. Submitted to approval.
1.0	02/03/2004		<u>Modifications after the comments of the Approval process:</u>
		All	<ul style="list-style-type: none"> • All numerical figures updated with the latest LHC parameters (2004) • Totem-like requirements updated and better spelt out.
		Sections 1 and 3	Clarification on the goals of this specification and on the role of the machine luminometer and standard background monitors
		Table 1	Update and corrections
		Section 4.4 and Table 7	<ul style="list-style-type: none"> • Clarification of the topology of the crossings and their ranges • Include topological restrictions for horizontal crossings
		Section 5 pages 9 to 14	Requirement on precision somewhat relaxed when possible
		Section 6 pages 14 to 17	Corrections and update with latest information from LEADE
		Section 7.1 and 7.5.4	Requirement to install a monitor on each side of each IR emphasized
		Section 7.3	Open the possibility of integration over a few bunches instead of one if necessary
		Section 7.4.3	Open the possibility of reducing the dynamic range for very low luminosities.
	14/04/2004	Section 4.4 and Table 7	Further clarification and final update of the crossing topology and its possible variations following memo by AB/ABP.
1.1	23/07/2004		Released Version

Table of Contents

1.	SCOPE	5
2.	BEAM OBSERVABLE AND DERIVED BEAM PARAMETERS.....	5
3.	STRATEGY AND RESPONSIBILITIES	5
3.1	LUMINOSITY	5
3.2	BACKGROUNDS TO THE EXPERIMENTS.....	6
4.	BEAM AND MACHINE CONDITIONS.....	6
4.1	RUNNING SCENARIOS.....	6
4.2	RANGE OF BEAM PARAMETERS.....	6
4.2.1	INITIAL LUMINOSITY	6
4.2.2	LUMINOSITY DECAY	8
4.3	IONS	8
4.4	RANGE OF MACHINE CONDITIONS.....	8
5.	DESCRIPTION OF THE ANTICIPATED USES.....	10
5.1	INITIAL BEAM FINDING & OVERLAP MAXIMIZATION	10
5.2	MANUAL LUMINOSITY MAXIMIZATION FOR PHYSICS RUNS	10
5.3	AUTOMATED BEAM OVERLAP FEEDBACK	11
5.4	EQUALIZATION OF THE LUMINOSITY AMONGST THE EXPERIMENTS	11
5.5	ADJUSTMENT OF THE LUMINOSITY FOR ALICE.....	12
5.6	MINIMIZATION OF BEAM-BEAM EXCITATION	12
5.7	MONITORING OF THE CROSSING ANGLE	13
5.8	MONITORING OF THE VERTEX POSITION	13
5.9	BUNCH-BY-BUNCH MEASUREMENT OF LUMINOSITY	13
5.10	MONITORING OF THE BACKGROUNDS	14
5.11	LOGGING	14
5.12	POST-MORTEM ANALYSIS	14
6.	MACHINE AND EXPERIMENT INFORMATION EXCHANGE.....	15
6.1	DATA FLOW: EXPERIMENTS TO MACHINE	16
6.1.1	CAPABILITIES OF THE BUS.....	16
6.1.2	DATA PROVIDED BY ATLAS/CMS	16
6.1.3	REQUIREMENTS FROM MACHINE LUMINOMETERS.....	17
6.2	DATA FLOW: MACHINE TO EXPERIMENTS	17
7.	FUNCTIONAL REQUIREMENTS	18
7.1	LAYOUT.....	18
7.2	GEOMETRICAL ACCEPTANCE	19
7.3	SAMPLING FREQUENCY	20
7.4	DYNAMIC RANGES	20
7.4.1	BEAM ENERGY	20
7.4.2	PARTICLE SPECIES	20
7.4.3	LUMINOSITY.....	20
7.5	PRECISION, CALIBRATION AND INTEGRATION TIMES.....	21
7.5.1	RESOLUTION AND INTEGRATION TIME.....	21

7.5.2	RELATIVE CALIBRATION.....	21
7.5.3	ABSOLUTE CALIBRATION	21
7.5.4	ROBUSTNESS AGAINST BACKGROUND.....	22
7.6	DATA FLOWS	22
8.	DESIGN CONSTRAINTS.....	22
8.1	INB CONSTRAINTS	22
9.	RELIABILITY, AVAILABILITY AND MAINTAINABILITY	23
10.	SAFETY AND REGULATORY REQUIREMENTS.....	23
11.	ACKNOWLEDGMENTS	23
12.	REFERENCES	23

1. SCOPE

This functional specification defines the goals and requirements for the measurement and optimization of the interaction rates at the four LHC interaction points. Some initial requirements or estimated performance were listed in the Conceptual Design Report [1]. At this stage, it was not yet possible to mitigate the requirements with the performance prospects of the luminometers. We have based our analysis on beam dynamics issues and some experience in other machines. The experimental detectors will as well measure the luminosities and backgrounds. The complementarity of the two systems and the data exchanged between both are discussed.

The beam energies are quoted in terms of the accelerator energy, i.e. the energy per unit charge.

2. BEAM OBSERVABLE AND DERIVED BEAM PARAMETERS

The number of particles produced in beam-beam collisions is proportional to the luminosity. The rate of a fraction of the collision products is the most natural primary observable of luminosity. The detectors shall be installed at each collision point and are characterized by their acceptance [1]. We call these detectors "luminometers" in the following. Another potentially interesting observable of luminosity is the beam-beam electro-magnetic coupling [2]. It however measures a vector sum of the luminosities over one turn and cannot replace the particle detection.

The performance parameters derived from the measured rate of collision products (primary observable) are:

- the relative luminosity: this quantity is proportional in an unknown **but constant** way to the actual luminosity; this implies insensitivity or correction of the detectors to the vertex position, background level,...; the proportionality constant may differ from IP to IP.
- the transverse separation of the two beams; this requires measuring luminosity while changing the beam-beam separation.
- the crossing angle, if the particle counters are granular.

Besides the interaction rates, the background to the experiments is another primary observable relevant to the machine optimization (beam-gas, beam-pipe).

3. STRATEGY AND RESPONSIBILITIES

3.1 LUMINOSITY

A strict separation between absolute and relative luminosity monitors appears both artificial and counter-productive in view of the anticipated uses discussed in section 5. The machine luminometers can indeed be calibrated by the van der Meer method; however their absolute calibration cannot be guaranteed in all operating conditions (systematic errors during the measurement procedure).

The strategy is as follows:

- It is the responsibility of the experiments to measure their own absolute luminosity.
- Standardized, simple, fast and robust machine luminometers are provided to set up the machine for physics and optimize its performance based on counting rates. Provisions for an absolute calibration of the machine luminometers will be anticipated.

From experience, cross-checks with measurements from the LHC detectors are very valuable to understand possible differences in the luminosities of LHC IR's.

-
- The beam parameters necessary to calculate the luminosity will be transmitted to the experiments (optics parameters, bunch-by-bunch beam emittances and currents).

3.2 BACKGROUNDS TO THE EXPERIMENTS

The minimization of the beam background to the experiments is an issue for the LHC. The four insertions should be equipped with identical or similar detectors of forward particles under the control of the machine. They should provide information useful for the machine optimization, the ability to provide similar beam conditions from run to run and the understanding of pathologies. Their use to monitor single beam rates is also relevant. These standard monitors complement the experiment specific background signals sent to the control room.

A Beam Condition Monitor is being studied by CMS for the monitoring of tracking system backgrounds and if necessary for equipment protection via the generation of a beam abort request. These studies could lead to the specification of a standard machine background monitor applicable to all experiments [3].

4. BEAM AND MACHINE CONDITIONS

The luminometers and background monitors must cover a large range of beam and machine parameters defined hereafter. The presented numbers refer to the design parameters of the LHC in the beginning of 2004.

4.1 RUNNING SCENARIOS

In addition to the baseline running scenarios [4] (initial, nominal, ultimate running) we have included in Table 1 a few cases that are important for set-up and optimisation of collisions.

Collision studies with single bunches and possibly large beam size at the interaction points (unsqueezed optics) would enable us to commission and optimise the collider in an efficient and modular way. With single bunches the p-p collisions can be set up in a selected interaction point with a separation bump in the opposite IP. Once well-controlled collisions and a good single-bunch orbit are established, the additional complications of the crossing bump, squeezed optics, multiple interaction points, and multi-bunch effects can be introduced one by one. We note that collision studies in this scenario are not time-critical, i.e. long integration times are acceptable for luminosity measurements.

Additional scenarios can be imagined, like special patterns of a few bunches that collide simultaneously in all interaction points. These have not been included, as the luminosity in each interaction point is similar to the single bunch cases, which are listed.

4.2 RANGE OF BEAM PARAMETERS

4.2.1 INITIAL LUMINOSITY

The expected range of luminosity in the LHC is summarized in Table 1 for a subset of possible running scenarios. The goal is to identify the dynamic range of the luminosity to be measured; hence this list need not be exhaustive for intermediate cases.

Bunch population	Number of bunches	Bunch spacing	Mode	Experiment (not exclusive)	IP beta	Luminosity [$\text{cm}^{-2} \text{s}^{-1}$]
<i>(a) Collision studies with single pilot bunch, no crossing angle</i>						
5×10^9	1	n/a	p-p	ATLAS/CMS	18 m	2.5×10^{26}
					1.2 m	3.7×10^{27}
				ALICE, LHC-b	10 m	4.4×10^{26}
<i>(b) Collision studies with single higher intensity bunch, no crossing angle</i>						
2.75×10^{10}	1	n/a	p-p	ATLAS/CMS	1.2 m	1.1×10^{29}
1.15×10^{11}					0.55 m	4.3×10^{30}
				ALICE	10 m	2.4×10^{29}
				LHC-b	35 m	6.7×10^{28}
<i>(c) Early p-p luminosity run (different scenarios)</i>						
2.75×10^{10}	43	2.025 μs	p-p	ATLAS/CMS	1.2 m	4.8×10^{30}
1.15×10^{11}						8.4×10^{31}
4.0×10^{10}	2808	25 ns				6.5×10^{32}
1.15×10^{11}	936	75 ns				1.8×10^{33}
<i>(d) Nominal p-p luminosity run</i>						
1.15×10^{11}	2808	25 ns	p-p	ATLAS/CMS	0.55 m	1.0×10^{34}
				LHC-B	35 m	1.9×10^{32}
				ALICE ¹	10 m	$\leq 3.0 \times 10^{30}$
<i>(e) Ultimate p-p luminosity run</i>						
1.67×10^{11}	2808	25 ns	p-p	ATLAS/CMS	0.5 m	2.3×10^{34}
<i>(f) TOTEM runs</i>						
3×10^{10} , $\epsilon_N = 1 \cdot 10^{-6}$	43	2.025 μs	p-p	TOTEM(7 TeV)	1540 m	1.7×10^{28}
1.15×10^{11}	2808	25 ns	p-p	TOTEM	18 m	3.6×10^{32}
<i>(g) Ion runs</i>						
7×10^7	1		Pb-Pb	ALICE/ATLAS/CMS	0.5 m	1.7×10^{24}
	592					10^{27}

Table 1: A sample of possible running scenarios used to define the range of initial luminosities to be measured. The numbers are based on the LHC design in the beginning of 2004.

The first scenario involving the collision of pilot bunches in the un-squeezed optics extends significantly the dynamic range. It should be noted that it is not strictly required but would greatly help the commissioning if this measurement is technically possible. The integration time is not constrained.

¹ In p-p mode the beam-beam collision offset is adjusted such that the goal luminosity is obtained. Running at 10^{29} with a detuned insertion is equally foreseen.

4.2.2 LUMINOSITY DECAY

We note that the quoted luminosity values refer to initial peak luminosity and that the luminosity will decay during a luminosity run. With the calculated nominal luminosity lifetime of 13.9 hours [5] and an assumed maximum run length of 20 hours it is expected that luminosity will decay to 25% of its peak value. We assume a decay factor of five, adding a safety margin for additional losses, for example intensity losses during ramp or squeeze. The effective range in luminosity measurement should then reach at least a factor of 5 below the specified range in initial peak luminosity, except for the case of pilot collisions where a factor of 2 is sufficient.

4.3 IONS

For the commissioning, the only scenario included in the LHC baseline programme is the collision of lead ions at 7 TeV. The LHCC [6] endorsed as well Pb-p collisions. It noted that other ions are of a lesser priority and that there are no compelling physics reasons for a deuteron programme. The ALICE programme presented in [10] is somewhat richer. In addition to the basic Pb-Pb running, the following scenarios would be anticipated:

- pPb or (d(α) Pb)
- Ar-Ar

And the following options should be considered for later running:

- p-p, d-d, α - α at 2.75 TeV,
- Another ion species A of intermediate mass amongst N, O, Kr, Sn,
- p-A or d-A or α -A
- Pb-Pb at an energy lower than 7 TeV.

The requested luminosities are given in [29].

The initial peak luminosity for Pb-Pb collisions is low compared to the p-p collisions. Allowing for single bunch set-up of ion collisions with nominal bunch intensity will produce an initial peak luminosity of just $0.9 \times 10^{24} \text{ cm}^{-2} \text{ s}^{-1}$. However the cross sections for Pb-Pb are much higher than for p-p; the event rates from ion-ion collisions will nonetheless be high. We therefore separate in the following the specifications for protons and ions.

4.4 RANGE OF MACHINE CONDITIONS

In addition to the beam parameters listed in Table 1 a number of other machine parameters are relevant to the measurement of the luminosity and background. Their nominal values and expected range are listed below [7] [8]:

1. Topology of the beam crossing:

The topology of the LHC beam crossing is somewhat involved. It is discussed here. The nominal scheme is given in

Table 2 and in Table 7 where its variations to be anticipated are also included.

- a. Plane of the crossing angle: In ALICE and LHC-b, the planes are fixed by the topology of their spectrometers. In CMS and ATLAS, the requirement of a beam screen in the low-beta triplet fixes the plane of crossing at nominal luminosity in their nominal positions. It should be noted that the plane of crossing can be almost freely chosen while running with a larger beta function at the IP (twice the nominal value). The only restriction is the avoidance of a triple crossing, see Table 7.

- b. *Value of the total crossing angle*: the total crossing angle between beam 1 and beam 2 (orbit bump and spectrometer bump) varies considerably. The nominal angles and planes of crossing are summarized in Table 2 for p-p collisions. TOTEM runs have a nominal crossing angle of zero, which will also be employed for setting up collisions with a few bunches. The aperture of the low- β quadrupoles could allow a maximum crossing angle of $\pm 200 \mu\text{rad}$ [9].
- c. *Sign of the crossing angle*: If the beams cross in the vertical plane, the sign of the crossing angle is in principle free. If the beams cross in the horizontal plane, the sign is constrained to enforce a single encounter. This is obtained when the crossing angle points the beam towards the channel it will use after the D1/D2 separator magnets. It is important to note that the crossing plane, and hence the sign of the crossing angle, become free if the β function is relaxed by a factor of 2 or in case of an upgrade of the low- β quadrupoles.
2. *Transverse position of the vertex*: The transverse centering of the interaction point can vary due to orbit or alignment changes. The tolerances for changes in the transverse collision point are set from the experiments to be $\pm 1 \text{ mm}$ for run-to-run and $\pm 3 \text{ mm}$ for longer term movements. This tolerance refers to the experimental geometry; the IP must be centered in the experimental detector to within this tolerance. We note that the detectors are expected to experience significant movements and that the acceptable change from the machine side is then less than the $\pm 3 \text{ mm}$.
 3. *Longitudinal position of the vertex*: The longitudinal position of the vertex is expected to be stable within $\pm 4.2 \text{ cm}$ with the estimated RF phase noise (LEADE 15/01/2002). With experience and better control, it is hoped to reduce its range to $\pm 1 \text{ cm}$. This is consistent with the experimental requirement of at least 95% of the proton-proton interactions to occur within a region of $\pm 11.2 \text{ cm}$, centred on the nominal interaction point at the centre of the detector.
 4. *Option*: The installation of a TOTEM-like experiment in ATLAS [28] is under study. It would require similar machine conditions as that in CMS for TOTEM [10], except for a somewhat higher β^* (2625m).

IR	Experiment	IP beta	Crossing angle plane	Half total crossing angle	Range for nominal cases
1	ATLAS	0.55 m	Vertical	$\pm 143 \mu\text{rad}$	
2	ALICE	10 m	Vertical	$\pm 150 \mu\text{rad}$	$\pm(35-150) \mu\text{rad}$
5	CMS	0.55 m	Horizontal	$\pm 143 \mu\text{rad}$	
5	TOTEM	1540 m	Horizontal	0 μrad	
8	LHC-B	1 \rightarrow 50 m	Horizontal	$\pm 285 \mu\text{rad}$	$\pm(200-285) \mu\text{rad}$

Table 2: Nominal beam crossing parameters (beginning 2004).

5. DESCRIPTION OF THE ANTICIPATED USES

Unless specified otherwise, the luminosity considered in the following refers to the luminosity averaged over all bunches.

5.1 INITIAL BEAM FINDING & OVERLAP MAXIMIZATION

At first the Beam Position Monitors (BPM's) will be used to bring the beams in collision at the IP's. Due to their finite resolution δ_{res} and the small beam size, the overlap will be imperfect. The residual beam separation is estimated to be about $\Delta y_{ip} \approx \sqrt{2} \cdot \delta_{res}$ [11]. The BPM's are located in a difficult area (high background rates) and a conservative resolution of 150 μm is assumed. The expected residual beam separation is then about 200 μm , corresponding to about 13 σ with $\beta^*=0.5$ m (squeezed optics) and to about 2 σ with $\beta^*=18$ m (injection and ramp optics). The latter scenario is obviously better suited for commissioning. During this period, the use of a single bunch of moderate intensity or a pilot bunch is anticipated.

The beams can then be put into full collision by maximizing the relative luminosity signal. The beam-beam separation knobs are changed in a systematic way in order to explore the transverse plane with both beams. Larger beam size (100 μm instead of 18 μm) allows fewer steps during this possibly lengthy process, thus reducing the required set-up time, the tolerances on orbit drifts etc. This use requires a high-resolution luminosity measurement (resolution about $10^{28} \text{ cm}^{-2} \text{ s}^{-1}$ for one nominal bunch and better than $10^{26} \text{ cm}^{-2} \text{ s}^{-1}$ for one pilot bunch), which can be integrated over minutes, if required. A moderate accuracy of about $\pm 10\%$ is sufficient.

5.2 MANUAL LUMINOSITY MAXIMIZATION FOR PHYSICS RUNS

The principal application of the luminometers will be the optimization of luminosity during physics running. The first phase in this optimization will be an initial tuning at the start of the fill, requiring fast response with good resolution and reproducibility (thus allowing comparison to the previous fill). The second phase will be more or less continual maximization during the luminosity production, often involving trial and error on several beam parameters. The success of tuning is always judged through the change in the luminosity signal. As the possible magnitude of changes is very much constrained in the LHC only small improvements can be expected and a good luminosity resolution is mandatory. We require a luminosity resolution of a few per cent within a second for the initial scenario (Table 1(b)) reaching $\pm 1\%$ or better for nominal performance. For a successful optimization, it is important that the sensitivity of the luminometer to the vertex position be smaller than the resolution. This should yield a reproducibility from fill to fill of about 1%. This very high level of reproducibility would be a great advantage if the LHC operation was otherwise automated. Actually, a reproducibility of 5% seems sufficient to guide correctly the machine operation.

5.3 AUTOMATED BEAM OVERLAP FEEDBACK

A procedure has been proposed [12] to keep the beam in collision within 0.1σ - 0.2σ by a continuous micro-steering of the beams while monitoring the average luminosity. The varying beam separation shall be smaller than 0.2σ to avoid a beam-beam excitation at nominal performance level (see section 5.6). If the micro-steering is done in steps of 0.05σ , then the requirement in resolution is more severe than that of section 5.2 i.e. $\pm 0.25\%$. The response time of the feedback loop need not be fast, as the phenomena leading to a beam separation are slow (e.g. local orbit drifts due to magnet motion). A correction rate of 1 Hz seems appropriate and consistent with the response time of the orbit correctors (1.7 A/s max for a dynamic range of 60 A and about 1 A per σ needed).

5.4 EQUALIZATION OF THE LUMINOSITY AMONGST THE EXPERIMENTS

Experience shows that issues such as unexpected discrepancies between the absolute luminosity measured by various experiment detectors do occur. A proper evaluation of the systematics in the experimental luminometers remains a challenge, especially if, as foreseen, ion operation does not come first [10]. In such a situation, it will be necessary to disentangle real machine issues (e.g. perturbations of the local optics), from detector issues. An absolute calibration of the machine luminometer should be very helpful:

1. The first possibility is a run-by-run monitoring of the calibration factor between the measured interaction rates and the absolute luminosity measured by the experiments. This allows a check of the overall consistency and requires a reproducibility of the luminometers from run to run in the $\pm 1\%$ range when the beam positions and sizes can be different.
2. An actual 'free' absolute calibration of the machine luminometers is possible by the van der Meer method. The principle, developed for the ISR, is to measure the interaction rate versus the beam separation. The normalization by the maximum rate yields the effective beam dimensions. The luminosity is calculated from the effective dimensions of the interaction area and the beam currents. In the LHC, the scans can be either in the transverse plane (2D) or in the longitudinal plane (1D) [13]. In the course of the transverse scan, the longitudinal position of the vertex changes due to a pure geometric effect of the crossing angle. The accuracy of the method remains to be studied for the LHC. With much care it reached about $\pm 1\%$ in the ISR [14]. To facilitate this measurement, the luminometer should ideally be insensitive (within better than $\pm 1\%$) to a variation of the vertex position of about ± 1 mm transversely and ± 20 cm longitudinally (transverse scan). It is noted that the longitudinal variation can reach up to about ± 1 m for the longitudinal scan [13]. If this does not turn out to be achievable, it should be possible to re-center the vertex by means of orbit bumps and the RF phase. It should be noted that, during the scan, the background may vastly change, making it difficult to measure the tails of the overlap integral.

The overall accuracy of the absolute calibration should match the anticipated accuracy of the experiment detectors (better than 5% [10]) to be helpful.

5.5 ADJUSTMENT OF THE LUMINOSITY FOR ALICE

In proton mode, ALICE requires a transverse beam separation that depends on the machine performance, the goal being to provide a maximum luminosity of $3.0 \times 10^{30} \text{ cm}^{-2} \text{ s}^{-1}$. For nominal performance a beam separation of 5σ is required. The preparation of this machine condition shall be carried out with the machine luminometers. For that purpose, a crude absolute calibration of the machine luminometer is required to within a factor 10 to 100 (under study) [25].

Another important issue is the dose rate to the ALICE detector during the beam scan. At the full nominal luminosity of $1.0 \times 10^{34} \text{ cm}^{-2} \text{ s}^{-1}$, one hour of head-on collision in ALICE produces as much dose as one year at the nominal ALICE luminosity. The machine luminometers should monitor the luminosity and issue alarms to keep the doses due to the beam scans or operation hazards well below the nominal doses [25]. In practice, the preferred procedure should be to start a scan from a state where the beams are separated by more than 5σ , i.e. at very low luminosity levels. Once the good working point has been established orbit feedbacks on both beams will maintain the beam-beam separation. We assume that the protection of the experiment against excessive doses is guaranteed by other means with proper warnings to the control room as the time scale allows human corrective actions.

5.6 MINIMIZATION OF BEAM-BEAM EXCITATION

A small parasitic beam separation, of little or no practical consequence on the luminosity, has been identified as a source of background and/or reduced lifetime in Sp \bar{p} S and HERA [15], [16]. Potentially too small for detection by the IR BPM's, it could be detected by the luminometer. The tolerance for allowable beam-beam offsets is estimated to be about 0.1σ - 0.3σ from the above-mentioned sources. Both the average offset between the beams and the offset in each bunch collision are important. The former can be corrected while the latter is more difficult to act on. Controlling these offsets may nevertheless lead to a better understanding of the machine performance. The luminosity with a beam-beam offset Δy_{IP} is given by:

$$L \approx L_0 \cdot e^{-\left[\Delta y_{IP}^2 / (2\sigma_y^*)^2\right]}$$

For a 0.2σ beam-beam offset tolerance we find a reduction in luminosity of 1%. In order to detect a parasitic separation, the resolution of the luminometer shall be better than $\pm 1\%$. The integration time shall be small as compared to the phenomena which lead to a beam separation of 0.1σ (e.g. orbit drifts for the whole beam, PACMAN effects from bunch to bunch). Orbit drifts typically occur over minutes (damped by slow feedbacks) and PACMAN effects are quasi-static. A 1% bunch-to-bunch resolution is required as well in order to allow analysis and minimization of the beam-beam offsets from bunch to bunch with the luminometer. It is noted that these subtle effects may also be studied via the beam-beam transfer function [2],[17] using electro-magnetic devices.

5.7 MONITORING OF THE CROSSING ANGLE

The crossing angle decreases the luminosity (L) compared to head-on collisions (L_0) following:

$$L = L_0 \frac{1}{\sqrt{1 + \left(\frac{\phi \sigma_s}{2\sigma_\beta}\right)^2}} \quad \text{hence} \quad \frac{\Delta L}{L} \approx -1132 \Delta\phi \quad \text{for nominal parameters.}$$

ϕ is the full crossing angle, σ_β and σ_s the rms beam size and length. The measurement of the luminosity to the 1% level implies a knowledge of the crossing angle to 3%, i.e. $\pm 11 \mu\text{rad}$. The crossing angle is a key parameter for the minimization of the adverse effect of the long-range beam-beam interactions. An estimate of the required accuracy for beam dynamics [18] gives a similar value of $\pm 7 \mu\text{rad}$. The TOTEM experiment requires a control of this angle to a significantly lower value of $0.2 \mu\text{rad}$.

The crossing angle can be measured with the BPM's. The estimated accuracy is about $\pm 10 \mu\text{rad}$ for normal bunches but could be three times better for some PACMAN bunches when the time of separation between the passage of the two beams at the Q1 BPM is increased and in the TOTEM running scenario of 43 bunches.

The measurement of the crossing angle with a granular luminometer offers potentially a higher resolution measurement given the much increased lever arm. This would be valuable to meet the TOTEM demand. Other methods involving a calibration of the BPM position versus the TOTEM detector position have to be investigated. A redundant measurement of the angle may prove valuable if the BPM at Q1 would suffer from the flux of charged secondaries from the IP.

5.8 MONITORING OF THE VERTEX POSITION

The experiments and the machine luminometers have a limited acceptance both in transverse and longitudinal position. The monitoring of the vertex position is thus necessary. The most natural and precise monitors are the experiments themselves, as already foreseen (section 6.1). The data should be transferred to the control room at a slow rate (about every 10 minutes or faster). During van der Meer scans, a rate of 1/mn can be useful.

5.9 BUNCH-BY-BUNCH MEASUREMENT OF LUMINOSITY

The limit of LHC performance is presently expected to be the long-range beam-beam effect. Not all bunches suffer the same perturbations. Therefore, there is a strong incentive to measure the relative luminosity bunch-by-bunch when the performance of the machine approaches about 50% of its nominal value. At a lower performance level, the anticipated electron clouds may produce similar effects. The experience in the B-factories shows that indeed strong variations can be observed along long bunch trains, e.g. due to collective instabilities (e-cloud, ...). Together with the bunch-by-bunch measurement of the beam current position and emittance, the bunch-by-bunch luminosity measurement should help the diagnostic of selective blow-up, coherent oscillations, etc...

The luminosity resolution per bunch should be of the order of a few percent and less than 10% to be useful. The integration time is not really constrained. About 1 minute or less is convenient for operation.

The beam-beam transfer function might offer a useful means of comparing the bunch luminosities. **It should be noted that a bunch-by-bunch excitor is needed to measure the beam-beam transfer function.**

5.10 MONITORING OF THE BACKGROUNDS

Although not discussed in this specification, the background monitors are of great importance when maximizing the effective luminosity. For completeness, they are mentioned here. The low-beta insertions are rather complicated, making the machine optimization a possibly tedious process. The measurement of the background caused by beam-gas interactions or by the interactions of the halo particles with the surroundings can be expected to be valuable in optimizing the insertions for performance and for reproducibility. This was the case in the ISR where dedicated machine monitors were provided and is confirmed at RHIC. The monitoring shall be bunch-by-bunch to detect pathological bunches. The background signal could also be suitable to center the vertex by minimizing the background. It is equally valuable for carrying empirical machine optimization (tunes, orbits, coupling,...).

The integration time shall be less than or equal to 1 s for initial machine performance to allow for efficient optimizations. In other machine scenarios, it would be convenient not to integrate for more than a few seconds. The only relevant component of the precision is the resolution. The background being a very sensitive signal, it does not seem easy to specify a useful resolution. A figure better than 10% and ideally of the order of 1% seems appropriate.

It is pointed out that the luminometers themselves are also subject to background. The appropriate background subtraction and control requires further studies, but it is expected that a good background correction can be done by using the information of the luminometers from both sides of the interaction point.

5.11 LOGGING

The bunch luminosities and backgrounds should be logged for later analysis. The instrument should be able to cope with a logging rate of 1 Hz for the beam luminosity and 0.1Hz for the bunch luminosity. By selecting a few bunches, it should be possible to log at the 1Hz rate. The actual logging rate of several data (average luminosity, bunch-by-bunch luminosity, etc) can be adjusted later to the actual needs.

5.12 POST-MORTEM ANALYSIS

The luminosity data does not seem essential for the understanding of beam losses. It can rather be used to crosscheck other beam data. It seems wise to foresee the recording of the average beam luminosity over the last minute (or 5 minutes) at a rate of 1Hz to be available in case of a dump.

The background data can be useful to diagnose issues local to one experiment, such as orbit drifts or oscillations. In case of a dump, the average beam backgrounds of the last 5 minutes should be available, sampled at a rate of 1 Hz.

6. MACHINE AND EXPERIMENT INFORMATION EXCHANGE

The information to be communicated between the LHC machine and experiments and the implementation of the link are discussed in the LHC Data Interchange Working Group (LDIWG) [19] and the LHC Experiment-Accelerator Data Exchange (LEADE) Working Group [20]. These communication links will be required to guide the interaction between the collider and experiments when operation of the LHC commences. Emphasis is placed on observables that can provide a measure of the LHC machine operating conditions for the experiments, and that can be used by the experiments to give feedback to the machine operation as well as to protect their detectors against damage from spurious operating conditions of the machine. The protection of the detectors against damage will be directly connected to the Machine Protection System as the information-exchange system discussed here is not meant to allow such functionality.

This chapter discusses the **subset** of exchanged information most relevant to this specification. Figure 1 shows the conceptual lay-out of the entities considered for data exchange.

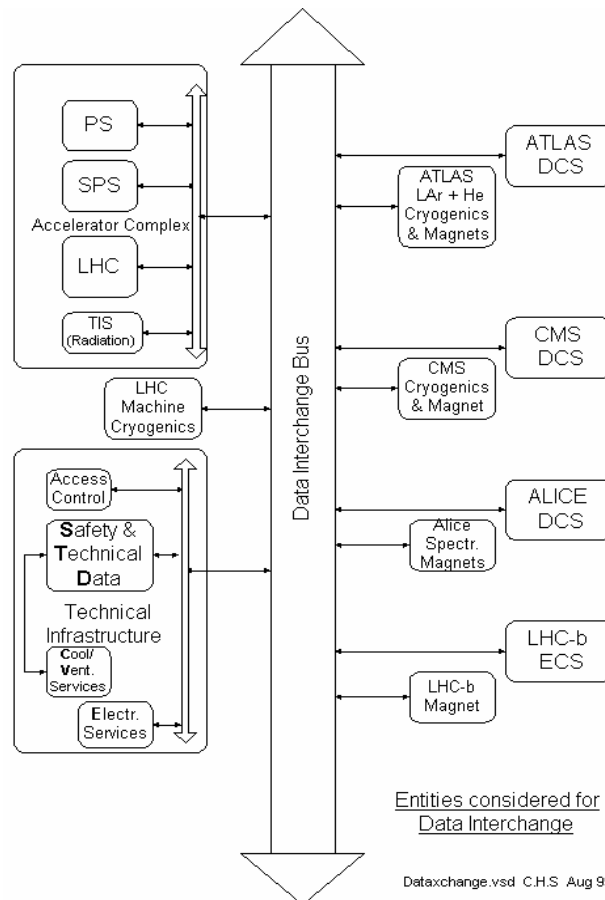

Figure 1: Entities considered for data exchange at the LHC

Details of the complete amount of information to be exchanged as well as the frequency may be found in Reference [19].

6.1 DATA FLOW: EXPERIMENTS TO MACHINE

6.1.1 CAPABILITIES OF THE BUS

Table 3: Data flow from experiments to machine

<i>Entity</i>	<i>Detail</i>
Spectrometer Magnets	Currents and polarity
Position of Moveable Detectors Components	LHCb Vertex Detector (VELO) TOTEM and potentially ATLAS Roman Pots
Background Measurements in detectors	Spatial and temporal distributions
Beam condition monitors	Standardized background monitors used as reference for machine tuning
Beam Characteristics	Vertex position (x,y,z) Luminous region
Absolute and Instantaneous Luminosity	Various sources for instantaneous (calorimeter currents, dedicated counters) TOTEM for absolute

The vertex position is measured in the reference frame of the experiment. A conversion to the machine reference frame shall be done before transmission. It will be based either on survey data measured during shut-downs or on continuous monitoring wherever available. The conversion strategy will be defined in the LEADE working group.

The relative luminosity can be measured from trigger rates and both the integral/average and bunch-by-bunch values will be provided. Transmission of the summary information from the experiments to the machine can be performed at a rate of 1 Hz. The bunch-by-bunch luminosity can be reported at least every minute during stable physics conditions. The expected accuracy is of the order of a few per cent. The same detectors are planned to measure the backgrounds and would deliver the data at the same rate.

6.1.2 DATA PROVIDED BY ATLAS/CMS

This is the data anticipated to be made available to the machine together with possible rates [26]. It is underlined in [26] to retain flexibility in the data-exchange system (e.g. in the number and choice of quantities to be exchanged, the production interval and hence the data rate).

Table 4: Data provided by ATLAS/CMS

<i>Producer</i>	<i>Measurements</i>	<i>Units</i>	<i>Production Volume (Bytes)</i>	<i>Production Interval (sec)</i>	<i>Data Rate (Bytes/sec)</i>
ATLAS/CMS	Total luminosity	$10^{34} \text{ cm}^{-2}\text{s}^{-1}$	4	1	4
ATLAS/CMS	Average rates	Hz	12	1	12
ATLAS/CMS	Luminosity per bunch	$10^{34} \text{ cm}^{-2}\text{s}^{-1}$	14256	60	238
ATLAS/CMS	Rates for individual bunches	Hz	42768	60	713
ATLAS/CMS	Position and size of luminous region (average over all bunches)	cm	24	600	0.04
ATLAS/CMS	Total per experiment				966

6.1.3 REQUIREMENTS FROM MACHINE LUMINOMETERS

Table 5: requirements from machine luminometers

<i>signal</i>	<i>Interval</i>	<i>reference</i>
Absolute luminosity	mn	Section 5.11
Vertex position	mn	Section 5.8
Backgrounds	≤ 1 s	Section 5.10

6.2 DATA FLOW: MACHINE TO EXPERIMENTS

Table 6: Data flow, machine to experiment

Measurement	units	Production Volume (Bytes)	Transmission interval	Expected Accuracy	Remarks
Total beam intensity	proton	8	~ 1 sec	1%	
Individual bunch intensities	proton	28,512	~ 1 min	5%	
Rms transverse beam sizes at IP's	mm	16	~ 1 sec	15%	Transported from IR4 to the IP's based on model or measured β -functions
Average bunch length	ps	8	~ 1 sec	1%	
Total longitudinal distribution	proton/bucket	285,120	~ 1 min		Will be able to detect ghost bunches at the 0.1% level of nominal
Average HOR & VER positions	μm	32	~ 1 sec	$50\mu\text{m}$	From the BPMs at Q1 either side of each IP
Luminosity b-by-b		28,512	~ 100 sec	1% relative	
Beam Loss	proton/s	80	~ 1 sec	Few % relative	Including monitors at TAS and low- β locations

In addition to the luminosity proper, the experiments need all data required to calculate it from the beam geometry and charge and the data to estimate the beam quality, e.g. the beam losses around the IP's. These data were discussed in the LEADE WG [20] and are summarized in Table 6.

In addition to the above information, a concise summary of the machine operating status (LHC page1), as has been the case for other accelerators, is required. This should be made available on TV monitors throughout CERN, via the WWW and on the data interchange bus.

7. FUNCTIONAL REQUIREMENTS

7.1 LAYOUT

Machine luminometers are needed in each of the four LHC experiments, on each side of the interaction points. They shall be as much as possible identical in ATLAS and CMS. Due to the different topologies in ALICE and LHCb, this requirement probably does not hold. The goal however remains of providing instruments which allows an easy comparison between IP's.

7.2 GEOMETRICAL ACCEPTANCE

Table 7: Topology of the interaction points. The nominal crossing angle is listed together with its maximum range of variation reachable with lower focusing or after an upgrade of the low- β quadrupoles.

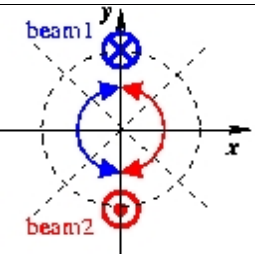
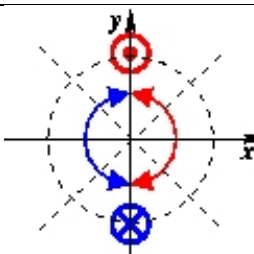
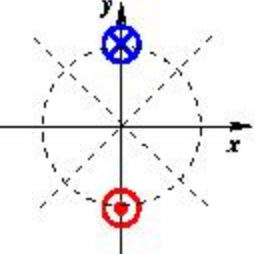
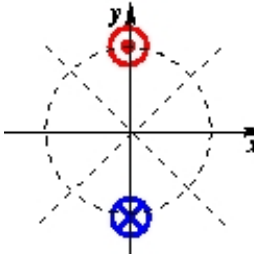
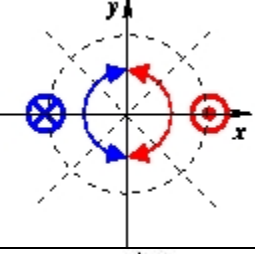
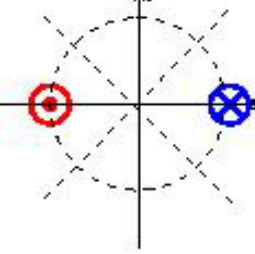
	<i>Beam crossing seen just upstream the IP along beam1 in the xy plane: the nominal positions are depicted by the symbols; the solid lines show an extended range valid for lower performance or upgraded low-beta quads)</i>	<i>Orientation of Xing plane (angle in the xy plane) degree</i>				<i>Range of 1/2 Xing angle (in the Xing plane) μrad</i>		
		<i>baseline</i>		<i>option</i>				
		<i>Beam 1</i>	<i>Beam 2</i>	<i>Beam 1</i>	<i>Beam 2</i>			
IP1 Atlas			+90	-90	+90 → +270	-90 → +90	$\pm [0 \rightarrow 200]$	
			-90	+90				
IP2 Alice			+90	-90			$\pm [0 \rightarrow 150]$	
			-90	+90				
IP5 CMS					+90 → +270	-90 → +90	$\pm [0 \rightarrow 200]$	
			180/0					
IP8 LHCb							$\pm [0 \rightarrow 285]$	
			0/180					

The geometry of the interacting beams is summarized in Table 7. The option is likely to be used at commissioning and for LHC upgrades.

7.3 SAMPLING FREQUENCY

For scenarios a,b,c,f,g (section 4.1) covering the first years of LHC running, the knowledge of the luminosity averaged over the bunches is expected to be sufficient for machine operation. However the LHC experiments require bunch-by-bunch data from the start of the LHC. For nominal and ultimate performance, a bunch-by-bunch measurement becomes necessary also for the machine operation. At all times, crosschecks of the bunch luminosities with the experiment detectors can be useful.

The sampling frequency shall thus be the proton bunch frequency, i.e. 40 MHz.

If this would turn out to be impossible, an acceptable degradation would consist in measuring the luminosity averaged over n consecutive bunches. To peak up the Pacman bunches, $n=15/k$, with $k \approx 1,2,3, \dots$

7.4 DYNAMIC RANGES

7.4.1 BEAM ENERGY

The nominal beam energy at which the luminosity is to be measured is 7 TeV but there are exceptions:

- Initial running possibly at a lower energy, e.g. 6 TeV,
- Some TOTEM runs at 900 GeV (section 4.1), possibly with ATLAS participation,
- Some TOTEM runs at 1.8 TeV, possibly with ATLAS participation,
- Some ALICE runs at 2.75 GeV (p-p and Pb-Pb) (section 4.3)

7.4.2 PARTICLE SPECIES

Table 8: *Ion species (from section 4.3)*

Baseline	p-p, Pb-Pb
Alice Programme	p-Pb, d-Pb, α -Pb, Ar-Ar
Alice options	d-d or α - α , another specie A amongst {N, O, Kr, Sn}, p-A or (d-A) or (α -A)

The baseline scenario and the developments and options are discussed in section 4.3

7.4.3 LUMINOSITY

Table 9: Total dynamic range

p-p	$1.25 \times 10^{26} \text{ cm}^{-2}\text{s}^{-1}$	$2.3 \times 10^{34} \text{ cm}^{-2}\text{s}^{-1}$
Pb-Pb	$4.0 \times 10^{23} \text{ cm}^{-2}\text{s}^{-1}$	$1.0 \times 10^{27} \text{ cm}^{-2}\text{s}^{-1}$

This dynamic range covers all scenarios in section 4.1. For the extreme scenarios with a single pilot bunch of protons, a luminosity decay by a factor of 2 instead of 5 (section 4.2.2) is assumed. It should be noted that 2 to 3 orders of magnitude on the low luminosity end are dedicated to the early commissioning. One might consider covering this range with the experimental ZDC's if this can help.

7.5 PRECISION, CALIBRATION AND INTEGRATION TIMES

7.5.1 RESOLUTION AND INTEGRATION TIME

The compilation of the anticipated uses points to two sub-ranges in the dynamic range:

Table 10: Requirements for the dynamic sub-ranges. The resolution in brackets applies for an automatic beam-beam overlap feedback.

Luminosity sub-range	particle	Resolution		integration time
		Beam structure	Luminosity	
$1.3 \times 10^{26} \rightarrow 1.0 \times 10^{28}$	p-p	beam	$\pm 10\%$	~ 1 mn
$1.0 \times 10^{28} \rightarrow 3.0 \times 10^{34}$	p-p	beam	$\pm 1\%$ (0.25%)	~ 1 s
$1.0 \times 10^{33} \rightarrow 3.0 \times 10^{34}$	p-p	bunch	$< \pm 10\%$ (machine)	~ 10 s
			$\pm 1\%$ (experiments)	~ 100 s
$1.0 \times 10^{24} \rightarrow 5.0 \times 10^{25}$	Pb-Pb	beam	$\pm 10\%$	~ 1 mn
$5.0 \times 10^{25} \rightarrow 1.0 \times 10^{27}$	Pb-Pb	beam	$\pm 1\%$ (0.25%)	~ 1 s
$5.0 \times 10^{25} \rightarrow 1.0 \times 10^{27}$	Pb-Pb	bunch	$\sim \pm 1\%$	~ 10 s

7.5.2 RELATIVE CALIBRATION

The relative calibration deals with possible variations of the proportionality factor between monitor signal and actual luminosity. This variation should be less than or equal to the resolution requested in Table 10 for the range of vertex parameters given in Table 11. For a constant crossing angle between the two beams, the trajectory of each beam may change due to machine tuning. We require the luminometer not to be sensitive to such changes within $15 \mu\text{rad}$ of the average beam direction for constant crossing angle.

Table 11: Tolerance on vertex parameters

Transverse tolerance (x,y)	± 3 mm
Longitudinal tolerance (s)	± 4.2 cm ($\geq \pm 20$ cm to 1m?)
Tolerance on half-crossing direction	$\geq \pm 15 \mu\text{rad}$

7.5.3 ABSOLUTE CALIBRATION

An absolute calibration is not strictly required but would be very helpful if it can be achieved (section 5.4). It puts no specific requirement if a single bunch is used with no crossing angle. With a crossing angle, the tolerance to the longitudinal vertex position ranges from ± 4 cm to about ± 1 m. A larger tolerance widens the conditions for performing scans.

7.5.4 ROBUSTNESS AGAINST BACKGROUND

The interaction rate monitor is exposed to various sources of background:

- beam-gas,
- beam halo hitting the upstream aperture limits,
- ghost bunches in 'un-allowed' buckets,
- debunched particles coasting in the machine. The expected maximum longitudinal density for the latter can be found in [21].

It is believed that an important handle on background issues is the installation of one luminometer on each side of each experiment.

An interesting proposal [14] is to shift the RF phase slightly for both beams. This would leave a few bunches without counterparts at the crossing and allow single rates to be measured turn by turn at the expense of insignificant loss in luminosity.

7.6 DATA FLOWS

The data flows to the experiments are specified in Table 6. The data flows to the control room are given in Table 12

Table 12: Data flows to the control room

<i>Data transfer</i>	<i>Rate</i>
Average luminosity for optimization (initial running and later)	≤ 1 Hz
Background for optimization	1Hz
Maximum logging rate of luminosity and background	1 Hz

8. DESIGN CONSTRAINTS

8.1 INB CONSTRAINTS

The luminometers and background monitors should conform to the INB regulations, guidelines and procedures: the LHC is indeed classified as an "Installation Nucleaire de Base (INB)" by the French Authorities. Within this context CERN has to establish traceability & waste management procedures and maintain a radiological and zoning system.

In order to meet these requirements, information such as: material content (drawings) and identification, sub-assemblies, etc..., shall be supplied by the Contractor and will be maintained in a CERN database.

CERN has created a set of procedures and conventions as part of the Quality Assurance System for LHC [22], which will also be used to facilitate these INB requirements. The relevant quality documents are listed below and shall be applied by the Contractor during the production, testing and assembly of components: "The Equipment Naming Convention" [23], "The LHC Part Identification" [24].

9. RELIABILITY, AVAILABILITY AND MAINTAINABILITY

The interaction rate monitor is inherently exposed to very high doses of radiation. Its design should be such as minimizing the requirement for human interventions. We recommend that the possible options (e.g. detection over the full x,y plane) be implemented from the start.

10. SAFETY AND REGULATORY REQUIREMENTS

The interaction rate monitor must meet the safety guidelines put forward by the CERN Technical Inspection and Safety Commission (TIS). TIS have issued safety documents in compliance with LHC-PM-QA-100 rev1.1, and the guidelines in these documents will be incorporated into the monitor design.

11. ACKNOWLEDGMENTS

We wish to thank M. Bozzo, K. Eggert and D. Macina who contributed to clarify the requirements. The detailed analysis of the specification by N. Ellis, P. Grafstrom, W. Witzeling, B. Turner, A. Ball and A. Morsch and their many sharp comments were of great help.

12. REFERENCES

1. J. Bosser et al., LHC Beam Instrumentation: Conceptual Design report, LHC Project Report 370, 2000.
2. A. Hofmann, J.P. Koutchouk, The beam-beam transfer function, ISR Performance Report, 27/1/1981.
3. E. Tsesmelis, private communication.
4. See web link "Beam Parameters - Design Performance" at the official web page of the LHC project (<http://lhc-new-homepage.web.cern.ch/lhc-new-homepage>).
5. https://edms.cern.ch/cedar/plsql/navigation.tree?cookie=1844784&p_top_id=1205733706&p_top_type=P&p_open_id=1671261951&p_open_type=P
6. LHCC Minutes: CERN/LHCC 2002-023 ,LHCC59, 16 August 2002
7. O. Bruning *et al.*, "A Beam Separation and Collision Scheme for IP1 and IP5 at the LHC for Optics Version 6.1", LHC Project Report 315, 1999.
8. O. Bruning *et al.*, "A Beam Separation and Collision Scheme for IP2 and IP8 at the LHC for Optics Version 6.1", LHC Project Report 367, 2000.
9. W. Herr, private communication, 13/12/2002.
10. 1st Luminosity Workshop, 9/12/2002, http://est-div-lea.web.cern.ch/est-div-lea/luminosity/1st_lumi_workshop.htm
11. S. Fartoukh, private communication, 2002.
12. W.C. Turner, "Instrumentation for the Absorbers in the Low-Beta Insertions in LHC", LBNL-42180, 1998.

13. A. Morsch, 'Van Der Meer Method for the Luminosity Measurements at the LHC', ALICE-INT-2003-004, 2003.
14. K. Potter in [10].
15. K Cornelis, Beam-beam effects in the SPS proton-antiproton collider, in CERN-SL-99-039 AP, 1999.
16. T. Limberg et al., Recent and past experiences with beam-beam effects at HERA, in CERN-SL-99-039 AP, 1999.
17. D. Sagan et al., A luminosity monitor using the coherent beam-beam interaction, PAC93, 1993.
18. J.P. Koutchouk, Requirements of beam dynamics on the alignment of the low- β insertions, LHC project Note 211, 2000.
19. <http://lhc-div.web.cern.ch/lhc-div/Controls/WG/LDIWG/Welcome.html>
20. LEADE 10th meeting, 12 may 2003, <http://cern.ch/lhc-data-exchange>
21. C. Fischer, Functional Specification "High Sensitivity Measurement of the Beam Longitudinal Distribution of the LHC Beams", LHC-B-ES-0005v1.0, <http://edms.cern.ch/document/328145>
22. <http://lhc-proj-qawg.web.cern.ch/lhc-proj-qawg/LHCQAP>
23. <https://edms.cern.ch/file/103369/1.0/LHC-PM-QA-204-00-10.pdf>
24. <https://edms.cern.ch/file/103551/1.0/Qap206.pdf>
25. A. Morsch, private communication, 6/1/2003.
26. N. Ellis, P. Grafstrom (ATLAS), W. Smith (CMS), memo to E. Tsesmelis, 15-5-2003.
27. LCC 32, 6-11-2002. <http://lhc.web.cern.ch/lhc/lcc/lcc.htm>
28. ATLAS Coll. Letter of Intent, "ATLAS forward10 detectors for luminosity measurement and monitoring", CERN/LHCC/2004-010.
29. A. Morsch, ALICE Luminosity and Beam Requirements, ALICE-INT-2001-10 ALICE Physics Performance Report Vol. I, CERN/LHCC 2003-049, Chapter 2.