

FILE COPY

CERN - DATA HANDLING DIVISION
DD/73/1
M. Benot
J.M. Howie
February, 1973

EVALUATION OF THE IMAGE IN A
SPOT FOCUSING ČERENKOV COUNTER

1. INTRODUCTION

In a Čerenkov counter, high-energy particles pass through a radiator and emit photons at an angle θ according to the usual Čerenkov relation

$$\cos \theta = \frac{1}{\beta n(\lambda)}, \quad (1)$$

where θ is the angle of emission of the photons with respect to the particle direction, β is the particle velocity relative to the velocity of light, and n is the refractive index of the radiator medium which is a function of the wavelength λ of the light. There is light emission when the β value of the particle is above a threshold β_T such that

$$\beta_T = \frac{1}{n}. \quad (2)$$

This relation is applied to threshold counters where the detection of this light allows one to select particles having a velocity $\beta > \beta_T$. When one wants to exploit a window of velocities one can use two threshold counters in anticoincidence. One can also make use (for well-collimated beams of particles) of differential or DISC Čerenkov counters. Here the light is focused onto an annular diaphragm, the opening width of which determines the desired window of velocities.

Several attempts have been made to devise a Čerenkov counter which can accept a diverging beam of particles. Such a detector has been designed at CERN¹⁾ for the case of detecting particles coming from a small volume in space, such as from a target. This detector uses conical or toroidal optics to focus the Čerenkov light of a particle with a given velocity β_0 into a small spot image. The concentration of the light yield simplifies the detection problems. For a particle with velocity $\beta \neq \beta_0$, a ring image is produced instead of a spot, the radius of the ring being related to the particle velocity. The position of the spot (or centre of the ring image) yields information on the angular coordinates of the particle.

The principle of the spot-focusing detector is illustrated in Fig. 1 in which the conical waves of the Čerenkov light are converted into plane waves, which can then be focused to a spot. The basic design parameters as well as the performances expected with such a detector have been presented elsewhere¹⁾. In this present paper we are particularly concerned with the derivation of the basic formulae which define the geometrical shape of the image produced by the detector.

The configuration of the detector is shown in Fig. 2. A spherical mirror is placed at a certain distance from the target, and the axicon is placed at the image of the target produced by this spherical mirror. A virtual image is formed in the focal plane of the mirror. A final real image can then be produced in the

plane of the electronic detection system by means of a conventional transfer lens, but for the purpose of this paper it is only necessary for us to consider the virtual image produced in the focal plane. In the present design, the axicon, which is used to produce the necessary bending of the rays and to reduce the chromatic dispersion of the Čerenkov light is, in fact, made up of a doublet of axicons. In the next section, formulae are derived which allow us to express the direction of the light vector leaving an axicon in terms of the direction of the incoming light vector. In Section 3.1 we derive some of the basic optical relations which are valid for our counter configuration, and in Section 3.2 we trace a general skew ray through the optical system and determine the equation of the image formed in the focal plane of the mirror. Throughout the analysis we have applied first-order theory, which assumes that paraxial and small-angle approximations are valid. Section 4 consists of a discussion of the properties of this image and finally in Section 5 we give some indication of the size of the optical elements needed for such a detector.

2. REFRACTION THROUGH AXICONIC SURFACES

Figure 3 shows the refraction of a light ray at a plane surface. The vectorial formulation of Snell's law is

$$n_2 \vec{V}_2 = n_1 \vec{V}_1 + \Gamma \vec{N} , \quad (3)$$

where \vec{V}_1 and \vec{V}_2 are, respectively, unit vectors along the incident and refracted rays at the boundary surface of two media with refractive indices n_1 and n_2 , and \vec{N} is the unit vector perpendicular to the surface. All vectors are oriented in the direction of the light. The quantity Γ is given by the equation

$$\Gamma = \left[n_2^2 \cdot n_1^2 + n_1^2 (\vec{V}_1 \cdot \vec{N})^2 \right]^{\frac{1}{2}} - n_1 \vec{V}_1 \cdot \vec{N} . \quad (4)$$

In the paraxial approximation

$$\Gamma = n_2 - n_1 , \quad (5)$$

and hence

$$n_2 \vec{V}_2 = n_1 \vec{V}_1 + (n_2 - n_1) \vec{N} . \quad (6)$$

We now consider a ray of light passing through an axicon (see Fig. 4). The axicon has refractive index n_1 and is immersed in a medium of refractive index n_0 . The angle of the axicon is α . For an axicon of small angle the paraxial approximation remains valid, and hence by applying Eq. (6) to the two surfaces in turn, we find

$$n_0 \vec{V}^* = n_0 \vec{V} + (n_1 - n_0) (\vec{N}_1 - \vec{N}_2) , \quad (7)$$

where \vec{V} and \vec{V}^* are unit vectors along the incoming and outgoing light rays, respectively, and \vec{N}_1 and \vec{N}_2 are the normals to the two surfaces.

For an axicon which is sufficiently thin we can apply the approximation

$$\vec{N}_1 - \vec{N}_2 \approx \alpha \vec{U}, \quad (8)$$

where \vec{U} is the unit vector along the direction joining the apex of the axicon to the point of intersection of the light ray with the axicon surface. Equation (7) then becomes

$$n_0 \vec{V}^* = n_0 \vec{V} + (n_1 - n_0) \alpha \vec{U}. \quad (9)$$

In the case of a doublet of axicons, we arrive at a similar relation, i.e.

$$n_0 \vec{V}^* = n_0 \vec{V} + [(n_1 - n_0) \alpha + (n_2 - n_0) \beta] \vec{U}, \quad (10)$$

where α and β are the angles of the two axicons, which have refractive indices n_1 and n_2 , respectively. The angles α and β are considered to be positive if the axicon becomes narrower as one approaches the outer edges, and negative otherwise. For example, in the axicon doublet shown in Fig. 4b, the angle α is positive, whilst the angle β is negative.

In practice, $n_0 \approx 1^*$ and it is convenient to write Eq. (10) in the following form:

$$\vec{V}^* = \vec{V} + d \vec{U}, \quad (11)$$

where

$$d = (n_1 - 1) \alpha + (n_2 - 1) \beta. \quad (12)$$

The angle d is the bending angle of the axicon doublet.

3. DERIVATION OF THE OPTICAL IMAGE

3.1 Basic optical relations

The layout of the counter is shown again in Fig. 5. The coordinate system is taken to be centred at the apex M of the spherical mirror. The Z -axis lies along the optic axis with Z positive in the direction of the target, and the Y -axis is vertically upwards as drawn in Fig. 5. The target, which we assume to be infinitely thin, is situated at position T and the axicon is placed at position T' , the image of T in the mirror.

It is useful to derive some formulae in the simple case of a particle travelling along the optic axis since, to first order, some of the results can be applied in a more general case.

*) In the present application n_0 corresponds to the radiator of the Čerenkov light which is a gas, and hence $n_0 \approx 1$.

Let the radius of the mirror be R. The distance of the target from the mirror is defined to be

$$Z_T = QR , \quad (13)$$

where Q is a multiplicative factor. The image point T' is then given by

$$Z_{T'} = mQR , \quad (14)$$

where

$$m = \frac{1}{2Q-1} . \quad (15)$$

The magnification of the image is -m.

We now consider a light ray emitted from a point L on the particle path at an angle θ to the axis. We suppose the light ray intersects the mirror at point B, and after reflection it intersects the axicon at point C.

$$\text{Let} \quad MB = \rho_M$$

$$\text{and} \quad T'C = \rho_A .$$

We suppose that the point L is defined by

$$Z_L = WR , \quad (16)$$

where W is a multiplicative factor always smaller than Q.

If L' is the image of L, we have

$$Z_{L'} = \mu WR , \quad (17)$$

where

$$\mu = \frac{1}{2W-1} . \quad (18)$$

Now using Eqs. (16)-(18) we can show that

$$\rho_M = WR\theta \quad (19)$$

and

$$\rho_A = m(Q - W)R\theta . \quad (20)$$

3.2 Equation of the image

Let us now consider a trajectory (D) emitted from a point S off axis on the target, such that

$$X_S = 0 , \quad Y_S = \delta , \quad Z_S = QR . \quad (21)$$

Let τ be the angle between (D) and the Z-axis, and ψ the angle which its projection in the X-Y plane makes with the X-axis. We suppose that (D) intersects the mirror at point E. To first order we have

$$X_E = QR\tau \cos \psi , \quad Y_E = \delta + QR\tau \sin \psi , \quad Z_E = 0 . \quad (22)$$

A light ray emitted from a point K on (D), where

$$Z_K = WR , \quad (23)$$

at an angle θ to the trajectory, intersects the mirror at point G and after reflection appears to come from the point K' , the image of K. The point K' is situated on the line (D') , the image of (D). From Eqs. (22) and (23) we deduce that the coordinates of the point K are given by

$$X_K = (Q - W)R\tau \cos \psi , \quad Y_K = \delta + (Q - W)R\tau \sin \psi , \quad Z_K = WR , \quad (24)$$

and hence from Eqs. (16) and (17) we have for the point K'

$$\begin{aligned} X_{K'} &= -\mu(Q - W)R\tau \cos \psi \\ Y_{K'} &= -\mu\delta - \mu(Q - W)R\tau \sin \psi \\ Z_{K'} &= \mu WR . \end{aligned} \quad (25)$$

The line (D') intersects the axicon at point S' , the image of S in the mirror. Hence

$$X_{S'} = 0 , \quad Y_{S'} = -m\delta , \quad Z_{S'} = mQR . \quad (26)$$

We suppose that the light ray from K intersects the axicon at point P. To first order we may assume that

$$EG = \rho_M$$

and

$$S'P = \rho_A ,$$

where ρ_M and ρ_A are given by Eqs. (19) and (20). If we let ω be the angle which the line EG makes with the X-axis, then we can deduce the coordinates of the points G and P, i.e.

$$X_G = QR\tau \cos \psi + WR\theta \cos \omega , \quad Y_G = \delta + QR\tau \sin \psi + WR\theta \sin \omega , \quad Z_G = 0 \quad (27)$$

and

$$X_P = \rho_A \cos \omega , \quad Y_P = -m\delta + \rho_A \sin \omega , \quad Z_P = mQR . \quad (28)$$

From Eqs. (27) and (28) we can compute the components of the vector \vec{GP} , the direction of the light ray falling on the axicon. To first order, the length of the vector GP is given by

$$GP \sim MT' = mQR . \quad (29)$$

Let \vec{V} be the unit vector in the direction \vec{GP} ; then the components of \vec{V} , to first order, are found to be

$$\begin{aligned} V_x &= -\frac{\theta \cos \omega}{\mu} - \frac{\tau \cos \psi}{m} \\ V_y &= -\frac{2\delta}{R} - \frac{\theta \sin \omega}{\mu} - \frac{\tau \sin \psi}{m} \\ V_z &= 1 \end{aligned} \quad (30)$$

The deviation of the ray falling on the axicon doublet is given by Eq. (12) and the direction of the light ray after passing through the axicon is given by Eq. (11). The vector \vec{U} in Eq. (11) is the unit vector in the direction $\vec{T'P}$. From the coordinates of the points T' and P we deduce that

$$T'P^2 = \rho_A^2 + m^2\delta^2 - 2m\delta\rho_A \sin \omega . \quad (31)$$

Let us assume that

$$\rho_A \gg |m\delta| , \quad (32)$$

then

$$T'P = \rho_A \left(1 - \frac{2m\delta}{\rho_A} \sin \omega \right)^{\frac{1}{2}} . \quad (33)$$

Hence we find

$$\begin{aligned} U_x &= \cos \omega + \frac{m\delta}{\rho_A} \cos \omega \sin \omega \\ U_y &= \sin \omega - \frac{m\delta}{\rho_A} \cos^2 \omega \\ U_z &= 0 . \end{aligned} \quad (34)$$

Now by substituting the vector components for \vec{V} and \vec{U} , given by Eqs. (30) and (34), in Eq. (12) we obtain the unit vector \vec{V}^* in the direction of the outgoing ray; i.e.

$$\begin{aligned} V_x^* &= \cos \omega \left(d - \frac{\theta}{\mu} \right) + \frac{dm\delta}{\rho_A} \cos \omega \sin \omega - \frac{\tau \cos \psi}{m} \\ V_y^* &= \sin \omega \left(d - \frac{\theta}{\mu} \right) - \frac{dm\delta}{\rho_A} \cos^2 \omega - \frac{\tau \sin \psi}{m} - \frac{2\delta}{R} \\ V_z^* &= 1 . \end{aligned} \quad (35)$$

The axicon doublet in our system bends the light ray and reduces the chromatic dispersion of the Čerenkov light without changing (to first order) the axial position of the focal plane, which thus remains the focal plane of the mirror. Our image point (X_F, Y_F) is therefore the point of intersection of the vector \vec{V}^* with the focal plane, i.e. with the plane $Z = R/2$. We find

$$\begin{aligned} X_F &= \frac{R}{2} \left(\theta - \frac{d}{2Q-1} \right) \cos \omega - \frac{d\delta \sin \omega \cos \omega}{2\theta(2Q-1)(Q-W)} + \frac{R\tau \cos \psi}{2} \\ Y_F &= \frac{R}{2} \left(\theta - \frac{d}{2Q-1} \right) \sin \omega + \frac{d\delta \cos^2 \omega}{2\theta(2Q-1)(Q-W)} + \frac{R\tau \sin \psi}{2} \end{aligned} \quad (36)$$

4. PROPERTIES OF THE IMAGE

If we let

$$r = \frac{R}{2} \left(\theta - \frac{d}{2Q-1} \right) \quad (37)$$

$$l = \frac{d\delta}{2\theta(2Q-1)(Q-W)} \quad (38)$$

and

$$\Delta = l \cos \omega, \quad (39)$$

then Eq. (36) becomes

$$\begin{aligned} X_F &= r \cos \omega - \Delta \sin \omega + \frac{R\tau \cos \psi}{2} \\ Y_F &= r \sin \omega + \Delta \cos \omega + \frac{R\tau \sin \psi}{2}. \end{aligned} \quad (40)$$

As the angle ω varies from 0 to 2π , Eq. (40) defines a closed curve. This curve is drawn in Fig. 6 as the curve ρ^* . The circle denoted by ρ is the degenerate curve obtained when $l = 0$, i.e. when the target size $\delta = 0$. This looped curve is, in fact, one of the geometrical curves discovered by Pascal and is known as the "Limaçon de Pascal". The loop degenerates into a cusp when $l \leq r$.

The condition which we introduced into the analysis in Eq. (32) can also be written as

$$\frac{\delta}{R\theta} \ll Q - W. \quad (41)$$

This relation means that we should not allow $Q - W$ to become small. In practice this means that to avoid large aberrations in the image we should only accept light rays that are emitted after a certain distance from the target, and this requirement is, in fact, included in the design of the counter.

From Eq. (40) we see that spot focusing occurs when $r = 0$, i.e. when

$$d = (2Q - 1) \theta. \quad (42)$$

Thus for one particular Čerenkov angle θ_0 [which from Eq. (1) implies one particular particle speed β_0], the axicon can be designed to produce a spot image. For other particle speeds the image is basically a circle of radius

$$r = \frac{R}{2} \left(\theta - \frac{d}{2Q-1} \right) = \frac{R}{2} \left(\theta - \theta_0 \right), \quad (43)$$

with some aberration depending on the value of the ratio $1/r$.

The radius r of the circle allows one to make an estimate of the value of θ and hence the particle speed β , whilst the centre of the circle which has coordinates

$$\left(\frac{R\tau \cos \psi}{2}, \frac{R\tau \sin \psi}{2} \right)$$

allows one to estimate the divergence angle τ of the particle. More details of the expected accuracy of these determinations are contained in the paper already cited¹⁾.

5. SIZE OF THE OPTICAL ELEMENTS

5.1 The mirror

The mirror should be designed to collect all the light from any particle which the counter is supposed to detect. The size of the mirror then depends on the following quantities:

- i) the distance between target and mirror = QR ;
- ii) the maximum divergence angle of a particle τ_{\max} ;
- iii) the Čerenkov angle θ_0 ;
- iv) the length of the counter L .

In effect, L is the length of the particle trajectory over which the emitted light is to be used, i.e.

$$L = W_{\max} R. \quad (44)$$

If R_{mir} is the physical radius of the mirror, then, ignoring the size of the target,

$$R_{\text{mir}} \geq QR \tau_{\max} + W_{\max} R \theta_0. \quad (45)$$

In practice, when designing a counter of this type, the quantity which one is most likely to want to fix is the average number N of photoelectrons which reach the detector system. This number N is usually expressed by the following relation:

$$N = AL\theta_0^2, \quad (46)$$

where A is a parameter depending on the light transmission through the counter optics and the performance of the photocathode of the detector system. Combining Eqs. (44) and (46) we can express R as

$$R = \frac{N}{A\theta_0^2 W_{\max}}, \quad (47)$$

and substituting this expression for R in Eq. (45) gives

$$R_{\text{mir}} \geq \frac{N}{A\theta_0^2} \left(\frac{Q}{W_{\max}} \tau_{\max} + \theta_0 \right). \quad (48)$$

5.2 The axicon

In Eq. (20) we worked out the distance ρ_A between the point where the light ray crosses the axicon and the optic axis, for a particle travelling along the axis.

If we ignore the size of the target, then the physical radius of the axicon should be at least equal to the maximum value of ρ_A , i.e.

$$R_{\text{axi}} \geq \frac{QR\theta_0}{2Q - 1}. \quad (49)$$

It is interesting to note that the size of the axicon is independent of the divergence angle τ . As we did for the mirror we can also express the radius in terms of N; i.e. using Eq. (4) we have

$$R_{\text{axi}} \geq \frac{QN}{A\theta_0^2 (2Q - 1) W_{\max}}. \quad (50)$$

REFERENCE

- 1) M. Benot, J.M. Howie, J. Litt and R. Meunier, A spot-focusing Čerenkov counter for the detection of multiparticle events at high energies. To be published in Nuclear Instruments and Methods (submitted in February 1973).

Figure captions

- Fig. 1 : Ray diagram illustrating the basic principles of a spot-focusing detector.
- Fig. 2 : A possible layout for a spot-focusing detector.
- Fig. 3 : Refraction of light at a surface.
- Fig. 4a : Refraction of light through an axicon of small angle α .
- Fig. 4b : An axicon doublet.
- Fig. 5 : Detailed tracing of a skew light-ray through the optical system of the spot-focusing detector.
- Fig. 6 : Image shapes in the focal plane of the mirror. The point S is the spot image for particles having a velocity β_0 for which the counter is "set". For particles with $\beta \neq \beta_0$, the curve ρ^* is formed for particles leaving the target at a finite distance from its centre. This curve degenerates into the circle ρ for particles originating from the centre of the target.

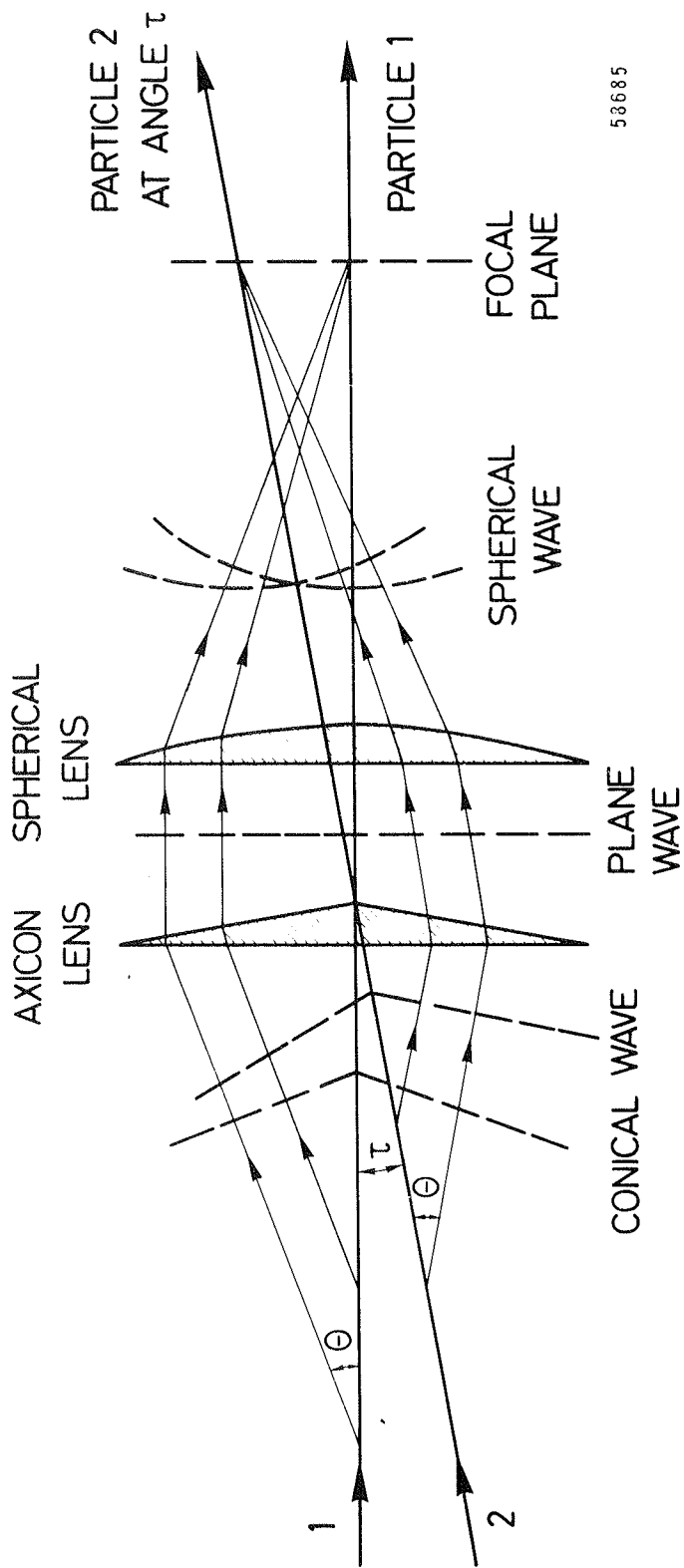

58685

Fig. 1

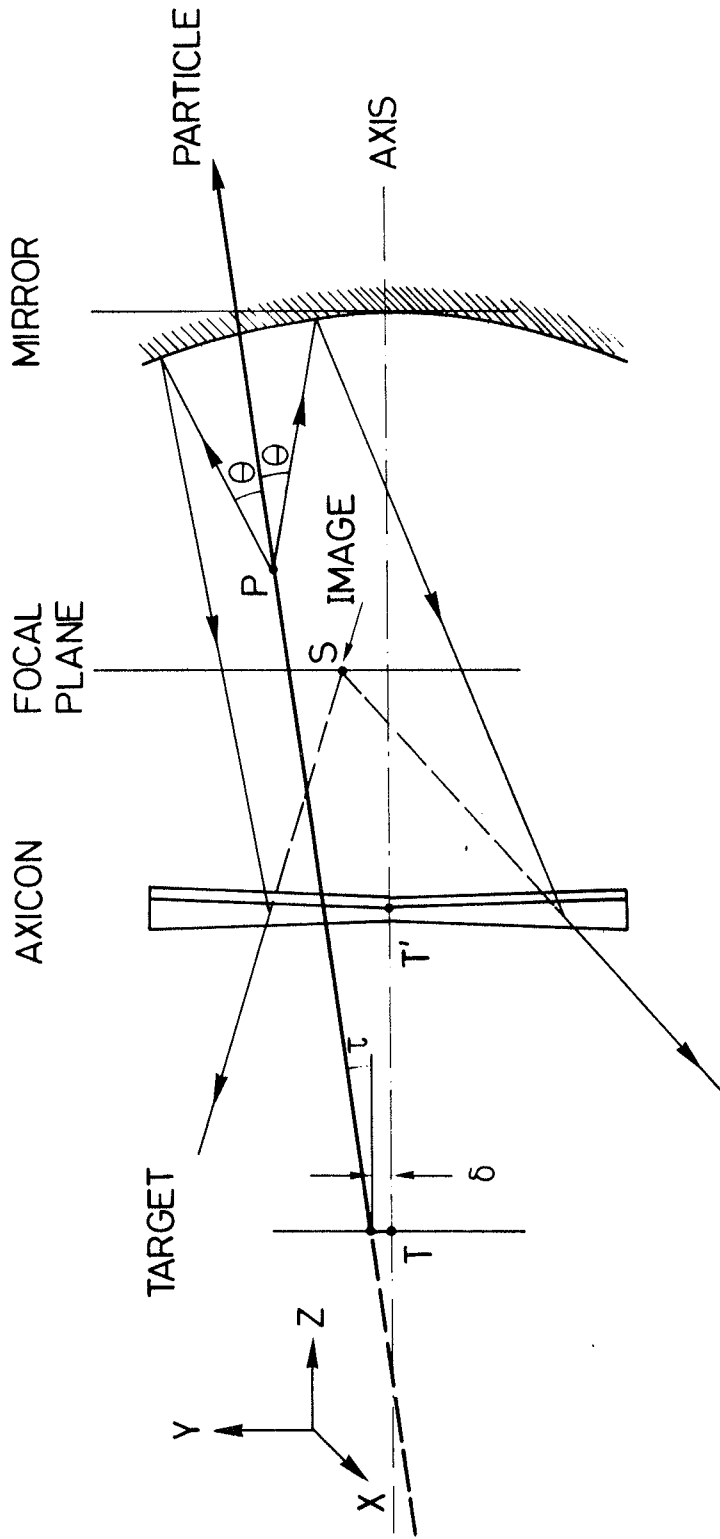

Fig. 2

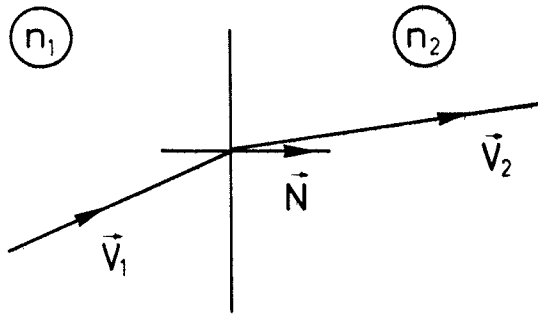
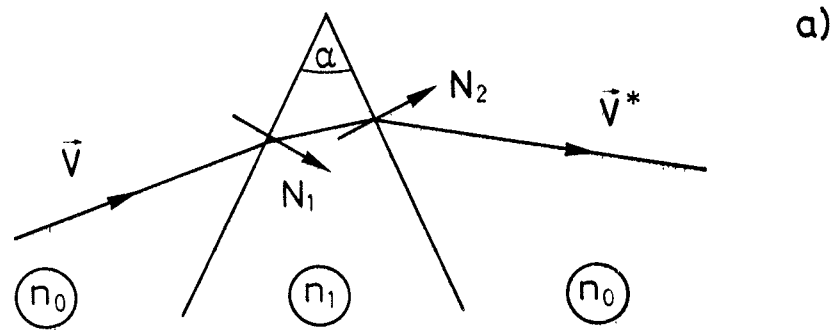
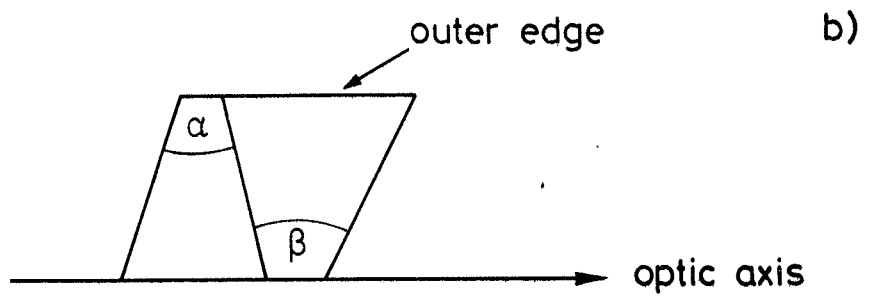

Fig. 3



a)



b)

Fig. 4

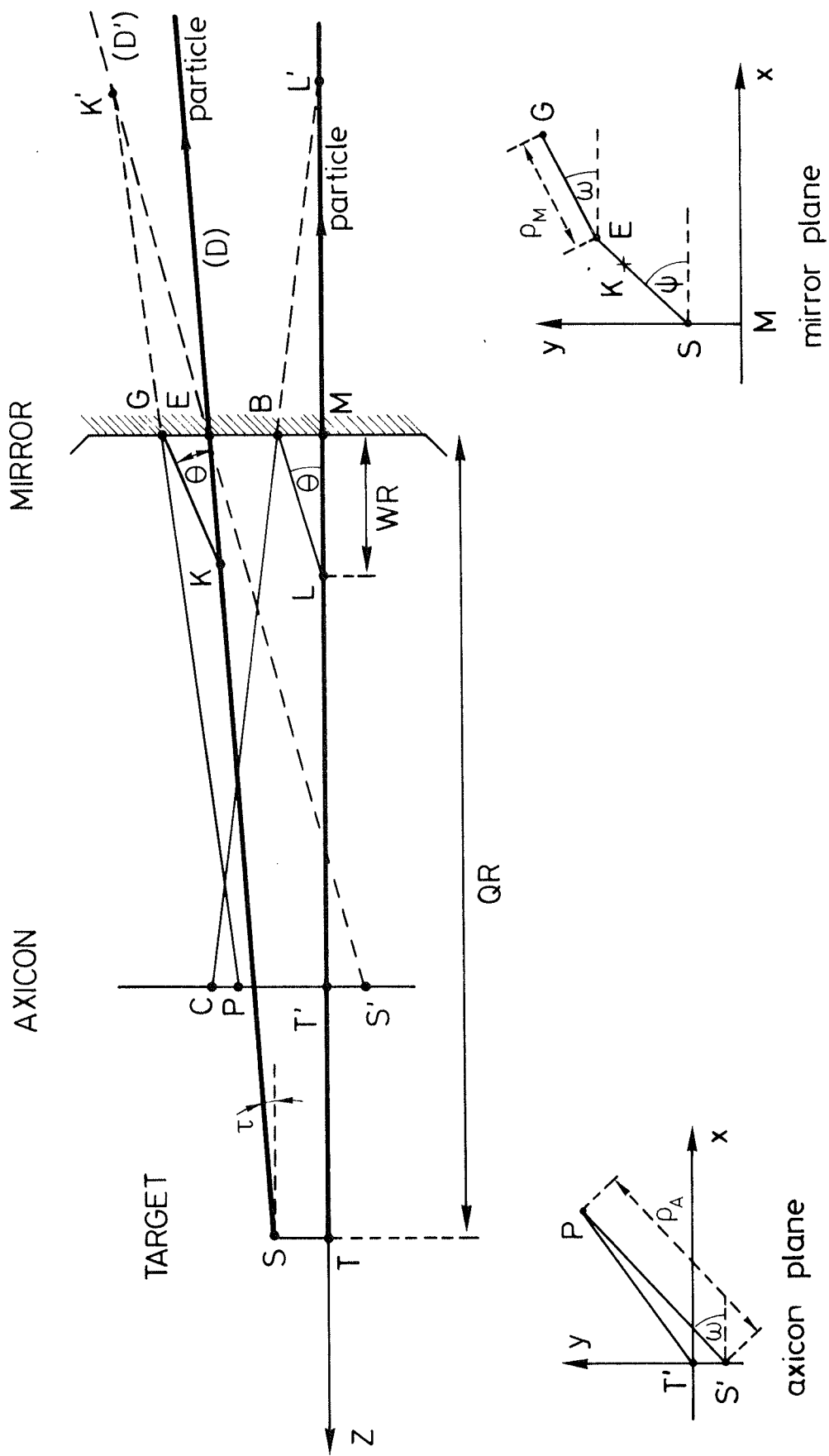
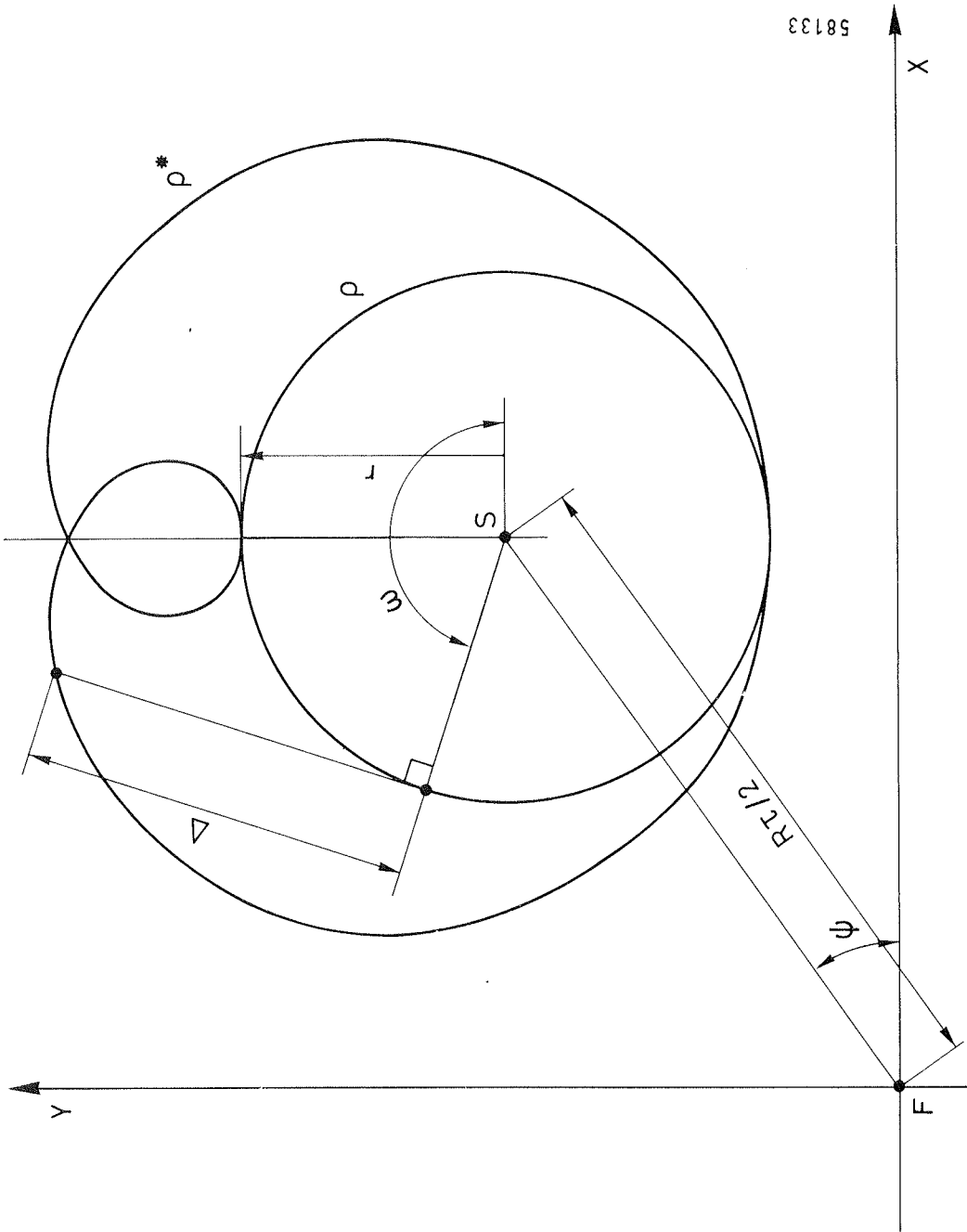

Fig. 5



58133

Fig. 6