

SPS IMPROVEMENT REPORT No. 187Beam Television Monitor (BTV) as Profile Detector

G. Ferioli, J. Mann

1. Introduction

BTV monitoring offers fast diagnostics and is intensively used for steering proton beams. However beam spots and therefore absolute sizes are only approximate indications because of various inherent limitations in the system.

Since beam profiles have been successfully measured with the SPS synchrotron light detectors^{1,2)} it was only another logical step to apply similar techniques to our standard BTV-monitors. Preliminary experiments in the ISR³⁾ and at the SPS have shown that a light detection system working even at very low intensities could be made operational.

2. The layout

To check the method of taking beam profiles directly from light spots, which are created when high energy protons traverse thin luminescent screens, we had to study three main characteristics:

- linearity of the detector
- fast response of the screen
- absence of saturation effects in the screens.

In the West extraction area a special vacuum tank (pos. 610227) makes it possible to install a BTV detection system. Three different light emitting screens were installed under vacuum and separated from atmosphere by a standard viewing port. The light detector consisted of a radiation resistant objective ($f = 50 \text{ mm } 1:2.8$) mounted on a conventional camera box which contains a special vidicon. The screen - objective working distance was 680 mm which gave a magnification of -12.6 . The screens were focused on to the face-plate of the special vidicon (stop number F:11) such to get an image of the beam spots. The layout furthermore provides 2 SEM grid-monitors, namely a BSG (610142) of resolution $H = 2.5, V = 0.8 \text{ mm}$, - 22 m upstream and a BSG (610317) of resolution $H = 1.5, V = 0.8 \text{ mm}$, - 35 m downstream for comparison of beam profiles.

3. The Light Detector

To cope with the very large variations in extraction intensities (typical values during our measurements were: $I_p \text{ min} \sim 6 \times 10^{10}$ ppp for a slow extraction calculated for 40 ms time interval; $I_p \text{ max} \geq 8.5 \times 10^{12}$ ppp) and also with the various sensitivities of the luminescent screens, a SIT^{*}) vidicon has been selected. The tube has individual gain control with a range of 16000.

4. Electronics

The block diagram is given in fig. 1. The camera allows the light spot to be displayed on a receiver (fig. 2). For the analysis of this image the camera was modified and a certain number of electronic circuits has been developed⁴⁾. The system allows fast digitization and memorisation of the spot (one sample every 130 ns) by an ADC (8 bits) and a memory of 10000 x 8 bits arranged in 100 rows and columns corresponding to 100 odd or even TV-lines and 100 samples along each line. The content of each position in the memory is added into an accumulator according to the lines and columns - the integral profile vertically and horizontally is thus obtained.

A certain number of profiles can be stored in the memory for computer processing (fig. 3).

5. Results

The SPS cycle makes it possible with increasing energy of the protons to extract various intensities during different durations. This particular feature has been used to test the light emitting screens in various working conditions.

Starting from a typical light spot (fig. 2), as it may be currently observed in the MCR the corresponding profiles can be derived. The vertical profiles are shown below and the parameters given.

*) Silicon Intensifier Target

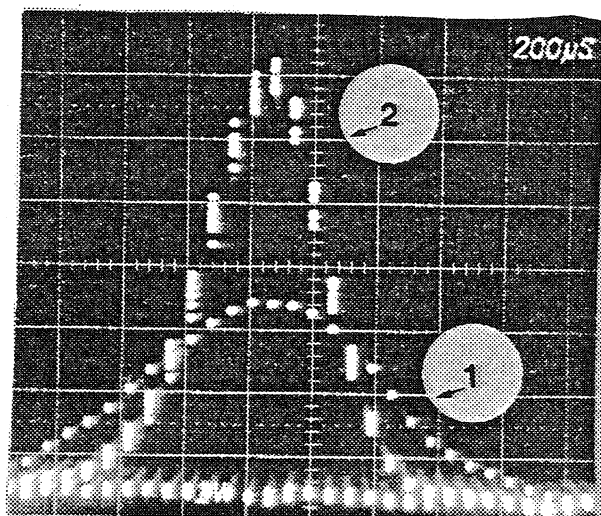
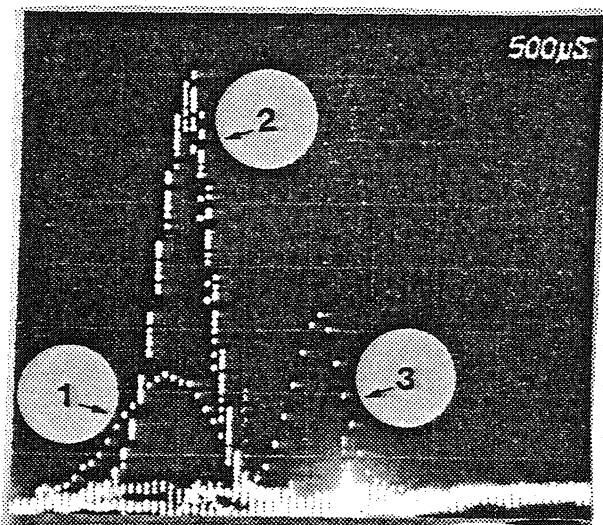

- | | | |
|-----------------------------------|-----------------------------------|---|
| (1) extr.FE1 duration 2.4 μ s | $I_p \sim 1.5 \times 10^{11}$ ppp | (1) extr.FE1 $I_p = 1.5 \times 10^{11}$ ppp |
| (2) extr.SE2 " 2.2 s | $I_p \sim 5 \times 10^{11}$ ppp | (2) extr.SE2 $I_p = 5 \times 10^{11}$ ppp |
| (3) extr.FE2 " 2.4 μ s | $I_p = 1.5 \times 10^{11}$ ppp | NB. Spill structure of slow extraction! |

Measurements of beam profiles as a function of (a) screen material and also (b) extraction types have been carried out by making comparisons with conventional SEM-grid recordings. Fig. 4 and 5 show some of the typical profiles obtained with screen 1. Similar results have been recorded for all screens and extraction types. Furthermore some quantitative results which are deduced from the curves of fig. 4 and 5 are summarized below.

Extraction Mode	Duration (s)	$\Sigma_{\text{screen 1}}$	$I_p \times 10^{11}$ ppp	$\frac{\Sigma}{I_p \times 10^{11}}$	FWHM (mm)	
					Vert.	Horiz.
SE1	50×10^{-3}	15940	3.1	5142	4	11.2
SE2	2.25	3406	0.62*)	5493	2.1	9.8
SE3	50×10^{-3}	6074	1.2	5061	2.3	9
FS4	3×10^{-3}	18970	30	632**)	3.6	8.6

*) I_p taken for time slices of 40 ms
 **) to avoid saturation the electronic gain was set a factor 8 lower than in the other cases. By applying the same gain a value similar to that for ratio Σ/I_p was found (5056).

A meaningful comparison between the profiles given by the screen and the two grids has been made in the vertical plane, where the profiles are gaussian, and for at 400 GeV fast extraction where the secondary emission monitors were sensitive enough.

Monitor	β_V	$L_V = \text{FWHM in mm}$		
		measured values		$L_V * \left(\frac{\beta}{\beta_{610142}} \right)^{1/2}$
BSG-V 610142	50	3.4	3.2	3.3 (mean)
SCREEN 1 610227	66	3.8	3.6	3.8
BSG-V 610317	73	3.6	4.0	4.0

The light production per screen-type, i.e. the relative number of photons emitted per traversing proton was also investigated. Table 1 shows the results of our measurements and the general characteristics of the screens. Good agreement between already known data and the experimental results may be seen.

In view of future pp experiments an estimate of the minimum number of protons detectable has been made. Detection of better than 5×10^8 ppp with screen 1 and 2.5×10^7 ppp with screen 3 can be expected by using the maximum gain available and reducing the stop-number to F:4. These minimum intensities can still be reduced by at least a factor 15 with the use of an ISIT*) tube which has been used recently for synchrotron light detection.

According to the typical persistence characteristics of the SIT-tube a remanent signal of 10% to 25% (depending on the light level) can be expected after 40 ms. Measurements carried out with all screens indicated no noticeable increase in persistence.

6. Conclusions

The measurements described in this paper were carried out in the very last days of SPS operation 1980 i.e. just before the long shutdown. A certain lack of precision due to low statistics has therefore to be accepted - but nevertheless the results obtained are fully satisfying our expectations.

Simultaneous profile measurements from one shot in the horizontal and vertical planes with a spatial resolution of 0.375 mm have been obtained. Better resolution is likely with other optics. With the gain control facility a range of 3000 can be used (in practice we assume a signal to noise ratio of 5:1 for obtaining correct beam profiles). No saturation effects in the screens have been observed. Very low intensities can be detected with good linearity. The system provides visualisation of profiles via CRT-display in real time. Future measurements in conjunction with a miniscanner (BBS) will certainly improve the results in respect to determine the most suitable screen for real beam size.

*) Intensifier Silicon Intensifier Target.

Beam blow up due to Coulomb scattering at energies above 100 GeV/c can be ignored. For lower energies the thickness of the screen can still be reduced, so that the effective mass would be only a factor 2 higher than for a standard BSG (0.032 g/cm^2). Because of the limited use damage due to very high proton fluxes can be avoided.

Acknowledgements

We are grateful for the support given by J. Bosser and L. Burnod, and to J. Camas who mounted the detector.

REFERENCES

1. SPS Improvement Report No. 165, 17 Oct. 1979.
2. R. Bossart et al., Proton beam profile monitor using synchrotron light, Proceedings XIth Int.Conf. on High Energy Accelerators, CERN, July 7-11, 1980.
3. ISR Performance Report Run 1091 26 GeV/c, RZ, 3rd March 1980.
4. J. Bosser, G. Ferioli, Beam profile acquisition by fast digitizing techniques. In preparation.
5. J. de Vries, J. Mann. Unpublished work (1978).
6. C.D. Johnson, CERN Technology Note B20, April 1974.
7. K.H. Kissler, BTV detectors, LAB.II/BT, August 1974.

Table 1

Parameter	Screen No.			Remarks
	1	2	3	
Name	Quartz	Glass-scintil.	Alumina	
Chemical composition	SiO ₂	Glass + Li ₂ O	Al ₂ O ₃ + Cr ₂ O ₃	
Density (g/cm ³)	2.2	2.06	3.85 - 3.92	
Thickness (mm)	0.5	1.0	1.0	
Ef. length (g/cm ²)	0.16	0.29	0.55	
Decay time (ns)	very fast ¹	<75	?	
λ peak (nm)	blue	395	red	
Relative sensitivity	1	5	50	theoretical ²
"	1	1.8*	23.4*	measured 1st series
"	1	2.4*	23.0*	measured 2nd series
"	-	1	10	theoretical ²
"	-	1	13.2	measured 1st series
"	-	1	9.8	measured 2nd series

1 used as Cerenkov radiator (ref. 5)

2 see ref. 6 and 7

* NB. The quartz plate which was used in our measurements was transparent and had a surface mirror deposit on its beam outlet side; therefore a combined effect of Cerenkov-radiation and scintillation can be expected. An opaque quartz plate would have given less signal than in the above case - an increase of the ratios of about a factor 2 seems realistic.

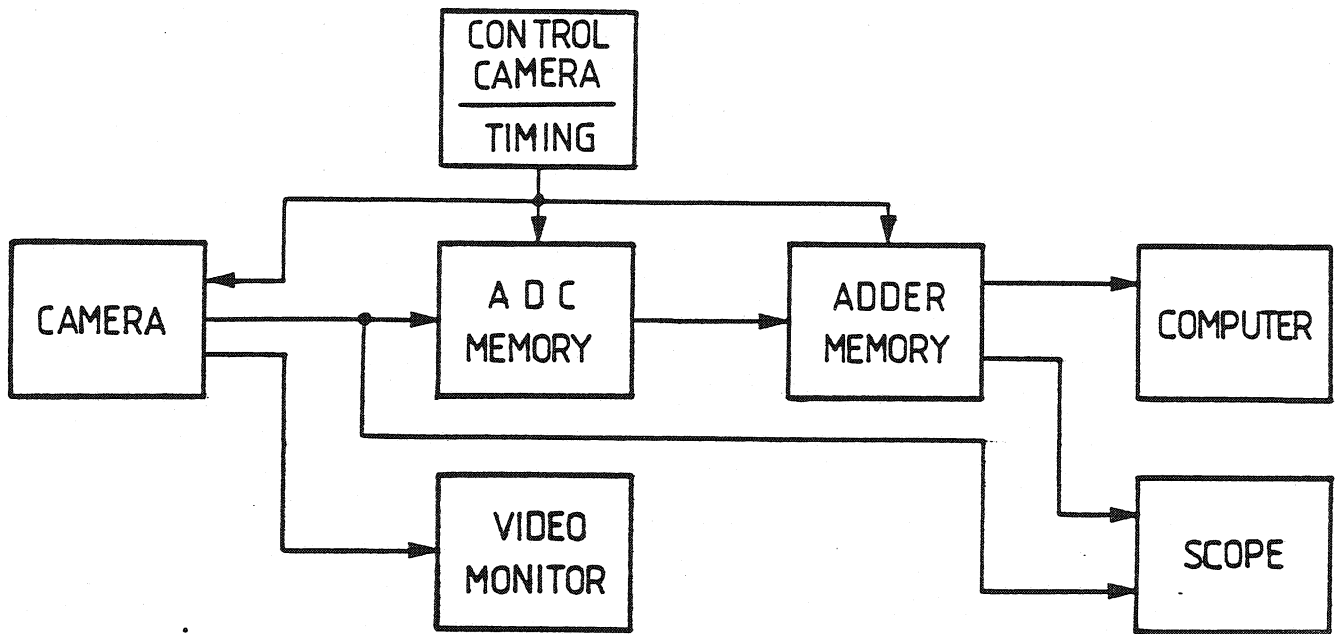

Fig. 1 BLOCK DIAGRAM

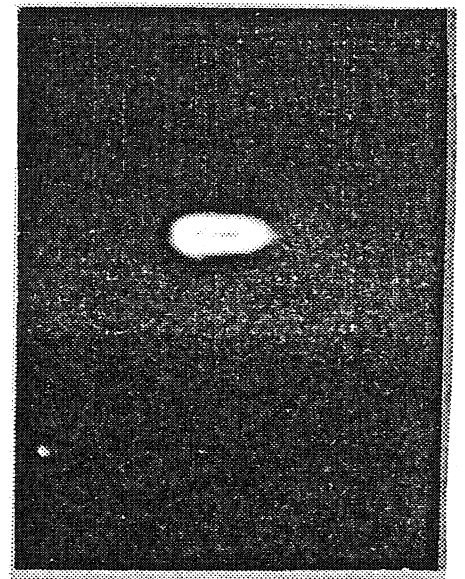

Fig. 2
VIDEO MONITOR DISPLAY
SE 2

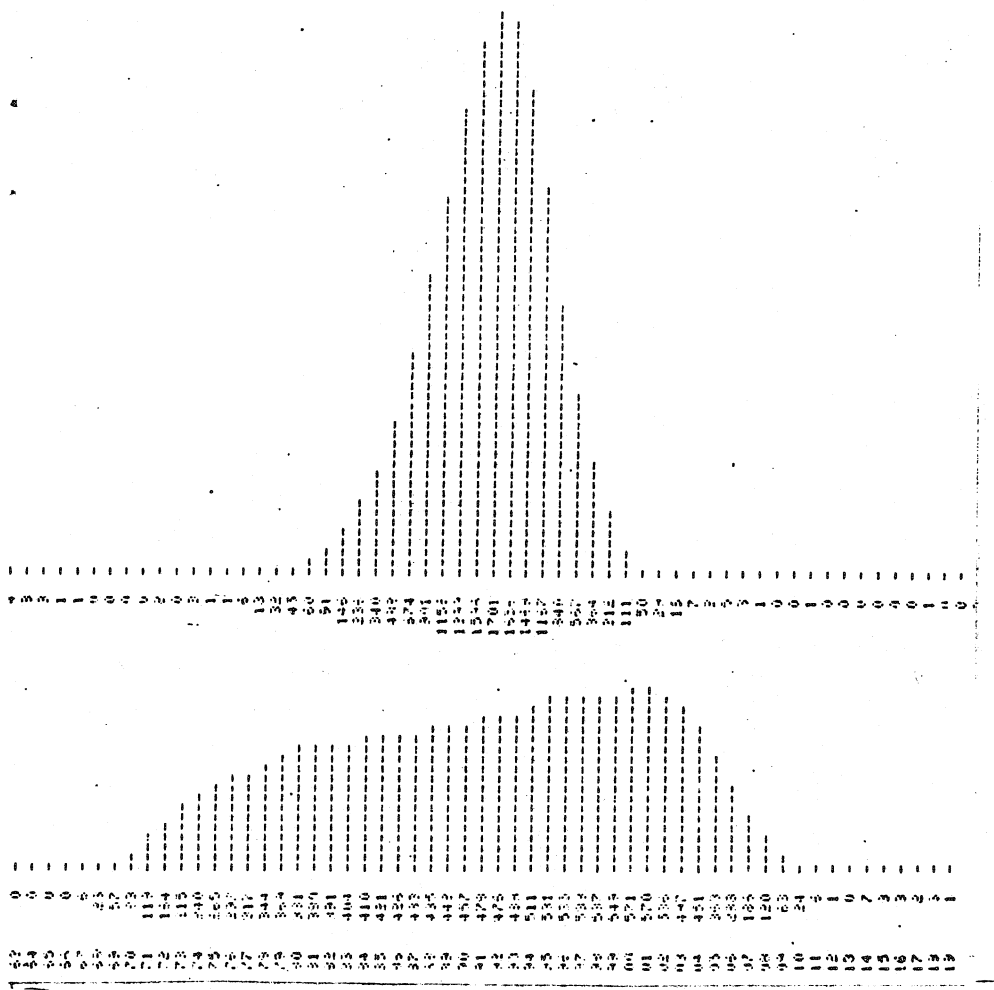

Fig. 3
VERTICAL AND HORIZONTAL PROFILE _ SE 2

FIG. 4

Vertical beam profiles

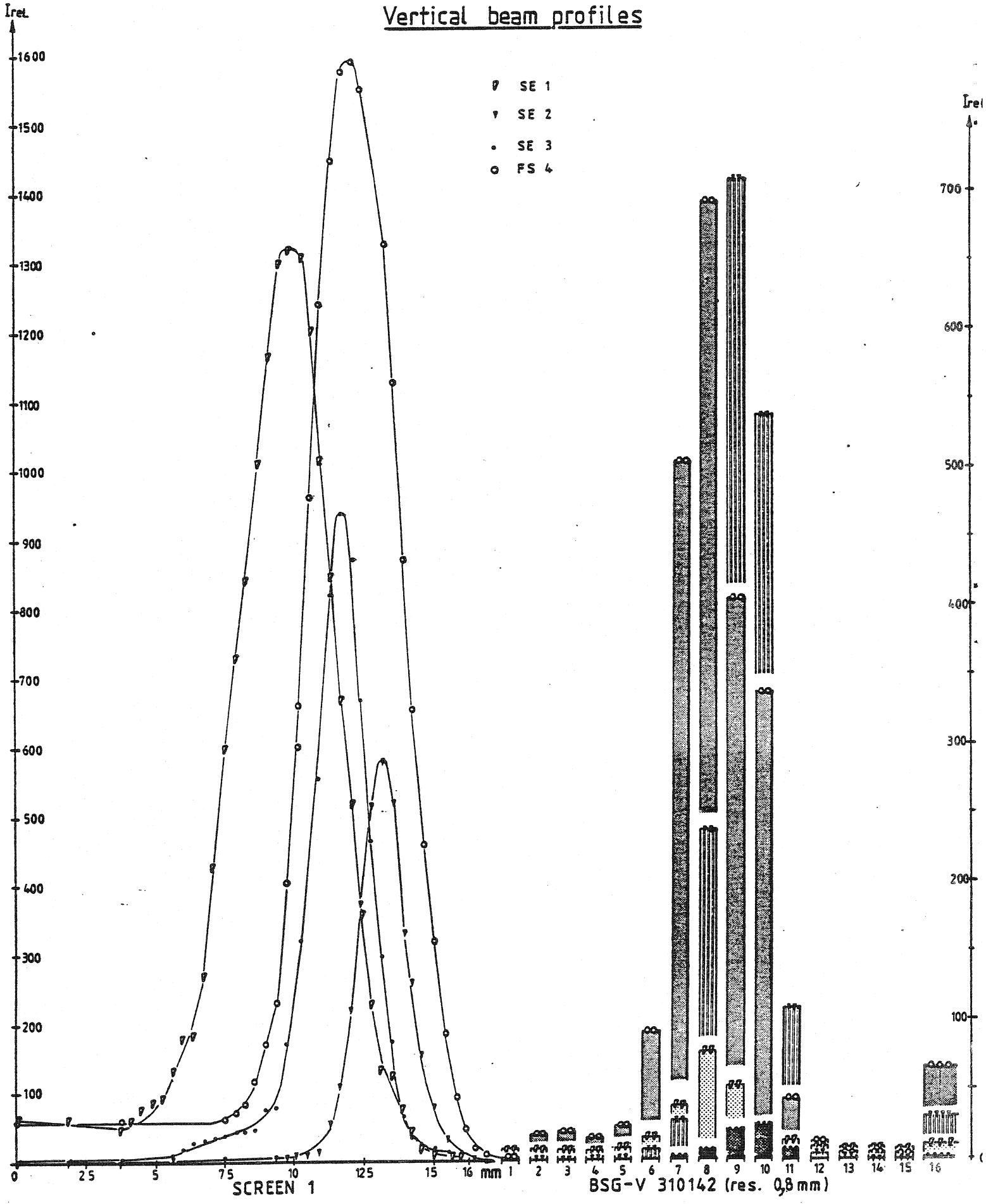

FIG. 5

Horizontal beam profiles

- SE 1
- ▽ SE 2
- SE 3
- ◊ FS 4

