

Porcine Hemagglutinating Encephalomyelitis Virus and Respiratory Disease in Exhibition Swine, Michigan, USA, 2015

Joshua N. Lorbach,¹ Leyi Wang,¹
Jacqueline M. Nolting, Madonna G. Benjamin,
Mary Lea Killian, Yan Zhang, Andrew S. Bowman

Acute outbreaks of respiratory disease in swine at agricultural fairs in Michigan, USA, in 2015 raised concern for potential human exposure to influenza A virus. Testing ruled out influenza A virus and identified porcine hemagglutinating encephalomyelitis virus as the cause of influenza-like illness in the affected swine.

The commingling of pigs and humans at agricultural fairs has been responsible for most zoonotic influenza A virus (IAV) cases over the past 5 years. During routine IAV surveillance in exhibition swine in the summer of 2015, influenza-like illness (ILI) was noted in swine at 6 of 14 agricultural fairs surveilled in Michigan, USA. Acute outbreaks of ILI in swine at 2 fairs were so severe that animal health and fair officials closed the swine barns to non-essential personnel out of concern for potential human exposure to IAV. Nasal swab specimens were collected from representative swine and tested for IAV (online Technical Appendix, <https://wwwnc.cdc.gov/EID/article/23/7/17-0019-Techapp1.pdf>). IAV was not detected in samples from the pigs at any of the Michigan fairs; however, next-generation sequencing (NGS) identified porcine hemagglutinating encephalomyelitis virus (PHEV) in a specimen from a clinically ill pig.

Following the initial PHEV detection, all samples from the 14 Michigan fairs held in 2015 were screened for the coronavirus; PHEV was detected at 10 (71.4%) of the 14 fairs, with 108 (38.7%) of 279 pigs testing positive. Given the high prevalence of PHEV in Michigan exhibition swine and the uncommon clinical presentation for PHEV (i.e., ILI in market-age pigs), we initiated further epidemiologic investigation.

Author affiliations: The Ohio State University, Columbus, Ohio, USA (J.N. Lorbach, J.M. Nolting, A.S. Bowman); Ohio Department of Agriculture, Reynoldsburg, Ohio, USA (L. Wang, Y. Zhang); Michigan State University, East Lansing, Michigan, USA (M. Benjamin); National Veterinary Services Laboratories, Ames, Iowa, USA (M.L. Killian)

DOI: <https://doi.org/10.3201/eid2307.170019>

The Study

We screened nasal swabs from pigs at 14 Ohio fairs and 14 Indiana fairs for PHEV (detailed methods in online Technical Appendix). Pigs at 4 of the Indiana fairs and 5 of the Ohio fairs exhibited signs of respiratory disease. We detected PHEV in 4 (14.3%) of 28 Ohio and Indiana fairs; 23 (4.1%) of 560 pigs tested positive. The increased risk of PHEV detection in samples from Michigan exhibition swine compared with samples collected from pigs in Ohio and Indiana (risk ratio 9.4, 95% CI 6.2–14.4) indicated epizootic behavior of PHEV in the Michigan fairs.

Although PHEV has been recognized for decades, few PHEV genomes have been publicly deposited. We performed NGS on representative PHEV-positive samples to investigate genetic diversity; 10 complete sequences and 1 partial sequence were obtained. Sequence analysis showed that the 10 complete PHEV strains had 2.1%–2.2% genome difference from a PHEV strain from Belgium (VW572) and 7.2%–7.4% genome difference from human enteric coronavirus (CoV) (HECV) 4408, bovine CoV Kakegawa, and white-tail deer CoV WD470 (Figure 1). Complete genome, nonstructural 2 (NS2) gene, spike gene, and NS4.9 gene phylogenetic analyses indicated 3 distinct clusters, referred to as genotypes 1–3, based on deletions in the NS2 gene (Figure 2; online Technical Appendix). It is likely that the deletions observed in this study contribute to viral evolution and may confer respiratory tropism of PHEV because deletion patterns are common in the genome of porcine respiratory CoV, which has a strong respiratory tropism. In contrast, the 3 other porcine CoVs have a strong enteric tropism (transmissible gastroenteritis virus, porcine epidemic diarrhea virus, and porcine deltacoronavirus).

The presence of ILI in pigs at multiple Michigan fairs, along with the increased risk of PHEV detection at these fairs, supports a causal link between PHEV and respiratory disease. PHEV is a single-stranded positive-sense RNA coronavirus belonging to the family *Coronaviridae*, genus *Betacoronavirus*. The virus is 1 of 5 known porcine CoVs causing disease in swine and is considered endemic worldwide, where it maintains itself by successively infecting groups of animals after replacement or weaning (2,3). PHEV typically affects pigs <3 weeks of age; clinical syndromes include vomiting and wasting disease and

¹These authors contributed equally to this article.

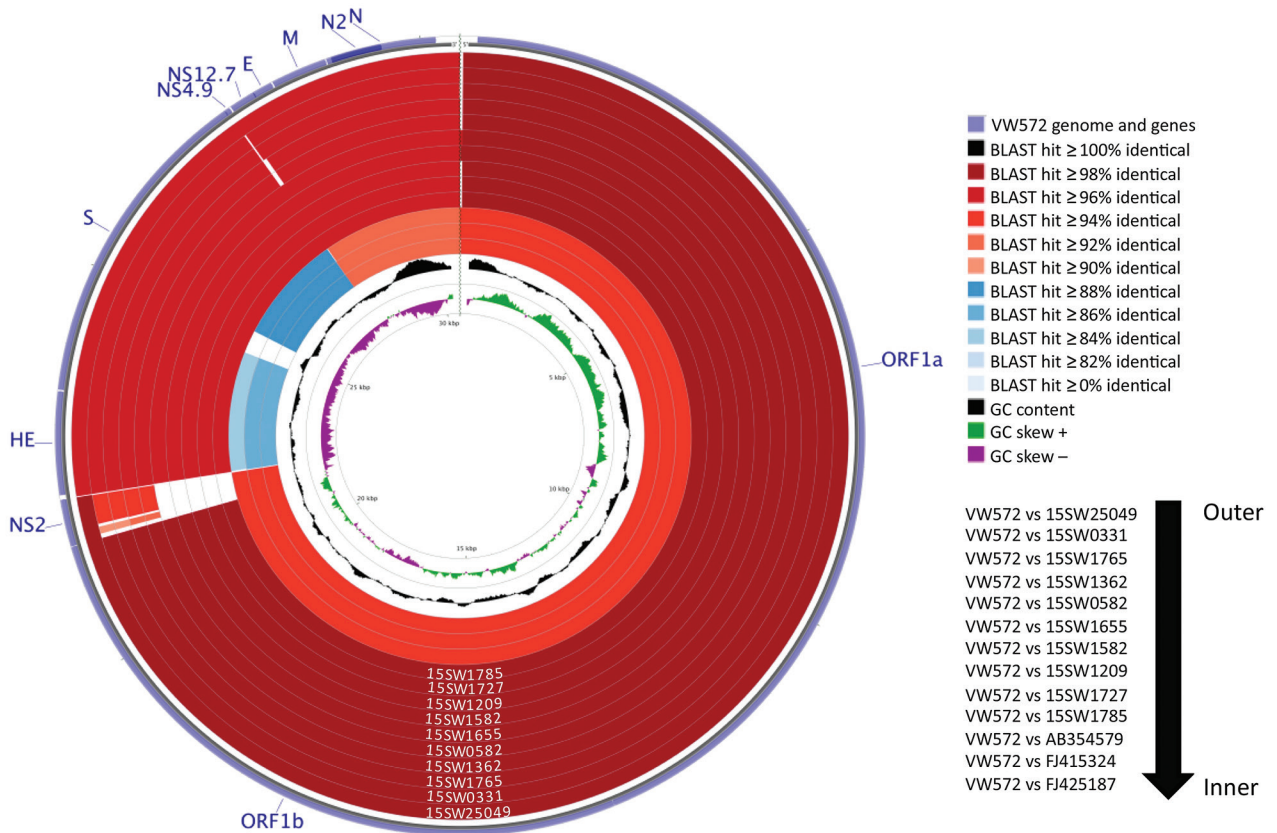

encephalomyelitis (4,5). Upper respiratory tract and pulmonary lesions have rarely been described (6); however, the primary route of PHEV infection is through upper respiratory tract epithelium. Sneezing and coughing may be the first clinical signs observed in piglets, supporting our premise that PHEV may cause respiratory disease in older swine (2). Although there are no data to definitively prove this premise, a previous report suggested an association between PHEV and clinical disease in older animals (7). A confounder at breeding facilities is the presence of animals of multiple age groups and bias toward recognizing the classical disease in piglets; our data represent a relatively homogenous group of market-age pigs.

Our findings also appear to highlight a distinct transmission network within Michigan exhibition swine; despite geographic contiguity and no barriers to interstate travel, Michigan samples, compared with those from Ohio and Indiana, yielded different proportions of PHEV detection.

This finding is further supported by the observation that PHEV sequenced from Michigan fairs was predominantly genotype 2, which was not detected in Ohio or Indiana (Table). Such a transmission network may be the result of common routes of travel or sites of commingling of swine, including larger swine exhibitions before county fairs. Animal networks have been described in additional species and locations and are not unique to the Michigan fairs (8,9).

During our interpretation of the data, we considered several limitations. First, no tissues were available to demonstrate pathologic lesions associated with the virus. However, NGS failed to detect the presence of additional pathogens aside from a single sample that contained porcine parainfluenza virus type 1 in addition to PHEV. Second, detection of PHEV in samples could not be directly correlated with respiratory disease in individual animals due to assessment of ILI at the fair level. However, at the fairs where barns were closed because of concerns of IAV,

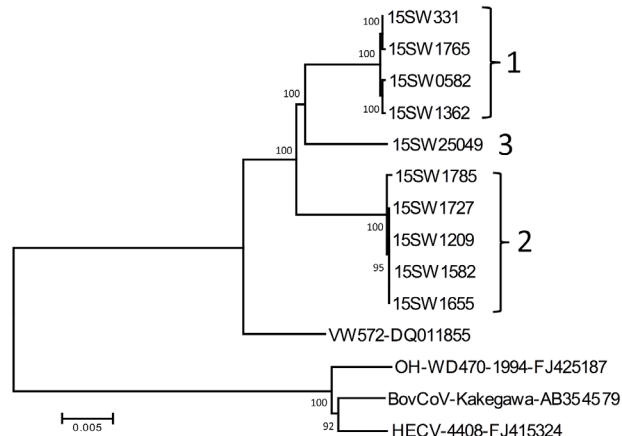

Figure 2. Phylogenetic tree constructed on the basis of the whole-genome sequence of porcine hemagglutinating encephalomyelitis virus (PHEV) strains from fairs in Michigan, Indiana, and Ohio, USA, 2015 (indicated by genotype labels at right), compared with bovine CoV (BovCoV), human enteric CoV (HECV), and white-tail deer CoV and a reference PHEV strain from Belgium (VW572). Reference sequences obtained from GenBank are indicated by strain name and accession number. Numbers along branches indicate bootstrap values. Scale bar indicates nucleotide substitutions per site. CoV, coronavirus.

most swine were affected by ILI, and >50% of pigs were PHEV positive at these locations. Last, it is difficult to conclude whether genotype 2 PHEV was present in Ohio and Indiana, because not all positive samples were sequenced.

Although the genotype data may not be statistically significant because of the small sample size, there appears to be a clear difference in genotype distributions.

Conclusions

Our findings provide strong evidence for the role of PHEV as a respiratory pathogen and genomic characterization of clinically relevant strains circulating in US swine herds. The ILI in swine in this study is considered an atypical presentation of PHEV and may reflect unique presentation of PHEV in older but naive swine populations, an atypical form of disease, or increased virulence. Guarded interpretation of our data suggests that, at minimum, PHEV should be considered as a differential diagnosis in clinical outbreaks of ILI in market-age swine. Future surveillance and research are needed to further investigate the association of PHEV with respiratory disease in commercial and exhibition swine.

The rapid government and local authority responses to the outbreaks of respiratory disease in pigs at the fairs involved in our study was justified given the public health threat of IAV. Variant IAV (H3N2v) was responsible for many human cases, including 1 death, during outbreaks in 2011–2016 in which swine-to-human transmission was demonstrated (10,11). Most recently, in August 2016 there was a regional outbreak of H3N2v virus infection in 18 persons with recent exposure to swine at 7 fairs in Michigan and Ohio (11). PHEV is not known to cause any disease in humans, but the PHEV transmission network uncovered in

Table. PHEV obtained from samples of swine at fairs in Michigan, Indiana, and Ohio, USA, 2015*

Fair	Total no. samples	No. PHEV positive	Risk for PHEV positivity	ILI	Strain name	Genotype	GenBank accession no.
Michigan							
A	20	9	0.45	Yes	PHEV-CoV USA-15SW1727	2	KY419111
B	20	20	1.00	Yes	PHEV-CoV USA-15SW1362	1	KY419110
C	20	10	0.50	Yes	PHEV-CoV USA-15SW1582	2	KY419113
D	20	20	1.00	Yes	PHEV-CoV USA-15SW1655	2	KY419109
E	19	7	0.37	Yes	PHEV-CoV USA-15SW25049	3	KY419103
F	20	19	0.95	Yes	PHEV-CoV USA-15SW1209	2	KY419107
G	20	9	0.45	No	NA	NA	NA
H	20	9	0.45	No	NA	NA	NA
I	20	4	0.20	No	PHEV-CoV USA-15SW1785	2	KY419106
J	20	1	0.05	No	PHEV-CoV USA-15SW24992†	2	KY419108
All others, n = 4	80	0	0.00	No	NA	NA	NA
Total, n = 14	279	108	0.39				
Indiana							
K	20	1	0.05	No	NA	NA	NA
L	20	8	0.40	No	PHEV-CoV USA-15SW1765	1	KY419112
M	20	1	0.05	No	PHEV-CoV USA-15SW0331	1	KY419104
All others, n = 11	220	0	0.00	Yes (4)	NA	NA	NA
Ohio							
N	20	13	0.65	No	PHEV-CoV USA-15SW0582	1	KY419105
All others, n = 13	260	0	0.00	Yes (5)	NA	NA	NA
Ohio/Indiana							
Total, n = 28	560	23	0.04				

*Reverse transcription PCR PHEV detection results are shown with calculated risk. Aggregate data for Michigan or Ohio and Indiana are shown. PHEV strain name and corresponding GenBank accession numbers are listed for samples that yielded sequence data. ILI, influenza-like illness; NA, not applicable; PHEV, porcine hemagglutinating encephalomyelitis virus.
†Partial genome (nonstructural protein 2).

Michigan during 2015 may represent a pathway for both intraspecies and interspecies transmission of additional pathogens, including IAV. Although it is inappropriate to make leaps in assuming that this report could predict such a future outbreak, it is worth contemplating potential outcomes had the animals been transmitting a zoonotic agent such as IAV.

Acknowledgments

Thanks to Sarah Lauterbach, Nola Bliss, Michele Zentkovich, Grant Price, Alison Martin, Christie Hammons, Amber Kihm, and Sarah Nelson for their efforts in sample collection and screening activities. We also extend our gratitude to the participating fairs, as well as Duane Trupiano, James Averill, Steve Hussey, Nancy Barr, Tom Guthrie, and Beth Ferry, for their assistance during the surveillance project.

This work was supported by the Centers of Excellence for Influenza Research and Surveillance, National Institute of Allergy and Infectious Diseases, National Institutes of Health, Department of Health and Human Services contract HHSN272201400006C.

Dr. Lorbach is a graduate research associate and resident in veterinary anatomic pathology at The Ohio State University College of Veterinary Medicine. His research interests include pathogenesis of influenza A virus, inflammatory signaling pathways, and molecular epidemiology. Dr. Wang is a researcher in the Animal Disease Diagnostic Laboratory, Ohio Department of Agriculture. His research interests include infectious diseases, molecular virology, and vaccine development.

References

- Grant JR, Arantes AS, Stothard P. Comparing thousands of circular genomes using the CGView Comparison Tool. *BMC Genomics*. 2012;13:202. <http://dx.doi.org/10.1186/1471-2164-13-202>
- Saif LJ, Pensaert MB, Sestak K, Yeo SG, Jung K. Coronaviruses. In: Zimmerman JJ, Karriker LA, Ramirez A, editors. *Diseases of swine*. 10th ed. Hoboken (NJ): Wiley-Blackwell; 2012. p. 517–20.
- Wang L, Byrum B, Zhang Y. Detection and genetic characterization of deltacoronavirus in pigs, Ohio, USA, 2014. *Emerg Infect Dis*. 2014;20:1227–1230. <http://dx.doi.org/10.3201/eid2007.140296>
- Quiroga MA, Cappuccio J, Piñeyro P, Basso W, Moré G, Kienast M, et al. Hemagglutinating encephalomyelitis coronavirus infection in pigs, Argentina. *Emerg Infect Dis*. 2008;14:484–6. <http://dx.doi.org/10.3201/eid1403.070825>
- Cartwright SF, Lucas M, Cavill JP, Gush AF, Blandford TB. Vomiting and wasting disease of piglets. *Vet Rec*. 1969;84:175–6. <http://dx.doi.org/10.1136/vr.84.7.175>
- Cutlip RC, Mengeling WL. Lesions induced by hemagglutinating encephalomyelitis virus strain 67N in pigs. *Am J Vet Res*. 1972;33:2003–9.
- Alsop JE. A presumptive case of vomiting and wasting disease in a swine nucleus herd. *Journal of Swine Health and Production*. 2006;14:97–100.
- Nelson MI, Stucker KM, Schobel SA, Trovao NS, Das SR, Dugan VG, et al. Introduction, evolution, and dissemination of influenza A viruses in exhibition swine, USA, 2009–2013. *J Virol*. 2016;90:10963–71. <http://dx.doi.org/10.1128/JVI.01457-16>
- Xu W, Berhane Y, Dubé C, Liang B, Pasick J, VanDomselaar G, et al. Epidemiological and evolutionary inference of the transmission network of the 2014 highly pathogenic avian influenza H5N2 outbreak in British Columbia, Canada. *Sci Rep*. 2016;6:30858. <http://dx.doi.org/10.1038/srep30858>
- Bowman AS, Nelson SW, Page SL, Nolting JM, Killian ML, Sreevatsan S, et al. Swine-to-human transmission of influenza A(H3N2) virus at agricultural fairs, Ohio, USA, 2012. *Emerg Infect Dis*. 2014;20:1472–80. <http://dx.doi.org/10.3201/eid2009.131082>
- Schicker RS, Rossow J, Eckel S, Fisher N, Bidol S, Tatham L, et al. Outbreak of influenza A(H3N2) variant virus infections among persons attending agricultural fairs housing infected swine—Michigan and Ohio, July–August 2016. *MMWR Morb Mortal Wkly Rep*. 2016;65:1157–60. <http://dx.doi.org/10.15585/mmwr.mm6542a1>

Address for correspondence: Andrew S. Bowman, Department of Veterinary Preventive Medicine, The Ohio State University, 1920 Coffey Rd, Columbus, OH 43210, USA; email: bowman.214@osu.edu; Yan Zhang, Animal Disease Diagnostic Laboratory, Ohio Department of Agriculture, 8995 East Main St, Reynoldsburg, OH 43068, USA; email: yzhang@agri.ohio.gov



Manage your email alerts so you only receive content of interest to you.

Sign up for an online subscription:
wwwnc.cdc.gov/eid/subscribe.htm

Porcine Hemagglutinating Encephalomyelitis Virus and Respiratory Disease in Exhibition Swine, Michigan, USA, 2015

Technical Appendix

Methods

Study Sites and Sampling

During the summer of 2015, an ongoing influenza A virus (IAV) surveillance program targeting exhibition swine was expanded to include 14 Michigan fairs. At the conclusion of swine exhibition activities and before departure of swine from enrolled fairs, study team members visually observed the swine for clinical signs of respiratory disease and collected nasal swab samples. Twenty specimens per fair were targeted to provide 95% confidence of IAV detection, assuming a prevalence $\geq 15\%$. Individual nasal swab specimens were placed in vials containing brain heart infusion media supplemented with penicillin G and streptomycin and frozen at -80°C until processing. A total of 279 nasal swab specimens were collected from the 14 Michigan fairs. The Ohio State University Institutional Animal Care and Use Committee approved the use of animals in this study under protocol no. 2009A0134.

Pathogen Detection and Epidemiology

We extracted RNA from the samples using Mag-Bind Viral DNA/RNA 96 Kit (Omega, Norcross, GA, USA) and MagMAX Express-96 Deep Well Magnetic Particle Processor (ThermoFisher, Waltham, MA, USA). We initially screened the samples for IAV by real-time reverse transcription PCR (rRT-PCR) with a commercially available kit (VetMAX-Gold SIV Detection Kit; Applied Biosystems, Austin, TX, USA) using manufacturer-provided protocols. We screened samples for porcine reproductive and respiratory syndrome virus (PRRSV) by rRT-PCR using described methods (1).

We selected a sample taken from a Michigan exhibition pig with clinical respiratory disease typical for this outbreak and negative for IAV and PRRSV for de novo sequencing to identify potential pathogens within the specimen. We prepared an RNA library using Ion Total RNA-Seq Kit version 2 (ThermoFisher) according to manufacturer instructions. We amplified the library with the Ion PGM Hi-Q Chef Kit on the Ion Chef System and sequenced on the Ion Personal Genome Machine System. Following the detection of porcine hemagglutinating encephalomyelitis virus (PHEV), we screened all remaining samples from pigs at Michigan fairs for PHEV by rRT-PCR using specific primers and protocol provided by the University of Minnesota Veterinary Diagnostic Laboratory (protocol MOL.SOP.291).

IAV surveillance activities during 2015 involved agricultural fairs beyond Michigan, including those taking place in Ohio and Indiana. We selected samples from 14 fairs from each of those states ($n = 280$ per state) for PHEV screening to compare them to the prevalence in Michigan exhibition swine. Fairs from Ohio and Indiana were selected based on influenza-like illness (ILI) in the pigs, corresponding time to Michigan fairs, and IAV-negative swine samples. Using the pooled results in Ohio and Indiana (OH/IN), we compared the risk of PHEV detection both between Michigan and OH/IN individual samples and between Michigan and OH/IN fairs. We calculated risk ratio (RR) for individual samples and individual fairs, and constructed 95% CIs. We calculated p values using Fischer's exact probability test (2).

Genomic Characterization and Comparison

We selected 1 sample per fair where PHEV was detected for sequencing on the basis of the lowest PHEV rRT-PCR cycle threshold value at each fair ($n = 14$). We applied a sequence-independent, single-primer amplification method to amplify the genome of PHEV from extracted RNA. We used the Nextera XT DNA Library Preparation Kit (Illumina, San Diego, CA, USA) to prepare a next-generation sequencing library followed by sequencing on MiSeq. We used both Ray and SPAdes softwares for de novo assemble of 9 PHEV strains. We closed small sequencing gaps by using a Sanger sequencing method, and reamplified 2 strains (15SW0331 and 15SW0582) with a relatively smaller percentage of genome coverage (54% and 80%, respectively) by using 21 pairs of PHEV-specific primers followed by sequencing on MiSeq. We aligned and compared sequences using MUSCLE (MEGA Software version 6.06; www.megasoftware.net). We confirmed all insertions and deletions by Sanger sequencing. We performed phylogenetic comparison of the sequenced PHEV strains to reference coronavirus

sequences obtained from GenBank by complete sequence, nonstructural 2 (NS2) gene, spike gene, and NS4.9 gene. We constructed dendrograms using the neighbor-joining method with the MEGA software package. We performed bootstrap resampling (1,000 replications), and bootstrap values are indicated for each node.

Results

Pathogen Detection

Our initial screening results determined that all samples were negative for IAV. All Michigan samples were negative for PRRSV, but 1 sample from each comparison state (Ohio and Indiana) tested positive for PRRSV. De novo sequencing identified PHEV in a sample from a clinically ill Michigan exhibition pig. The resulting sequence covered 100% of the genome with an average depth of coverage of 65×, including numerous regions with <10× coverage; sequence gaps were closed with specific primers.

Genomic Sequencing

We deposited sequence data for complete and partial genomes in GenBank; previously, only 1 complete genome (PHEV-VW572) had been available in the database (Technical Appendix Figure 1). Sequence mapping analysis of raw reads showed that over 50% genome coverage for PHEV was obtained for 10 (15SW0331, 15SW0582, 15SW1209, 15SW1362, 15SW1582, 15SW1655, 15SW1727, 15SW1765, 15SW1785, and 15SW25049) out of 14 samples. Among the PHEV strains identified in the current study, the genomes range from identical to 1.8% difference, demonstrating presence of distinct strains. Further analysis reveals that the PHEV strains identified in the present study contain deletions and/or insertions in different genes, including open reading frame 1b (ORF1b), NS2, spike, NS4.9, and 3' untranslated region (UTR) (Technical Appendix Figures 2–4).

Compared with VW572, 4 (15SW0331, 15SW0582, 15SW1362, and 15SW1765) of the 10 PHEV samples contain a 3-nt deletion (GTA) in the ORF1b at positions 20089–20091, resulting in a 1-amino-acid deletion (NEP vs. NGKP). In comparison with VW572, HECV 4408, Kakegawa, and WD470, all 10 PHEV strains have different deletion patterns in the NS2 gene, resulting in 5 different lengths of the NS2 gene. Five strains (15SW1209, 15SW1582, 15SW1655, 15SW1727, and 15SW1785) have a truncated NS2 gene, with the smallest genome

size of NS2, 61 nt, encoding only a 12-aa truncated NS2 protein (Technical Appendix Figure 5). The NS2 genes of 4 strains (15SW0331, 15SW1765, 15SW0582, and 15SW1362) are 745 nt, 745 nt, 749 nt, and 751 nt in length, respectively, longer than that of VW572, but encode only 5 aa because of a premature stop codon caused by a 44-nt deletion in the 5' NS2. 15SW25049 has the largest size of NS2 gene, 826 nt, encoding a 195-aa protein, which is 1 aa longer than that of VW572 NS2 protein.

In the case of the spike gene, compared with VW572, 9 PHEV strains have a 3-nt deletion (AAT) at positions 2680–2682, resulting in a single amino acid deletion (N, Asn), whereas 15SW25049 does not have this deletion (just as in 2 Canadian PHEV strains [67N and IAF-404]). In the case of the NS4.9 gene, 3 different deletion patterns were identified in the 10 PHEV-positive samples, as compared to VW572. The deletions result in 3 different lengths of NS4.9 (15SW0582 and 15SW1362: 13aa; 15SW0331 and 15SW1765: 28aa; 15SW1209, 15SW1582, 15SW1655, 15SW1727, 15SW1785 and 15SW25049: 20aa) (Technical Appendix Figures 6 and 7). The truncated NS4.9 protein pattern of 15SW1209, 15SW1582, 15SW1655, 15SW1727, 15SW1785 and 15SW25049 has been previously reported in 2 Canadian PHEV strains (67N and IAF-404) (3). In the 3' UTR, compared with VW570, all 10 PHEV strains we detected have 1 unique single nucleotide deletion at position 174, and 5 strains (15SW0331, 15SW0582, 15SW1362, 15SW1765 and 15SW25049) have an additional single nucleotide deletion at position 190. We identified the NS2 gene of PHEV in 1 sample (15SW24992) and detected porcine parainfluenza virus-1 (PPIV-1) in 1 sample (15SW0582) in addition to PHEV.

Four strains (15SW0331, 15SW0582, 15SW1362, and 15SW1765) form genotype 1, 5 strains (15SW1209, 15SW1582, 15SW1655, 15SW1727, and 15SW1785) form genotype 2, and 1 strain (15SW25049) alone or together with VW572 or IAF-404 form genotype 3. The strain 15SW25049 (genotype 3) is more closely related to genotype 1 in the phylogenetic trees of the complete genome and NS2 gene, whereas it is more closely related to genotype 2 in the spike gene and NS4.9 gene trees. All 10 strains are distantly related to VW572, except in the NS2 gene tree, where VW572 is closely related to 15SW25049.

Overall, genomic and phylogenetic characterization demonstrated that the 10 PHEV strains are novel PHEV variants. Although deletions in the NS2 and NS4.9 genes was previously

reported in VW572, all 10 US PHEV strains reported here possess novel deletion patterns in both these genes; we also observed new deletions in ORF1b, spike gene, and 3' UTR.

References

1. Opriessnig T, McKeown NE, Harmon KL, Meng XJ, Halbur PG. Porcine circovirus type 2 infection decreases the efficacy of a modified live porcine reproductive and respiratory syndrome virus vaccine. *Clin Vaccine Immunol.* 2006;13:923–9. <http://dx.doi.org/10.1128/CVI.00074-06>
2. Lowry R. VassarStats: Website for Statistical Computation [online software]. 2016 Mar 28 [cited 2016 Oct 10]. <http://vassarstats.net/>
3. Sasseville AM, Boutin M, Gélinas A-M, Dea S. Sequence of the 3'-terminal end (8.1 kb) of the genome of porcine haemagglutinating encephalomyelitis virus: comparison with other haemagglutinating coronaviruses. *J Gen Virol.* 2002;83:2411–6. <http://dx.doi.org/10.1099/0022-1317-83-10-2411>
4. Carver T, Thomson N, Bleasby A, Berriman M, Parkhill J. DNAPlotter: circular and linear interactive genome visualization. *Bioinformatics.* 2009;25:119–20. <http://dx.doi.org/10.1093/bioinformatics/btn578>

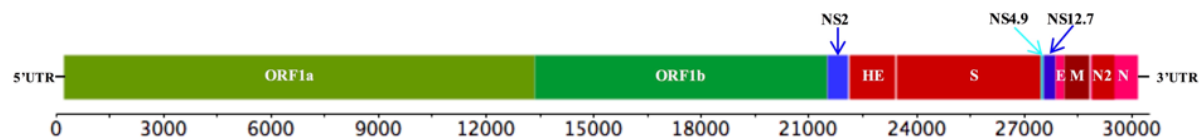

Technical Appendix Figure 1. Schematic representation of the porcine hemagglutinating encephalomyelitis virus (PHEV) genome (PHEV-VW572 strain, GenBank accession no. DQ011855) using DNAPlotter software (4). The first two thirds of the PHEV genome are open reading frames (ORF) 1a and 1b encoding the replicase. The remaining genome encodes 6 structural proteins (hemagglutinin-esterase protein, HE; spike glycoprotein, S; envelope protein, E; membrane protein, M; nucleocapsid proteins, N and N2) and three nonstructural proteins (NS2, NS4.9, and NS12.7).

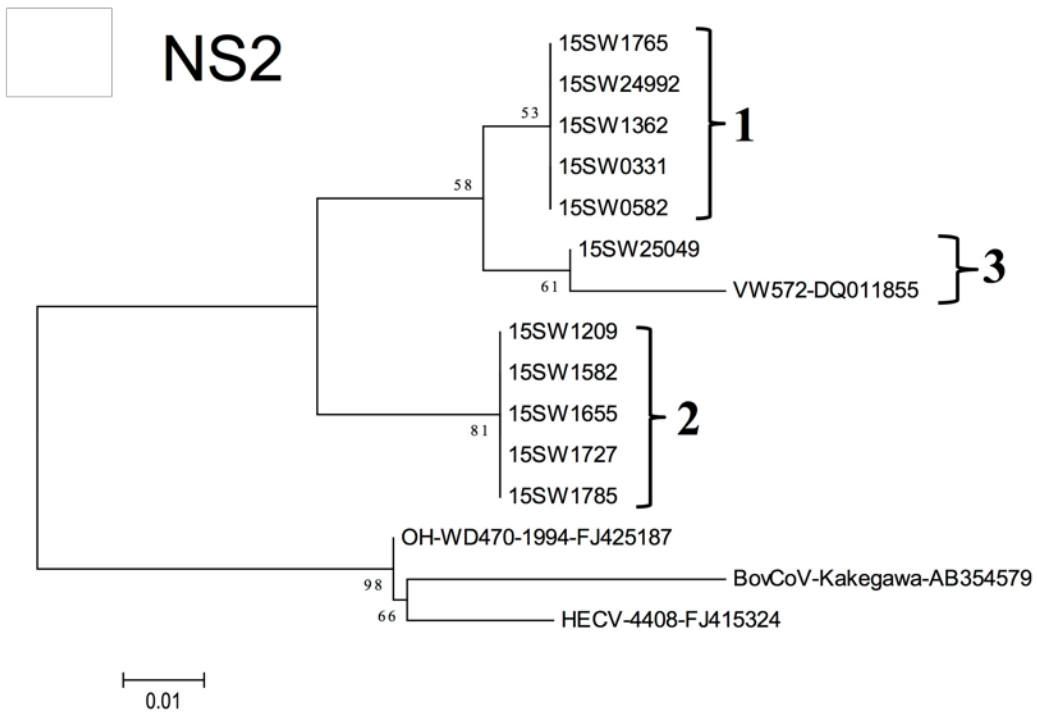

Technical Appendix Figure 2. Phylogenetic tree constructed on the basis of the NS2 gene of porcine hemagglutinating encephalomyelitis virus (PHEV) strains, bovine CoV, human enteric CoV, and white-tail deer CoV. Reference sequences obtained from GenBank are indicated by strain name and accession number. Scale bar represents nucleotide substitutions per site.

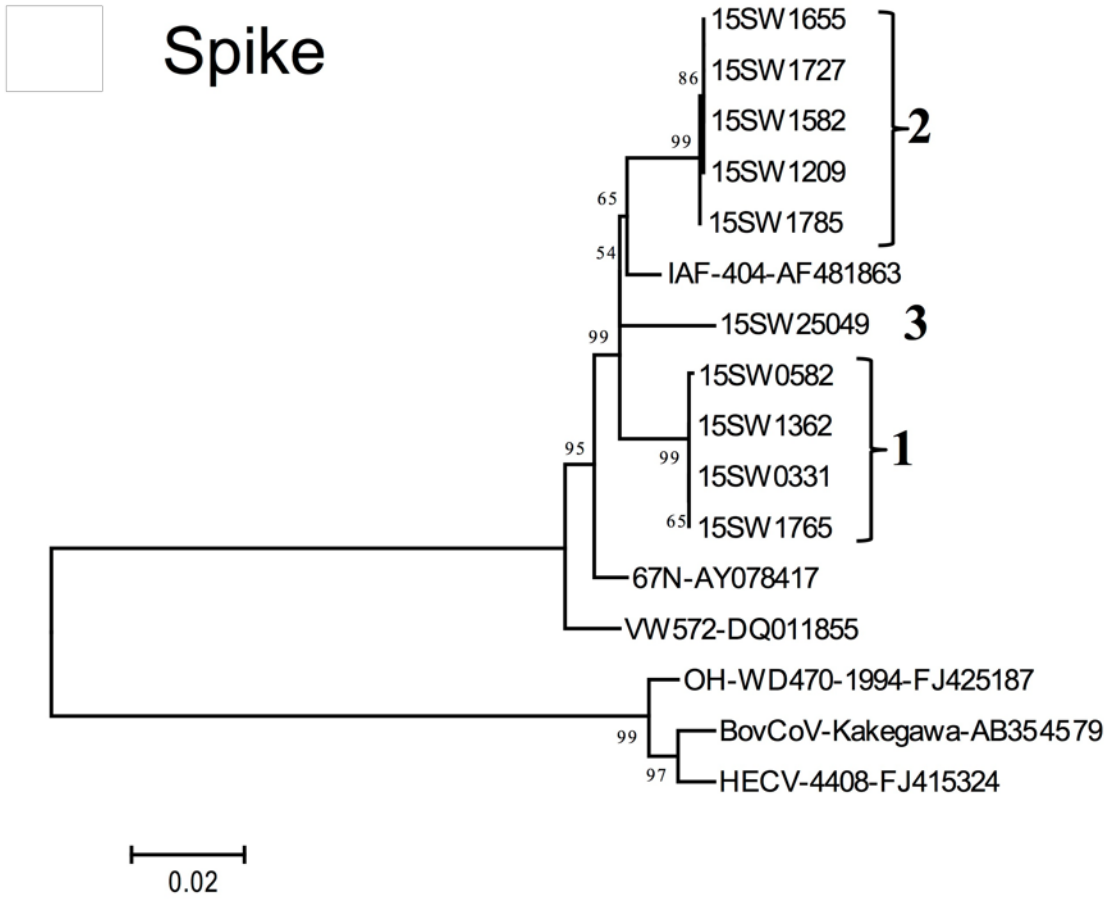

Technical Appendix Figure 3. Phylogenetic tree constructed on the basis of the spike gene of porcine hemagglutinating encephalomyelitis virus (PHEV) strains, bovine CoV, human enteric CoV, and white-tail deer CoV. Reference sequences obtained from GenBank are indicated by strain name and accession number. Scale bar represents nucleotide substitutions per site.



NS4.9

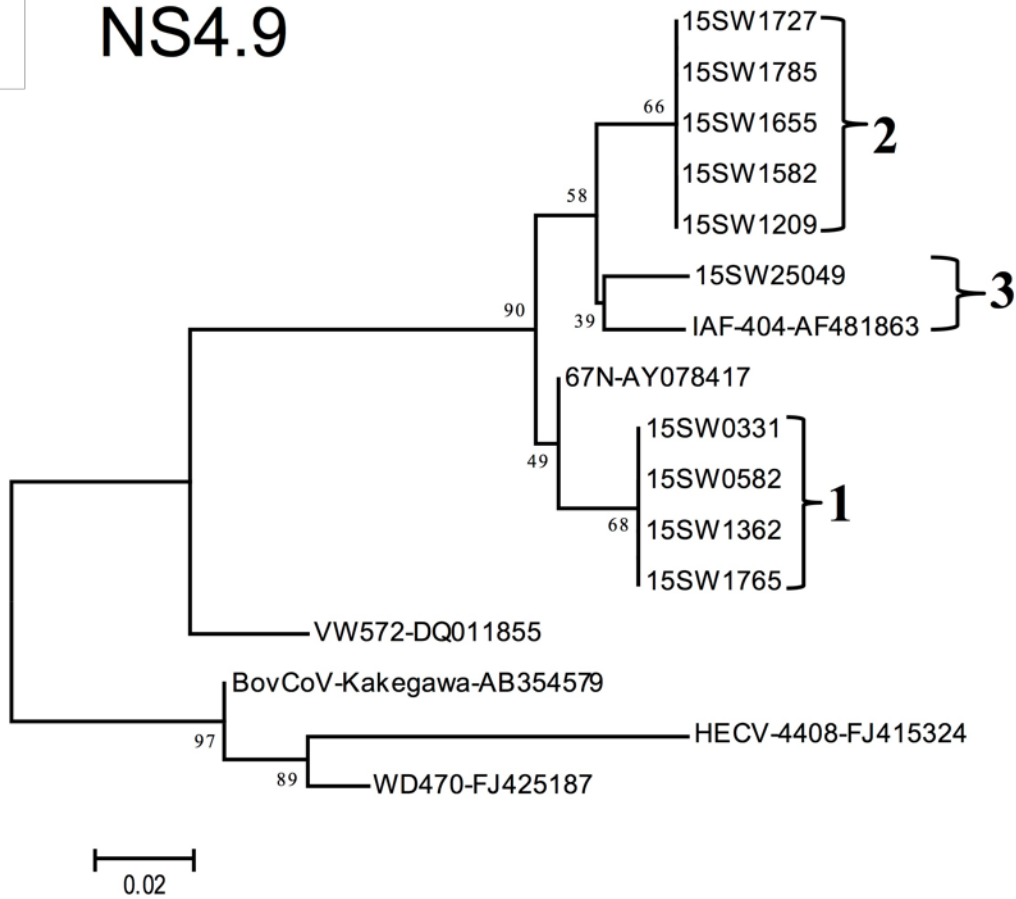

Technical Appendix Figure 4. Phylogenetic tree constructed on the basis of the NS4.9 gene of porcine hemagglutinating encephalomyelitis virus (PHEV) strains, bovine CoV, human enteric CoV, and white-tail deer CoV. Reference sequences obtained from GenBank are indicated by strain name and accession number. Scale bar represents nucleotide substitutions per site.

NS2 sequence

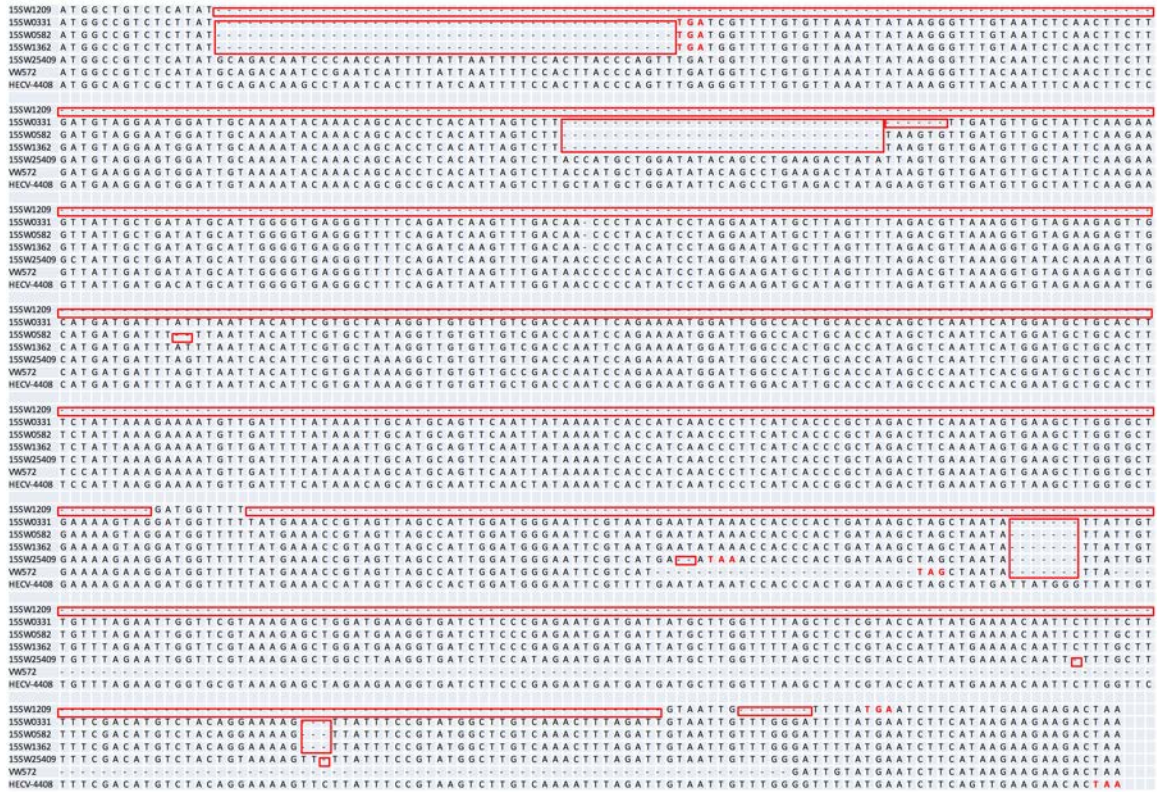

Technical Appendix Figure 5. Nucleotide sequence alignment of NS2 gene of porcine hemagglutinating encephalomyelitis virus (PHEV) strains (15SW1209, 15SW0331, 15SW0582, 15SW1362, 15SW25409, and VW572), and HECV-4408. Deletion regions have been marked with red frames. Stop codons for each strain are in red. MUSCLE alignment program was performed with MEGA.

NS4.9 nucleotide sequence

15SW0582	A T G A C G A T T A A T T T C G T C T T T A G - - - - -
15SW0331	A T G A C G A T T A A T T T C G T C T T T A - - - - -
15SW1209	A T G A C G A T T A A T T T C G T C T T T G G T T T - - - - - C C A T A T A - - - - -
VW572	A T G A C G A C T A A G T T C G T C T T T G A T T T A C T G A C T C T T G A C G A T A T A - - - - -
WD470	A T G A C G A C T A A G T T C G T C T T T G A T T T A T T G G C T C C T G A C G A T A T A T T A C A T C C C T T C C A A T C A T G T G A A T
HECV-4408	A T G A C G A C T A A G T T C G T C T T T G C T T T A G T G G C T C C T G A C G A T A C A T T A C A T C C C T T C A A T C A T G T T A A G
BovCoV	A T G A C G A C T A A G T T C G T C T T T G A T T T A T T G G C T C C T G A C G A T A T A T T A C A T C C C T T C A A T C A T G T G A A G
15SW0582	- - - - -
15SW0331	- - - - -
15SW1209	- - - - -
VW572	- - - - -
WD470	C T A A T T A T A A G A C C C A T T T A G G T C T A G C A T A T T A T A A T A G C T A C C A C A A T G C C T G C T G T T T A G T G G G T A
HECV-4408	C T A A T T A T A A G A C C C A T T G A G G T C G A G C A T A T T A T A A C A G C T A C C A C A A T G C C T G C T T T T T A G T G G G T A
BovCoV	C T A A T T A T A A G A C C C A T T G A G G T C G A G C A T A T T A T A A T A G C T A C C A C A A T G C C T G C T G T T T A G T G G G T A
15SW0582	- - - - -
15SW0331	- - - - -
15SW1209	- - - - -
VW572	- - - - -
WD470	C T G T G T C T T A T A T A A C T A G T A A A C C T G C A A T G C C A A T G G C T A C A A C C A T T G A A G G T G C A G A T T A T A C T A
HECV-4408	C T G T G T C T T A T A T A A C T A G T A A A C C T G T A A T G C C A A T G G C T A C A A C C A T T G A T G G T A C A G A T T A T A C T A
BovCoV	C T G T G T C T T A T A T A A C T A G T A A A C C T G T A A T G C C A A T G G C T A C A A C C A T T G A C G G T A C A G A T T A T A C T A
15SW0582	- - - - -
15SW0331	- - - - -
15SW1209	- - - - -
VW572	- - - - -
WD470	A C A T T A T G C C T A T T A C T G T T C T T A C A A C A G T T T A T T T A G G C G T T T C T A T A G G T A T T G A C A C T A G C A C C A
HECV-4408	A C A T T A T G C C T A G T A C T G T T T T T A C A A C A G T T T A T T T A G G C G G T T T T A T A G G T A T T G A T A C T A G C A C C A
BovCoV	A T A T T A T G C C T A G T A C T G T T T C T A C A A C A G T T T A T T T A G G C T G T T C T A T A G G T A T T G A C A C T A G C A C C A
15SW0582	- - - - -
15SW0331	- - - - -
15SW1209	- - - - -
VW572	- - - - -
WD470	C T G G T T T T A C C T G T T T T T C A C G G T A C T A G T T C C A A A C C A T A T T A T A A T T C A G G T A G A C C T T A T A A C T T T
HECV-4408	C T G G T T T T A C C T G T T T T T C A C G G T A C T A G T T C C A A A C C A T A T T A T A A T T C A G G T A G A C C T T A T A A C T T T
BovCoV	C T G G T T T T A C C T G T T T T T C A C G G T A C T A G T T C C A A A C C A T A T T A T A A T T T A G G T A G A C C T T A T A A C T T T
15SW0582	- - - - -
15SW0331	- - - - -
15SW1209	- - - - -
VW572	- - - - -
WD470	A A G C A T T - - - - - T A C C A A A G T T T T T A A G G C T A C G C T C T A C T A A T G G A C A T C T G G T G C C C T G A
HECV-4408	A A G C A T T - - - - - T G C C A A A G T T T T T A A G G T A C G C T C T A C T A A T G G A C A T C T G G T G C C C T G A
BovCoV	A A G C A T T - - - - - T G C C A A A G T T T T T A A G G T A C G C T C T A T T A A T G G A C A T C T G G T G T C C T G A
15SW0582	- - - - -
15SW0331	- - - - -
15SW1209	- - - - -
VW572	A A G C A T T - - - - - T G C C A A A G T T T T T A A G G C A C T C C C T A T T A A T G G A C A T C T G G T G C C C T G A
WD470	A A G C A T T - - - - - A T T G C C A A A G T T T T T A A G G C C A C G C C C T A G T A A T G G A C A T C T G G A A A C C T G A
HECV-4408	A A G C A T T - - - - - A A T T G C T A A G T T T C T A A G A C C A C G C C C T A G T A A T G G A T A T T T G G A G A C C T G A
BovCoV	A A G C A T T A T T A A T T G C C A A A G T T C C T A A G G T C A C G C C C T A G T A A T G G A C A T C T G G A G A C C T G A

Technical Appendix Figure 6. Nucleotide sequence alignment of NS4.9 gene of porcine hemagglutinating encephalomyelitis virus (PHEV) strains (15SW0582, 15SW0331, 15SW1209, VW572), WD-470, HECV-4408, and BovCoV. Stop codons for each strain are in red. MUSCLE alignment program was performed with MEGA.

NS4.9 amino acid sequence

		Length
15SW0582	M T I N F V F S K A T L Y - - - - -	13
15SW0331	M T I N F V F S N F K H L P K F L R L R S T N G H L V P - - - - -	28
15SW1209	M T I N F V F G - - - F H I V I L S I C Q S F - - - - -	20
VW572	M T T K F V F D L L T L D D I V T L S I C Q S F - - - - -	24
WD470	M T T K F V F D L L A P D D I L H P S N H V N L I I R P I - - - - -	29
HECV-4408	M T T K F V F A L V A P D D T L H P F N H V K L I I R P I E V E H I I A T T M P A F	43
BovCoV	M T T K F V F D L L A P D D I L H P F N H V K L I I R P I E V E H I I I A T T M P A V	43

Technical Appendix Figure 7. Amino acid sequence alignment of NS4.9 gene of porcine hemagglutinating encephalomyelitis virus (PHEV) strains (15SW0582, 15SW0331, 15SW1209, VW572), WD-470, HECV-4408, and BovCoV. MUSCLE alignment program was performed with MEGA.