

**United Nations Mission to Investigate Allegations of the Use of Chemical Weapons  
in the Syrian Arab Republic**

**Report on the Alleged Use of Chemical Weapons in the Ghouta Area of Damascus  
on 21 August 2013**

**Note by the Secretary-General**

1. In transmitting simultaneously to the Security Council and the General Assembly the report on the incident which took place on 21 August 2013 in the Ghouta area of Damascus (see annex), the Secretary-General expresses his profound shock and regret at the conclusion that chemical weapons were used on a relatively large scale, resulting in numerous casualties, particularly among civilians and including many children. The Secretary-General condemns in the strongest possible terms the use of chemical weapons and believes that this act is a war crime and grave violation of the 1925 Protocol for the Prohibition of the Use in War of Asphyxiating, Poisonous or Other Gases, and of Bacteriological Methods of Warfare and other relevant rules of customary international law. The international community has a moral responsibility to hold accountable those responsible and for ensuring that chemical weapons can never re-emerge as an instrument of warfare.

2. The Secretary-General wishes to express his deep appreciation to the Head and members of the Mission, including the dedicated teams of experts from the Organisation for the Prohibition of Chemical Weapons and the World Health Organization. The Secretary-General is grateful for the support provided by Member States. The Secretary-General counts on the continued support of all concerned until the Mission completes its investigation into all other allegations and submits its final report.

3. The accession of the Syrian Arab Republic on 14 September 2013 to the Convention on the Prohibition of the Development, Production, Stockpiling and Use of Chemical Weapons and on their Destruction is a welcome development. As depositary of the Convention, the Secretary-General has long called for its universality. The Secretary-General welcomes the agreement reached on 14 September 2013 between the Russian Federation and the United States of America on a framework for the elimination of chemical weapons in the Syrian Arab Republic. He hopes that the Executive Council of the Organisation for the Prohibition of Chemical Weapons and the United Nations Security Council quickly move to consider and implement this proposal, which is aimed at expediting the fulfillment of the obligations of the Syrian Arab Republic under the Convention. The Secretary-General calls upon the Syrian Arab Republic to implement faithfully all of its disarmament obligations and he stands ready to facilitate international efforts aimed at providing assistance in this regard.

4. The Secretary-General reiterates that any use of chemical weapons by anyone under any circumstances is a grave violation of international law.

5. Where there are allegations of the use of chemical weapons, however, the international community looks to the United Nations for an impartial and objective determination whether, and to what extent, such allegations can be substantiated. It is imperative therefore that the authority extended to the Secretary-General by the General Assembly (A/RES/42/37 C) and endorsed by the Security Council (S/RES/620 (1988)) continues to be respected and that the mechanism related thereto continues to be strengthened. The Secretary-General believes that an effective mechanism to investigate allegations of the use of chemical weapons can serve as an important deterrent against their employment.

The Hague, 13 September 2013

Sir,

We have the honour to submit our report on the investigation of the alleged use of chemical weapons on 21 August 2013 in the Ghouta area of Damascus in the Syrian Arab Republic. We also confirm that, in accordance with our terms of reference, we are continuing our investigation of allegations of other incidents involving the use of chemical weapons in the Syrian Arab Republic and will report thereon as soon as possible. At your request, and taking into account the large scale of the 21 August events in the Ghouta area of Damascus and the continued loss of civilian life, we are issuing the Ghouta report without prejudice to our continuing investigation of, and final report on, other allegations involving the use of chemical weapons in the Syrian Arab Republic.

Having arrived in the Syrian Arab Republic on 18 August 2013, we were in Damascus on the 21 August preparing to conduct on-site inspections in connection with our investigation into the allegations concerning the use of chemical weapons in Khan al-Asal and in Sheik Maqsood and Saraqueb. Based on several reports of allegations on the use of chemical weapons in the Ghouta area of Damascus on 21 August 2013, you instructed us to focus our investigation efforts on the Ghouta allegations. We, therefore, proceeded to conduct on-site inspections in Moadamiyah in West Ghouta and Ein Tarma and Zamalka in East Ghouta.

On the basis of the evidence obtained during our investigation of the Ghouta incident, the conclusion is that chemical weapons have been used in the ongoing conflict between the parties in the Syrian Arab Republic, also against civilians, including children, on a relatively large scale. In particular, the environmental, chemical and medical samples, we have collected, provide clear and convincing evidence that surface-to-surface rockets containing the nerve agent sarin were used in Ein Tarma, Moadamiyah and Zamalka in the Ghouta area of Damascus. This result leaves us with the deepest concern.

We are grateful for the indispensable support provided by Ms. Angela Kane, the High Representative for Disarmament, and the innumerable UN Secretariat officials who have assisted us in Nicosia, Beirut, Damascus, The Hague and New York.

Our work is only possible due to the indispensable contributions of the OPCW and the WHO. We also deeply appreciate the efficient and effective assistance provided by the OPCW-designated laboratories in Finland, Germany, Sweden and Switzerland.

We also wish to thank you, Sir, for the confidence you have placed in us.

We count on your and the others continued support as we continue and hopefully soon complete our investigation into the other allegations.

Respectfully yours,

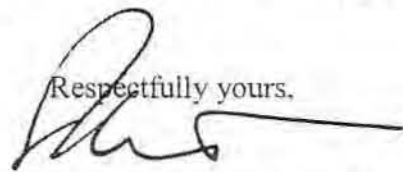

Professor Åke Sellström (Head of Mission)



Mr Scott Cairns  
(Head of and signing for the OPCW Component)



Dr Maurizio Barbeschi  
(Head of and signing for the WHO Component)

# UN Mission to Investigate Allegations of the Use of Chemical Weapons in the Syrian Arab Republic

## Report on Allegations of the Use of Chemical Weapons in the Ghouta Area of Damascus on 21 August 2013

### I. Terms of Reference

1. The Secretary-General decided to establish the UN Mission to Investigate Allegations of the Use of Chemical Weapons in the Syrian Arab Republic based on his authority under General Assembly resolution 42/37C and Security Council 620 (1988). The purpose of this Mission is to ascertain the facts related to the allegations of use of chemical weapons and to gather relevant data and undertake the necessary analyses for this purpose and to deliver a report to the Secretary-General.
2. For the purpose of ascertaining the facts related to the allegations of use of chemical weapons, gathering relevant data and undertaking the necessary analyses, the Secretary-General has requested the Organisation for the Prohibition of Chemical Weapons (“OPCW”) to put its resources at his disposal, including providing a team of experts to conduct fact-finding activities. The Secretary-General has also requested the World Health Organization (“WHO”) to provide technical support in assessing the public health, clinical and event-specific health aspects of the allegations that have been brought to his attention.
3. The UN Mission has conducted its investigation and all related activities in accordance with the terms of reference issued by the Secretary-General to the UN Mission including the above provisions as well as others on cooperation, methods of work and scope and reporting. As such, the terms of reference applied in respect of its investigation of the Gouta allegations on which this report is submitted without prejudice to the continuing investigation of, and final report on, all allegations involving the use of chemical weapons in the Syrian Arab Republic.
4. In discharging its mandate, the Mission was guided by the United Nations Guidelines and Procedures for the timely and efficient investigation of reports of the possible use of chemical and bacteriological (biological) or toxin weapons (A/44/561) and, as appropriate and to the extent applicable, the OPCW provisions as identified in Article I(5)(a) of the Supplementary Arrangement to the Agreement concerning the Relationship between the United Nations and the Organization for the Prohibition of Chemical Weapons.
5. Other relevant legal instruments governing the cooperation between the UN and the OPCW and WHO and guiding the work of the UN Mission are set out in Appendix I.

## II. Methodological Considerations

6. In its investigation of the alleged use of chemical weapons in the Ghouta area of Damascus on 21 August 2013, the Mission visited Moadamiyah on 26 August 2013 and Ein Tarma and Zamalka on 28-29 August. During its on-site visits, the UN Mission carried out the following activities:

- Interviews with survivors and other witnesses;
- Documentation of munitions and their sub-components;
- Collection of environmental samples for subsequent analysis;
- Assessment of symptoms of survivors;
- Collection of hair, urine and blood samples for subsequent analysis;

7. Doing so, the Mission adhered to the most stringent protocols available for such an investigation. Key to investigation methods of alleged use of chemical weapons are concepts like traceability, documentation, use of standardized and recognized procedures as well as relevant and up-to-date training of inspectors.

8. Traceability means that all processes and procedures are recorded and continuity is maintained for transparency and to withstand future scrutiny.

9. For example, the chain of custody procedures for sampling involved the following: The retrieval of samples is recorded and witnessed, samples are sealed, detailed documentation is prepared, transported to the preparatory laboratory under supervision of the members of the Mission, seals are confirmed and then broken, and the samples are representatively subdivided. The re-sealed samples are then distributed to the OPCW-designated laboratories with guidance documents, again, under the same supervision. The laboratories conduct their activities using standardized procedures (including quality assurance/quality control checks) for receiving, storing, and analyzing samples. The results are then returned under supervision to the investigation Mission for review. Each transfer of material is accompanied by handover receipts.

10. All information received, be it witness statements, pictures, videos, audios or patient records and other documentation, is recorded and registered for filing and archiving with the United Nations.

11. Methods for interviews, sampling, and documentation follow well established standard operating procedures (SOPs), developed and enforced by the OPCW and the WHO and in accordance with the Guidelines.

12. Mission members are regularly trained and periodically updated on aspects of their respective specializations, including risk assessments, epidemiology, sampling, scene assessment, acquisition and processing of bio-medical samples, the performance of interviews, munition designs, unexploded ordnances, epidemiology as well as safety and security.

13. The selection process used was designed to primarily identify survivors who had severe clinical presentations, since these were also expected to have had significant exposure to the chemical agent. The ability to provide a sound history of the event and identify the alleged impact sites was also considered in selecting survivors.

14. The selection process was guided by a standardized checklist that aimed to identify individuals who either demonstrated moderate to severe symptoms and signs, or were able to provide a clear and detailed history of the event. These survivors were requested to present to the local hospital on the day of the field visit to meet with the investigation Mission. Physicians at Zamalka were also asked to provide a purposive sample of eight medical records of patients with significant symptoms and signs.

### III. Narrative and Results of the Mission

15. Having arrived in the Syrian Arab Republic on 18 August 2013, we were in Damascus on the 21 August preparing to conduct on-site inspections in connection with our investigation into the allegations concerning the use of chemical weapons in Khan al-Asal and in Sheik Maqsood and Saraqueb. Based on several reports of allegations on the use of chemical weapons in the Ghouta area of Damascus on 21 August 2013, you instructed us to focus our investigation efforts on the Ghouta allegations. We, therefore, proceeded to conduct on-site inspections in Moadamiyah in West Ghouta and Ein Tarma and Zamalka in East Ghouta.

16. Pursuant to the joint understanding reached with the Syrian Government and separate arrangements agreed on an ad-hoc basis with the other parties to the conflict, a temporary ceasefire was effectively in place for five hours daily between 26-29 August.

17. The planning of this mission was therefore complex and highly delicate. The time window for operations was determined by actual hours of access. The route of entry into the areas remained uncertain until the final moments. Finally, the understanding of what the Mission could be expected to find once in opposition-controlled area was also uncertain. Crucial elements for the planning, such as the number of patients affected or the surface area covered by the attacks remained undefined until the actual arrival of the Mission on the affected sites. (For more information on preparation of the mission see Appendix 3).

18. On 26 August, the Mission visited Moadamiyah of West Ghouta for two hours. On 28-29 August the Mission visited Zamalka and Ein Tarma of East Ghouta for a total time of five and a half hours. In spite of the imposed time constraints, and repeated threats of harm, including an actual attack on the convoy by an unidentified sniper on 26 August, the Mission was nonetheless able to gather a considerable amount of information and to collect the necessary amount of samples.

19. The Mission was also able to collect primary statements from more than fifty exposed survivors including patients, health workers and first-responders. Based on these statements and the information gathered from various reports, the surface-to-surface rockets impacted in the early morning hours of 21 August.

20. Survivors reported an attack with shelling, followed by the onset of a common range of symptoms, including shortness of breath, disorientation, rhinorrhea (runny nose), eye irritation, blurred vision, nausea, vomiting, general weakness, and eventual loss of consciousness. Those who went to assist other community members described seeing a large number of individuals lying on the ground, many of whom were deceased or unconscious. These individuals reported observing labored breathing and excessive salivation among a large proportion of the survivors. Several of these “first responders” also became ill, with one describing the onset of blurred vision, generalized weakness, shaking, a sensation of impending doom, followed by fainting.

21. Nine nurses and seven treating physicians were interviewed by the Mission. Most were at their respective homes at the time of incident, with several responding immediately to assist exposed individuals at the site of the incident. Those clinicians who responded in the field described seeing a large number of ill or deceased persons lying in the streets without external signs of injury. Most survivors were described as being unconscious, with many demonstrating laboured breathing. The responders attempted to assist the survivors through the provision of first aid, decontamination with water where possible, and transfer to the nearest hospital by whatever means possible – usually by private car.

**Weather conditions in Damascus on 21 August:**

22. Weather information from Damascus on the morning of 21 August shows a falling temperature between 0200h and 0500h in the morning (Worldweatheronline.com). This means that the air is not moving from the ground upwards, but rather the opposite. Chemical weapons use in such meteorological conditions maximizes their potential impact as the heavy gas can stay close to the ground and penetrate into lower levels of buildings and constructions where many people were seeking shelter.

**Information about munitions:**

23. Information gathered about the delivery systems used was essential for the investigation. Indeed, several surface to surface rockets capable of delivering significant chemical payloads were identified and recorded at the investigated sites. These were carefully measured, photographed and sampled. Samples later confirmed to contain Sarin were recovered from a majority of the rockets or rocket fragments. For more detailed information and assessments see Appendix 5.

**Information concerning environmental samples:**

24. In total, 30 environmental samples were recovered during the investigation. The samples were taken from impact sites and surrounding areas (See Appendix 6 for further specifications). Samples were subsequently processed and sent for analysis. According to the reports received from the OPCW-designated laboratories, the presence of Sarin, its degradation and/or production by-products were observed in a majority of the samples. In addition, other relevant chemicals, such as stabilizers are indicated and discussed in Appendix 7.

**Information concerning symptoms:**

25. The Mission requested to see 80 survivors who met the criteria established by the Mission. Of the 80 presented the Mission selected 36 who were diagnosed by the medical experts of the Mission. Patients clearly showed symptoms, such as: loss of consciousness (78%), shortness of breath (61%), blurred vision (42%), eye irritation/inflammation (22%), excessive salivation (22%), vomiting (22%), and convulsions/seizures (19%). These symptoms are consistent with an organophosphate intoxication. For a more full discussion of the symptoms see Appendix 4.

### **Information concerning bio-medical samples:**

26. Blood, urine and hair samples were withdrawn from 34 of the 36 patients selected by the Mission who had signs of intoxication. The positive blood and urine specimens provide definitive evidence of exposure to Sarin by almost all of the survivors assessed by the Mission. These results are corroborated by the clinical assessments, which documented symptoms and signs that are consistent with nerve agent exposure, including shortness of breath, eye irritation, excessive salivation, convulsions, confusion/disorientation, and miosis. The findings of the clinical assessments were consistent with information derived from both the interviews with clinicians and the review of medical records, which each reported symptoms and signs consistent with nerve agent exposure. The results of the biomedical samples are discussed in Appendix 4 and displayed in Appendix 7.

### **Conclusions**

27. On the basis of the evidence obtained during our investigation of the Ghouta incident, the conclusion is that, on 21 August 2013, chemical weapons have been used in the ongoing conflict between the parties in the Syrian Arab Republic, also against civilians, including children, on a relatively large scale.

28. In particular, the environmental, chemical and medical samples we have collected provide clear and convincing evidence that surface-to-surface rockets containing the nerve agent Sarin were used in Ein Tarma, Moadamiyah and Zamalka in the Ghouta area of Damascus.

29. The facts supporting this conclusion are:

- Impacted and exploded surface-to-surface rockets, capable to carry a chemical payload, were found to contain Sarin.
- Close to the rocket impact sites, in the area where patients were affected, the environment was found to be contaminated by Sarin.
- Over fifty interviews given by survivors and health care workers provided ample corroboration of the medical and scientific results.
- A number of patients/survivors were clearly diagnosed as intoxicated by an organophosphorous compound.
- Blood and urine samples from the same patients were found positive for Sarin and Sarin signatures.

30. This result leaves us with the deepest concern.



## **Appendices**

Appendix 1: Relevant Legal Instruments

Appendix 2: Methodology Used in the Investigation and Securing Evidences

Appendix 3: Planning and Preparing for Entries into the Areas to be Investigated

Appendix 4: Bio-medical Fact Finding Activities

Appendix 5: Munitions Recovered in Moadamiyah and Zamalka/Ein Tarma

Appendix 6: Environmental Samples Collected in Moadamiyah and  
Zamalka/Ein Tarma

Appendix 7: Results from Laboratory Analysis

## Appendix 1

### Relevant Legal Instruments and Guidance

1. 1925 Geneva Protocol for the Prohibition of the Use in war of Asphyxiating, Poisonous or Other Gases, and of Bacteriological Methods of Warfare
2. Guidelines and Procedures for the Timely and Efficient Investigation of Reports of the Possible Use of Chemical and Bacteriological (Biological) or Toxin Weapons (A/44/561)
3. Agreement concerning the Relationship between the United Nations and the Organization for the Prohibition of Chemical Weapons and the Supplementary Arrangement concerning the Implementation of Article II(2)(C) of the UN-OPCW Relationship Agreement
4. Agreement between the United Nations and the World Health Organization adopted by the World Health Assembly and the UN-WHO Memorandum of Understanding concerning WHO Support to the Secretary-General Mechanism for Investigation of the Alleged Use of Chemical, Biological or Toxin Weapons

## Appendix 2

### Methodology Used in the Investigation and Securing Evidences

The Mission was guided by the United Nations Guidelines and Procedures for the timely and efficient investigation of reports of the possible use of chemical and bacteriological (biological) or toxin weapons (A/44/561), as well as the modern scientific standards applied by OPCW and WHO for their respective specializations.

#### Standard Operating Procedures (SOPs) and Working Instructions (WI) used in the present mission:

1	QDOC/INS/SOP/IAU01:	Standard Operating Procedure for Evidence Collection, Documentation, Chain-of-Custody and Preservation during an Investigation of Alleged use of Chemical Weapons
2	QDOC/INS/SOP/GG011	Standard Operating Procedure for Managing Inspection Laptops and Other Confidentiality Support Materials
3	QDOC/LAB/SOP/OSA2:	Standard Operating Procedure Off-Site Analysis of Authentic Samples
4	QDOC/LAB/WI/CS01:	Handling of Authentic Samples from Inspection Sites and Packing Off-Site Samples at the OPCW Laboratory
5	QDOC/LAB/WI/CS02:	Work Instruction Preparation and Analysis of Control Samples and Corresponding Matrix Blanks at the OPCW Laboratory
6	QDOC/LAB/WI/CS03:	Documentation, Chain of Custody and Confidentiality for Handling Off-Site Samples at the OPCW Laboratory
7	QDOC/LAB/WI/OSA3:	WI The Chain of Custody and Documentation for OPCW Samples On-Site
8	QDOC/LAB/WI/OSA4:	Packing of Off-Site Samples

In addition staff training is regularly performed and documented in the various sub-topics essential for the performance of safe and efficient inspections.

During this particular investigation the Mission collected the following types of evidence:

Bio-medical samples, environmental samples, witness interviews/statements (collected as audio and video) and documents, photos and videos.

The following procedures were also applied during the present investigation:

- All sampling and taking of evidence was performed by qualified and fully trained inspectors.
- All witness statements/interviews were recorded and the recordings documented as evidence.

- All bio-medical samples were collected by local medical professionals under supervision of UN inspectors. Biomedical sample processing was completed by inspectors in the Mission office.
- All solvent impregnated sampling wipes were pre-prepared by the Mission's chemists using analysis-grade solvents and materiel. Such pre-prepared wipes were sealed (with OPCW red frangible seals) in clean vials for use by the field teams. The whole process was recorded on video.
- The collected samples were in the possession of at least one inspector from the time of collection to the transport back to the Mission office.
- At the Mission office, the environmental samples were fully documented, packaged, sealed and packed appropriately for safe transport.
- The integrity of the samples was ensured through tamper-proof seals and/or through their physical possession by an inspector until the hand-over to the OPCW laboratory personnel at the Rotterdam airport on the 31 August 2013. The hand over was documented and photographed and witnessed by Syrian representatives.
- The collection, packaging, sealing and hand-over of the samples were documented through video and photo records.
- All seals and accompanying documentation were confirmed correct/intact prior to the issuance of hand-over/take-over receipts.

## Appendix 3

### Planning and Preparing for Entries into the Areas to be Investigated

An elaborate information exchange took place between UNOJSR and key representatives of the opposition. The information gathered through these exchanges would be used to formulate an action plan for the upcoming visit, which became very critical to the success of the mission.

The specific locations were chosen following the estimation of accessibility to the site, and the value and risk connected to the site. The exchange of information was handled through UN representatives and members of the Mission with representatives of the Syrian Government as well as representatives of the opposition, respectively. It involved recommendations of safe access roads, guarantees of ceasefires, timings among other things.

A leader of the local opposition forces who was deemed prominent in the area to be visited by the Mission, was identified and requested to take 'custody' of the Mission. The point of contact within the opposition was used to ensure the security and movement of the Mission, to facilitate the access to the most critical cases/witnesses to be interviewed and sampled by the Mission and to control patients and crowd in order for the Mission to focus on its main activities.

Furthermore, a prominent local medical doctor was identified. This medical doctor was used to help in preparing for the arrival of the Mission. Logistically, preparations involved making rooms and resources for biomedical sampling available. Concerning the patients, a sufficient number was requested to be presented to the Mission, in order for the Mission to pick a subpopulation for interviews and sampling. Typically a list of screening questions was also circulated to the opposition contacts. This included the queries to help in identification of the most relevant cases.

Also, the arrangements involved the assistance from local doctors and nurses to collect blood, urine and hair samples under the supervision of the Mission. This helped the Mission such that it reduced the time spent for collecting and labeling samples individually and at same time ensured that the critical "Chain of Custody" of samples was maintained.

The Mission also requested individuals who were primary witnesses to events to be available for interviews to gain an insight into the epidemiology of events and identification of munitions impact sites for environmental sampling.

Given the short window available for the site visits and the opaque appreciation of the scene that would greet the Mission once on-site, these efforts of preparation was critical to the success of the mission.

## Appendix 4

### Bio-Medical Fact Finding Activities

Planning for the Bio-medical part of the investigation was an essential investment in the preparations as described in Appendix 3.

#### Special consideration of methods used for collection of Bio-medical data

The main elements of the bio-medical investigation included: analysis of bio-medical samples (blood, urine, hair), clinical assessments, review of medical records, and interviews with a select group of survivors and treating clinicians.

**Selection of Survivors.** Withdrawing and analyzing bio-medical samples (blood, urine, hair) was a prioritized activity within the bio-medical investigation. The selection process used was, therefore, designed to primarily identify survivors who had severe clinical presentations, since these were also expected to have had significant exposure to the chemical agent. The ability to provide a sound history of the event and identify the alleged impact site was also considered in selecting survivors. Therefore, physicians in the two sites, Moadamiyah and Zamalka, were asked to select 30 and 50 survivors respectively.

The selection process was guided by a standardized checklist that aimed to identify individuals who either demonstrated moderate to severe symptoms and signs, or were able to provide a clear and detailed history of the event. These survivors were requested to present to the local hospital on the day of the field visit to meet with the Mission. Physicians at Zamalka were also asked to provide a purposive sample of eight medical records of patients with significant symptoms and signs.

**Screening of Survivors.** At each hospital, survivors were screened to allocate them to groups for either clinical assessments and bio-medical sampling or detailed interviews, based on their reported history and symptoms. In general, those with a history of more severe symptoms and signs were prioritized for screening.

**Clinical Assessments and Biomedical Sampling.** The clinical assessments involved a brief history and limited physical examination, undertaken by two teams of two members each in private rooms, assisted by a local nurse for sample taking. The brief history was taken by an Arabic speaking member of the Mission who collected information about individuals, including: name, parents' name, age, sex, location at time of the incident, address, symptoms experienced, and medical treatment provided.

Survivors were asked a standardized series of questions regarding respiratory, gastrointestinal, neurological, dermatological, and cardiovascular symptoms. The physical examination consisted of a general assessment of the level of neurological orientation, and brief eye and respiratory examinations.

In addition to the blood sample a urine sample was taken from those individuals in whom persistent clinical signs were still observed. Furthermore, among those with especially significant signs, hair samples were also taken.

Each individual was photographed.

**Detailed Interviews with Survivors.** Detailed interviews with survivors were conducted in a private room and recorded on camera and audio-tape. The interviews followed a semi-structured format and aimed to include a narrative of the events and their timeline, and details of actions taken by the individuals following impact. Given time constraints, not all survivors were asked all questions, rather the interview process was adapted to extract the most useful information from each interviewee.

**Brief Epidemiological Interviews.** Brief preliminary epidemiological interviews with survivors were performed. Information from the brief interviews was recorded in the investigator notebooks and photographs of the interviewed individual taken. These interviews, collected additional details regarding impact location, the individual's location at the time of the impact, and whether there were deaths among family members.

**Interviews with Clinicians.** Interviews were also conducted with treating clinicians, who either responded to the event in the field or treated survivors after they arrived in local hospitals. The interviews followed a semi-structured format and were designed to collect information on the symptoms and signs of presenting patients/survivors; treatment provided and subsequent clinical progress; and the presence or not of secondary contamination. Time constraints resulted in the truncation of several of the interviews and it was therefore not possible to ask all interviewees the full range of questions.

**Review of Medical Records.** A purposive sample of eight medical records of survivors presenting to Zamalka Hospital was selected by the head physician. Records of survivors who demonstrated moderate to severe symptoms and signs were prioritized. Photocopies of these records were reviewed and analyzed by an Arabic-speaking physician member of the Mission.

**Ethical Issues and Considerations.** In conducting the clinical assessments and detailed interviews, full consideration was given to the privacy and protection of participants. All information was kept confidential and the identity of survivors protected at all times. An identity number was assigned to each participant and this number was used for the processing of data. The master list with the names of the witnesses is kept secure with the leader of the Mission. Throughout the investigation, the Mission made all efforts to respect religious values and norms, national customs, and the personal pressures and traumas associated with exposure to conflict.

## Results

**Clinical Assessments.** A total of 36 individuals underwent clinical assessments, including both brief history and physical examination. Of these, 44 % were assessed at Moadamiyah and 56% of at Zamalka (Table 1).

The average age was 30 years, with a range of 7 to 68 years. Sixty-nine (69) percent were male. Of the survivors, 30 (83%) reported that they developed symptoms following an alleged military strike on or near their homes: the remaining six (17%) reported that they became ill after they went to assist others who had been affected by the alleged strikes.

**Table 1:** Numbers of survivors undergoing clinical assessments and biomedical testing

Location	Clinical Assessments	Blood samples	Urine samples	Hair samples
Moadamiyah	16	15	4	2
Zamalka	20	19	11	1
<b>Total</b>	<b>36</b>	<b>34</b>	<b>15</b>	<b>3</b>

The main symptoms reported by survivors included loss of consciousness (78%), shortness of breath (61%), blurred vision (42%), eye irritation/inflammation (22%), excessive salivation (22%), vomiting (22%), and convulsions/seizures (19%). The full range of symptoms and signs are presented in the chart below.

**Chart:** Symptoms and signs of survivors (N=36)

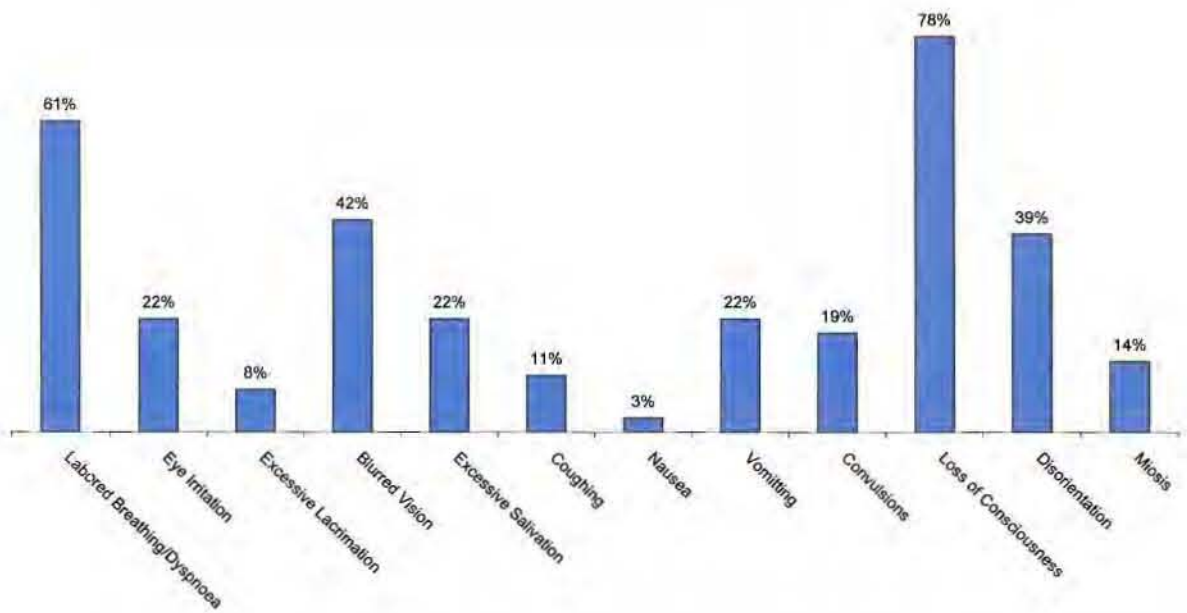

Physical examination demonstrated that 39% of survivors were confused or disoriented at the time of the assessment and that 14% had miosis (constriction of pupils) (Figures 2 and 3).





**Figure 2:** Miosis (constriction of pupils)

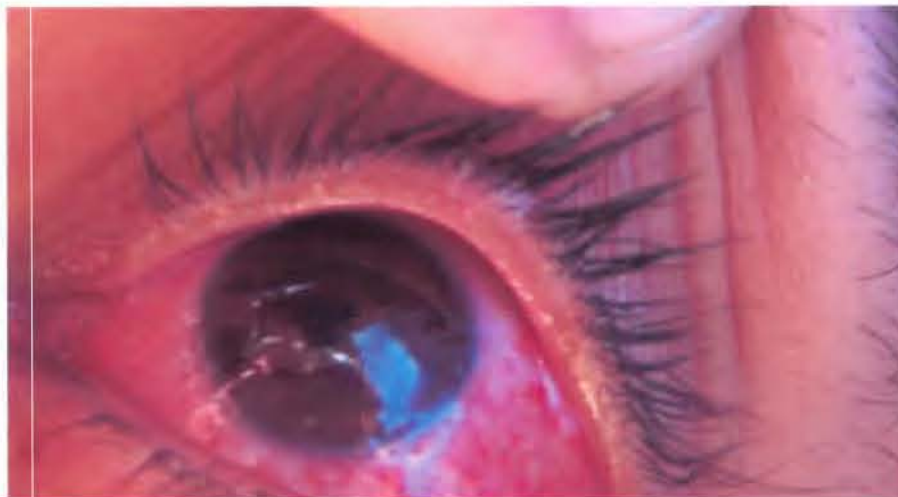

**Figure 3:** Inflammation of the eye

In spite of the fact that the clinical assessments in Moadamiyah occurred five days following the alleged incident and the assessments in Zamalka occurred seven days following the alleged incident, these signs were persistent. Moreover, according to treating clinicians almost all patients received atropine, although it was not possible to determine which of the survivors who were assessed by the Mission received atropine, nor what dose was administered. There were no signs of physical injury among the survivors examined.

**Bio-medical Samples.** Blood samples were available for laboratory analysis from 34 of 36 survivors, two refusing to have blood withdrawn (Table 1). Fifteen of the survivors who had more severe symptoms or signs during the clinical assessment also had urine samples taken, with three of these also having hair samples taken. Specimens were analyzed at laboratories designated by the OPCW.

Of the 34 blood samples tested, 91% tested positive for Sarin exposure in Laboratory 4 and 85% tested positive in Laboratory 3 (Table 2). There was discordance of results for two samples only. A slightly higher percentage of samples from Moadamiyah were positive (Laboratory 4 100% and Laboratory 3 93%) than from Zamalka (Laboratory 4 91% and Laboratory 3 85%).

At the time of writing, results for the urine samples were only available from Laboratory 4. Overall, 93% of urine samples were positive, with 100% positive from Moadamiyah and 91% positive from Zamalka. None of the three hair samples tested positive for Sarin exposure.

**Table 2: Results of biomedical testing**

	Laboratory 3				Laboratory 4			
	Plasma		Urine		Plasma		Urine	
	Number	%	Number	%	Number	%	Number	%
<b>Moadamiyah</b>								
Positive	14	93%	N/A	N/A	15	100%	4	100%
Negative	1	7%	N/A	N/A	0	0%	0	0%
Total	15	100%			15	100%	4	100%
<b>Zamalka</b>								
Positive	15	79%	N/A	N/A	16	84%	10	91%
Negative	4	21%	N/A	N/A	3	16%	1	9%
Total	19	100%			19	100%	11	100%
<b>Combined totals</b>								
Positive	29	85%	N/A	N/A	31	91%	14	93%
Negative	5	15%	N/A	N/A	3	9%	1	7%
Total	34	100%			34	100%	15	100%

NA = not available

**Results of Plasma testing**

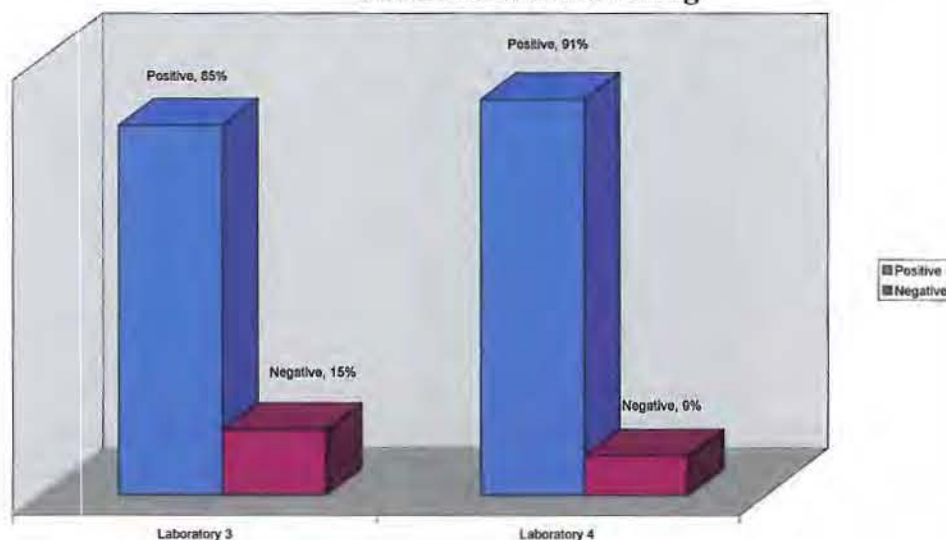

### Interviews with Survivors.

Detailed interviews were conducted with 28 survivors. Clinical information was obtained from 17 individuals and environmental/impact site information was obtained from 11 (Table 3). Brief epidemiological interviews were conducted with 25 survivors.

**Table 3:** Details of survivors undergoing detailed interviews.

Detailed Interviews (N=28)			
Location	Interview Topic		Daily Total
	Clinical	Environmental	
Moadamiyah	3	1	4
Zamalka	14	10	24
<b>Total</b>	<b>17</b>	<b>11</b>	<b>28</b>

Final analysis of the detailed interviews was not available at the time of writing. But several key details were consistently obtained from the interview records and video/audiotapes. Survivors reported a military attack with shelling, followed by the onset of a common range of symptoms, including shortness of breath, disorientation, rhinorrhea (runny nose), eye irritation, blurred vision, nausea, vomiting, general weakness, and eventual loss of consciousness. Those who went to assist other community members described seeing a large number of individuals lying on the ground, many of whom were deceased or unconscious. These individuals reported observing labored breathing and excessive salivation among a large proportion of the survivors. Several of these “first responders” also became ill, with one describing the onset of blurred vision, generalized weakness, shaking, a sensation of impending doom, followed by fainting.

Many survivors reported deaths among family members. Two brothers from Zamalka reported that of the 40 family members who lived in the same building, they were the only survivors. Of the 25 survivors participating in the brief epidemiological interviews, 16 (70%) lost at least two family members.

Survivors were transported to medical facilities by a variety of means, often being referred between facilities. Of those who were able to describe the treatment provided, most reported receiving atropine, hydrocortisone/cortisone, and oxygen.

**Interviews with Clinicians.** Nine nurses and seven treating physicians were interviewed by the Mission. Most were at their respective homes at the time of incident, with several responding immediately to assist exposed individuals at the site of the incident. Those clinicians who responded in the field described seeing a large number of ill or deceased persons lying in the streets without external signs of injury. Most survivors were described as being unconscious, with many demonstrating laboured breathing. The responders attempted to assist the survivors through the provision of first aid, decontamination with water where possible, and transfer to the nearest hospital by whatever means possible – usually by private car.

The most common signs described by the clinicians among survivors brought to the hospital were laboured breathing, excessive salivation, and loss of consciousness. Symptomatic patients were treated with atropine injections, hydrocortisone injections, and oxygen therapy – dosages were not available. A range of severity was reported by the clinicians – a proportion

of survivors were treated on an outpatient basis: others required admission, with some still inpatients at the time of the field visit: others were transferred to other health facilities for a higher level of care.

**Medical records.** The eight medical records from Zamalka Hospital were reviewed for demographics, clinical presentation, and treatment. All cases were male, with an average age of 27 years (range 18 – 50 years). The most common symptoms and signs documented included shortness of breath / labored breathing (87.5 %), blurred vision (75%), vomiting (62.5%), miosis (50%), and headache (50%). All patients received atropine treatment, although dosages were not consistently recorded. The other main treatments reported included hydrocortisone (87.5%) and oxygen (37.5%). Again, dosages were not consistently recorded.

**Conclusion.** The positive blood and urine specimens provide definitive evidence of exposure to Sarin by a large proportion of the survivors assessed by the investigation Mission. These results are corroborated by the clinical assessments, which documented symptoms and signs that are consistent with nerve agent exposure, including shortness of breath, eye irritation, excessive salivation, convulsions, confusion/disorientation, and miosis. The findings of the clinical assessments were consistent with information derived from both the interviews with clinicians and the review of medical records, which each reported symptoms and signs consistent with nerve agent exposure.

## Appendix 5

### Munitions recovered in Moadamiyah and Zamalka/Ein Tarma

#### **Observations and assessments from Moadamiyah findings:**

The team began the investigation of an alleged impact site which was initially located in the backyard terrace of an apartment building. The information given to the Mission was that, in and around this building, persons either died or were affected by a toxic material after coming under attack via barrage on the 21 August 2013. The members of the Mission discovered, at this location, a small crater/impact point in the stone tiles which formed the floor of the terrace. Stone and earth debris were scattered outside of the crater as well as small metal fragments were visible in the locality. Of primary interest was the intact rocket motor found coincident to the impact crater. This rocket motor was noted to have stone and earth debris impacted in the front section of the motor identical to that found in the crater. There was no indication of damage around the crater area having been caused by blast or explosives. This implies that the warhead was not present upon final impact. Noting the location of the impact crater and other damage to the upper parts of existing fence/trellis work, the inspectors followed the trajectory of the rocket and determined that it initially impacted the corner of the second floor of an adjacent apartment building to the east, with either the warhead functioning or shearing off from the body at that point and the motor section having sufficient kinetic energy to continue along its path to its terminal impact location.

Following an overall reconnaissance of the area, the members of the Mission took samples, made detector readings (no detection indications on the LCD 3.3) and took measurements of the area and the discovered munition. The scene was photographed and video was recorded throughout the entire activity.

Upon further discussion with alleged witnesses, the team moved to the adjacent apartment building where the initial debris from the first impact/functioning of the rocket was found. The Mission was told that the inhabitants of this location were also injured or killed by a 'gas'. This location was also surveyed and no intact identifiable munitions fragments were located. Masonry debris and smaller metal fragments were noted and relevant samples were taken both inside the apartment where victims were alleged to have been as well as from the debris field.

#### **The ordnance identified had the following characteristics:**

Color: light gray painting

Markings:

1. Black numbers on the outside: 97-179
2. Engravings on the bottom ring of the engine: Г И III 4 25 - 6 7 - 179 K

Dimensions:

Length ~ 630 mm

Width ~ 140 mm

The engine had 10 jet nozzles ordered in a circle at the end of the rocket with a metal electrical contact plate in the middle.

#### **Limitations:**

The time necessary to conduct a detailed survey of both locations as well as take samples was very limited. The sites have been well travelled by other individuals both before and during the investigation. Fragments and other possible evidence have clearly been handled/moved prior to the arrival of the investigation team.

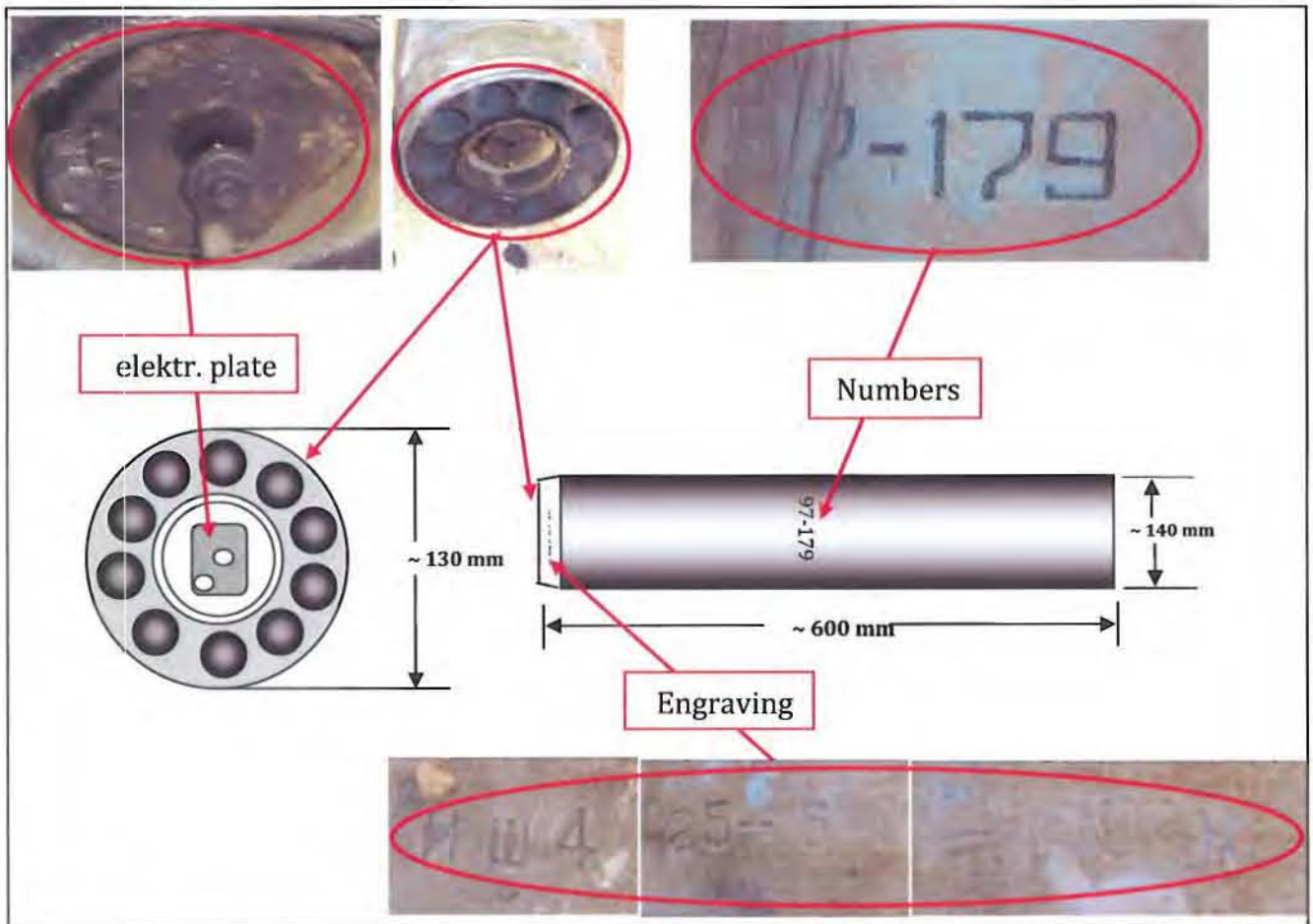

**Observations and assessments from the Zamalka/Ein Tarma findings:**

One team moved to the location of an alleged munition impact located on the roof of a five story building, the second team moved to another alleged impact point located in a nearby open field.

The two teams worked in parallel and identified the same type of munition at both sites. The munition had features noted as being consistent with that of an unguided rocket.

All measurements and dimensions are the result of both team findings. Some rocket parts were deformed on impact and the measurements should be considered as best estimates.

Based on the orientation of the impact craters, orientation of certain surviving munition components and other damage in the areas, the rockets are believed to have arrived from the northwest.

Below is a drawing of the found ordnance, the body has been divided into two parts.

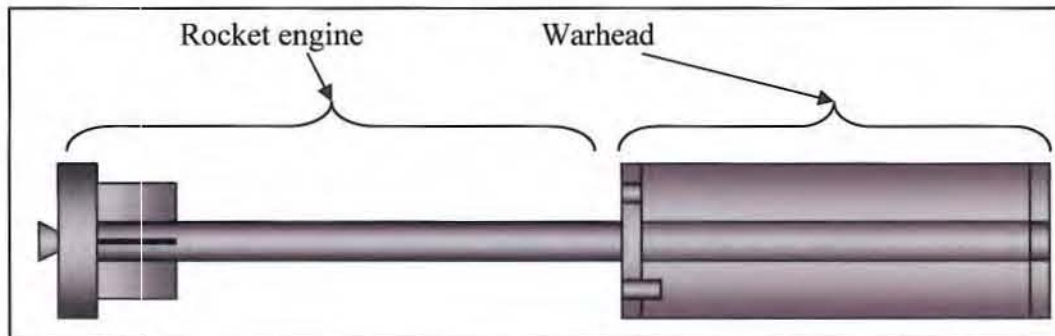

**The rocket engine:**

Six stabilizer fins are equally arranged in a circle and stabilized with a metal ring. One rocket had a red number 153 sprayed in the middle of the engine tube.

The engine tube is attached to the warhead with 12 bolts.

- Total length of the engine: ~134 cm (exit nozzle not included)
- Length of rocket motor fins: ~16.5 cm
- Width of stabilizing ring: ~5.5 cm
- Length of motor exit nozzle: ~4.5 cm
- Length of motor engine shaft: ~112 cm
- Ø of engine shaft: ~12 cm
- Ø of stabilizer ring: ~31 cm

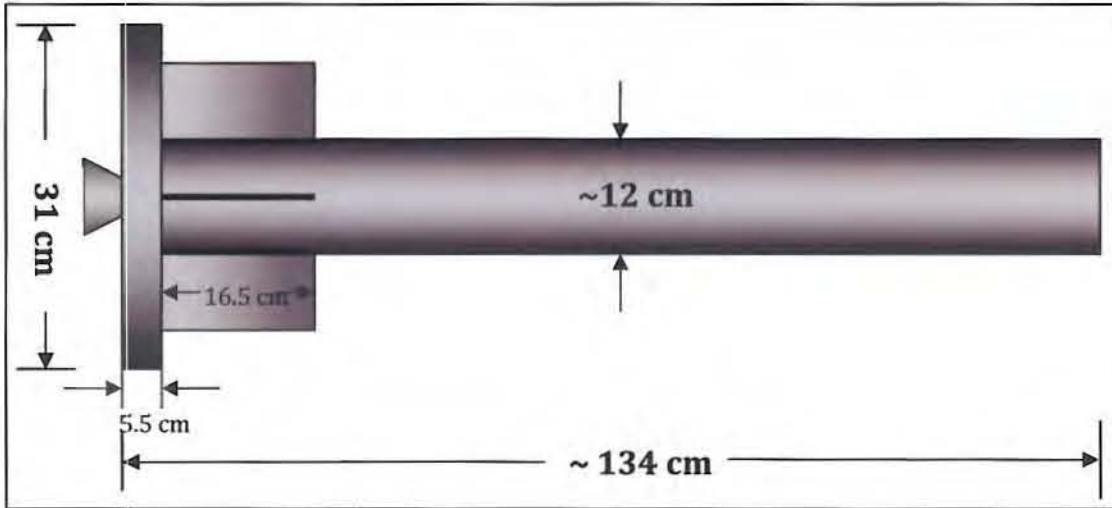

**The warhead** consists of:

- Front metal plate with a fuse thread in the center
  - Ø outside: ~ 36 cm
  - Ø fuse thread: ~ 9 cm

- Six threaded attachment holes are equally arranged in a circle near the outer ring
- Body / outer container consisting of metal plate
  - Thickness ~ 5 mm
- Metal base plate with filling plug, tube and attachment ring with 12 bolts.
  - $\varnothing$  outside: ~ 36 cm
  - $\varnothing$  square bolt ~ 7 cm
  - $\varnothing$  integrated tube on the base plate ~ 3 cm
  - Length of the tube ~ 10 cm
- Central tube of the warhead
  - Length of tube: ~ 70 cm
  - $\varnothing$  of the tube: ~ 12 cm

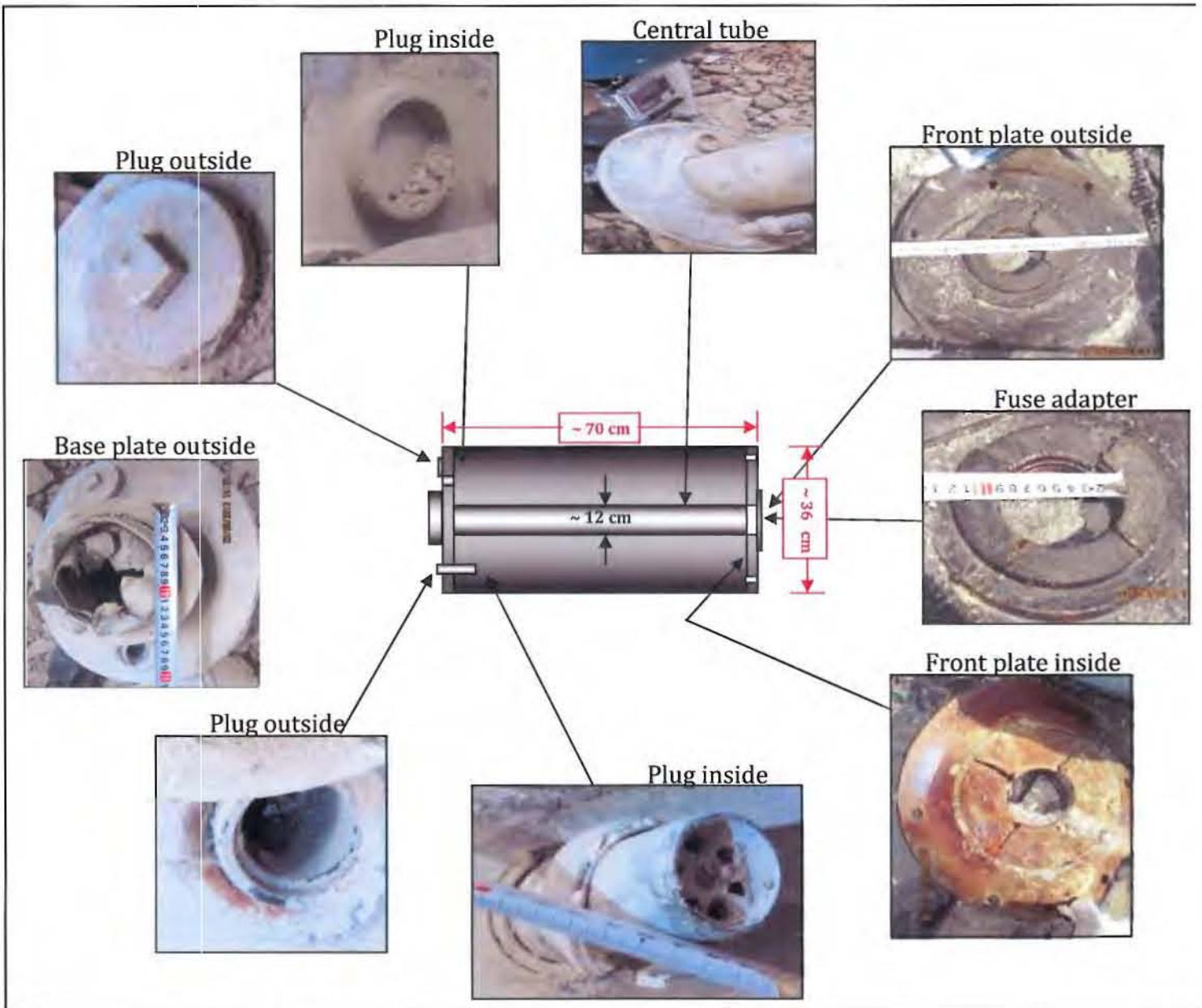

**Liquid capacity of the warhead:**

The approx. capacity of liquid in the warhead is according to the measurements between  $56 \pm 6$  liters. This calculation is exclusive to the thickness of the container walls and any other unknown components possibly contained in the warhead.



**Remarks:**



1. The rocket found by the sub-team on the roof penetrated a cinderblock wall and a rebar containing concrete floor before coming to rest in a room below. The suspected front plate of the warhead and other parts suspected of being the warhead casing were found in front of the first wall and not in the lower room. Additionally, they did not exhibit signs of significant deformation or damage due to kinetic impact. Based on the found evidence; there is an indication that the rocket warhead appeared to function prior to impacting on the roof, releasing its contents and depositing the discovered fragments before travelling through the structure to its terminal location. Apart from the rocket motor and the front central tube with the base plate, no other munition fragments were found in the lower room.

2. The front plate showed 6 symmetric threaded holes around the outline. It's unclear what part(s) are attached through these holes.

**Limitations:**

As with other sites, the locations have been well traveled by other individuals prior to the arrival of the Mission. Time spent on the sites was well used but limited. During the time spent at these locations, individuals arrived carrying other suspected munitions indicating that such potential evidence is being moved and possibly manipulated.

**Considerations on the likely trajectory of the rockets**

Of the five impact sites investigated by the mission, three do not present physical characteristics allowing a successful study of the trajectories followed by the rockets involved, due to the configuration of the impact places. However, Impact site number 1 (Moadamiyah) and Impact site number 4 (Ein Tarma) provide sufficient evidence to determine, with a sufficient degree of accuracy, the likely trajectory of the projectiles.

### **Impact Site Number 1**

The munition linked to this impact site, by observed and measured characteristics, indicatively matches one of the variants of the M14 artillery rocket, with either an original or an improvised warhead (not observed at the impact site). In the final stage of this trajectory, the projectile hit and pierced through a vegetal screen existing over one of the adjacent walls, before impacting the ground producing a shallow crater.

The line linking the crater and the piercing in the vegetal screen can be conclusively established and has a bearing of 35 degrees. This line represents an inverse azimuth to the original trajectory of the rocket, that is to say, the original trajectory of the projectile, as it hit the ground, had an azimuth of 215 degrees.

Impact Site Number 2 is located 65 meters away from number 1 and with an azimuth of 214 degrees. Both relative positions are fully congruent with the dispersion pattern commonly associated with rockets launched from a single, multi-barrel, launcher.

### **Impact Site Number 4**

The munition related to this impact site by observed and measured characteristics indicatively matches a 330 mm caliber, artillery rocket. The projectile, in the last stage of its trajectory, hit the surface in an area of earthy, relatively soft, ground where the shaft/engine of the projectile remained dug in, undisturbed until investigated.

The said shaft/engine, presenting no form of lateral bending, pointed precisely in a bearing of 285 degrees that, again, represent a reverse azimuth to the trajectory followed by the rocket during its flight. It can be, thus, concluded that the original azimuth of the rocket trajectory had an azimuth of 105 degrees, in an East/Southeast trajectory.

## Appendix 6

### Environmental Samples Collected in Moadamiyah and Zamalka/Ein Tarma

#### Environmental samples collected in Moadamiyah on 26 August 2013

Sampling at Moadamiyah started at approximately 1600h and ended 1645h.

Below is the list of all environmental samples recovered in Moadamiyah.

	Team	Sampling date	Time	Sampling Description
1	1	26/08/2013	16:16	Soil sample taken from one impact point in one house in Moadamiyah.
2	1	26/08/2013	16:22	Metal fragment taken from the floor of the outside terrace.
3	1	26/08/2013	16:31	Pieces of fabric taken from one bed sheet and one carpet, on the floor, in the living room of an apartment.
4	1	26/08/2013	16:32	A methanol wipe sample taken from the floor of the first room on the ground floor of an apartment.
5	1	26/08/2013	16:33	A dichloromethane wipe sample taken from the floor of the first room on the ground floor of an apartment.
6	1	26/08/2013	16:35	A dichloromethane wipe sample taken from the floor of the second room on the ground floor of an apartment.
7	1	26/08/2013	16:36	A methanol wipe sample taken from the floor, wall edge and wall of the second room on the ground floor of an apartment.
8	1	26/08/2013	16:38	Metal fragment taken from the floor of the outside terrace of an apartment.
9	2	26/08/2013	16:22	Dichloromethane wipe sample taken from a ceramic coated floor in the bedroom where victims were allegedly affected with a toxic chemical.
10	2	26/08/2013	16:25	A methanol wipe sample taken from the sole of a slipper.

11	2	26/08/2013	16:26	A head scarf worn by one victim, allegedly affected with a toxic chemical.
12	2	26/08/2013	16:31	Pieces of fabric taken from one pillow.
13	2	26/08/2013	16:33	Pieces of fabric, taken from the outer and the inner liners of a mattress.

### Environmental samples collected in Zamalka/Ein Tarma on 28 August 2013

The sampling at Zamalka/Ein Tarma started at approximately 1350h and ended at 1436h.

The following environmental samples were recovered:

	Team	Sampling date	Time	Sampling Description
1	1	28/08/2013	14:14	A fragment from the rocket found on the roof of the building.
2	1	28/08/2013	14:26	Rubble taken from the impact point on the roof of the building.
3	1	28/08/2013	14:28	A methanol wipe sample taken from a metal fragment found on the roof of the building.
4	1	28/08/2013	14:30	A metal fragment taken next to the impact point on the roof of the building.
5	1	28/08/2013	14:35	A metal fragment taken next to the impact point on the roof of the building.
6	1	28/08/2013	14:37	A dichloromethane wipe sample taken from a metal piece found on the roof of the building.
7	1	28/08/2013	14:40	A wipe with dichloromethane sample taken from inside the central tube of the rocket warhead one floor below the roof.
8	2	28/08/2013	14:34	Soil sample taken near the rocket warhead.
9	2	28/08/2013	14:38	Soil sample taken near the rocket warhead.

10	2	28/08/2013	14:40	A dichloromethane wipe sample taken from rocket body.
11	2	28/08/2013	14:49	A methanol wipe sample taken from a metal fragment.
12	2	28/08/2013	14:51	Metal bolt removed from rocket head combined with paint rust scratched from the surface surrounding the bolt.

Environmental samples collected in Zamalka/Ein Tarma on 29 August 2013

The sampling at Zamalka/Ein Tarma started approximately 1310h and ended 1350h.

The following samples were recovered:

	Team	Sampling date	Time	Description of the sampling
1	1	29/08/2013	13:35	A soil sample taken from the balcony floor.
2	1	29/08/2013	13:36	A dichloromethane wipe sample taken from the inside surface part of the window in the kitchen including window sealant.
3	1	29/08/2013	13:39	Metal part from the suspected ordnance.
4	1	29/08/2013	13:41	Rubber gasket from window.
5	1	29/08/2013	13:46	A soil sample taken from the corner of the balcony.

## Appendix 7

### Results from Laboratory Analysis

#### 7.1 Environmental sample results

S N	Sampling date	Sample code	Result laboratory 1			Result laboratory 2			Description of the sampling
			CW Agent	Degradation or and by- Products	Other interesting chemical	CW Agent	Degradati on Products	Other interesting chemical	
1	26/08/2013	01SLS	None	IPMPA DIMP		None	DIMP		Soil sample
2	26/08/2013	07SDS	DCM ex	None	None	None	DIMP		Metal fragment taken from the floor of the outside terrace.
			MeOH ex	None	None	None	IPMPA MPA		
3	26/08/2013	08SDS	DCM ex	None	None	None	DIMP		Metal Fragment
			MeOH ex	None	None	None	DIMP IPMPA MPA	Hexafluoro phosphate	
4	26/08/2013	02SDS	None	None		None	None		Pieces of fabric taken from one bead sheet and one carpet, on the floor, in the living room of an apartment.

S N	Sampling date	Sample code	Result laboratory 1			Result laboratory 2			Description of the sampling
			CW Agent	Degradation or and by- Products	Other interesting chemical	CW Agent	Degradati on Products	Other interesting chemical	
5	26/08/2013	03WPS	None	None		None	None	Hexamethylenetetramine	Dichloromethane wipe sample from apartment floor.
6	26/08/2013	04WPS	None	None		None	None	Hexamethylenetetramine	Methanol wipe sample from apartment floor.
7	26/08/2013	05WPS	None	None		None	None	Hexamethylenetetramine	Dichloromethane wipe sample from apartment floor.
8	26/08/2013	06WPS	None	None		None	None		A methanol wipe sample taken from the floor, the edge of the wall and the wall of the second room of an apartment.
9	26/08/2013	09WPS	None	None		None	DIMP	Hexamethylenetetramine	A wipe with dichloromethane sample taken from a ceramic coated floor in the bedroom where victims were allegedly affected with atoxic chemical

S N	Sampling date	Sample code	Result laboratory 1			Result laboratory 2			Description of the sampling
			CW Agent	Degradation of and by- Products	Other interesting chemical	CW Agent	Degradation Products	Other interesting chemical	
10	26/08/2013	10WPS	None	None		None	None		A methanol wipe sample taken from the sole of a slipper.
11	26/08/2013	12SDS	None	None		None	None		Pieces of fabric taken from one pillow.
12	26/08/2013	11SDS	None	IPMPA		None	None		A head scarf of one victim, allegedly affected with a toxic chemical.
13	26/08/2013	13SDS	None	None		None	None		Pieces of fabric, taken from the outer and the inner liners of a mattress.



S N	Sampling date	Sample code		Result laboratory 1			Result laboratory 2			Description of the sampling
				CW Agent	Degradation or and by- Products	Other interesting chemical	CW Agent	Degradati on Products	Other interesting chemical	
14	28/08/2013	0 1 S D S	DCM ex	None	IPMPA DIMP		GB	DIMP	Ethyl isopropyl methylphosphonate Hexamethylentetramine	A metal fragment found on the roof of the building.
			MeOH ex	None	IPMPA DIMP		None	IPMPA DIMP	Hexafluoro phosphate	
15	28/08/2013	06WPS		None	IPMPA DIMP		GB	DIMP	Hexamethylentetramine	A methanol wipe sample taken from a metal fragment found on the roof of the building.
16	28/08/2013	03WPS		None	IPMPA DIMP		GB	DIMP	Hexamethylentetramine Isopropyl methyl methylphosphonate	A dichloromethane wipe sample taken from a metal fragment found on the roof of the building.
17	28/08/2013	02SLS		None	IPMPA DIMP		GB	DIMP	Ethyl isopropyl methylphosphonate Isopropyl methyl methylphosphonate Isopropyl propyl methylphosphonate Trinitrotoluene Hexamethylentetramine	Rubble taken from the impact point on the roof of the building.

S N	Sampling date	Sample code		Result laboratory 1			Result laboratory 2			Description of the sampling
				CW Agent	Degradation or and by-Products	Other interesting chemical	CW Agent	Degradation Products	Other interesting chemical	
18	28/08/2013	07WPS		None	IPMPA DIMP		GB	DIMP	Hexamethylentetramine	A wipe with dichloromethane sample taken from inside the central tube of the rocket warhead one floor below the roof.
19	28/08/2013	04SDS	DCM ex	GB	DIMP		GB	DIMP	Ethyl isopropyl methylphosphonate Hexamethylentetramine	A metal fragment taken next to the impact point on the roof of the building.
			MeOH ex	None	IPMPA DIMP MPFA					
20	28/08/2013	05SDS	DCM ex	GB	DIMP		GB	DIMP	Hexamethylentetramine	A metal fragment taken next to the impact point on the roof of the building.
			MeOH ex	None	IPMPA DIMP MPFA		None	IPMPA MPA DIMP MPFA	Hexafluoro phosphate	
21	28/08/2013	09SLS		None	IPMPA DIMP		GB	DIMP	Ethyl isopropyl methylphosphonate Isopropyl methyl methylphosphonate Hexamethylentetramine	Soil sample taken near the rocket warhead.
22	28/08/2013	10WPS		None	IPMPA DIMP		GB	DIMP	Hexamethylentetramine Diisopropyl dimethylpyrophosphonate Ethyl isopropyl methylphosphonate	A dichloromethane wipe sample taken from the rocket body.

S N	Sampling date	Sample code		Result laboratory 1			Result laboratory 2			Description of the sampling
				CW Agent	Degradation or and by- Products	Other interesting chemical	CW Agent	Degradati on Products	Other interesting chemical	
23	28/08/2013	11WPS		GB	IPMPA DIMP		GB	DIMP MPFA	Isopropyl methyl methylphosphonate Dimethyl fluorophosphate Dimethyl methyl phosphonate Hexamethylenetetramine	A methanol wipe sample taken from a metal fragment.
24	28/08/2013	08SLS		GB	DIMP		GB	DIMP	Ethyl isopropyl methylphosphonate Isopropyl methyl methylphosphonate Hexamethylenetetramine	Soil sample taken near the rocket warhead.
25	28/08/2013	1 2 S D S	DCM ex	GB	DIMP		GB	DIMP	Ethyl isopropyl methylphosphonate Isopropyl propyl methylphosphonate Diisopropyl dimethylpyrophosphonate Hexamethylenetetramine	Metal bolt removed from rocket head combined with paint rust scratched from the surface surrounding the bolt.
			MeOH ex	None	IPMPA DIMP MPFA		None	IPMPA MPA DIMP MPFA	Hexafluoro phosphate	

S N	Sampling date	Sample code		Result laboratory 1			Result laboratory 2			Description of the sampling
				CW Agent	Degradation or and by- Products	Other interesting chemical	CW Agent	Degradati on Products	Other interesting chemical	
26	29/08/2013	0 1 S D S	DCM ex	GB	DIMP		GB	IPMPA DIMP	Ethyl isopropyl methylphosphonate Isopropyl propyl methylphosphonate Diisopropyl dimethylpyrophosphonate Hexamethylenetetramine	Metal part from the suspected ordnance.
			MeOH ex	GB	IPMPA DIMP MPFA		None	IPMPA DIMP MPFA	Hexafluoro phosphate	
27	29/08/2013	03WPS		GB	IPMPA DIMP		GB	DIMP	Diisopropyl dimethylpyrophosphonate Hexamethylenetetramine	A dichloromethane wipe sample taken from the inside surface part of the window in the kitchen including window sealant.
28	29/08/2013	04SDS		GB	DIMP		GB	DIMP	Hexamethylenetetramine	Rubber gasket from window.
29	29/08/2013	02SLS		GB	DIMP		GB	None	Ethyl isopropylmethylphosphonate Isopropyl methyl methylphosphonate Hexamethylenetetramine	A soil sample taken from the balcony floor.
30	29/08/2013	05SLS		GB	DIMP		GB	IPMPA DIMP	Diisopropyl dimethylpyrophosphonate Hexamethylenetetramine	A soil sample taken from the corner of the balcony.
31	25/08/2013	01BLB		None	None	None	None	None		Dichloromethane solvent blank used by the team during the samples collection

S N	Sampling date	Sample code	Result laboratory 1			Result laboratory 2			Description of the sampling
			CW Agent	Degradation or and by- Products	Other interesting chemical	CW Agent	Degradati on Products	Other interesting chemical	
32	25/08/2013	02BLB	None	None	None	None	None	Methanol solvent blank used by the Mission during the samples collection	
33	25/08/2013	01WPB	None	None	None	None	None	Blank wipe with dichloromethane prepared on site	
34	25/08/2013	02WPB	None	None	None	None	None	Blank wipe with dichloromethane prepared on site	
35	25/08/2013	03WPB	None	None	None	None	None	Blank wipe with methanol prepared on site	
36	25/08/2013	04WPB	None	None	None	None	None	Blank wipe with methanol prepared on site	
37		10	None	None	None	None	None	Hair	
38		17	None	None	None	None	None	Hair	
39		36	None	None	None	None	None	Hair	
40		38	None	None	None	None	None	Hair	
41		Soil	None	None	None	None	None	Blank and control sample prepared by the OPCW laboratory	
42		Soil	None	None	Diisopropyl ethylphosphonate*	None	None		Diisopropyl ethylphosphonate*

- Diisopropyl ethylphosphonate was used by the OPCW laboratory as control spike
- GB: Sarin
- IPMPA: Isopropyl methylphosphonate (primary degradation product of GB)
- DIMP: Diisopropyl methylphosphonate (thermal decomposition / synthesis by-product of GB)
- MPFA: Methylphosphonofluoridic acid (thermal decomposition product of GB / hydrolysis product of Methylphosphonic difluoride (DF))

### 7.2 Bio-medical sample results

SN	Surv ID	Laboratory 3		Laboratory 4		Signs and Symptoms											Other information	
		Plasma	Urine	Plasma	Urine	Lab Br /Dysp	Eye Ir	Ex Lac	Bl Vis	Ex Sal	Coug	Naus	Vom	Conv	Loss Con	Disor		Mios
1	001	Pos	NA	Pos	NA	Yes	Yes		Yes				Yes		Yes	Yes		
2	002	Pos	NA	Pos	NA		Yes	Yes					Yes		Yes	Yes	Yes	
3	003	Pos	NRAT	Pos	Pos	Yes	Yes			Yes					Yes	Yes		
4	004	Pos	NA	Pos	NA	Yes			Yes			Yes			Yes	Yes	Yes	
5	005	Neg	NA	Pos	NA													
6	006	Pos	NRAT	Pos	Pos	Yes				Yes					Yes	Yes		
7	007	Pos	NA	Pos	NA								Yes		Yes	Yes		
8	008	Pos	NA	Pos	NA	Yes				Yes					Yes	Yes		
9	020	Pos	NA	Pos	NA	Yes	Yes		Yes					Yes			No	
10	021	Pos	NA	Pos	NA	Yes				Yes			Yes	Yes	Yes			
11	022	Pos	NRAT	Pos	Pos					Yes			Yes	Yes	Yes			
12	023	Pos	NRAT	Pos	Pos	Yes			Yes				Yes		Yes			
13	024	NA	NA	NA	NA				Yes	Yes					Yes			
14	024-1	Pos	NA	Pos	NA	Yes				Yes				Yes	Yes			
15	025	Pos	NA	Pos	NA	Yes			Yes						Yes			
16	026	Pos	NA	Pos	NA	Yes				Yes					Yes			
17	101	Pos	NRAT	Pos	Pos	Yes									Yes			
18	102	Pos	NA	Pos	NA	Yes									Yes			
19	104	Pos	NA	Pos	NA										Yes			
20	105	Neg	NA	Neg	NA	Yes			Yes									
21	106	Pos	NA	Pos	NA	Yes			Yes		Yes				Yes			
22	107	Neg	NA	Neg	NA													
23	108	Pos	NRAT	Pos	Pos	Yes								Yes			Yes	

SN	Surv ID	Laboratory 3		Laboratory 4		Signs and Symptoms											Other information	
		Plasma	Urine	Plasma	Urine	Lab Br /Dysp	Eye Ir	Ex Lac	Bl Vis	Ex Sal	Coug	Naus	Vom	Conv	Loss Con	Disor		Mios
24	109	Neg	NA	Pos	NA	Yes			Yes					Yes				31 year old male living in Zamalka, Al Mazraa. A rocket reportedly landed 20 meters from his residence. He was on the ground floor at the time of the alleged incident. Eight of 9 family members reportedly killed.
25	110	Neg	NRAT	Neg	Neg													
26	111	Pos	NRAT	Pos	Pos	Yes	Yes		Yes			Yes	Yes					17 years old male living in Zamalka, Al Mazraa. He was in the ground floor at the time of the alleged incident. Four of seven family members reportedly lost their lives.
27	120	Pos	NA	Pos	NA	Yes			Yes				Yes		Yes			
28	121	Pos	NRAT	Pos	Pos	Yes			Yes				Yes		Yes			
29	122	NA	NRAT	NA	Pos	Yes	Yes		Yes						Yes			
30	123	Pos	NRAT	Pos	Pos		Yes	Yes	Yes						Yes	Yes	Yes	

SN	Surv ID	Laboratory 3		Laboratory 4		Signs and Symptoms										Other information		
		Plasma	Urine	Plasma	Urine	Lab Br /Dysp	Eye Ir	Ex Lac	Bl Vis	Ex Sal	Coug	Naus	Vom	Conv	Loss Con		Disor	Mios
31	124	Pos	NA	Pos	NA									Yes	Yes			34 years old female living in Zamalka. She was on the first floor at the time of the alleged incident Six of seven family members reportedly lost their lives.
32	125	Pos	NA	Pos	NA		Yes								Yes			8 years old male living in Zamalka. He was on the first floor at the time of the alleged incident. One of seven family members reportedly lost his life.
33	126	Pos	NRAT	Pos	Pos	Yes									Yes	Yes	Yes	38 years old female living in Zamalka. She was in the first floor at the time of the alleged incident. Four of six family members reportedly lost their lives, including her husband and 3 children.



SN	Surv ID	Laboratory 3		Laboratory 4		Signs and Symptoms											Other information		
		Plasma	Urine	Plasma	Urine	Lab Br /Dysp	Eye Ir	Ex Lac	Bl Vis	Ex Sal	Coug	Naus	Vom	Conv	Loss Con	Disor		Mios	
34	127	Pos	NRAT	Pos	Pos											Yes	Yes		30 years old male living in Zamalka, Al Mhareeq. He was on the second floor at the time of the alleged incident. Lost three family members.
35	128	Pos	NRAT	Pos	Pos	Yes	Yes	Yes	Yes		Yes				Yes	Yes			
36	129	Pos	NRAT	Pos	Pos				Yes		Yes				Yes	Yes		49 years old male living in Zamalka, Al Mazraa. He was on the first floor at the time of the alleged incident. Eight of 20 family members reportedly lost their lives. A rocket fell 20 meter away from his residence.	

**Bl Vis:** Blurred Vision  
**Conv:** Convulsions  
**Coug:** Coughing  
**Disor:** Disorientation

**Ex Lac:** Excessive Lacrimation  
**Ex Sal:** Excessive Salivation  
**Eye Ir:** Eye Irritation  
**Lab Br /Dysp:** Labored Breathing/Dyspnoea

**Loss Con:** Loss of Consciousness  
**Mios:** Miosis  
**NA:** Not applicable  
**Naus:** Nausea

**Neg:** Negative  
**NRAT:** No result as today  
**Pos:** Positive  
**Surv ID:** survivor ident.

**SN:** Serial Number  
**Vomi:** Vomiting